

The Second International Conference
on the Conservation of Grotto Sites,
Mogao Grottoes, Dunhuang,
People's Republic of China,
June 28–July 3, 2004

Conservation of Ancient Sites on the Silk Road



Edited by Neville Agnew

Conservation of Ancient Sites on the Silk Road

Conservation of Ancient Sites on the Silk Road

Proceedings of the Second International
Conference on the Conservation of Grotto Sites,
Mogao Grottoes, Dunhuang, People's Republic of
China, June 28–July 3, 2004

Edited by Neville Agnew

THE GETTY CONSERVATION INSTITUTE
LOS ANGELES

Getty Conservation Institute

Timothy P. Whalen, *Director*

Jeanne Marie Teutonico, *Associate Director, Programs*

The Getty Conservation Institute works internationally to advance conservation and to enhance and encourage the preservation and understanding of the visual arts in all of their dimensions—objects, collections, architecture, and sites. The Institute serves the conservation community through scientific research; education and training; field projects; and the dissemination of the results of both its work and the work of others in the field. In all its endeavors, the Institute is committed to addressing unanswered questions and promoting the highest possible standards of conservation practice.

Getty Publications

1200 Getty Center Drive, Suite 500

Los Angeles, California 90049-1682

www.getty.edu

© 2010 J. Paul Getty Trust

Gregory M. Britton, *Publisher*

Tevvy Ball, *Editor*

Sheila Berg, *Copy Editor*

Hespenheide Design, *Designer*

Elizabeth Zozom, *Production Coordinator*

Printed in China at Everbest Printing Company through Four Colour Print Group

FRONT COVER: Portrait of a donor, from cave 85 (corridor, south wall), Mogao Grottoes. Photo by Lorinda Wong

Library of Congress Cataloging-in-Publication Data

Conservation of ancient sites on the Silk Road : proceedings of the second international conference on the conservation of grotto sites, Mogao Grottoes, Dunhuang, People's Republic of China, June 28–July 3, 2004 / edited by Neville Agnew.

p. cm.

ISBN 978-1-60606-013-1 (pbk.)

1. Mural painting and decoration, Chinese—Conservation and restoration—China—Dunhuang Caves—Congresses. 2. Buddhist art—Conservation and restoration—China—Dunhuang Caves—Congresses. 3. Buddhist cave temples—China—Dunhuang Caves—Conservation and restoration—Congresses. 4. Dunhuang Caves (China)—Antiquities—Congresses. 5. Cave paintings—Conservation and restoration—Congresses. 6. Cultural property—Protection—Congresses. I. Agnew, Neville, 1938–

ND2849.T86A53 2010

751.7'30095145—dc22

2009030646

Contents

<i>Tim Whalen</i>	xi	Foreword
<i>Neville Agnew</i>	xii	Preface
<i>Neville Agnew</i>	xiv	Acknowledgments
	xvi	Site Map of the Mogao Grottoes
	xvii	Map of the Silk Road
	xviii	China Dynasty Table
Keynote Presentations		
<i>Fan Jinshi</i>	3	Master Plan for the Conservation and Management of the Mogao Grottoes: Preparation and Achievements
<i>Sharon Sullivan</i>	8	Managing Cultural Heritage Sites: Some Parameters for Success
<i>Zhang Wenbin</i>	19	China's Policy in Relation to International Exchange and Cooperation in Cultural Heritage Conservation in China
<i>Sharon Cather</i>	22	Choices and Judgment: The Professional Conservator at the Interface

PART ONE

International Collaboration

- | | | |
|---|----|--|
| <i>Du Xiaofan, translated by Naomi Hellmann</i> | 35 | UNESCO Support for Cultural Heritage Conservation in China |
| <i>Huang Kezhong</i> | 41 | International Cooperation for the Protection of China's Cultural Heritage |
| <i>Li Zuixiong</i> | 46 | Deterioration and Treatment of Wall Paintings in Grottoes along the Silk Road in China and Related Conservation Efforts |
| <i>Laurent Lévi-Strauss and Roland Lin</i> | 56 | Safeguarding Silk Road Sites in Central Asia |
| <i>Ron van Oers</i> | 62 | Nomination of the Silk Road in China to UNESCO's World Heritage List: Proposals for a Strategic Approach and Reference Framework for Heritage Routes |

PART TWO

Policy and Principles

- | | | |
|-------------------------|----|---|
| <i>Jin Hongkui</i> | 75 | The Content and Theoretical Significance of the <i>Principles for the Conservation of Heritage Sites in China</i> |
| <i>Jean-Louis Luxen</i> | 85 | The <i>Principles for the Conservation of Heritage Sites in China</i> —A Critique |
| <i>Zhang Lizhu</i> | 88 | The Role of Hebei Province in Developing and Implementing the China Principles |

PART THREE

History and Silk Road Studies

- | | | |
|--------------------------|-----|---|
| <i>Susan Whitfield</i> | 95 | A Place of Safekeeping? The Vicissitudes of the Bezeklik Murals |
| <i>John Falconer</i> | 107 | Perspectives on Photography's Contribution to Archaeology in Central Asia |
| <i>Bo Lawergren</i> | 117 | Harps on the Ancient Silk Road |
| <i>Fred H. Martinson</i> | 125 | Stein and Trinkler on the Rawak Vihara: A Mandala Style Moves East |

PART FOUR

Planning and Management

- | | | |
|---|-----|---|
| <i>Ludmila Akmatova and Jumamedel Imankulov</i> | 135 | Conservation and Management of Cultural Heritage Sites on the Silk Road in Kyrgyzstan |
| <i>Li Ping, Sharon Sullivan, Kirsty Altenburg, and Peter Barker</i> | 143 | Visitor Surveys at Mogao: Pioneering the Process, 2002–2004 |
| <i>Kirsty Altenburg, Sharon Sullivan, Li Ping, and Peter Barker</i> | 152 | The Challenge of Managing Visitors at the Mogao Grottoes |
| <i>Martha Demas, Shin Maekawa, Jonathan Bell, and Neville Agnew</i> | 160 | Sustainable Visitation at the Mogao Grottoes: A Methodology for Visitor Carrying Capacity |
| <i>Rickard Mackay</i> | 170 | Social and Environmental Monitoring as a Tool for Managing Visitor Impact at Jenolan Caves, Australia |

PART FIVE

Scientific Research

- | | | |
|--|-----|--|
| <i>Henri Van Damme, Mokhtar Zabat, Jean-Paul Laurent, Patrick Dudoignon, Anne Pantet, David Gélard, and Hugo Houben</i> | 181 | Nature and Distribution of Cohesion Forces in Earthen Building Materials |
| <i>Chikaosa Tanimoto, Chunze Piao, Keigo Koizumi, Shuichi Iwata, Tadashi Masuya, Li Zuixiong, Wang Xudong, and Guo Qinglin</i> | 189 | Geology and Hydrogeology at the Mogao Grottoes, Dunhuang |
| <i>Huang Jizhong</i> | 196 | The Influence of Water on the Stone Carvings of the Yungang Grottoes |
| <i>Catharina Blaensdorf and Ma Tao</i> | 203 | A Chinese-German Cooperative Project for the Preservation of the Cultural Heritage of Shaanxi Province: Conservation of the Polychrome Clay Sculpture and Investigation of Painting Materials in the Great Hall of the Shuilu'an Buddhist Temple |
| <i>Daniela Bathelt and Heinz Langhals</i> | 213 | Two Methods for the Conservation of the Polychromy of the Terracotta Army of Qin Shihuang: Electron Beam Polymerization of Methacrylic Monomers and Consolidation Using Polyethylene Glycol |

<i>Sandra Bucher and Xia Yin</i>	218	The Stone Armor from the Burial Complex of Qin Shihuang in Lintong, China: Methodology for Excavation, Restoration, and Conservation, including the Use of Cyclododecane, a Volatile Temporary Consolidant
<i>Heinz Berke, Armin Portmann, Soraya Bouherour, Ferdinand Wild, Ma Qinglin, and Hans-Georg Wiedemann</i>	225	The Development of Ancient Synthetic Copper-Based Blue and Purple Pigments
<i>Pamela B. Vandiver, Amy Vandiver, Akbar Rakhimov, and Alisher Rakhimov</i>	234	<i>Ishkor</i> Glazes of Uzbekistan
PART SIX		
Examination and Documentation Techniques		
<i>Lu Dongming, Liu Gang, Liu Yang, and Diao Changyu</i>	251	Digital Acquisition, Reconstruction, and Virtual Interpretation of Dunhuang Murals
<i>Harlan Wallach</i>	259	High-Resolution Photography at the Dunhuang Grottoes: Northwestern University's Role in the Mellon International Dunhuang Archive
<i>Pan Yunhe, Fan Jinshi, and Li Zuixiong</i>	262	Dunhuang Grottoes Conservation and Computer Technologies
<i>Haida Liang, David Saunders, John Cupitt, and Christian Lahanier</i>	267	Multispectral Imaging for Easel and Wall Paintings
<i>Rocco Mazzeo, Edith Joseph, Silvia Prati, Ma Tao, Gwénaelle Gautier, and Lucien M. van Valen</i>	275	Scientific Examination of the Traditional Materials and Techniques Used in Yuan Dynasty Wall Paintings
<i>Sanjay Dhar</i>	286	Documentation and Emergency Treatment of Wall Paintings in the Chamba Lakhang (Maitreya Temple): Developing a Methodology to Conserve Mural Paintings in India's Ladakh District
<i>Kathleen M. Garland</i>	297	Surveying Paradise: The Conservation Survey of a Yuan Dynasty Wall Painting on a Clay Base
<i>Zhong Shihang and Huang Kezhong</i>	304	Determining the Internal Condition of the Leshan Buddha Statue

PART SEVEN

Methods and Treatment

- Guo Hong, Han Rubin, Huang Huaiwu,
Lan Riyong, and Xie Riwan* 311 Types of Weathering of the Huashan Rock Paintings
- Ma Qinglin, Chen Genling, Lu Yanling,
and Li Zuixiong* 316 A Study of Support Materials for Mural Paintings
in Humid Environments
- Du Xiaoli, translated by Naomi Hellmann* 324 Study and Conservation of the Dazhao Temple Wall
Painting, Inner Mongolia
- Yang Mangmang and Zhang Yongjian* 331 Pigment Analysis and Environmental Monitoring
of Murals in the Tang Dynasty Huiling Mausoleum
- Sekhar Chandra Set* 336 Indian Wall Paintings: Analysis of Materials
and Techniques
- Tie Fude* 343 Conservation of Mural Paintings Transferred from a
Royal Mausoleum of the Western Han Dynasty at
Shiyuan, Henan Province

PART EIGHT

Consolidation and Stabilization

- Wang Xudong, Li Zuixiong, and Zhang Lu* 351 Condition, Conservation, and Reinforcement of the
Yumen Pass and Hecang Earthen Ruins near Dunhuang
- Wang Wanfu, Wang Tao, Zhang Weimin,
Li Zuixiong, Wang Xudong, Zhang Guobing,
Qiu Fei, and Du Mingyuan* 358 Research and Application Methods for Comprehensive
Control of Wind-Borne Sand at the Mogao Grottoes
- Sun Yihua, Wang Wanfu, and Fu Qingyuan* 365 Restoration and Consolidation of Historic Earthen
Structures: The Upper and Middle Temple Complexes
at the Mogao Grottoes
- He Ling, Jiang Baolian, Zhou Weiqiang,
and Zhen Gang* 370 Consolidation Studies on Sandstone in the
Zhongshan Grotto
- Zhou Shuanglin, Yuan Sixun, Guo Baofa,
and Xia Yin* 380 Nonaqueous Dispersions and Their Antiweathering
Performance for Earthen Buildings, Monuments,
and Archaeological Sites
- Zhang Zhijun* 385 Consolidation Methods for Cracks at the Qin Terracotta
Army Earthen Site
- Wang Hui* 389 The Conservation Program for the Castle Ruins
of the Guge Kingdom in Ali, Tibet

PART NINE

Mogao Grottoes Cave 85 Project

<i>Neville Agnew and Li Zuixiong</i>	397	Objectives of the Cave 85 Project
<i>Wang Jinyu</i>	399	The Significance of Cave 85
<i>Xu Shuqing, Wang Xiaowei, Sun Hongcai, Li Weitang, Francesca Piqué, Lorinda Wong, Leslie Rainer, Li Yunhe, and Zheng Jun</i>	406	Conservation History and Condition Survey of Cave 85, Mogao Grottoes
<i>Neville Agnew, Shin Maekawa, and Shuya Wei</i>	412	Causes and Mechanisms of Deterioration and Damage in Cave 85
<i>Francesca Piqué, Lorinda Wong, and Su Bomin</i>	421	Methodology for the Conservation of the Wall Paintings in Cave 85
<i>Lisa Shekede, Fan Zaixuan, Francesca Piqué, and Lorinda Wong</i>	430	The Role of In Situ Examination in the Technical Investigation of the Cave 85 Paintings
<i>Michael R. Schilling, Joy Mazurek, David Carson, Su Bomin, Fan Yuquan, and Ma Zanfeng</i>	438	Analytical Research in Cave 85
<i>Cecily M. Grzywacz, Jan Wouters, Su Bomin, and Fan Yuquan</i>	450	Asian Organic Colorants: A Collaborative Research Project
<i>James R. Druzik</i>	457	Evaluating the Light Sensitivity of Paints in Selected Wall Paintings at the Mogao Grottoes: Caves 217, 98, and 85
<i>Shin Maekawa, Liu Gang, Xue Ping, Guo Qinglin, and Hou Wenfang</i>	464	Origins of Moisture Affecting the Wall Paintings in Cave 85
<i>Stephen Rickerby, Lisa Shekede, Fan Zaixuan, Tang Wei, Qiao Hai, Yang Jinjian, and Francesca Piqué</i>	471	Development and Testing of the Grouting and Soluble-Salts Reduction Treatments of Cave 85 Wall Paintings
<i>Stephen Rickerby, Lisa Shekede, Fan Zaixuan, Tang Wei, Qiao Hai, and Yang Jinjian</i>	480	Implementation of Grouting and Salts-Reduction Treatments of Cave 85 Wall Paintings
<i>Chen Gangquan, Michael R. Schilling, Li Yanfei, Joy Mazurek, Yu Zhongren, and Lisa Shekede</i>	488	A Rapid Means of Measuring Residual Salt after Grouting and Poulting Wall Paintings
<i>Lorinda Wong, Francesca Piqué, Wang Xiaowei, and Xu Shuqing</i>	494	The Information Management System for the Cave 85 Project
	502	Contributors

Foreword

The Getty Conservation Institute and the Dunhuang Academy, with the endorsement of China's State Administration of Cultural Heritage (SACH), have traveled a long road together, one that began in January 1989 with a formal agreement between the institutions concerned. Since that time, our collaborative activities have included the first Silk Road conference, "Conservation of Ancient Sites on the Silk Road," held in 1993; development of China ICOMOS's "Principles for the Conservation of Heritage Sites in China"; a multiyear wall painting conservation project at the Mogao grottoes; a master's degree course in wall painting conservation, collaboratively organized with the Dunhuang Academy, Lanzhou University, and the Courtauld Institute of Art; and a visitor management and carrying-capacity plan for the fragile cave temples at Mogao.

It therefore gives me great pleasure to write the foreword to this publication of the papers from the second Silk Road conference, held at the Mogao grottoes in 2004. There has been a rich and dynamic interchange of expertise between SACH, the Dunhuang Academy, and the GCI over the two decades of our collaboration. SACH and the Dunhuang Academy have also generously provided resources that have advanced our ability to work in China. Reciprocally, the GCI has hosted visiting staff from both organizations, including participation in some of the GCI's other overseas activities, such as the Queens Valley project in Egypt.

Since the first Silk Road conference was held, an important aspect of our collaborative work has centered on wall painting conservation, with focus on cave 85 at the Mogao

site, a splendid cave temple dating from the late Tang dynasty. This work is summarized in these conference proceedings as a series of papers, intended to establish a methodological yardstick for future research and conservation treatment of the extraordinarily beautiful—yet threatened and delicate—paintings and polychrome sculpture at Mogao and other, similar Silk Road sites.

Lest anyone imagine otherwise, it is not always easy working and collaborating across barriers of language and culture. What is the "glue" that holds together a partnership such as the one that we have enjoyed with our partners in China? Succinctly stated, it is a combination of clearly defined roles and responsibilities, and common objectives. For his work on this volume and his decades-long leadership of the GCI's work in China, I thank Neville Agnew, whose extraordinary professionalism and dedication have been central to our successful partnerships in China. I am most grateful to Fan Jinshi, director of the Dunhuang Academy, and Zhang Bai, deputy director of SACH, for their lasting friendship and commitment to the conservation of China's remarkable heritage. They have been instrumental in making the GCI-China partnership the longest enduring collaboration of the Getty Conservation Institute. Now in the midst of our seventh three-year agreement with SACH at the Dunhuang Academy, we look forward to new challenges, as new opportunities beckon in our future work together.

TIMOTHY P. WHALEN
Director
The Getty Conservation Institute

Preface

Since the first Silk Road conference was held at the Mogao Grottoes in 1993, great changes have taken place—first, new construction and better facilities for visitors and personnel; and second, the professional development of Dunhuang Academy conservation staff. The site has become more accessible with expansion of the local airport, and visitor numbers have increased, at times beyond the capacity of management to cope. Mogao has continued to attract scholars who study the iconography of the wall paintings and statuary and the ancient documents from the famed Library Cave; it has developed expertise in site conservation, management, and presentation; and it has become recognized as a center of excellence in China. This has not been without some cost to the site, however, as greater burden has been placed on staff through demands for the expertise of the Dunhuang Academy to assist less-well-established organizations elsewhere in China in conserving their sites. Perforce, the Dunhuang Academy has had to divert some of its own fully extended personnel to undertake conservation projects elsewhere in China and in other Asian countries as well while serving in an advisory role to a number of national initiatives in conservation. Balancing these requests with the many urgent needs of the Mogao Grottoes and the two other sites, Yulin and the Western Grottoes, under the Dunhuang Academy's management and conservation jurisdiction has been no easy matter. Fortunately, Director Fan Jinshi, whose life has been devoted to the site, has kept an unclouded vision and maintained her priorities for Mogao.

This publication, an outcome of the Second International Conference on the Conservation of Grotto Sites, has appeared more than a decade after the first. While the first conference essentially focused on managerial and technical conservation,

the scope of the second was expanded to include art historical and related topics, though, as can be seen in the table of contents, the emphasis has remained primarily conservation. The purpose of addressing a larger subject matter has been to seek greater inclusivity and to build bridges between conservation and scholarly research on the history of the Mogao Grottoes and the Silk Road in its vast geographic reach. Moreover, because Mogao is a site in the top echelon of significance among China's extensive list of World Heritage Sites and a pivotal one along the ancient Silk Road trade routes, it was thought important in the spirit of exchange between East and West to seek participation from other central Asian countries. This was not entirely successful, but the gesture was made; Kyrgyzstan delegates participated in the event, and Uzbekistan contributors submitted their papers, which are included in this publication.

As stated in the preface to the first Silk Road conference proceedings, the collaboration between the Dunhuang Academy and the Getty Conservation Institute addressed broad site-wide issues of conservation at Mogao. In the present volume the work undertaken since the first conference is presented. These joint efforts reflect, we believe, the far greater synergy that can be generated when partners work together in mutual trust and understanding on problems and issues of common interest.

Looking back, both sides embarked together on ambitious undertakings that include, with the support of the State Administration of Cultural Heritage of China, participation in developing the *Principles for the Conservation of Heritage Sites in China* in partnership with the Australian Heritage Commission; drafting a master plan for the site; research, testing, and conservation of cave 85; and initiation of a

master's degree course in the conservation of wall paintings through a four-way partnership between Lanzhou University (the degree-conferring institution), the Dunhuang Academy, the Courtauld Institute of Art in London, and the Getty Conservation Institute.

Areas of acute need identified in the master plan were also addressed, including a use plan, a visitor management subplan, and a visitor carrying capacity study for the cave temples open to the public. Visitation to the site and increasing visitor numbers represent a dire threat. Unless a cap on visitor numbers, backed by sound research, is implemented as a policy of the Dunhuang Academy, the site will be degraded by overuse and commercial pressures.

Translation between Chinese and English, as always, proved a challenge: both languages, of course, have subtleties and nuances that tax the most expert of translators. Add to these the specialized terminology of conservation, scientific and technical terms, and geographic place-names—to mention but a few—and the problem is compounded.

Many colleagues have striven greatly, as acknowledged elsewhere, to bring this long-delayed publication to fruition. We hope it may prove of value well beyond the confines of the Mogao Grottoes.

NEVILLE AGNEW

Acknowledgments

The Second International Conference on the Conservation of Grotto Sites was a collaborative undertaking of the Getty Conservation Institute and the Dunhuang Academy, with the approval of China's State Administration of Cultural Heritage. The director of the Dunhuang Academy, Fan Jinshi, was an enthusiastic proponent of the event from the first, as was Tong Mingkang, deputy director of the State Administration. Timothy P. Whalen, director of the GCI, likewise endorsed the suggestion of a second conference as a milestone in these institutions' long-standing joint conservation and management planning efforts at the Mogao Grottoes.

It is appropriate to recognize the work of Su Bomin, at the Dunhuang Academy, who undertook arrangements on the Chinese side, and Kathleen Louw, at the GCI, who provided efficient logistical and planning support. Preparation of the manuscript for publication of the proceedings has been a collaborative effort of many colleagues, though an onerous one. Special thanks are due to Elizabeth Maggio, who coedited many of the papers and whose exacting standard has set the tone for the volume. Foremost among the many difficulties has been the challenge of translation from the Chinese. It is not the editor's purpose here to recount the tribulations of attempting to wrestle with the often-inscrutable English in some of the translations that were submitted, or to comment, other than in passing, on manuscripts with incomplete or missing references, but rather to gratefully express appreciation for the unstinting help of colleagues. Po-Ming Lin should be acknowledged first; it was he who spent countless hours on the telephone and via email communicating with authors in an attempt to

clarify points of meaning. His was the patience of Job. Peter Barker likewise was generous with his time and perseverance in attempting to unravel the often highly technical language and terminology. Po-Ming and Peter worked together, consulting with each other and frequently seeking clarification from other Chinese speakers at the Getty Conservation Institute, notably Ye Wa and Zhang Liangren, when their expertise was relevant to the subject matter. Jonathan Bell reviewed certain papers and clarified Buddhist terminology in cases where transliteration from the Chinese resulted in inconsistency with commonly recognized English translation (usually based on the Sanskrit term), Lorinda Wong assisted with a number of papers on wall painting conservation, and Martha Demas repeatedly provided useful counsel on matters of content. In the final throes of editing, Valerie Greathouse and Cameron Trowbridge of the GCI's Information Center reviewed bibliographic citations, completing some, finding others; the institute is fortunate in having staff who, undaunted, tackle such tasks with humor and a sense of challenge. An immense debt of gratitude is due to them.

Getty Publications has been forbearing in the long, often-stalled editorial process, and we are indebted also to Tevvy Ball, Sheila Berg, and Ann Lucke for their patience and their meticulous standards in the handling and copyediting of the manuscript. As always, the designers at Getty Publications have produced an elegant volume appropriate to the art of the site.

Beverly Weisblatt handled the manuscript flow and tracked versions as they were transmitted back and forth between the editors and the authors; her help was essential

throughout the process. Cynthia Godlewski managed efficiently, and with her characteristic tact, all communication and transmission of the final manuscripts to Getty Publications for copyediting, design, and production.

To all of the above we are most grateful.

To those authors who submitted in a timely manner and whose manuscripts were complete and intelligible, we

apologize for the delay in seeing the work in print; we hope, despite the protracted process, that this volume will prove to have been worth the wait.

NEVILLE AGNEW

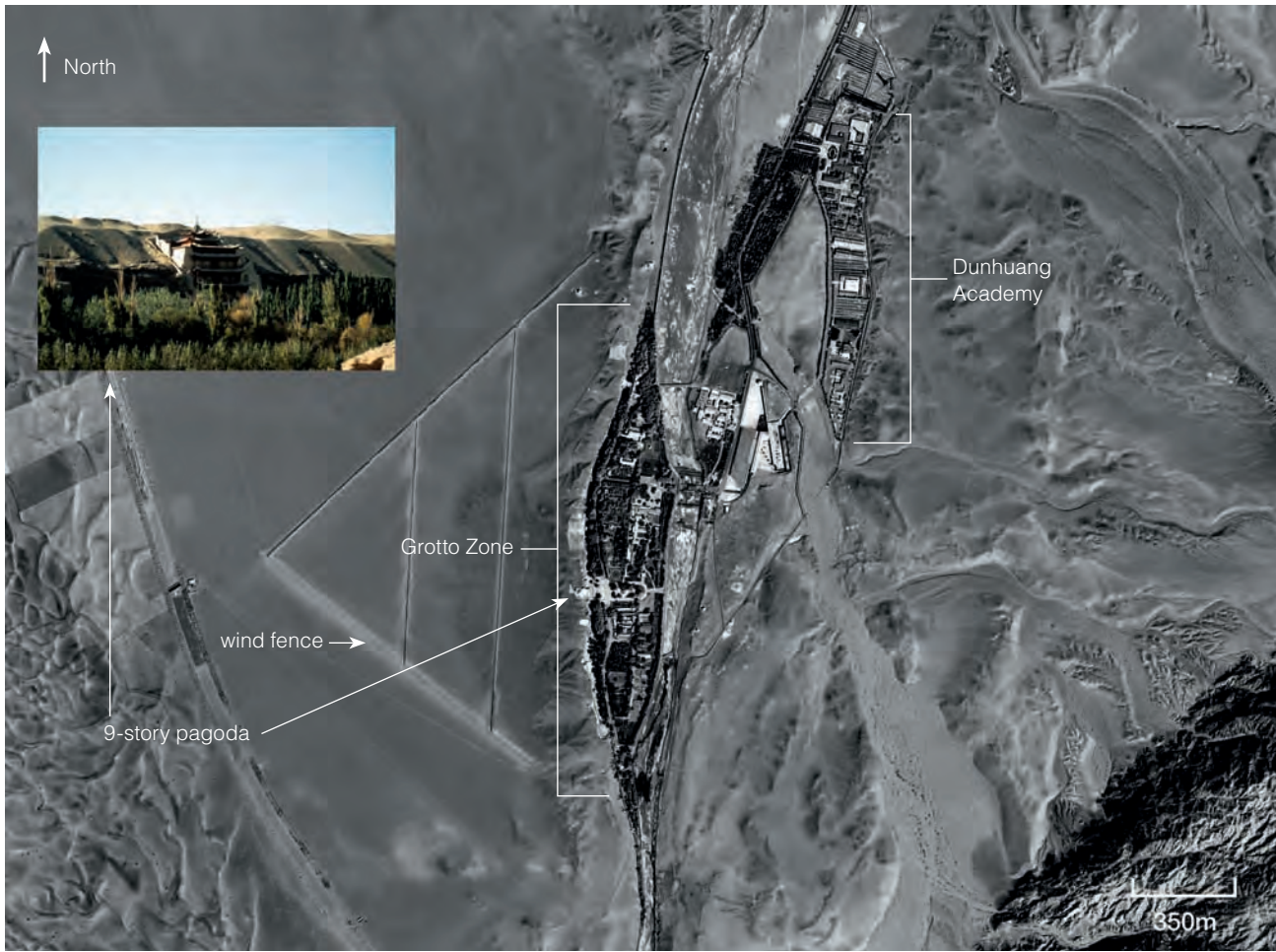

Mogao satellite image.
Satellite image courtesy of Digital Globe.
Inset photo by G. Aldana © J. Paul Getty Trust

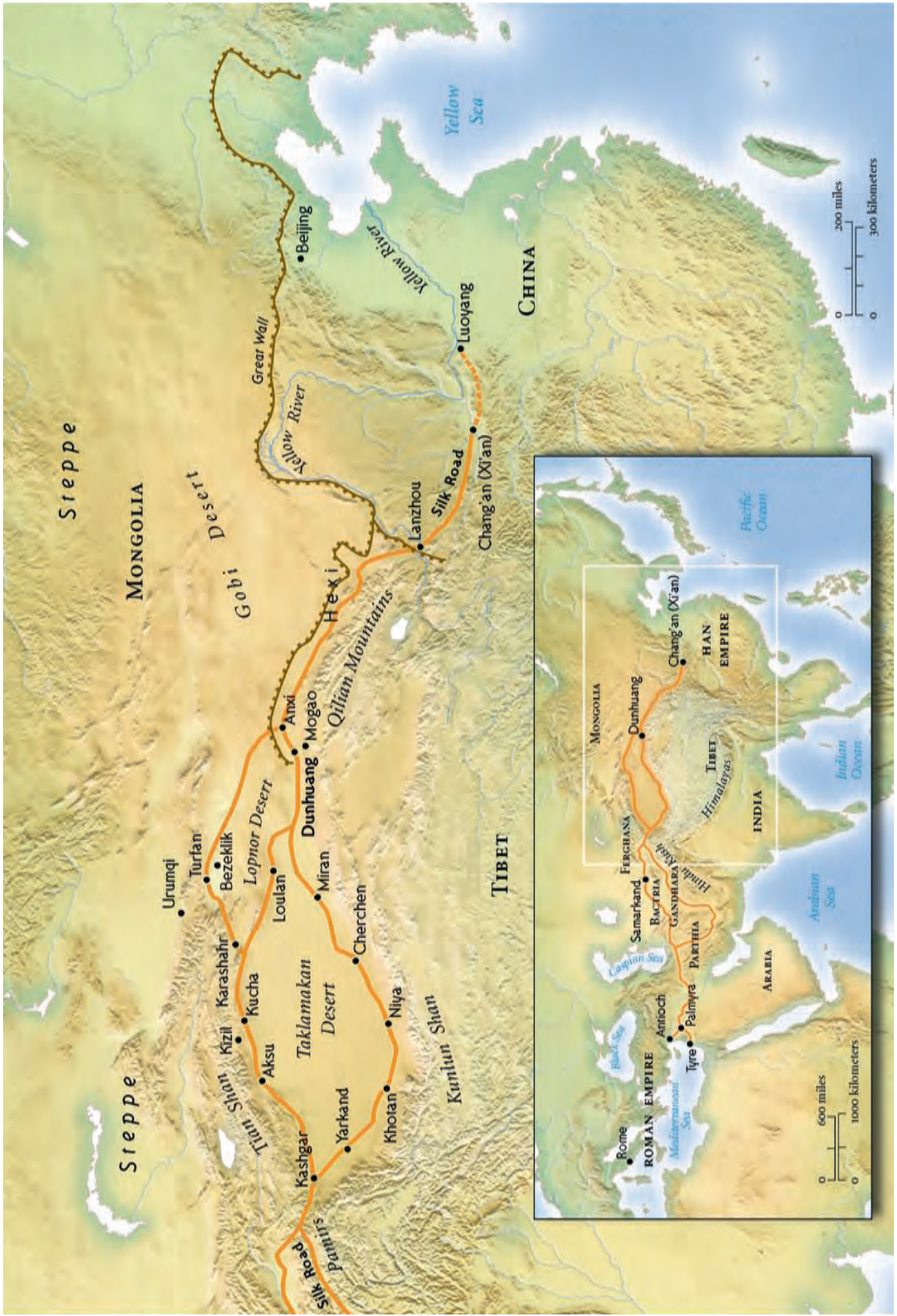

China Dynasty Table

Xia	ca. 21st century–16th century B.C.E.
Shang	ca. 16th century–11th century B.C.E.
Western Zhou	ca. 11th century–770 B.C.E.
Eastern Zhou	
Spring and Autumn Period	770–476 B.C.E.
Warring States Period	475–221 B.C.E.
Qin	221–207 B.C.E.
Western Han	206 B.C.E.–24 C.E.
Eastern Han	25–220
Three Kingdoms	
Wei	220–265
Shu	221–263
Wu	222–280
Western Jin	265–316
Eastern Jin	317–420
Southern and Northern Dynasties	
Sui	589–618
Tang	618–907
Five Dynasties and Ten Kingdoms	
Song	
Northern Song	960–1127
Southern Song	1127–1279
Liao	916–1125
Jin	1115–1234
Yuan	1271–1368
Ming	1368–1644
Qing	1644–1911
Republic of China	1912–1949
People's Republic of China	1949–present

Keynote Presentations



Master Plan for the Conservation and Management of the Mogao Grottoes: Preparation and Achievements

Fan Jinshi

Abstract: *Heritage sites are unique and irreplaceable, which makes their preservation and management a great challenge. A clear master plan is essential to guide conservation and management so that site deterioration can be averted or slowed, cultural value can be determined, and utilization can be effectively coordinated along scientific lines. In this way, heritage sites can continue to serve society. This paper discusses the Master Plan for the Conservation and Management of the Mogao Grottoes, which was drawn up in accordance with the Principles for the Conservation of Heritage Sites in China (known as the China Principles) issued by China ICOMOS with the approval of the State Administration of Cultural Heritage of China. In writing the master plan, the following steps were undertaken: collection and collation of data, assessment of cultural values and significance, evaluation of current status and management, identification of main objectives and the principles for attaining them, and determination of specific project goals and the measures to reach them. The main objectives of the plan for the period 2001–10 are as follows: (1) conservation: measures implemented after research and technical interventions to preserve cultural values and prevent further deterioration, including daily maintenance, addressing safety issues and preventive measures, and visitor management; (2) research: collating, organizing, and studying the artifacts from the grottoes and the Library Cave to enrich the corpus of research on Dunhuang and human knowledge generally; (3) education; and (4) recovery of dispersed artifacts. The master plan lays out a scientific model for conservation and management. In addition, the process, from elaboration to completion, will be one in which conservation professionals and managers will be able to enhance and refine their skills. The continual improvement in preservation*

and management of the Mogao Grottoes will be guaranteed through the comprehensive, scientific, and systematic application of the master plan.

In winter 1997 a committee of cultural heritage experts convened by China's State Administration of Cultural Heritage (SACH), composed of members of the national committee of the International Council on Monuments and Sites (ICOMOS), the Getty Conservation Institute (GCI) in the United States, and the Australian Heritage Commission, initiated the drafting of the *Principles for the Conservation of Heritage Sites in China* (referred to as the China Principles). The China Principles were published in 2000 (in Chinese) by China ICOMOS. This author was among the scholars who participated. The China Principles, which are based on Chinese conservation practice, the framework of relevant laws for protection of cultural heritage, and conservation practices in the West, consist of five chapters with thirty-eight articles covering, among other matters, the conservation process, conservation principles, and conservation interventions. The guidelines are followed by a detailed commentary. This document establishes the major criteria for the conservation of China's cultural heritage and for the evaluation of the conservation work.

Prior to drafting the China Principles, the Dunhuang Academy and the Getty Conservation Institute conducted collaborative fieldwork for more than ten years. In order to apply and demonstrate the feasibility and authority of the China Principles, the Dunhuang Academy, the GCI, and the Australian Heritage Commission planned a joint effort that led ultimately to the initiation of the Mogao Grottoes Conservation and Management Master Plan. After extensive

discussions on the international level and revisions, the master plan became the first document of its kind in China to be written in accordance with the China Principles. To comply with the requirements of China’s cultural heritage law, the Mogao master plan (covering the period 2006–25) was further developed by the China Architectural Design Institute, an authorized planning entity, and approved after revisions as a legal instrument in February 2006.

Establishing the Master Plan for the Mogao Grottoes

The Mogao Grottoes of Dunhuang are a world-famous cultural heritage site representing a millennium of construction, from the fourth to the fourteenth century C.E. Over this period a rich deposit of historical data from various ages and a unique natural and cultural landscape was formed. The artistic, historic, and scientific values of the grottoes rank them among the most important cultural heritage sites in the world. Protection of the Mogao Grottoes is a responsibility that history has conferred on us. Yet, in spite of the great achievements of the Dunhuang Academy during the sixty years since its establishment, we have struggled with questions concerning the grottoes’ conservation, the methods that may appropriately be used to maintain the authenticity and integrity of the site, the principles and procedures we must follow, and the many complex factors that must be taken into consideration when intervening in the physical fabric, so as not to inadvertently or irreversibly diminish the significance.

As stated in the China Principles, conservation refers to all measures carried out to preserve the physical remains of sites and their historic settings. Therefore, the work requires arduous effort, investigation, discussion, and assessment. The initiation of a detailed plan is a necessary step. Article 9 of the China Principles states that all cultural heritage conservation work should be supervised by a systematic process, and the document’s commentary also requires that all heritage conservation organizations draw up a conservation master plan.

According to the China Principles, a master plan must include four elements: conservation measures, use, interpretation, and management. Its major contents and execution stages are research data collection, assessments of existing condition and management facilities, the establishment of goals, and the principles by which the goals can be reached. This is followed by the determination of specific objectives and the means of achieving them. The conservation process is summarized in table 1 and discussed in detail below as it applies to the Mogao Grottoes.

Significance Assessment and Assessments of Existing Condition and Management Context

Article 11 of the China Principles states that the assessment process consists of determining the values of the site, its state of preservation, and its management context. A proper assessment entails possession of comprehensive data, careful scrutiny of the data, and explanation of the value and meaning of the historical site. Therefore, a complete, accurate,

Table 1 Flowchart of the Conservation Process

Significance assessment		Assessments of existing condition and management context	
↓			
Statement of goals and the principles to be followed in achieving the goals			
↓			
Determination of objectives for 2001–10			
↓			
Establishment of Objectives and Action Plans			
Conservation subplan	Landscape and setting	Research subplan	Visitor management and interpretation subplan
Operations and management subplan	Maintenance and monitoring subplan	Staff professional training subplan	Infrastructure development subplan

and truthful collection of data is the very basis for the plan. Article 13 states that the preparation of a conservation master plan must be based on the results of the assessment.

The data collection work for the Mogao Grottoes addressed such issues as the meaning and value of the site's cultural heritage, history and state of preservation, daily maintenance, environment and setting, visitor management, exhibition display, infrastructure, construction, and operations management. This includes written documents, oral presentations, historic images and mapping information, and archaeological and technical information. The data range from historical records to current protection and management documentation. Research conducted by national and international experts on the art and artifacts in the Mogao Grottoes and the documents discovered and excavated at the site over the past century are enormous achievements, and a great deal of experience and technical information has been accumulated by the conservation work conducted at the site over the past sixty years. These constitute the foundation for the initiation of the Mogao Grottoes master plan.

Article 5 of the China Principles states that the assessment of the significance of a site should be given the highest priority throughout the entire process, since the depth and range of the understanding of the heritage art and artifacts have a direct effect on the conservation work. The values assessment was therefore of top priority in writing the master plan. With a long history and rich contents, the Mogao Grottoes and the surrounding environment have unique and multiple values, which it was important to identify. During the Mogao assessment, special effort was made to delve into the site's particular historic, artistic, social, and research significance.

Values assessment requires a long and continuous effort; the longer it takes, the more profound the results. This means that our evaluation was accompanied by unremitting research. The research work we carried out deepened our understanding of the Mogao Grottoes' cultural values, uniqueness, richness, and meaning for the world today.

In order to make the correct decisions for the conservation and management of the site, adequate assessments of the existing physical condition and the present management capabilities were also of great importance. First, the advantages and the disadvantages of conservation treatments had to be scrupulously analyzed. For example, it was determined which caves were stable and which were deteriorating. Analysis included understanding whether the condition had existed for a long time or is recent, whether the deterioration

is proceeding quickly, and the causes of the deterioration. All these issues were scientifically examined, measured, and understood.

Second, preservation of cultural heritage is closely related to the surrounding environment. The natural environment and the climate and its impact at Mogao were taken into consideration, as was the pressure of tourism.

Third, several different, or even conflicting, possible actions may follow from the assessments, and which measures are to be adopted is again guided by relevant laws and regulations. Daily maintenance of the site, environmental management, exhibitions for visitors, visitor management and services, academic research, staff training, legal status of the site, infrastructure development, and funding exerted significant influence on the execution of the Mogao Grottoes master plan. Thus all these factors deserved a place in the assessments. Management capabilities were, and will continue to be, of tremendous importance for the preservation of the caves and deserved equal attention.

To sum up, full assessment of the cultural significance of the Mogao Grottoes promoted understanding of the unique, priceless, and plural values of the site; the assessment of the state of preservation promoted understanding of the problems we are now facing; and the assessment of the management context helped us to realize the determining elements in the site's conservation and the limitations constraining our work.

Statement of Goals and the Principles to Be Followed in Achieving the Goals

Article 2 of the China Principles states that "the aim of conservation is to preserve the authenticity of all the elements of the entire heritage site and to retain for the future its historic information and all its values." Article 4 states that heritage sites should be used in a rational manner for the benefit of society.

These principles are the soul of the master plan. The fundamental aim for the conservation of the grottoes is to maintain and sustain all the historic information and cultural values that the caves carry today. Thus all possible measures should be taken to prevent natural and human damage to the caves and to use them, to the greatest possible degree, for the cultural education of society. Full-scale research into the rich resources of the grottoes is also necessary to promote Dunhuang studies at the international level. Based on the guidelines in the China Principles and on the assessment results, especially the problems we are faced with

in the protection of the grottoes, a program for 2001–10 was initiated, with the following four goals:

1. Conservation: to prevent the art and artifacts at the site from further deterioration by means of advanced technology, repair, daily maintenance, visitor management, and security measures;
2. Research: to promote Dunhuang studies and to expand human knowledge in general by means of a systematic study of the Mogao Grottoes and the historical records from the caves;
3. Education: to promote awareness and understanding of the value of the grottoes on an international scale;
4. Repatriation of dispersed documents and artifacts: although difficult at this time, the Dunhuang Academy has the long-term goal of collecting all materials currently in other countries so as to facilitate their systematic management and research work.

To achieve these goals and to avoid conservation and management errors, the Mogao Grottoes master plan has identified some necessary conservation principles. According to procedures outlined in the China Principles and based on the results of significance and condition assessments of the Mogao Grottoes, fourteen principles were determined. The principles explain why the site should be protected, how to protect the cultural heritage, what can be done, what must be done, and what must be avoided in order to maintain the integrity of the grottoes. The principles are summed up in the following four points:

1. Application of the master plan shall comply with the laws of the PRC concerning cultural heritage protection, the China Principles, international agreements on world cultural and natural heritage, and other relevant rules and regulations.
2. All conservation of and management interventions in the cultural heritage should have as little impact as possible; all activities, strategies, and measures should not damage the cultural values of the site; and all conservation interventions should be tested and evaluated beforehand.
3. The original landscape of the site and its surroundings should be preserved to the highest degree possible, no construction that interferes with the view

shall be undertaken, and no commercial activities shall be conducted in front of or near the grottoes.

4. Use of the site should be appropriate to its cultural values, and the number of tourists shall be limited to the carrying capacity of the caves.

Determination of Objectives for 2001–2010

Except for the fourth goal described above (repatriation of dispersed documents and artifacts), all goals are to be achieved in the ten-year period 2001–10. For the first goal (conservation), effective measures should be taken to protect the grottoes and their surroundings and to guarantee their daily maintenance; for the second goal (research), more effort should be made to promote Dunhuang studies in all aspects; and for the third goal (education), attracting tourists and providing exhibits should be coordinated on a scientific basis.

To achieve these three targets, management work, infrastructure development, daily operations, and staff training should all be kept in pace with one another. Accordingly, eight objectives have been determined: (1) conservation; (2) maintenance and monitoring; (3) landscape and setting; (4) research; (5) visitor management, interpretation, and exhibitions; (6) operations and management; (7) professional training for staff; and (8) infrastructure development. These objectives are coordinated through several substantive executive measures. The choice of measures required careful consideration and was based on the prerequisite of no damage to and minimization of impact on the site; at the same time attention was paid to ensuring the protection of the site's cultural values.

Using visitor management (objective 5) as an example, I highlight below the disadvantages related to tourism.

From the perspective of the master plan, the constraints are as follows:

- Most of the caves are too small for large numbers of tourists, and the number of caves that can be opened for visitors is limited.
- During the high tourist season, the temperature, humidity, carbon dioxide, and dust increase in the caves, which does great harm to the wall paintings.
- Overuse allows the caves no recovery time.
- Noise resulting from tourism activities may cause damaging vibration.
- Exposure to light, both sunlight and artificial, harms the paintings.

- The protective glass barriers inside the grottoes hamper visibility and, if broken, may damage the wall paintings.
- Lack of communication with travel agencies results in lack of information about the number and type of visitors.

From the perspective of visitors, the disadvantages are as follows:

- Dim light in the caves, lack of fresh air, and noise all diminish the quality of the visit.
- Walkways connecting the caves are narrow and result in congestion.
- The site lacks rational visitor routes to the caves and strictly enforced measures for routing on the site.
- The site lacks signs in foreign languages and internationally recognized informational symbols.
- The site lacks an efficient service center and information board.
- There is no relevant brochure or guidebook for the site.
- There is no high-tech facility for exhibits.
- The site lacks a program for educating tourists about the importance of preservation.
- There are inadequate restaurants and restrooms.

According to the Mogao Grottoes master plan, with respect to tourism, the objectives of visitor management are

- to restrict the number of visitors to the carrying capacity of the caves;
- to reasonably adjust visiting times so that visitation is better distributed throughout the year;
- to make available to visitors information on all aspects of the Mogao Grottoes, including history, art, culture, and preservation;
- to improve visiting conditions; and
- to develop a detailed plan for educating visitors about the caves and their preservation.

Substantial measures should be executed concerning each of the objectives of visitor management described above. For example, to make information available to visitors, we will develop a detailed plan for site interpretation; set up a visitor service center to inform visitors about the exhibitions at the site; design several visitor routes through the site; open more grottoes to visitors, in particular, those on the upper and middle tiers; and create more replica grottoes in the exhibition center.

Establishment of Objectives and Action Plans

According to Article 13 of the China Principles, specific plans for particular areas and components of a site shall be addressed with special action plans (known as subplans). The enormous scale and complexity of conservation work at the Mogao Grottoes required various subplans that correspond to specific areas of need and relevance. These were created after completion of the master plan. At present, a visitor management and exhibition subplan is being developed. In addition, we are executing and simultaneously improving the protection and management of the site as specified in the master plan. For example, measures are being taken to protect the caves from sandstorms, reduce humidity in the caves, and address the geologic instability of the cliff the deterioration of wall paintings. We are also conducting research into the carrying capacity of the grottoes in order to arrive at a safe number of visitors. The surrounding environment of certain important areas has also greatly improved. In accordance with the conservation subplan, we are developing professional conservation practices.

Conclusion

The master plan for the Mogao Grottoes has laid a solid foundation for the authentic and complete preservation of this historic site. Participation in the development of the master plan has helped us to improve our conservation capabilities. More important, it has brought our work to the attention of the government, our professional colleagues, and the general public. In recent years, the master plan has been applied to all areas of conservation and management work at the Mogao Grottoes, yielding many productive results.

Managing Cultural Heritage Sites: Some Parameters for Success

Sharon Sullivan

Abstract: *Modern heritage site management has developed gradually and is now a recognizable practice throughout the world. Yet it can hardly be said that site management is universally successful and well practiced. Some sites, while officially “managed,” are totally neglected or seem mired in a bog of bureaucratic inertia. Others have become elements of the local economy to such an extent that their integrity is being sacrificed to tourism. Still others are so lovingly “restored” that they seem to no longer have the values for which they are being managed.*

This paper examines some of the parameters and characteristics of successful site management that facilitate the long-term conservation of all of a site’s cultural values. It is based on an informal study of heritage sites in a range of cultural, political, and physical environments, and it uses examples of current site management in China and elsewhere to examine what constitutes successful heritage site management. In addition to good conservation policy and practice promulgated by such documents as the Burra Charter and the China Principles, key factors important in the recipe for successful site management include national and regional heritage policy and support, local community involvement and support, visitor management, funding and security, technical expertise, and staff motivation, skills, and teamwork. The importance of all these factors is discussed in this paper.

Modern cultural heritage site management has developed gradually and is now a recognizable practice throughout the world. Yet it can hardly be said that site management is universally successful and well practiced. Some sites, while officially “managed,” are totally neglected or seem mired in a bog

of bureaucratic inertia. Others have become elements of the local economy to such an extent that their integrity is being sacrificed to tourism. Still others are so lovingly “restored” that they seem to no longer have the values for which they are being managed.

This paper discusses heritage site management and its relationship to physical conservation, its importance for the ongoing sustainability of a site, and the key parameters for successful management that I see emerging in the twenty-first century. Before going further, I would like to define a few of the concepts I use.

- *Heritage site (or place).*¹ This is a site, area, or region that represents a particular focus of past human activity that we recognize as having important cultural values and that we wish to conserve. Such a site may have significant physical remains or no visible evidence of human activity, being rather the location of a past event of importance or the embodiment of a particular belief or legend. Stories, traditional uses, emotions, rituals, customs, and activities associated with the site can be an important part of its cultural heritage value. Here I restrict my discussions to heritage sites that have been recognized as having a sufficient degree of heritage value to have been given statutory protection and a management body charged with caring for them.
- *Conservation (or preservation, as it is often referred to in North American literature).* In its broad sense, as defined in the Burra Charter (Australia ICOMOS 2000),² conservation means all the processes of

looking after a site so as to retain its heritage significance. It may, according to circumstances, include the processes of retention or reintroduction of use, retention of association and meanings, maintenance, preservation, restoration, reconstruction, adaptation, interpretation, and ongoing management; it will commonly include a combination of more than one of these.

- *Heritage site management.* This is an integral part of conservation, and in this context *conservation* and *management* are often used interchangeably. If there is a difference, it is in our perception of scope. We generally regard conservation as the direct actions taken to conserve the site; management includes these actions but also a broader range of actions that will contribute indirectly to the conservation and sustainability of the site. In the China Principles (Agnew and Demas 2004),³ we find the concept *baohu cuoshi* (lit., “conserve + measures”), which conveys roughly the same meaning. The China Principles recognize the importance of heritage management and give management more emphasis than any other comparable charter. The degree to which a site’s management facilitates the long-term conservation and presentation of all its heritage values in a dynamic and integrated way determines the management’s success or failure.

Physical Conservation and Heritage Management

In this paper I use the term *physical conservation* to more narrowly denote conservation that involves physical intervention of some sort, that is, prevention of future deterioration such as by stabilization or restoration of the site’s fabric, which is its physical manifestation of heritage. In the popular mind, looking after a site properly principally means carrying out physical conservation, and the key role of those in charge of heritage sites is considered one of stabilization and restoration.

At a great site such as Mogao, we are struck immediately by the age, richness, beauty, and significance of the fabric. We also know that this precious fabric is fragile, damaged, and threatened. It is built into an unstable cliff face, on the edge of a great desert, affected by wind erosion and sand abrasion, by water damage and salt accretion, by the depredations of humans in the past and by possible overuse in the future.

In these circumstances the first priority for the managers of Mogao has rightly been the physical conservation of this fabric. The earliest efforts focused on stabilizing the cliff face, securing the caves against weathering, and basic stabilization of the painted walls and statues, along with meticulous systematic recording. A physical conservation research facility was quickly established, and work progressed from basic, emergency efforts, carried out under very difficult conditions, through a period of experimentation and learning, to the current situation of state-of-the-art work. At Mogao the senior staff are qualified experts with training in archaeology, physical conservation, historical research, and other relevant professional skills.

International partners such as the Getty Conservation Institute (GCI) were recruited to assist in this massive work of physical conservation. Examples of the innovative solutions applied to the Mogao Grottoes include a sand fence and vegetation line (Agnew 1996) and the seven years of work on cave 85 conducted jointly by the Dunhuang Academy and the GCI (described elsewhere in this volume).

As at Mogao, the perilous physical state of many great monuments of the world has meant that the first priority has often been given to conservation of the fabric. All this work was essential, and its achievement (as at Mogao) was often a necessary foundation for site conservation. My point is not that this was improper but that the attention paid to physical conservation historically has weighted the management of sites in this direction, with the key personnel being concerned with this aspect of site management and in many cases having this as their area of expertise.

Because of this emphasis, physical conservation at heritage sites has been through a long period of learning by mistakes as well as successes. The Venice Charter was developed because of the necessity to refine and control conservation practice (Sullivan 2003). The field of physical conservation has developed a firm set of ethics and principles, and it has become a discipline with a well-developed theory and practice that is increasingly rigorous and sophisticated. High-quality university-level training and graduate and postgraduate research work are regularly undertaken in this area, and the profession of conservator is well known and respected in the heritage world.

We can contrast this with the amount of attention that historically has been paid to the development of the broad discipline of heritage site management and its more specific aspects, such as personnel management, visitor and tourism management, routine maintenance, infrastructure

development, interpretation, and stakeholder and local community liaison. There are as yet few general heritage management courses, especially in China, and aspects of management other than physical conservation are sometimes seen as less prestigious, less glamorous, and less crucial to the conservation of heritage sites. This means that they are accorded less status, have less expert staff, and in general suffer from a lack of coordination and recognition.

Yet good general heritage site management, with its emphasis on utilitarian issues such as water supply or crowd control, is as crucial for the ongoing well-being and sustainability of a heritage site as is good physical conservation. And, in fact, effective heritage site management can be seen as a sheltering umbrella under which good and well-judged physical conservation can be carried out while at the same time the need for it is minimized. No prudent conservator looking for long-term results would undertake a major physical conservation program at a poorly managed site.

Urgent Need for Site Management

In many parts of the world, the requirement for good management is becoming urgent, since pressures on heritage sites are increasingly caused by overuse, misuse, national or regional development aspirations, and the often desperate needs of local people. China faces many of these problems, and we can see them being effectively addressed at Mogao. Yet it can hardly be said that heritage site management is universally as successful and well practiced as in China. We can all think of heritage sites that are poorly managed. Some sites are totally neglected or seem mired in a bog of bureaucratic inertia. Others have become elements of the local economy to such an extent that their integrity has been sacrificed to tourism (for examples, see Guolong Lai, Demas, and Agnew 2004). Some sites totally exclude or indeed make enemies of the traditional owners and the local population (see Munjeri 2004).

Challenges Facing Heritage Site Management at the National and International Levels

Successful heritage site management faces numerous challenges caused by external factors. In particular, it is very difficult, though not impossible, to effectively manage a site in a legislative and policy vacuum. There are exceptional managers who achieve this, but the odds are stacked against them. This

has been an ongoing problem in the UNESCO approach to encouraging good heritage site management among member states. UNESCO relies almost solely on the limited scope of the World Heritage Convention (UNESCO 1972) to influence site management. The Convention obliges signatory countries to establish a management regime aimed at the protection of those selected sites deemed by the World Heritage Committee “of outstanding universal value.” The Convention, however, is silent about conserving and managing sites and landscapes that are not destined for the World Heritage List but that together make up a nation’s cultural heritage.

This situation contrasts sharply with the protection of natural sites of outstanding universal value. In this case, the World Heritage Convention is backed up by UNESCO’s Man and the Biosphere Programme (www.cbd.int/convention.shtml#), which protects a much wider group of ecosystems known as Biosphere Reserves, and the Convention on Biological Diversity (UNEP 1992), under which each signatory nation agrees to establish site measures for the general protection of biodiversity wherever it occurs.

This gap in the international arrangements for the protection of cultural heritage has had disastrous management consequences for both heritage sites and landscapes generally and for many World Heritage Sites. When sites are declared World Heritage and there is no overarching national heritage protection policy or regime, they are often inundated by tourists and developers and expected to raise revenue and reflect national prestige for the state while at the same time their conservation is neglected.

Proper heritage site management needs the support and protection of overarching regional and national policy and regulation, as well as expert and administrative support systems. This should ideally include public recognition by the government of the cultural, social, and economic values of the nation’s cultural heritage generally and the development of an effective legislative and administrative regime to conserve it. If no general recording and assessment have been made of the country’s heritage, it is difficult for the manager to assess the significance of and interpret a particular heritage site. It is equally difficult, in the absence of general policies and programs, for an individual manager to liaise with the local community and to educate and involve them. Most crucially, without such a system of policies and programs, the heritage manager is isolated and unsupported at a political level. Funding is generally inadequate or lacking, and no network of expertise, support, or assistance is available.

Without the proper regulatory and support systems, the management of a particular site is often ineffective and short term. This was seen during the early conservation and management work at Olduvai, Tanzania, where important fossil sites were protected by erecting shelters. No regulatory and support systems were in place to manage the sites or to maintain the shelters, nor was there a program or policy that explained to the local community the nature of the fossil remains and the need for their protection. Consequently, the shelters have been destroyed or left to decay, and the sites, having had public attention drawn to them, are probably in a worse state than before their attempted protection (I learned of this firsthand while visiting the sites).

In contrast to the situation at Olduvai, the People's Republic of China's commitment to cultural heritage, its strong legislation, its national and regional management system, the recent adoption of the China Principles, and a bureaucratic and expert support system for sites such as Mogao make good heritage management possible and frequently apparent in China.

Good Heritage Site Management: The Essential Elements

Recognizing the Complexity of the Management Role

Successful heritage site management can be defined quite simply as the long-term conservation of all the cultural values of a site. Successful site management, however, is complex and multifaceted, and all its elements are interconnected. On-site we are dealing with a web of cultural values, with technical, social, and political problems and opportunities, as well as resource needs, and with the multiple cultural and economic connections between the heritage site and the local and broader community. All these factors are constantly changing, and the site manager needs to take them all into account to ensure long-term conservation.

While successful site management involves expert care of the site's fabric, in which many senior managers are highly qualified and skilled, it also involves dealing with issues as diverse as tourism pressure; landscaping; water management; financial management and fund-raising; liaising with the local community; finding ways to meet the needs of regional government and the tourism industry without compromising cultural values; running a training school for guides and managing visitors; designing and installing exhibitions; dealing with ongoing and regular maintenance,

aging infrastructure, and staff amenities and accommodation; and conducting conservation and academic research.

This point may seem obvious, but many managers and management structures are ill equipped to deal with this level of complexity. By concentrating on a narrow range of issues, often relating to fabric conservation, and neglecting many other elements of site management, they allow significant damage and deterioration of the site and the development of political or social issues that can endanger its long-term viability.

Finding Effective Tools to Manage Complexity

The first prerequisite for managing effectively in this complex situation is a set of principles and procedures that dissects the levels of complexity and allows an understanding of their interconnectedness, thus providing a framework for good decision making. Otherwise, there is a danger that certain problems will dominate all others, that they will be misunderstood, or that in dealing with the complexity of day-to-day issues the site manager will lose focus on the key reason for the work—the conservation of significance. Well-managed sites have a system of sifting through this complexity so that key priorities and issues emerge clearly. This framework, which is outlined in the Burra Charter and the China Principles, is illustrated by the master plan for the Mogao Grottoes (see Altenburg et al., this volume).

In brief, the day-to-day management of a heritage site, including crucial decisions that need to be made about its development or restoration or about changes to it, must be based on accurately assessing and recognizing all its cultural values, researching and assessing conservation management issues and opportunities, and exercising problem-solving skills to produce policies and strategies that result in the conservation of all its cultural values.

Identifying Values

It is now well accepted that values-based management is the key to effective conservation (see Sullivan 1997a, 1997b; Clarke 1999; Avrami, Mason, and de la Torre 2000). At many sites cultural values arise at least in part from the traditions and practices of the community, and to keep these values alive, dynamic interaction is needed with the community from which they emanate. So an assessment of values, which not only relies on the opinion of experts but also takes into account the views of the site's community and traditional

owners, is a crucial first step in good management. This has implications for the role of the site and the manager in the community, which is discussed later.

Revisions to the Burra Charter recognize the reintroduction of traditional use and the retention of association and meanings as being in many cases as important for the conservation of the site's values as protection of the site's fabric (see Walker and Marquis-Kyle 2004). A properly conducted values assessment identifies all elements of cultural significance that a site possesses and recognizes the implications for management, including potential management conflicts between these values. This assessment can be complex and difficult, because it involves making judgments about sometimes conflicting data and working with stakeholders with a broad range of views and values, but it avoids the trap of seeing heritage sites in a one-dimensional or limited way. It is crucial that the key stakeholders—those groups in the community that have traditional associations with the site or an interest in or influence on the site—and the site's management (defined in more detail later) understand and accept all the cultural values of the site.

The New South Wales National Parks and Wildlife Service is currently preparing a new management plan for Kosciuszko National Park, a huge alpine landscape in southeastern New South Wales. The park managers had previously recognized the existence of cultural heritage sites within the park, but they had tended to downplay the traditional connections of the Aboriginal people and the local descendants of settlers with the park in order to stress its pristine natural values and because some of the cultural heritage values were considered to be in conflict with these natural values.

Only in the new management plan have the park managers acknowledged the contemporary importance of the park's cultural landscape to Aboriginal and settler populations who generated this landscape and who still have living cultural connections with it. Partnerships with local communities, families, and individuals with strong connections to the park not only acknowledge the legitimacy and authenticity of the histories; they also provide the best means of ensuring that the diversity of cultural values associated with the park survives (Sullivan and Lennon 2003).

The values described in the new management plan were developed with input from a community forum, an independent scientific committee, and an Aboriginal working group. The plan acknowledges that park management will be based on recognition that all elements of the landscape had been influenced by human activities to varying

degrees and that the traditions associated with this landscape are still strong and legitimate. One tangible policy result is the decision to allow ongoing use, maintenance, and, in some cases, restoration or reconstruction of traditional mountain huts where there is still a living family tradition of use and association.

This project has had immense benefits. Not only has the cultural significance of Kosciuszko National Park been greatly enriched, but the stories of its traditional owners have been legitimized. The groups with traditional ties to the site now have a certain degree of ownership of the plan and the management process. Rather than oppose elements of park management, they have become to some extent allies of effective park management (Lennon 2005; for discussion of similar issues in China, see Han Feng 2005).

At a well-managed site recognition is also given to the importance of economic values, and the site is managed to maintain or, in some cases, enhance them. In the case of legally designated heritage sites, however, economic values are derived values that arise from the cultural significance of the site; in the long run, they will exist only as long as the cultural significance is conserved. For an interesting case study of managing a balance between the cultural and economic values of a site, see the case study on Port Arthur in Tasmania (Mason, Myers, and de la Torre 2005: 116–69).

Identifying and Researching Issues and Opportunities

Another element of successful site management is a realistic and full assessment of the issues, problems, and opportunities of the management environment. Conserving the values of a site relies on identifying and solving issues and problems that threaten these values. Managers often feel that they instinctively know what these issues are, but this is not always the case. Good research has long been recognized as a prerequisite to physical conservation work, but it equally needs to be a prerequisite to heritage management in general. The manager needs to know details such as financial projections; visitor numbers, behavior, and profile; makeup and strengths and weaknesses of the management team's experience; infrastructure issues; local community expectations; and political and social attitudes.

One problem of management assessment work is that identifying unsolved issues can be politically unwelcome and can be taken as a sign that the manager has failed in some way. But good management requires that the same objectivity be applied to researching these issues as to researching the condition of the site's fabric.

A good example of management research is described in the paper on visitor surveys in this volume by Li Ping and colleagues. Detailed surveys and observations of visitors at the Mogao caves, carried out as part of the management assessment for the Mogao master plan, provided new data about visitor trends, behavior, expectations, attitudes toward conservation, and satisfaction level. These surveys in turn provided vital information for planning for future conservation of the wall paintings, management, and visitor education. For instance, observations of visitors during the height of the tourism season revealed that even under supervision, 3.9 percent of visitors (708 people) touched the surfaces of the wall paintings. This was due in part to overcrowding during certain parts of the day, and strategies are now being developed to resolve this issue.

Developing Realistic Policies and Strategies

Identifying a site's values and its management and conservation issues needs to be followed by the development of policies and strategies aimed at the maximum conservation of all site values. This requires a site manager with flexibility, strong problem-solving skills, tolerance of uncertainty and change, and pragmatism about what needs to be achieved, with the overall aim of conserving the site's cultural values.

The development of policies and strategies is an ongoing process that all successful site managers engage in whether or not they have reached the stage of producing a formal management plan. Successfully handling this process, by whatever means, is much more important than having a beautiful plan. The process is iterative and does not have a finite end. One key factor in its success is recognizing that the situation is so complex that it is often crucial to establish priorities and to proceed in small steps to effect incremental improvements rather than expect all problems to be solved in the short term.

The successful site manager practices the art of the possible. Solutions must be feasible and practical. This often means not being seduced by advanced technology, or by elaborate schemes that may look good but are beyond the capacity of the site's resources. On the other hand, even small changes can have a dramatic effect and can be built on to continue to improve the management situation. At Mogao, for example, the requirement that all incoming tourist groups book at least one day in advance has dramatically reduced crowding and greatly improved the visitor experience. Though this was a simple change, its implementation called for strategic thinking, a good communications strategy, teamwork, and some significant risk management by senior staff.

Making Site Management Work

So far I have discussed a process for heritage site management that is increasingly recognized in documents such as the China Principles, the English Heritage planning principles (Heritage Lottery Fund 1998), and the Burra Charter. But these documents do not cover some important elements of good management, that is, how to make the process work in practice to achieve a successful result. I want to discuss some of these issues now.

Involving Staff

A management structure that allows the processes of significance assessment, issues analysis, and developing policies and strategies outlined above to be understood by all staff members, and to be owned and worked on by them, is essential for good management. Specialists have a significant role in site management, but the interdependence of all the measures that need to be put in place to conserve a site means that staff in all the management departments (in China, this is commonly conservation, visitor reception, security, museum management, and artifact curation) need to have an understanding of and a commitment to the key elements of the significance of the site, the key management and conservation issues facing the site, and the proposed solutions and their priority and timing.

The only way to effectively achieve this understanding and commitment is to involve staff from all key management areas in the site's values assessment and consequent decision-making processes. Staff need to be able to provide input informed by their expertise or experience; to be involved in the research needed to tease out and quantify issues; and to be convinced about and committed to the solutions. In many instances, such a process will reveal gaps in needed expertise or actual management presence that can then be rectified. For example, in China there is often no expertise in visitor management, but recognition of this fact makes it possible to bring in the missing expertise or to train key personnel.

Beginning this process of involvement is often difficult. It cuts across many entrenched practices and expectations, and it can bring to light deeply buried and significant issues. Such a process can also be threatening to the most qualified and specialized members of the management team, who may feel a loss of control. It can also be threatening to staff, such as the works supervisor or the accountant, who have never been involved in the larger site issues and who may not feel responsible for them or competent to address them. With

good leadership, however, this process is empowering and can immensely strengthen the capacity of managers to carry out effective conservation measures. It also almost invariably raises staff morale and their level of responsibility and initiative.

The aim of inclusive involvement is to build up within the organization a culture of staff dedication to excellence in site conservation that acknowledges the role of every individual. Once established, such a culture will become self-sustaining, because staff developed and treated in this way acquire a genuine love of their work and of the site, and they develop initiative and problem-solving skills that can often protect the site from threats such as political interference or loss of resources. This is why bringing in a consultant to solve problems or write a management plan will produce a missed opportunity to involve all staff and will rarely be successful. Without staff involvement, good management is very difficult, and it is likely to be temporary, dependent on the whims and skills of a particular manager. Thus development of staff expertise, involvement, morale, and understanding is an essential part of the conservation strategy for every site.

Good conservation arises from careful consideration of all the values in conjunction with the circumstances of the time. Detailed rules that do not take account of this inevitably become more and more rigid and fossilize the conservation effort. Managers should instead invest in ongoing awareness raising and training for staff, all of whom are custodians of the site's values. The achievement of staff commitment and management expertise is an essential part of the conservation planning and implementation process.

The Old Parliament House in Canberra, Australia, is an example of how to successfully involve staff in managing a site. This is Australia's first permanent Parliament House, and its fabric and associations have a high cultural significance for most Australians. Many visitors come to this site; schoolchildren reenact parliamentary debates here, many exhibitions and public functions are held here, and it is the home of the National Portrait Gallery. The fabric of the Old Parliament House is very important, but equally important to its continuing cultural significance are good public access, keeping it a lively and vibrant place, and using modern technology to tell its story and educate its visitors. Interaction with visitors and the place's present physical configuration and ambience are an important part of its significance.

A thorough analysis of the significance of nearly every room of the Old Parliament House and a detailed conservation plan for its fabric had been developed. Responding to

the data, however, resulted in a complex range of operational rules relating to fabric conservation that gradually tied down managers, making day-to-day planning and decision making very difficult. Consequently, staff trying to operate the building felt restricted and hampered in their efforts to keep the site alive and relevant for its public.

This situation was resolved by developing a new conservation plan through a series of workshops with staff and management. The new plan emphasizes a relatively simple decision-making process: for any action staff may undertake, they need to consider if it is likely to enhance or threaten elements of the cultural value of the site. All staff are not experts in conservation, or in the detailed history of the site, but all are now familiar with the major elements of the significance of the building, and all have a responsibility for conducting an assessment based on this as a first step in their planning, whether for a new exhibition, the installation of audiovisual equipment, or a proposed function. The staff assessment is then discussed with the site's heritage experts before a decision is made. If necessary, the proposed action is revised or an alternative solution found. The result of this new system is that all key staff are partners in the job of significance conservation, take this into account in all decision making, and feel less constrained and much more aware of the reasons for conservation decisions (Godden Mackay Logan Heritage Consultants 2005).

Engaging the Local Community

A heritage site is essentially a part of the community, in the final analysis owned by that community and not by the manager or by the government. The site is the living link between the community and its heritage; it animates this heritage and is the ultimate basis for all the more formal values we professionals give it.

Engaging the local community in decision making is often seen as a risky strategy by management staff, because it means giving up a degree of control to the local community or to other stakeholders, or at the very least involving them in discussions about significance or management. Management, however, must recognize that important aspects of a site's cultural value are in the custodianship of the community and that they must play the role of facilitator rather than boss or opponent in working with that community. Increasingly today the community is finding its voice, and it is dangerous to ignore it or attempt to sidestep it. A site's manager and staff may be able to come up with theoretically perfect solutions to certain management issues by excluding the community, but

the real danger exists that this may mean that crucial political and social support for the site is lost and, as a result, elements of its significance are endangered.

The word *community* is difficult to define. It can mean the general community (the citizens of the nation or state) or the particular community or social group associated with the heritage site. Among those who might have a legitimate connection to the site are the following:

- *local residents*, or those who live around the site or in associated local or regional centers;
- *people with traditional links to the site*, for example, traditional owners, relatives of historic figures associated with the site, people whose personal histories are connected to the site, members of a religion or society for which the site is significant;
- *people with particular knowledge about the site*, for example, long-term residents, local scholars, and custodians of information;
- *those who visit the site* to explore its cultural heritage or for relaxation or recreation; and
- *those with a statutory, political, or pecuniary interest in the site*, such as department officials, politicians, local leaders, businesspeople and developers, those in the tourism and accommodation industry.

All these groups are stakeholders. Successful management involves dealing effectively with all of these people, including difficult as well as helpful sections of the community. When these groups are involved in the consultation process they are able to feel part of the process and voice their legitimate concerns and needs. It also gives managers the opportunity to explain their point of view and to work toward a win-win solution to problems. Ideally, the manager should consult with stakeholders at every major step of the planning and implementation process, seeking views on the significance of the site, on the issues and opportunities relating to it, and on the proposed solutions.

It may seem that businesspeople, tourism operators, and developers should not have a place at the table during these discussions. Leaving them out, however, can result in their opposition to key conservation objectives (Sullivan 1997b). Though some of their motives may be exploitative, their cooperation can very often assist in finding good management solutions for the site. In the final analysis, the long-term conservation of the site is in the interest of these user groups and the site managers.

Effective community involvement does not mean that a manager relinquishes control, but it can lead to solutions that are less perfect than ones the manager may have been able to design in isolation. On the other hand, solving 80 percent of a problem, or moving in slow steps that the community can accept to overcome key issues, is much better than coming up with a “perfect” solution that cannot be implemented because of community opposition.

The experience of community involvement is very heartening. Gathering people around the table to discuss an issue in which all have an interest and giving them the opportunity to voice their own concerns and issues, if done in good faith, is less risky than one might think. Whenever I have involved the community in decision making it has resulted in overriding agreement that conservation of the site is important. After that, managing issues and finding solutions has been much more straightforward, as was the case at Kosciuszko National Park.

Local communities may be in desperate need of the basic requirements for a secure and minimally comfortable life. In these circumstances, understanding and embracing cultural heritage values and aspirations is not necessarily a priority, unless we can establish real congruence between heritage conservation and the needs of the community. Successful heritage site management will happen only when this is achieved. This is often difficult, especially in regimes where the local community is excluded from real decision making and consideration and the national interest is seen as paramount. The site manager is not a miracle worker, but it has been my experience that we can always involve the community at some level, even if it is at first difficult to achieve and initially produces a minimal outcome.

Finally, winning the confidence and support of the government officials and/or department to whom they are responsible is crucial to heritage site managers. This may not be easy, but site managers need to pay special attention to this relationship, through good communication, responsiveness, and low-key promotion of achievements and priorities for the heritage site.

Practicing Advocacy and Promotion

The successful heritage site manager practices advocacy. It is essential to actively promote the site’s values and its cultural and economic importance to the community and to the government. By this, I do not mean indiscriminate encouragement of visitors, or promotion of inappropriate use. I mean

well-planned and steady promotion to key stakeholders that is aimed at enhancing and reinforcing the site's values. A strategy to achieve this is essential and is actually part of conservation goals, since successful promotion of the site's values will enhance those values and help to secure their survival. For the manager, practicing advocacy and promotion may mean a variety of activities that at first sight do not appear to have a lot to do with heritage conservation.

Port Arthur in Tasmania is one of Australia's most important historic sites. It tells part of the story of the origins of the Australian nation as a penal colony designed by imperial Britain to solve the problem of the great crime wave that resulted from the displacement of people caused by the industrial revolution and from the continued subjugation of Ireland.

At the Port Arthur Historic Site, selling all the values of the site to a wider audience has played an important role in building support. The site managers have done this in a number of ways:

- by hosting a series of international conferences with invited scholars with expertise in the significance of the site, publishing the conference proceedings, and actively encouraging visits by international experts to the site;
- by operating a research center dedicated to convict studies in partnership with a number of universities, holding a series of summer schools for post-graduate students in archaeology and architecture, and operating a user-friendly service where visitors or members of the public can research their convict ancestry;
- by setting up a descendants group for people whose ancestors were at the site as convicts or staff, which has regular contact with the site, is consulted about management, and helps to promote the site nationally and internationally;
- by making the site available for local use through a variety of means, such as providing free entry, keys, fishing rights, and social activities and by maintaining the local parish church and cricket pitch; and
- by running an active program of conservation assistance for local people with heritage sites in the region and by playing an active role in heritage conservation in Tasmania generally.

The Port Arthur Historic Site has also contributed considerable funding and assistance to regional tourism efforts, and it promotes other tourist attractions in the region in conjunction with or as alternatives to the Port Arthur Historic Site. The site is actively involved in cultural events in Tasmania, hosts those that are congruent with the significance of the site, and promotes Tasmanian produce and crafts at the site.

Managers liaise frequently with Tasmanian and national politicians, community leaders, and heritage experts about the site's values and needs. They also take every opportunity to attend relevant conferences and speaking engagements.

Managers provide a continuous flow of positive news stories, actively promote on-site improvements, and ensure the attendance of key leaders and public figures at site events. Equally important, they deal quickly, honestly, and openly with any perceived problems with the management of the site or complaints from visitors or the community. The staff aims to treat visitors in such a way that more than 95 percent report that they had a memorable or very memorable experience and, consequently, act as ambassadors for the site and its management.

All these promotional activities are an important part of the site's conservation strategy: to explore and explain the value of Port Arthur as a heritage site with difficult and painful associations; to increase the public's understanding and appreciation of these associations; to explore issues related to conserving and presenting such sites; to provide input and involvement for locals; to draw international attention to the significance of Port Arthur; and to further increase government and local respect for the site's values.

Managing Financial Resources

Good resource management is essential. There is never enough money to operate a heritage site in the way management and staff feel it should be operated, but wise use of the resources that are available and taking opportunities to increase them are an essential part of the manager's role.

Successful site managers give priority to a realistic and carefully worked out budget that ensures that all available money is wisely spent on key priorities. It is important to put time and effort into presenting a convincing financial plan to government and other key sponsors of the site.

In a recent bid to persuade the Tasmanian government of the need for ongoing conservation funding, the Board of the Port Arthur Historic Site commissioned an indepen-

dent review of progress on its conservation plan objectives. In addition, a study by well-known economists produced a favorable picture of the benefits that the site brings to the local community and to Tasmania overall (Felmingham, Paulin, and Page 2004). This study demonstrated that the government's investment in the site to date had a significant multiplier effect on investment and job growth in the regional community, as well as a significant effect on Tasmania generally. Both the independent review and the economic study were influential in the site's successful bid for funding.

Conclusion

The aim of this paper is to show that the heritage site manager and the site's senior team require not only expertise in their particular disciplines but also a much greater range of skills and attributes to successfully carry out their complex and difficult roles. My experience indicates that the following are some of the qualities that make for successful site managers:

- vision
- integrity
- communication skills
- strategic and entrepreneurial skills
- leadership and teamwork
- problem-solving abilities
- flexibility and pragmatism

Above all, the manager needs the courage and skill to take the initiative in conserving and managing the site rather than simply reacting to problems and pressures as they arise. Having a vision for the site and moving steadily to implement it in the ways outlined above can produce powerful results.

Acknowledgments

I have been privileged to work with Neville Agnew and Martha Demas of the Getty Conservation Institute, with Kirsty Altenburg of the Australian Department of the Environment and Heritage, and with Chinese colleagues, especially Fan Jinshi, director of the Dunhuang Academy, in developing and applying the China Principles. The vision and ideas of this group have contributed greatly to the development of this paper.

Notes

- 1 Although heritage *site* is the more commonly used and understood terminology, the Burra Charter uses heritage *place* to mean the same thing.
- 2 The Burra Charter is a conservation charter developed by Australia ICOMOS and is widely used as a standard in Australia and internationally.
- 3 The China Principles are a set of heritage conservation principles developed by the Chinese cultural heritage authorities for use in China.

References

- Agnew, N., ed. 1996. *Conservation of Ancient Sites on the Silk Road: Proceedings of an International Conference on the Conservation of Grotto Sites*. Los Angeles: Getty Conservation Institute.
- Agnew, N., and M. Demas, eds. 2004. *Principles for the Conservation of Heritage Sites in China = Zhongguo wen wu gu ji bao hu zhun ze [Chinese-language document] issued by China ICOMOS; approved by the State Administration of Cultural Heritage*. Los Angeles: Getty Conservation Institute.
- Australia ICOMOS. 2000. *The Burra Charter: The Australia ICOMOS Charter for Places of Cultural Significance (1999): With Associated Guidelines and Code on the Ethics of Co-existence*. Burwood, Vic.: Australia ICOMOS. www.icomos.org/australia/burra.html.
- Avrami, E. C., R. Mason, and M. de la Torre. 2000. *Values and Heritage Conservation: Research Report*. Los Angeles: Getty Conservation Institute.
- Clarke, K., ed. 1999. *Conservation Plans in Action: Proceedings of the Oxford Conference*. London: English Heritage.
- Felmingham, B., D. Paulin, and B. Page. 2004. Contribution of the Port Arthur Historic Site to the welfare of Tasmania. Final Report to the Port Arthur Management Authority. Symetrics Business Intelligence Tasmania.
- Godden Mackay Logan Heritage Consultants. 2005. Old Parliament House Canberra Heritage Management Plan. Report prepared for Old Parliament House.
- Guolong Lai, M. Demas, and N. Agnew. 2004. Valuing the past in China: The seminal influence of Liang Sicheng on heritage conservation in China. *Orientations* 35 (2): 82–89.
- Han Feng. 2005. China's new wilderness. *Landscape Australia* 27 (105): 58–60.
- Heritage Lottery Fund. 1998. *Conservation Plans for Historic Places*. London: The Fund.
- Lennon, J. 2005. The evolution of landscape conservation in Australia: Reflections on the relationship of nature and culture.

- In *The Protected Landscape Approach Linking Nature, Culture and Community*, ed. J. Brown, N. Mitchell, and M. Beresford, 203–16. Gland, Switzerland: IUCN—World Conservation Union.
- Mason, R., D. Myers, and M. de la Torre. 2005. Port Arthur Historic Site. In *Heritage Values in Site Management: Four Case Studies*, ed. M. de la Torre, M. G. H. MacLean, R. Mason, and D. Myers, 116–69. Los Angeles: Getty Conservation Institute.
- Munjeri, D. 2004. Anchoring African cultural and natural heritage: The significance of local community awareness in the context of capacity-building. In *Linking Universal and Local Values: Managing a Sustainable Future for World Heritage = L'union des valeurs universelles et locales: La gestion d'un avenir durable pour le patrimoine mondial*, ed. E. de Merode, R. Smeets, and C. Westrik, 75–80. World Heritage Papers 13. Paris: UNESCO World Heritage Centre.
- Sullivan, S. 1997a. The management of ancient Chinese cave temples: A site-management training course at the Yungang Grottoes. In *Conservation of Ancient Places on the Silk Road: Proceedings of an International Conference on the Conservation of Grotto Sites*, ed. N. Agnew, 28–40. Los Angeles: Getty Conservation Institute.
- . 1997b. A planning model for the conservation of archaeological sites. In *The Conservation of Archaeological Places in the Mediterranean Region: An International Conference Organized by the Getty Conservation Institute and the J. Paul Getty Museum*, ed. M. de la Torre, 15–26. Los Angeles: Getty Conservation Institute.
- . 2003. Venice, Burra, and Kathmandu. In *The Sulima Pagoda: East Meets West in the Restoration of a Nepalese Temple*, ed. E. Theophile and N. Gutschow, 116–20. Trumbull, CT: Weatherhill.
- Sullivan, S., and J. Lennon. 2003. Cultural values. In *An Assessment of the Values of Kosciuszko National Park*, 181–227, ed. Independent Scientific Committee (N.S.W.). Queanbeyan, NSW: National Parks and Wildlife Service.
- United Nations Environment Programme (UNEP). 1992. Convention on Biological Diversity. www.cbd.int/convention/.
- UNESCO. 1972. Convention Concerning the Protection of the World Cultural and Natural Heritage. www.unesco.org/en/conventiontext/.
- Walker, M., and P. Marquis-Kyle. 2004. *The Illustrated Burra Charter: Good Practice for Heritage Places*. Burwood, Vic.: Australia ICOMOS.

China's Policy in Relation to International Exchange and Cooperation in Cultural Heritage Conservation in China

Zhang Wenbin

Abstract: *China's State Administration of Cultural Heritage (SACH) has adopted several measures to expand its international collaboration and exchange programs in the conservation and museum fields. It sought approval from the Standing Committee of the National People's Congress for China to be a signatory to the Convention Concerning the Protection of the World Cultural and Natural Heritage and to become a member of three major international organizations for the conservation of cultural heritage. SACH has organized well-received exhibitions of Chinese cultural artifacts, and it has encouraged and supported various forms and levels of international collaborative projects. It has also fostered collaborations on the scientific conservation and management of cultural relics to improve the quality of this work in China, as exemplified by the application of the Principles for the Conservation of Heritage Sites in China, issued by China ICOMOS, while actively promoting collaborative projects in field archaeology. Finally, it has promoted academic exchanges and study abroad. However, much work remains to be done. This paper proposes steps to be taken to improve China's participation in international conservation activities.*

Since implementation of China's policy of reform and openness to the outside world, the government has paid much more attention to international exchange and cooperation in support of cultural heritage conservation, and it has taken an active role in joining international activities in the fields of cultural heritage and museums. This has resulted in abundant benefits and considerable advances.

China's Growth in International Conservation Work

By 2000 China had signed four international treaties and joined three international organizations (ICOM, ICOMOS, and ICCROM) concerned with cultural heritage conservation and study. The UNESCO World Heritage Committee held a meeting in China in 2004, and ICOMOS held its 15th General Assembly in Xi'an in 2005.

The Chinese government actively seeks international cooperation to counter theft and smuggling of its cultural heritage, and a workshop on this subject was held with UNESCO. Furthermore, the government signed the Pact of Conservation and Reclaiming of Heritage with Peru in 2000. In regard to UNESCO's 1970 Convention on the Means of Prohibiting and Preventing the Illicit Import, Export and Transfer of Ownership of Cultural Property, the government requested of the United States a restriction on the import of cultural heritage items from China.

In recent years China has held many cultural heritage exhibitions abroad on various subjects. Both the response to these exhibitions and the social benefits derived from them have been great, especially in the China-France Cultural Year starting in 2003. Meanwhile, exhibitions held in China include the *Peru Cultural Heritage Exhibition*, the *Maya Civilization Exhibition*, the *Elite Exhibition of Japanese Cultural Heritage*, the *Egypt Cultural Heritage Exhibition*, and the *Ancient Roman Civilization Exhibition*.

China's government has aided a conservation project to protect a Cambodian temple at Angkor Wat, and the

project is nearly completed. The work of the Chinese engineers and workers has won trust and recognition from Cambodia. Now China and Cambodia have signed a new agreement for continuing cooperation.

More and more cooperative projects of various forms and at different levels are being submitted for approval to the central and local governments in China. For example, China and Italy have set up a Conservation Training Center at China's National Institute for the Conservation of Cultural Property in Beijing; experts from China, the United States, and Australia developed the *Principles for the Conservation of Heritage Sites in China* (the China Principles), which have been approved by the State Administration for Cultural Heritage (SACH) and formally issued in Chinese and English by China ICOMOS; and Chinese museums have expanded their exchanges on management, training, and academic study with several famous foreign museums.

In addition to the above, China's efforts in the area of archaeological investigation and excavation in cooperation with other countries have become established and effective, scientific technology and academic standards are being emphasized more and research directions clarified, and the scope of cooperation has been broadened. China's initiative to organize an archaeological team in Pakistan is progressing.

Challenges Facing China in Conservation Activities

Although international exchanges and cooperation related to conserving China's cultural heritage have become richer, with broader potential, problems and deficiencies remain. Some of these issues are summarized below.

Lack of a Strategic Structure and Action Plan

In 2001, at the national cultural heritage meeting on foreign affairs, SACH pointed out that the general goal of its work is to actively initiate improvements in the management and academic standards of activities in archaeology and museology, in order to advance the status of China's cultural heritage in the world. To realize this goal, we must develop a strategic structure and action plan, articulate heritage significance, prioritize work in a clear and consistent way, determine key points, establish operational criteria, and steadily improve performance.

Lack of Full Integration into the International Heritage Community

China has not yet fully entered the international heritage community, and it has not yet exerted influence appropriate to its vast heritage resources. China is a latecomer to the international heritage community. For historical reasons, her voice and influence are small, and the country's awareness and practice in cultural heritage conservation do not yet match that of the international heritage community, especially with regard to research and the ability to follow up on the newest trends. China is also hampered by its inability to set up effective and vital contacts with international organizations.

Poorly Implemented Regulations for Managing Overseas Exhibitions

Regulation and control of the export of cultural heritage artifacts and overseas exhibitions needs to be enhanced. The government has approved many large-scale exhibitions held overseas. However, the number of first-rank objects of national importance on exhibition has exceeded the quantity regulated by law, which increases risk. In addition, the Chinese government has not initiated most of these exhibitions; therefore, their location and timing were not logically arranged. Furthermore, security and safety for the objects were potential problems.

Lack of Knowledge about the International Conservation Community

All levels of China's heritage management units as well as individual professionals are not fully familiar with the relevant international conservation organizations, pacts and agreements, international cooperation requirements, and opportunities. Because of differences in history, culture, and language, China has difficulty working with international organizations and following international conventions. It is not uncommon for heritage management units and individuals to enthusiastically accept funding and gifts from foreign collaborators and volunteers while at the same time ignoring the specific requirements of the cooperation. Because of the substantial differences between Chinese and foreign experts in terms of capabilities and ideas about heritage conservation, collaborative projects often result in the two sides parting on bad terms. Furthermore, some heritage management units are not autho-

rized by law to ratify overseas exhibitions, and they regard such exhibitions as an opportunity to go abroad. Some Chinese exhibitors are careless and have too little oversight, to the embarrassment of their foreign hosts. These problems all reflect the lower level of daily work and lack of experience in dealing with foreign heritage and museum organizations and professionals.

Steps to Improve China's Participation in International Conservation Activities

The great achievements China has made in both its economy and its social development provide a wonderful opportunity, as never before, to develop international exchanges and collaborations on cultural heritage conservation. However, this remains a difficult task. I suggest the following steps to improve China's participation in the international conservation community.

- Make efforts to establish and maintain new relationships with cultural heritage administrations of countries with advanced conservation practice and enhance existing collaborative relationships.
- Make good use of intergovernmental collaborations to motivate and guide projects operated by Chinese nongovernmental organizations. Make full use of embassies and consulates to publicize the results and achievements of heritage conservation in China, while also requesting that the Chinese government provide sufficient support and materials.

- To enhance the role of personnel at each level of government, train foreign affairs personnel well in international relations and collaborations.
- Promote exchange and collaboration between scholars and between personnel in cultural heritage conservation administration and management. Enhance the legal system with regard to cultural heritage conservation, implement all rules, and abide by the law.
- Devise detailed strategies and plans to strengthen macroscale management.
- Make an effort to import advanced management ideas, as well as academic views and theories, and upgrade technology and equipment.
- Make staff training for international exchange and cooperation in cultural heritage conservation the top priority.

Conclusion

In the long term, training and improving the quality of staff are at the root of developing China's capabilities in cultural heritage conservation and management. International exchanges and cooperation are the most important way to achieve this goal, and the Dunhuang Academy is a successful example of this. A further example is the support that SACH provides the National Institute for the Conservation of Cultural Property in cooperating with the International Centre for the Study of the Preservation and Restoration of Cultural Property (ICCROM) to make training the top priority for Chinese conservation professionals.

Choices and Judgment: The Professional Conservator at the Interface

Sharon Cather

Abstract: *The China Principles define a clear structure for the conservation of heritage sites. Effective implementation of this process depends on the cooperation of professionals from various disciplines, reflecting prevailing international practice. Moreover, the China Principles are explicit in requiring that practitioners have specialist training and, for important aspects of the conservation process, that decision making be based on periodic review by a committee of experts. Clearly, this structure is designed to ensure a cautious and well-informed approach and relies fundamentally on the availability of qualified professionals. Although modern conservation demands expertise from a remarkable range of disciplines—from materials science to art history, from laser physics to cultural anthropology—the role of the conservator remains both central and extraordinarily challenging. This paper therefore focuses on what is expected of the professional conservator in the context of modern multidisciplinary conservation. It seems an opportune moment to do this given the important initiative of the Dunhuang Academy and Lanzhou University to provide education in wall painting conservation.*

Characterizing Current Conservation Practice

The second Silk Road conference provides an ideal opportunity for reviewing the evolution of approaches to the preservation of the cultural heritage and for examining the role of the conservator in that context. It is ideal for several reasons: the conference program exemplifies the extraordinary range of conservation activities and the professionals who undertake them; the balance of contributions—from man-

agement theory to materials testing—reflects increasingly accepted priorities for allocating resources; and, since the first Silk Road conference in 1993, the China Principles have been adopted and tangibly implemented at Mogao in the management plan and the cave 85 conservation program. There has been very significant progress.

How have approaches to conservation evolved in recent decades?¹ Broadly, the principal trends are toward preventive conservation and toward considering the entire site, ensemble, or collection (figs. 1, 2). These trends are led by ethics and by management theory. It is an approach that is more justifiable in terms of benefits and costs. There is also a trend toward minimal intervention, doing “as much as necessary . . . [but] as little as possible” (Australia ICOMOS 1999: preamble). This too is a consequence of applying newly formulated ethics more rigorously and of spreading scarce resources as effectively as possible: it is more ethical *and* more economical to do as little as possible.

Together with these trends to prevent decay, to conserve whole sites rather than individual objects, and to intervene minimally, there has been a redefinition of what conservation is about, what it is we are trying to preserve. This is expressed well in the China Principles: “the aim of conservation is to preserve the authenticity of all the elements of the entire heritage site and to retain for the future its historic information and all its values” (art. 2). Unpacking this compressed definition, we can see that values (significance) and authenticity assume a new prominence in conservation theory. Values, of course, change over time and with respect to various stakeholders. Recognition of that inevitable change should make us very cautious. Moreover,



FIGURE 1 Mogao, cave 260. Bodhisattvas in the N. Wei scheme of ca. 520/30. Photo © J. Paul Getty Trust

the obligation is emphatically to the future and rejects the implicit notion—so evident in past conservation approaches—that the current generation has the right to consume or to permanently alter the cultural heritage.

This evolved conservation approach is more economical (over the long term), more ethical, and more difficult. The economy of preventive conservation, including maintenance, is probably self-evident; the similar approach in health care—preventive medicine—provides a compelling model. However, the issue of whether it is more ethical to privilege the rights of future generations and to define values in an inclusive way is likely to be a matter of individual view. For this aspect, an obvious comparison is with environmental ethics, where positions tend to divide between assigning “extrinsic” and “intrinsic” values to the environment; that is, between an extrinsic, anthropocentric view in which values



FIGURE 2 View of part of the cliff face at Mogao. Conservation and management of the entire site are a priority of the Dunhuang Academy. Photo © S. Rickerby

are defined only by the potential for human exploitation and the alternate view that acknowledges intrinsic, inherent rights of the ecosphere, independent of humans.

And in what ways is this contemporary approach to preservation more difficult? Preventive conservation is far more challenging than remedial conservation. It requires an understanding of complex open systems that is sufficient to allow diagnosis, risk assessment, and prediction of the effects of preventive interventions.² This requires considerable knowledge of the original and added materials, of their current condition and their probable response (physical and chemical) to the changes we make to reduce decay. This is exceedingly difficult and makes one think immediately of the law of unintended consequences. While an apposite example has occurred at Mogao (Agnew 2003: 76–78), it is a phenomenon that is perhaps more familiar in the natural world. For example, the introduction of cane toads to Australia in 1935 for pest control has had catastrophic unintended consequences. In conservation, although research and investigation are now increasingly targeted at trying to increase our knowledge and skills aimed at understanding and predicting behavior of our complex systems, we have still barely scratched the surface.³

Compared with the resources spent on remedial interventions, funding for research is extremely scarce. This is in part because remedial interventions are often considered urgent (even though persuasive evidence may be lacking) and in part because research is a long-term investment, typically without immediately obvious benefit. Clearly, this bias in favor of urgency is not peculiar to conservation, and again the medical analogy is appropriate.

Preventive conservation, by definition, means intervening against the causes of the problems. In museums, where agents that cause deterioration—such as light, humidity, and pollution—can potentially be controlled, preventive conservation has made very considerable strides in recent decades. However, for site conservation, interventions relating to the causes of deterioration typically involve changing an aspect of the site and/or its use that is normally the responsibility of individuals who may only rarely—or indeed never—be directly involved in conservation. For example, preventive conservation may involve adjustments to the use of a building; it may be necessary for stakeholders to reduce or eliminate heating, even though they may be more interested in short-term comfort, *their* comfort, than in long-term preservation (Bläuer Böhm et al. 2001). Or, perhaps more familiar in the present context, it may be necessary to restrict access to part or all of a site and, in special cases, to make it indefinitely inaccessible.⁴

Terminology

Before proceeding with a discussion of the central role of the professional conservator in this conservation process, there are several basic notions that underpin the arguments in this paper and require definition. They are *professional*, *conservator*, *competency*, *interface*, and *judgment*. It seems sensible to be explicit about how they are being used in this specific context. For the first three, useful definitions are given below.⁵

- **Professional:** “a person (or work of such a person) with the following attributes: service orientation, making expertise available to others, based on a distinctive body of knowledge and skills underpinned by abilities and values, autonomy in performing work within defined boundaries, public recognition of the authority of the practitioner by virtue of working to ethical standards and being accountable.”
 - **Conservator:** “a professional who has the training, knowledge, skills, experience and understanding to act with the aim of preserving cultural heritage for the future.”
 - **Competency:** “specialist knowledge or skills required to perform a job function.”
- If, then, a conservator is a professional competent to preserve the cultural heritage, how do we define *interface* and *judgment* in our conservation context? The usual definition of *interface*, whether dealing with computers or with chemistry, is a “shared boundary” between two distinct things.⁶ Further, an interface can also be “the overlap where two theories or phenomena affect each other or have links with each other,”⁷ while in computing, an interface has an active role in allowing communication across this shared boundary. So, for the present discussion, my operational definitions are as follows:
- **Interface:** the shared boundary between the object to be conserved and the options for its conservation.
 - **Conservator:** the intermediary at that interface with the professional competency to facilitate communication about the object and its potential response among multidisciplinary professionals and stakeholders.
- Defining *judgment*—that is, professional judgment—is much more difficult. Looking to other disciplines for definitions, it was anticipated that there were likely to be similarities in issues of professional judgment in medical practice and in conservation. This is because they have a number of features in common: extremely limited resources in the face of high demand, a tension between competing claims for remedial versus preventive intervention, a perceived urgency to intervene, a reliance on symptoms (for conservation, this is condition; for medicine, it is how the patient “presents”), a very large number of variables that interact in a complex and often unpredictable manner, a need to interpret a wide range of complex data in relation to a specific patient, and a need to interface effectively among specialists and patients.
- A study by Eraut and du Boulay (2000) on medical professional judgment provides apposite comparisons for conservation. They note that a key goal of their research was to determine the nature of medical competence and judgment.

ment. Their study suggests that “good” professional medical judgment may involve

- discerning the key features of a patient’s problem in a more complex way;
- going beyond the guidelines;
- checking out expertise intuitively but rationally;
- making small approximate decisions and readjusting; and
- being prepared to do nothing.

Moreover, they found that the “most salient attributes of judgement . . . concerned making holistic and balanced decisions in situations of uncertainty and complexity.” Thus situations in which “good judgment” was required included, among others,

- decisions based on fuzzy logic in situations too complex to fully understand;
- ill-defined situations that are complex, diffuse, and muddled;
- high-risk situations;
- deciding between maximally and minimally invasive procedures (or doing neither); and
- balancing cost and quality.

There are remarkable similarities with current approaches to conservation, including the recognition that

- minimal or no intervention should always be an option;
- complex problems should be considered as holistically as possible; and
- an incremental and iterative approach is appropriate in complex situations.

It is this last point, applying an incremental and iterative approach to solving complex conservation problems, that I turn to next.

Addressing Complex Problems with an Incremental Approach and Iterative Method

A fundamental and unavoidable condition of conservation is the issue of scarce resources. All resources are scarce—funding, expertise, time, and, not least, access. The obvious consequence is that we need to allocate these resources

wisely. Moreover, we have a strong obligation to spend them ethically, so as to derive the greatest benefit. By applying an iterative approach to our complex problems, we allocate our resources more responsibly and arrive at more persuasive solutions.

An incremental approach recognizes that complex problems are best tackled in stages; it recognizes that diagnostic investigations and information gathering are, unfortunately, not as straightforward as we might hope. Basically, it aims to divide problem solving into separate components in order to address them in a sequence that facilitates and defines subsequent investigations. Such an approach is often problematic for managers because it presumes that decisions regarding resource allocation can likewise be made in stages, making budgeting more difficult. It also runs the very real risk that the required resources may not be available at later stages.⁸

An iterative method attempts to address a problem by finding *successive approximations* to obtain *more accurate* solutions. A simplistic example usefully demonstrates the method:

Think of a number between 1 and 100. A friend must guess the number in the minimum number of attempts, and all you can answer is “too high” or “too low.” Your friend will make guesses based on your answers that gradually get closer and closer to the correct number.

A sensible friend will halve the possibilities at each stage (e.g., 50, 75, . . .), arriving at the answer in a maximum of six to seven “guesses.” If we understand that each of our guesses represents a significant allocation of our limited resources, then it becomes clear that they should be well considered.

This method—aiming to find “successive approximations to obtain more accurate solutions”—recognizes that our problems are extremely complex and that we cannot expect to find precise, definitive answers. The iterative method is especially appropriate for conservation for the following reasons:

- It deals with a large number of variables.
- It is resource effective because it directs and focuses investigations.
- It addresses a multidisciplinary approach because data are regularly interpreted in relation to the original problems and hypotheses.

Iterative Method

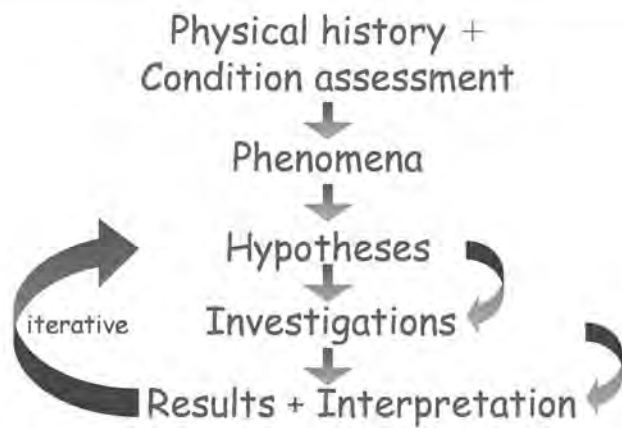

FIGURE 3 Iterative method: components and sequence.
© Courtauld Institute

- It requires revision of hypotheses based on the data collected.

The iterative method allows us to allocate our resources incrementally (fig. 3). It provides a structure for managing problem solving. It provides periodic checks both on the direction and on the success of investigations by examin-

ing their results. It engages the full range of professionals involved so that the problem solving can be kept on track. It also needs to be managed and directed, and in this the role of the professional conservator is central.

What Complexity?

All conservation deals with complex problems. So what is it that makes wall painting conservation so much more challenging?

- Wall paintings are completely and unavoidably physically dependent on their supporting structures; conserving a wall painting without ensuring the state of conservation of its support would be irresponsible.
- They are composed of layered porous materials, their porosity connecting them to one another, to their support, and to the ambient environment.
- They are part of an open physical system that very probably cannot be controlled, even minimally.
- They are very large, often hundreds of square meters.
- Finally, they are discontinuous, meaning that a large scheme may have areas that are missing or partly overlaid with later decoration or have been interrupted by architectural alterations.

FIGURE 4 Effects of habitation fires from White Russian soldiers interned in cave 260 in 1922, shown on splayed mosaiced images of the north and west walls surrounding the central pillar. Basemap images © Dunhuang Academy. Mosaicing and graphics © Courtauld Institute





FIGURE 5 Mogao, cave 260. An area protected by a Song period architectural addition (removed in the 20th century) is relatively unaltered. Original flesh tones and the organic colorant glaze on the red background contrast markedly with the same features in the unprotected area of the figure. Photo © Courtauld Institute

FIGURE 6 Mogao, cave 260. Exceptional preservation of the painting in figure 5 facilitates analysis by means of false-color infrared imaging. © Courtauld Institute; imaging by G. Verri

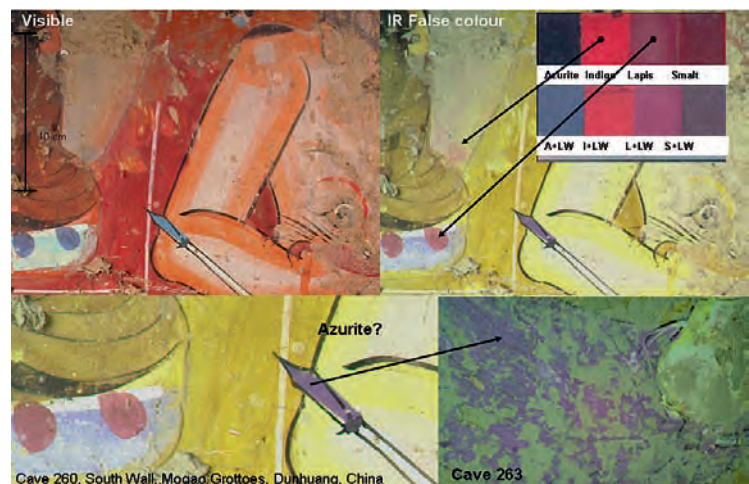

These factors combine to make wall paintings exceedingly heterogeneous; their technology and present condition vary enormously within the same painting (figs. 4–6). Because they are large and old, they are exposed to widely varying conditions from one area to another and over hundreds of years. Even at the Mogao Grottoes, where many painted caves have escaped radical alteration or major losses, the present condition of the wall paintings may change significantly from one area to the next. A good example of this is the fading of the organic colorants that were widely used in the original paintings.

This heterogeneity is four-dimensional. To the familiar two dimensions of the painting’s surface must be added the third dimension of the painting in depth, its stratigraphy. Wall paintings tend to have complex stratigraphies; they have not only multiple paint layers, metal foils, and attachments but also grounds, plaster layers, and the supporting structure. This stratigraphic complexity—and heterogeneity—is illustrated in figure 7, which shows all the components of the ninth-century Tang wall painting in cave 85 at the Mogao Grottoes.⁹ Finally, we need to add the fourth dimension, time. Wall paintings typically have a long history—a long *physical* history. Because they are part of the fabric, they are highly susceptible to change: deliberate alterations to the structure due to changes in fashion, use, patronage, or function; inadvertent structural damage due to natural catastrophes (e.g., earthquake, flooding); gradual “natural” decay due to use and the environment; and damage and deterioration from vandalism, iconoclasm, and, increasingly, tourism.

This heterogeneity vastly complicates all our efforts to understand the painting—that is, the present condition of

FIGURE 7 Four-dimensional heterogeneity in wall painting comprises the two dimensions of the topography, the third of the stratigraphy, and the fourth of time. Image © J. Paul Getty Trust. Graphics © Courtauld Institute

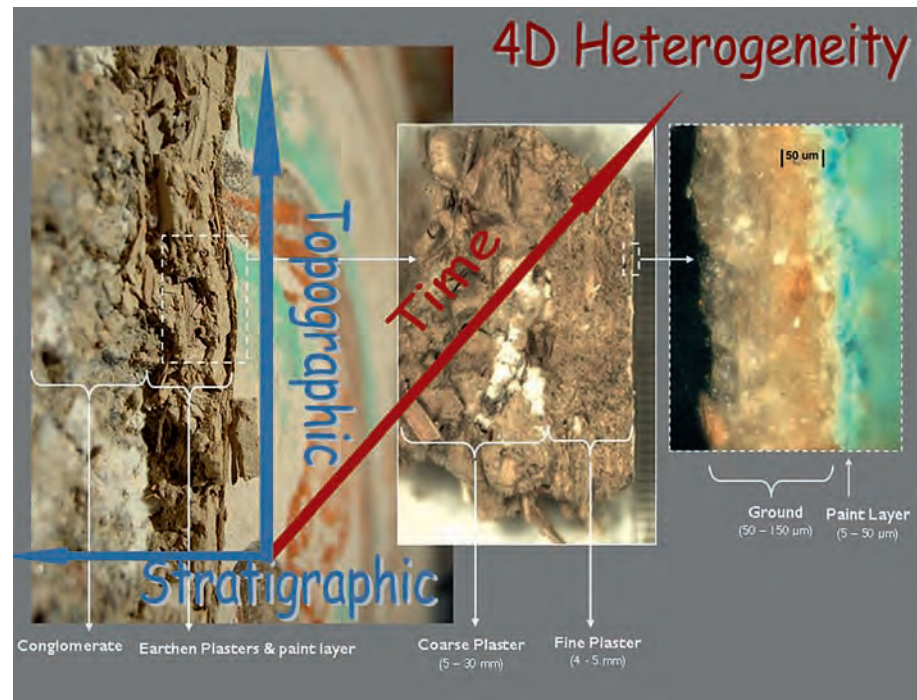

the original materials—because that condition varies literally from one point to the next. And it can vary significantly. It is well known that the distribution of contaminants, such as salts, is extremely heterogeneous. But we also need to remember that wall paintings have not only a complex stratigraphy but also a considerable surface area that has inevitably been exposed to differing environmental conditions and, more recently, different remedial treatments. When these differences are multiplied by time, the potential variation is daunting.

Choices and Judgment

To make informed decisions about conserving wall paintings, it is essential to try to understand both their original and their present—inevitably altered—condition. This “reconstruction” of the passage of the painting through time is termed assembling its physical history. The evidence on which the physical history is based may include historical documents—images (drawings or photographs), written records, and so on. Much more often, however, the evidence is circumstantial. For example, we may be able to *see* that there is a later architectural feature inserted, or blackening from fires used for habitation, or recent mechanical damage from tourists. More often, however, circumstantial evi-

dence is far more subtle and requires interpretation based on knowledge, experience, and comparable examples. Indeed, interpretation of circumstantial evidence must often remain a hypothesis until corroborating evidence is found.

Having assessed the present condition and assembled a physical history, it should then be possible to develop some hypotheses about the causes of any ongoing deterioration. The task for the professional conservator is to distinguish between past and present decay, to determine whether the causes of the problems are solely in the past or whether they are active and deterioration is continuing (Cather 2003: 64–66). Although this is a difficult process, it can and must be done.

Moreover, it needs to be undertaken iteratively, as outlined in the schema in figure 3, above. In this iterative process, determining the physical history and the present condition of the painting is the first essential step. As all experienced conservators know, understanding these two aspects is always interlinked: as the knowledge of the physical history accumulates, it informs an understanding of the present condition, while at the same time examination and recording of the condition will enrich an understanding of the physical history and focus lines of further investigation. That is why they are shown here as the combined starting point. This has implications for considering the risks inherent in dividing responsibilities. If it is decided by project

managers that these two activities will be undertaken by separate specialists—and this does occur—then there must also be the commitment, funding, and structure for regular, effective exchange and interpretation of information so that the crucial synergy in these two activities is not sacrificed. Perhaps even more important, it should be emphasized that only an experienced specialist conservator is competent to assess condition. Though it may be argued that the process of recording condition—usually computer-based graphic documentation—can benefit from specialist technical knowledge of hardware and software, it is still *what* is recorded and not *how* it is recorded that is of most importance. Our fascination with documentation technology is fading as the hard issues of cost, interoperability, communication, and long-term access are catching up with us.¹⁰

If it is assumed that we are undertaking this investigation process because there is a perceived problem (imminent risk of loss of original material), the next step is to define the manifestations—the phenomena—of the problems. As in the medical field, in conservation our problems are phenomenological. In medicine the patient presents with symptoms; it is also worth noting that in medicine the patient's (and family's) physical history is an important element to consider in both the diagnosis and the treatment. While defining and characterizing these condition phenomena are necessary, they are by no means straightforward. Broadly, conservators aim to do so without assigning causes to the condition they are recording. For example, a prudent conservator might define and record a condition phenomenon as “microflaking” but not “microflaking due to salts.” At this stage, the possibility that the microflaking is due to salts must remain a hypothesis to be investigated. It is all too easy to jump to wrong conclusions if causes are assigned too early in the investigation process. For this reason—and for several other very good reasons—the recent trend is to compile a visual glossary. Its function is to name, define, and describe the phenomenon and, importantly, to include a representative image (Wong 2003: 51–52).

Once the phenomena—symptoms—of our problems have been characterized in relation to the physical history and condition, the next step is to develop hypotheses about their causes. It is assumed that we have already established that the problems are *ongoing*; otherwise, diagnostic investigations to determine the causes and/or activation mechanisms are simply not necessary.¹¹ Developing these hypotheses requires considerable knowledge and experience. It is especially difficult because the same phenomenon may

result from any of several different causes, and conversely, the same cause may result in a variety of different phenomena. Returning to the medical analogy, if a patient presents with a fever it is quite obvious that there can be a wide range of possible causes.

Having established potential hypotheses, in order to proceed with the investigations designed to test them it is necessary to establish a priority and a sequence, to determine which of the phenomena is more critical for the preservation of the wall painting, which of the competing hypotheses is most likely, and therefore what is the most effective allocation of scarce resources. An example may help to clarify this. Moisture is a common cause of the deterioration of wall paintings. But moisture may be either liquid or vapor, and the processes for determining which is the source of the problem are very different. They differ not only in method but also in resource allocation, since investigating water vapor typically consumes far more time and money. In this case, condition is an extraordinarily powerful tool for deciding which—liquid or vapor—is more likely to be a problem and should therefore be investigated, and it can also provide the basis for determining appropriate sampling strategies (Cather 2003: 72–74). The professional wall painting conservator has a central role in this process of determining hypotheses, then prioritizing and sequencing investigations, which often involves a range of related disciplines and experts.

The iterative method then continues with investigations to test the hypotheses. What is significant here is that it is the hypotheses that are being tested. There are no standard investigations to undertake; there are no boxes to check in a list of ideal investigations. If we accept that our resources are scarce, then this clear targeted allocation of them is the most effective and ethical approach.

Finally, the results of these investigations must be interpreted in relation to the original hypotheses. This should be done as soon as possible and considered by all the relevant professionals. All too often results of such specialist investigations are set aside as data for a final report, whereas their real value is as an integral part of the problem-solving process. It is essential that they be interpreted and disseminated so that if the hypothesis is not supported by the results of the investigations, then it can be modified, alternative investigations can be determined, or it can simply be rejected. This timely feedback is a crucial aspect of the iterative method and presumes that specialists communicate effectively.

It becomes fairly clear that this approach to conservation—in which it is considered important to determine

the causes of the ongoing problems so that preventive or passive interventions can be undertaken—is a genuine problem for managers. However experienced and knowledgeable the experts are, it is simply not possible to cost this process at the outset. It is possible to make estimates, but they are inevitably based on presumptions that may well prove wrong. Nonetheless, most conservators are coerced into doing this. Clearly, this is a much greater issue than can be aired in the present context. However, it remains the responsibility of the conservator to communicate this uncertainty.

Choices and judgment obviously extend to remedial interventions. Indeed, they are much better understood in that context, hence the emphasis here on the less familiar diagnostic phases of the overall process. In remedial treatments the role of the professional conservator is more broadly recognized; here it is defined as acting as the intermediary at the interface, with the professional competency to facilitate communication with multidisciplinary professionals and stakeholders about the object and its potential response.

The Multidisciplinary Conservation Process

Conservation is global in much the same way that science is global. In conservation, the tools, the methods, and the approaches are—or are quickly becoming—the same throughout the world. Certainly that is the expectation of the international community, as reflected in charters and by professional bodies. But conservation education is not. It is based on local—usually national but also regional—educational structures and on the market, unfortunately driven more by prospective students than by informed stakeholders. This results in a chaotic provision of “training” at all levels and of varying lengths, from a few weeks to several years. It means that the expectation of professionalism in conservation is hampered by erratic educational provision.¹²

This situation is complicated by widely varying infrastructures for the conservation of cultural heritage. However, a relatively recent improvement is the development of the theory and practice of site management (Sullivan, this volume). Managing cultural heritage is emerging as a new discipline and is still in its formative stages. Conservators and managers play complementary roles in preserving cultural heritage, and it is important that they understand not only the processes of conservation but also their respective roles and competencies within that process. As a multidisciplinary endeavor, conservation relies on effective teamwork and communication.

Managers, by definition, have a pivotal role in site conservation. Competent conservators recognize this. Moreover, site management issues have become an essential component of the conservation curriculum. What is needed now is the mutual recognition of the complexities and challenges of each role and the ways in which these professionals must interact. If the conservator is at the interface of the object and the options for preserving it, then the manager is the professional responsible for overseeing the quality of the process outlined above and for implementing the informed decisions. One of those responsibilities is to ensure that physical conservation is the responsibility of competent professional conservators. All too often “conservators” without qualifications and with wholly inappropriate experience are employed instead. A parallel issue is the substitution of technicians for conservators. While it may be argued that in some specific contexts technicians do have a valid role, it is the manager’s responsibility to ensure that the activities of technicians are limited to clear and explicitly assessed competencies. Moreover, they must also ensure that the conservation decisions are made by qualified professionals. This does not mean that they must have a detailed knowledge of conservation, but it does mean that they need to understand the process and to recognize the need for qualified professionals to undertake this complex, multidisciplinary endeavor. Only in this way can we tackle the massive complexities of a site such as Mogao. Only by working together, recognizing and fulfilling our mutually dependent roles, can we have some confidence that the decisions we make on behalf of future generations are genuinely “as much as necessary . . . [but] as little as possible.”

Acknowledgments

It is a pleasure to be able to acknowledge those who have played an important role in the formulation of the views expressed here. My colleagues David Park, Heinz Leitner, Christine Bläuer Böhm, and Mauro Matteini have provided constant inspiration over the years through our collaboration and by their example. However, as a teacher, I owe the largest debt to my students. Challenging, demanding, highly competent, and committed, they have been a constant spur to rethink from first principles. Much of what is presented here is the result of their insights. Although it is not possible to thank them all individually, it is possible to thank those who are here at the Second Silk Road conference, many as contributors: Stephen Rickerby, Francesca Piqué, Lisa Shekede,

Lorinda Wong, Stephen Paine, Sophie Stewart, Rachel Burch, Robert Gowing, Stephanie Bogin, Emily Howe, Jaana Loring, Charlotte Martin de Fonjaudran, Austin Nevin, and Sibylla Tringham.

Notes

- 1 While recognizing the importance of the intangible cultural heritage, the current discussion focuses on the tangible.
- 2 In a strict sense, the term *open system* refers to thermodynamics (and, more recently, computing). “The definition of an open system assumes that there are supplies of energy that cannot be depleted; in practice, this energy is supplied from some source in the surrounding environment, which can be treated as infinite for the purposes of study” (http://en.wikipedia.org/wiki/Open_system_%28system_theory%29). For our purposes, we can accept the idea of external energy—in our case, the environment—and add the notion that in many, or even most, cases the potential for controlling that energy is small or nonexistent.
- 3 For example, the lack of postintervention assessment, whether of preventive or remedial interventions, is a major stumbling block. It is very rarely funded for site conservation. Nor do we have adequately developed methods to undertake it successfully; this would certainly require planning and a high level of recording at the time of the intervention.
- 4 In the context of site conservation, a significant example is the reburial of the Laetoli hominid trackway by the Getty Conservation Institute (Agnew and Demas 1998). An important precedent in a museum context is the case of the *Très Riches Heures*; this exceedingly important illuminated manuscript was put into permanent dark storage in 1986 by the Musée Condé, Chantilly (Camille 1990). The 2008 IIC Congress addressed the implied antagonism between conservation and access, including in a paper by Andrew Thorn titled “Access Denied” (2008).
- 5 Definitions are typically specific to their context. A wonderful example is this definition of *competency*: “The ability of prokaryotes to stably incorporate exogenous DNA fragments from the environment into their genomes” (www.nature.com/nrg/journal/v4/n2/glossary/nrg1000_glossary.html). The definitions used for *professional*, *conservator*, and *competency* were selected on the basis of their appropriateness for the present context and are from, respectively, Engineering Council of South Africa, Standards and Procedures System (www.ee.wits.ac.za/~ecsa/gen/g-04.htm#Professional); ECCO Professional Guidelines I—The Profession: 2002; and www.environment.gov.au/settlements/industry/finance/glossary.html.
- 6 For computing, see www.nps.gov/gis/gps/glossary.htm; and for chemistry, wordnet.princeton.edu/perl/webwn.

- 7 wordnet.princeton.edu/perl/webwn.
- 8 Similar issues arise with conservation interventions. Managers want hard costings at the outset, even though we all know that there are likely to be unforeseen—indeed unforeseeable—problems that will arise. Although this is a significant problem for site conservation, it is rarely raised.
- 9 See relevant papers on the cave 85 project, this volume.
- 10 ICCROM’s publication of its 1999 research seminar on graphic documentation for wall painting conservation (Schmid 2000) remains the best general source for both technical options and informed views. For a significant contribution to the critical assessment of documentation generally, see Wong et al., this volume.
- 11 For clarification of the differences between causes and activation mechanisms and, therefore, between preventive and passive conservation interventions, see Cather 2003: 69–70.
- 12 For a discussion of conservation education and the challenges it poses, see Cather 2001.

References

- Agnew, N. 2003. Sins of omission: Diagnosis, risk assessment and decision. Lessons from three sites. In *Conserving the Painted Past: Post-Prints of a Conference Organized by English Heritage, London, 2–4 December 1999*, ed. R.Gowing and A. Heritage, 75–84. London: English Heritage.
- Agnew, N., and M. Demas. 1998. Preserving the Laetoli footprints. *Scientific American*, September 1998, 44–55.
- , eds. 2004. *Principles for the Conservation of Heritage Sites in China = Zhongguo wen wu gu ji bao hu zhun ze [Chinese-language document] issued by China ICOMOS; Approved by the State Administration of Cultural Heritage*. Los Angeles: Getty Conservation Institute.
- Australia ICOMOS. 1999. Burra Charter. www.icomos.org/australia/burra.html.
- Bläuer Böhm, C., K. Zehnder, H. Domeisen, and A. Arnold. 2001. Climate control for the passive conservation of the Romanesque painted wooden ceiling in the church of Zillis (Switzerland). *Studies in Conservation* 46 (4): 251–68.
- Camille, M. 1990. *The Très Riches Heures: An illuminated manuscript in the age of mechanical reproduction*. *Critical Inquiry* 17: 72–107.
- Cather, S. 2001. The dilemma of conservation education. *Conservation: Getty Conservation Institute Newsletter* 15 (1): 9–12. http://getty.edu/conservation/publications/newsletters/15_1/feature1_3.html.
- . 2003. Assessing causes and mechanisms of detrimental change to wall paintings. In *Conserving the Painted Past: Post-Prints of a Conference Organized by English Heritage, London, 2–4 December*

- 1999, ed. R. Gowing and A. Heritage, 64–74. London: English Heritage.
- Eraut, M., and B. du Boulay. 2000. Developing the attributes of medical professional judgement and competence. University of Sussex. www.cogs.susx.ac.uk/users/bend/doh/reporthtml.pdf.
- Schmid, W., ed. 2000. *GraDoc: Graphic Documentation Systems in Mural Painting Conservation, Research Seminar, Rome, 16–20 November 1999*. Rome: ICCROM.
- Thorn, A. 2008. Access denied: Restricted access to indigenous cultural sites. In *Contributions to the 2008 IIC Congress*, ed. D. Saunders, J. Townsend, and S. Woodcock. London: IIC.
- Wong, L. 2003. Documentation: Objectives, levels and the recording process. In *Conserving the Painted Past: Post-Prints of a Conference Organized by English Heritage, London, 2–4 December 1999*, ed. R. Gowing and A. Heritage, 46–54. London: English Heritage.

PART ONE

International Collaboration



UNESCO Support for Cultural Heritage Conservation in China

Du Xiaofan

Translated by Naomi Hellmann

Abstract: UNESCO is an intergovernmental agency that functions as a catalyst for international cooperation under the principles of excellence and innovation in alliance and partnership. In fulfilling its leadership role, UNESCO seeks to ensure a responsible framework for the implementation of multilateral and bilateral projects at the regional and national levels. Four UNESCO-supported conservation projects in China are described in this paper: the ancient ruins of Jiaohe, Hanyuan Hall of Daming Palace, Kumtura Caves of the Thousand Buddhas, and Longmen Grottoes. All four projects were supported by the UNESCO/Japan Trust Fund for the Preservation of World Cultural Heritage, which provided generous technical, scientific, and material assistance from 2001 through 2007. The goal of these projects is to strengthen collaboration among research scientists, academic scholars, and government authorities from specialized Chinese and Japanese establishments; build local capacity in cultural heritage conservation; and achieve a well-managed site to ensure its long-term existence. The projects emphasize the importance of interdisciplinary education and training in cultural heritage conservation and the value of mutual collaboration and communication.

The United Nations Educational, Scientific and Cultural Organization (UNESCO) is a specialized agency of the United Nations whose mission is to create the conditions for genuine dialogue among nations based on respect for shared values and the dignity of each civilization and culture. The constitution of UNESCO was established in November 1945, and one month later its headquarters were set up in Paris. As of 2006, the organization comprised 191 Member States and six Associate Members.

Until the 1960s, the protection of cultural heritage within national boundaries was considered a domestic affair and the responsibility of the state. This changed after Egypt and Sudan submitted an urgent appeal to UNESCO in 1959 for help salvaging endangered monumental sites in Nubia. The construction of the Aswan Dam on the Nile threatened to submerge Nubian monuments from Abu Simbel to Philae. On March 8, 1960, Vittorino Veronese, then director-general of UNESCO, issued a call for action among all national governments, organizations, public and private funding, and individual patrons to provide technical and financial assistance for the safeguarding of the Nubian monuments.

The UNESCO effort to rescue the Abu Simbel temple from the dam on the Nile began in 1962 and lasted eighteen years. Encouraged by the success of this initiative, many countries turned to UNESCO for support from the international community to preserve national archaeological treasures. The actions undertaken to salvage the monuments of Nubia, therefore, presented a new direction and focus for UNESCO, as well as the international community, in the conservation and protection of historical monuments as part of the world's common cultural heritage. In 1972 the World Heritage Convention was passed at the General Session of UNESCO, providing the first permanent legal, administrative, and financial framework for international cooperation in safeguarding the cultural and natural heritage of humanity. The convention introduced World Heritage as a concept that transcends political and regional boundaries. It aims to raise awareness among the people of a nation that their cultural heritage is irreplaceable and that responsibility for its protection ultimately lies in their hands.

However, the convention also recognizes that it is the task of the international community to support the protection of world heritage and to assist those countries that lack the resources to properly protect their heritage. Although it is beyond the means of the World Heritage Committee to respond to every application for technical cooperation, organized funding on the basis of voluntary contributions from Member States is available through UNESCO. One important donor is the government of Japan, which established the Japanese Funds-in-Trust for the Preservation of World Cultural Heritage in 1989. As of 2004, the Japan Trust Fund had assisted in the protection of more than thirty-one sites in twenty-four countries, mainly in Asia.

UNESCO's Role in Cultural Heritage Conservation in China

Since economic reforms were first implemented in the early 1980s, China has adopted many policies that focus on investing in urban infrastructure and human resources to nurture the growth of cities, industry, agricultural cooperatives, and foreign exchange. Such rapid development has created significant external costs, including urban growth, environmental degradation, and unrestricted tourism, that severely threaten the future of China's ancient heritage.

Recognizing the magnitude of the problem, the Chinese government has focused on implementing effective legal, organizational, and educational measures. Beginning in the mid-1980s, the government collaborated with UNESCO to increase international cooperation and exchange and to help improve cultural heritage protection in China. Several conferences were organized, such as the Asia Regional Conference on the Technical Preservation of Cultural Relics held in Beijing in 1986. This conference became a focal point for conservationists throughout Asia.

This type of cooperation expanded in the 1990s with increased support from UNESCO and from the State Administration for Cultural Heritage of China (SACH). From 1990 to 1995, training seminars were held on mural conservation, traditional architecture conservation theory, grotto conservation, and wooden architecture conservation techniques. These seminars capitalized on national and international expertise to introduce advanced technology and new ideas in cultural heritage conservation to practitioners in China.

In 1991 UNESCO used special funds from the International Committee for the Protection of the Great

Wall and Venice to help China repair the west side of the Mutianyu section of the Great Wall. In July of the same year, Mount Huang (Huangshan), a scenic landmark situated in Anhui province, received emergency assistance from the World Heritage Fund to restore traditional structures damaged by heavy flooding. In 1994 preservation of the Peking Man Site at Zhoukoudian also received emergency funding. Other projects supported by UNESCO include the installation of a security system at the museum of the Qing Imperial Mountain Resort and its outlying temples at Chengde, Hebei province; organization of a training course in 1987 on the management of world heritage in China; an emergency rehabilitation and restoration plan of the Old Town of Lijiang in Yunnan undertaken in 1996–97 in the aftermath of a large earthquake; and the preservation of traditional streets in Suzhou, Lijiang, Beijing, and Lhasa.

In December 1985 China ratified the World Heritage Convention. As of 2006, thirty-three designated cultural, natural, and mixed properties from China have been inscribed on the World Heritage List.

The UNESCO Office Beijing

The UNESCO Office Beijing was created in 1984 as the UNESCO office in China for science and technology. Since then, the office has gradually expanded its activities and territory covering northeast Asia to also include sectors for culture, education, the social sciences, and communication and information. In January 2002 the UNESCO Office Beijing became the cluster office for the East Asian region, which includes the Democratic People's Republic of Korea (DPRK), Japan, Mongolia, the People's Republic of China, and the Republic of Korea (ROK). The main purposes of the UNESCO Office Beijing are (1) to implement UNESCO programs with consideration of the East Asian region's interests and circumstances and (2) to articulate the current and future needs of the East Asian Member States and to facilitate the incorporation of these needs within the framework of UNESCO programs.

The UNESCO Office Beijing works in close collaboration with local governments and with organizations affiliated with the government to strengthen cultural heritage protection in northeast Asia, where many of the world's ancient civilizations originated. In addition to UNESCO's regular programs, the Chinese government receives assistance through the UNESCO Office Beijing in applying for extrabudgetary programming.

UNESCO Projects in China

Under the UNESCO/Japan Funds-in-Trust for the Preservation of World Cultural Heritage, China received assistance for several important conservation projects: the ancient ruins of Jiaohe, Hanyuan Hall of Daming Palace, Kumtura Caves of the Thousand Buddhas, and Longmen Grottoes. The Jiaohe and Hanyuan Hall projects were completed in 1996 and 2003, respectively. Work on the Longmen Grottoes and the Kumtura Caves is scheduled for completion in 2008. Each project is administered under the executive agency of UNESCO. The managing agency is SACH, which authorizes the work of a local implementing agency such as the Longmen Grottoes Research Institute or the Xinjiang Bureau of Cultural Relics. The collaboration engages the work of Chinese and Japanese experts, who are affiliated with various universities and research institutes in China and Japan.

Conservation of the Ancient Ruins of Jiaohe

The Conservation of the Ancient Ruins of Jiaohe was the first UNESCO/Japan Funds-in-Trust project to be implemented in China. Historical records show that Jiaohe was the earliest political, economic, and cultural center of the Turpan basin in Xinjiang Uyghur Autonomous Region more than two thousand years ago. Beginning in the Han dynasty (206 B.C.E.–220 C.E.), Jiaohe played an important role in facilitating cultural exchange between China and the West as one of the major central Asian trading capitals of the Silk Road. Today, Jiaohe is a rare example of a well-preserved ancient city with earthen architectural ruins that cover 22 hectares of the 35-hectare site. The existing structures are mostly remnants from the third to sixth century C.E.

In 1993 the UNESCO Office Beijing signed a three-year contract with SACH for a \$1 million (USD) project to protect Jiaohe (fig. 1). Several objectives were established, including



FIGURE 1 Ancient city of Jiaohe, Xinjiang Uyghur Autonomous Region.



FIGURE 2 Visitor path at Jiaohe.

the detailed compilation of research, experimental analysis, archaeological excavation, atmospheric monitoring, area mapping, partial site restoration, and construction of a flood control measure and visitor path (fig. 2), as well as a master plan for the protection of Jiaohe. The project, which was successfully completed in 1996, provided a solid foundation for the future of Jiaohe and imparted valuable experience in the protection of other Chinese heritage sites.

Conservation of Hanyuan Hall of Daming Palace

Located northeast of Xi'an in Shaanxi province, Daming Palace existed as the largest Tang dynasty (618–907 C.E.) imperial palace in the city of Chang'an for over two centuries and was the site of many stately occasions. Important diplomatic exchanges were held in Hanyuan Hall, the main hall of the palace, before it was destroyed in a fire in 886. Today, the ruins of Daming Palace are part of the cultural legacy of the world.

What remains of Hanyuan Hall is its earthen foundation, an elevated platform measuring approximately 15 meters high, 200 meters wide, and 100 meters long that serves to commemorate the imposing splendor of Tang dynasty architecture. The conservation initiative undertaken by UNESCO, China, and Japan ensures that the foundation of Hanyuan Hall survives as an on-site museum to educate the public about the history of Sino-Japanese diplomatic exchange.

Preventive conservation measures began in 1993 and led to the adoption of the formal Plan of Action by the UNESCO Office Beijing and SACH on July 24, 1995. The two-phase conservation efforts lasted almost ten years, with most of the work concluding in late March 2003. Based on an extensive analysis of archaeological finds and scholarly documentation, the work included protecting the Hanyuan Hall foundation with an added layer of brick. In addition, Tang dynasty building materials and construction techniques were replicated as closely as possible in the restoration of the base of two pavilions, two passageways, and the site of Tang brick kilns that were part of the Hanyuan Hall complex. These structures have been protected, are accessible to the public, and constitute an important part of the on-site museum.

Conservation of the Kumtura Caves of the Thousand Buddhas

The Kumtura Caves of the Thousand Buddhas are situated 25 kilometers west of Kuqa (Kucha) in the Xinjiang Uyghur Autonomous Region (fig. 3). This important site along the



FIGURE 3 Kumtura Thousand Buddha Caves along the Muzat River, Xinjiang Uyghur Autonomous Region.

ancient Silk Road was created by the Quici, Turk, Han, Huigu, and Turpan peoples over a period of six hundred years, from the fifth through the eleventh century C.E. The oldest of the 112 remaining cave temples dates to more than fifteen hundred years ago. The Kumtura caves contain a wealth of unique art and architecture, including Quici, Han, and Huigu inscriptions, which provide a firsthand source of information on the history of central Asia. The caves have attracted the attention of scholars from China and abroad and are of great international significance for their blending of Eastern and Western cultural traditions, as well as their exceptional historic, scientific, and artistic value.

The Kumtura caves were severely damaged during the spread of Islam through central Asia in the ninth century. Nomads and visitors using the caves as temporary living quarters after the site was abandoned also caused significant destruction. In the 1970s a dam constructed by the Dongfang Hong Hydropower Plant in the lower reaches of the Muzat River running in front of the caves raised the level of the river substantially, causing further decay to the grottoes and mural paintings. Today, the caves continue to face the threat of earthquakes, flooding, erosion, excessive moisture, and cracks in the conglomerate rock. **Unfortunately, these problems have yet to be brought under effective control, and there is a realistic chance that the Kumtura caves will disappear entirely.**

A professional team was first sent by UNESCO in 1999 to inspect the Kumtura caves. A second mission undertaken in April 2000 included UNESCO, SACH, and Japanese administrators and specialists. At a subsequent meeting in Urumqi, the capital of Xinjiang province, it was decided that the UNESCO/Japan Trust Fund for the Preservation of World Cultural Heritage would allocate funding to salvage

the Kumtura caves as a cultural treasure of the Silk Road. On June 1, 2001, UNESCO and the Xinjiang government organized another meeting to assess the effects of the Dongfang Hong Hydropower Plant dam on the Kumtura caves. On-site research was conducted by Chinese and Japanese specialists from August 24 to September 2, 2001, which resulted in a plan of operations that went into effect on September 16, 2002.

Kumtura faces a number of challenges as a cultural heritage conservation project, including the area's extreme weather conditions and remote location and the complexity and severity of the damage. Aligning the various interests and demands of stakeholders under difficult circumstances was essential to ensuring effective cooperation for the long-term conservation of the site.

The immediate goals for the conservation and restoration of the Kumtura caves include undertaking urgent protective measures to prevent splitting and falling rock, further deterioration **to the mural paintings, and flood damage.** Emergency restoration work to salvage major caves was carried out from 2001 to 2004. The long-term goals of the Kumtura project include implementing sustainable management and conservation programs, improving the surrounding environment, introducing better provisions and facilities for tourists, and making the site more accessible to the general public and for specialized research.

During the first phase of the project, 2001–4, preventive conservation measures were adopted based on geological, meteorological, archaeological, and other scientific research conducted to assess the various causes of damage at the Kumtura caves and in the surrounding area (figs. 4, 5). Remedial conservation measures are planned for the second phase of work, 2005–8, and will be based on a detailed analysis of the climate, physical environment, and composition of the mural paintings. Measures will focus on strengthening the conglomerate rock, treating the peeling and fading mural paintings, and controlling excessive moisture content in the caves.

Phase 2 of the project will specifically address protecting the murals and reinforcing the fractured and shifting rock body of the five connecting caves, and reinforcing hazardous rock around caves 79 and 80. This phase will also address the hazardous rock and flood erosion that threatens the murals in caves 1 and 2. These two isolated circular dome caves were discovered in the late 1970s. Because of their secluded location, they have been protected from the kind of damage caused in the other caves by past occupants.

This conservation project was selected because it represents a characteristic heritage site that poses key technical



FIGURE 4 Project specialists assess damage to Kumtura mural paintings.



FIGURE 5 Project specialists assess rock damage inside a Kumtura cave.

questions and challenges. The experience gained here serves as a valuable model for the future conservation of Kumtura and other comparable sites.

Conservation of the Longmen Grottoes

The Longmen Grottoes, located 13 kilometers south of Luoyang in Henan province, were created over a four-hundred-year period. Beginning in 494 C.E., more than 2,300 caves and small niches were carved into the Xiang and Longmen limestone cliffs along the banks of the Yi River (figs. 6, 7). The site, which includes 40 stupas and more than 3,600 stelae and 10,000 statues, was inscribed by UNESCO as a World Heritage Site in 2000. Over the past fifteen hundred

years, the Longmen Grottoes have suffered extensive damage caused by both humans and nature. Conservation work undertaken by the Chinese government began at the site in 1953 with the preliminary establishment of an administrative office. Since then, work has progressed in two stages. (1) Prior to 1971, conservation focused on preventing man-made damage to the site. Beginning in 1965, measures to enhance scientific conservation included training technical staff, constructing laboratories for testing, installing a meteorological station, and conducting a geological survey of the area. (2) From 1971 to 1985, emergency restoration work was undertaken based on an analysis of threats, atmospheric data, mapping, and seismic activity. A comprehensive



FIGURE 6 Caves and niches of the Longmen Grottoes along the west bank of the Yi River in Henan province.



FIGURE 7 Fengxian temple, the largest cave at the Longmen Grottoes.

management plan was finalized in 1987, and the Longmen Grottoes Research Institute was founded in 1990.

Despite early studies and conservation work, the Longmen Grottoes continue to be affected by water seeping through cracks in the rock body, erosion and damage to the exterior rock body, growth of microorganisms and lichen, deposits of soot and grime inside the caves, and other damaging factors. In response, an international cooperation initiative to protect the Longmen Grottoes began in October 2001 with support from UNESCO/Japan Funds-in-Trust.

During phase 1, from 2001 through 2005, the major factors threatening the Longmen Grottoes and their causes were determined. Work focused on research, including topographical mapping, geological surveying, and environmental monitoring inside the caves, as well as assessing erosion, water damage, and deterioration from exposure to pollutants in the environment. Three caves—Qianxi, Huangpugong, and Lu—were selected for pilot conservation studies. Computerized equipment was installed in these caves to monitor changes in the macro- and microclimate, measure the temperature inside the rock body throughout the year, and record the distribution of cracks in the rock body and shifts in their positioning. Condensation was monitored in Qianxi and Huangpugong caves.

This effort established a solid foundation for the work in phase 2, which began in May 2005. This phase, which continues through 2008, involves the actual conservation of the three pilot caves. The immediate goals are to improve the environment of the caves, install appropriate environmental monitoring equipment, and adopt a standard system of maintenance. The project's long-term goals include building sustainable management and conservation practices that maximize on the knowledge shared and experience gained throughout the process of preservation.

Lessons Learned

UNESCO advocates that responsibility for the protection of cultural heritage should ultimately be in the hands of the nation where the heritage is located. International efforts to protect that heritage should emphasize respect for the country's culture, traditions, and ideas. A balanced exchange that capitalizes on international expertise while recognizing the capacity and interests of the host country is necessary.

A number of lessons were learned from the four international conservation projects described in this paper.

1. Using its administrative capacity to coordinate and organize, the UNESCO Office Beijing was able to effectively oversee the management and implementation of the projects in a way that facilitated communication and fostered agreement between the international specialists and the national project members. Achieving a balance of interests and mutual accord among stakeholders is often one of the biggest obstacles encountered on projects involving international cooperation and is necessary to ensure their sustainable operation.
2. Communication and understanding among all project members, including specialists, management, and other personnel, are key to a project's success. This includes exchanging ideas about cultural heritage, national values, work technique, and the materials and technology used in conservation, which vary significantly between individuals and nations.
3. Learning from and engaging local expertise play an important role in cultural heritage conservation. This was especially true for building a sustainable protection strategy for the Longmen Grottoes and the Kumtura caves. In guiding and encouraging existing conservation efforts, project staff were able to strengthen the professional capacity of local personnel and foster an independent body of management in Xi'an, in the Xinjiang Uyghur Autonomous Region, and at the Longmen Grottoes Research Institute.
4. The most advanced technology or a meticulous project design must often be compromised for more practical measures of conservation. This means taking into account the local climate, economic situation, and human resources in the creation of an operational work plan. Equipment should be selected based on function, as well as the skill level of local employees and the local environmental conditions.
5. Conservation is more than just a technical matter. The growing needs of the local population and the local economy cannot be overlooked in the interest of heritage conservation. Instead, a holistic approach is recommended, integrating the local heritage into the larger environment and adjusting to the current contending social norms, political interests, and other external forces.

International Cooperation for the Protection of China's Cultural Heritage

Huang Kezhong

Abstract: *Diverse international collaborations have had a positive effect on China's efforts to preserve its cultural heritage. A number of conservation specialists have been trained and assistance has been provided in the form of technology, funding, and equipment. Successful international collaboration depends on a number of factors: a long-term strategic plan for cooperation, project leaders who can communicate effectively in a spirit of mutual trust, younger project members eager to learn and experiment, support and guarantees from the authorities in charge, and adoption of useful concepts and technologies. This paper reviews China's efforts to protect its cultural heritage through international collaborations and identifies the factors that have led to the stable, eighteen-year collaboration between the Dunhuang Academy and the Getty Conservation Institute.*

The significance and beauty of China's cultural heritage have inspired the Chinese government and conservation specialists to create effective and efficient theories and methodologies for its protection, but these are far from perfect. Consequently, China has sought assistance from other countries. Through international cooperation, the more advanced expertise developed by other countries for the protection and management of their cultural relics and sites are complementing the Chinese methodology.

Since the implementation of reforms and policies in China that opened the country to the outside world, cooperative programs have greatly benefited China. China's programs with other governments, UNESCO, community associations, and foundations, as well as with individuals, have yielded considerable benefits. These programs have included joint research projects, academic conferences,

management of archaeological sites, staff training, and the building of infrastructure and research facilities. All such efforts have helped to convey to the outside world China's aspirations to protect its cultural heritage.

The China Principles

China's move toward international cooperation to protect its cultural heritage is defined by the *Principles for the Conservation of Heritage Sites in China* (Agnew and Demas 2004). This document, hereafter referred to as the China Principles, contains national guidelines for the conservation and management of cultural heritage sites in China. Drafting of the document was a joint effort involving three parties: China's State Administration of Cultural Heritage (SACH), the Getty Conservation Institute (GCI) in the United States, and the Australian Heritage Commission. The three parties began drafting the China Principles in 1997. In support of this effort, field studies were conducted in all three countries, and numerous working sessions were held to discuss the results of the field research. These activities made it possible to constructively revise the draft guidelines.

At the same time, the collaborative activities also provided an opportunity for countries to understand one another's different approaches to conservation. For example, with regard to the restoration of ancient buildings, some foreign experts suggested that China had done excessive refurbishing, which could damage the original material. Chinese experts, on the other hand, suggested that, as most of the ancient buildings in China were made of wood, the damage to beams, pillars, and so on had to be restored or refinished so as to avoid total collapse. To maintain the original

appearance, then, efforts should be made to maximize the similarity of the coloring, patterning, and painting. All of this is a consequence of the nature of wood, which is the mainstay of building materials in China. This kind of restoration is not, according to Chinese experts, contrary to the principle of accurately maintaining the original appearance and authenticity of the heritage architecture.

Language did not constitute a significant hindrance during discussions of the field research, and even when discussing complicated and abstract topics, Chinese scholars and their English-speaking American and Australian counterparts succeeded in reaching consensus on the many issues before them.

Many of the principles embodied in Australia's Burra Charter (Australia ICOMOS 2000), which provides guidance for the conservation and management of places of cultural significance, were incorporated in the revisions of the China Principles. For example, article 11 of the China Principles, on assessing the value of cultural heritage and the procedure for assessing significance, originates from the Burra Charter.

The China Principles are fully within the scope of the relevant laws of China. They are based on the idea that protection is the main goal and, following Chinese law, that restoration of heritage on the verge of extinction is of top priority, that reasonable use is beneficial to contemporary society, and that effective management guarantees all of these. The China Principles are, therefore, a set of academic and technical guidelines regulated by China's laws; the document states, as does Chinese law, that the contemporary values of cultural relics are threefold: historic, artistic, and scientific. Further, protection is guaranteed by an effective program characterized by strict application of techniques, and educational and tourism uses are mainly for social benefit, while economic benefits must be controlled, in order not to impair the significance of cultural heritage. In addition, when restoration or moving a site is imperative, the processes must be guided by reasonable regulations.

To ensure that the China Principles are fully effective in China's heritage preservation work, SACH organized a special panel of experts and consultants to review the drafts. The China Principles were formally issued by China ICOMOS—the national committee of the International Committee on Monuments and Sites—with the approval of SACH, in October 2000.

The China Principles have now been adopted in many parts of China as a lawlike document. For example, the recent

drafting of the master plans for both the Mogao Grottoes and for the Chengde Imperial Summer Resort and its outlying temples in Hebei province is the product of the application of the China Principles. At both sites, the participation of staff in the process was critical to the writing of the plans. Due to the China Principles, the result is more standardized in terms of scientific protection and management of cultural heritage.

The Chinese, American, and Australian participants who drafted the China Principles have different political, historical, and cultural backgrounds. The success of their cooperative work demonstrates that future collaborations are not only necessary but also feasible in the area of heritage protection (Zhang Bai 2005).

Successful Collaboration in Cultural Heritage Protection

For more than fourteen years, the Dunhuang Academy and the GCI have successfully worked together to address sand migration problems, ambient and microenvironmental monitoring tasks, color monitoring and wall painting conservation, visitor capacity study and management issues, and master planning and training. Some of the key factors behind this success that may help other international collaborations are described below.

- Both parties are recognized for their accomplishments in heritage preservation and have hardworking, dedicated young staff, led by experienced, creative, and considerate professionals.
- The collaboration has focused on the most urgent issues or issues that had been greatly delayed because of technical difficulties. For example, at Mogao, both parties sought to understand the complex causes of the deterioration of the wall paintings and sculpture and to determine how wind, sand migration, moisture movement, and the gradual collapse of the cliffs were damaging the grottoes.
- Special attention was given to effective management of the teams from different countries. To avoid misunderstandings and interruptions of the collaborative work, special attention was given to the clarification of responsibilities, to overall organization, to the timely review of progress, and to coordination. For example, during phases of the

Mogao wall painting component of the project, experts from many countries were invited to assess the work. This process greatly promoted understanding, respect, and trust among the organizations and personnel concerned.

- Techniques and instrumentation for protecting cultural heritage were continually upgraded. For example, documentation methods introduced from abroad brought about breakthroughs in the treatment of the disruption of plaster and wall painting at Mogao Grottoes; this problem had puzzled Chinese experts for many years.
- Due attention was paid to the professional training of staff members. Many of the young and midcareer staff members from China were sent to the GCI for advanced study, and on their return they were given important roles in work involving international cooperation. Continued training and subsequent fieldwork helped to expand their work experience and in the long run benefited the research and conservation work of Dunhuang Academy (Fan Jinshi 2002).

Other International Collaborations

In addition to its work with the GCI, China has entered into a number of international collaborations that have improved the country's efforts to protect its cultural heritage. Some of these successful projects are described here.

Chinese-German Collaborations

International cooperation to protect the cultural heritage of Shaanxi province began in 1989 when China's State Committee of Science and Technology and the German Ministry of Technology signed an agreement that established a cooperative project. Over the past sixteen years, the cooperative effort of the Archaeological Institute of Shaanxi Province and the Mainz Römisch-Germanisches Zentral Museum has resulted in the establishment of a modern conservation laboratory and the conservation of a Tang dynasty (618–907 C.E.) underground palace in Famensi, as well as computer data collection and mapping of the Tang dynasty royal tombs, which laid the foundation for future examination and protection of the tombs.

In 2001 the two parties signed another agreement establishing an ancient silk and mural painting restoration

laboratory at the Xian Archaeology Research Institute. The laboratory has successfully conserved wall paintings from the Eastern Han dynasty (25–220 C.E.) and silk remnants found in Famensi, six of which have been displayed at exhibitions. The Bavarian State Conservation Office also collaborated with the Museum of the Terracotta Warriors and Horses and the Cultural Relics Conservation Center of Xi'an in the conservation of color paintings from the Qin and Han dynasties (221 B.C.E.–220 C.E.) and of painted sculptures in the Grand Buddha Temple of Bin Xian county. They also worked together to develop a magnetic mapping device used in archaeology.

Chinese-Japanese Collaboration

With financial support from the Japan Funds-in-Trust for the Preservation of the World Cultural Heritage, UNESCO organized a joint project to preserve the Thousand Buddha Grottoes in Kumtura in Xinjiang Uyghur Autonomous Region. In 2001 the Cultural Relics Bureau of Xinjiang and the Beijing office of UNESCO successfully undertook the first phase of the project: mapping and geologic survey of the site. With the collaboration of experts from China and Japan and with modern instruments, techniques, and documentation methods imported for this project, the preparation work was highly successful, and the data acquired jointly by the international team laid a solid foundation on which to continue this effort.

Learning from Failure

There is no denying that some collaborative projects ended in failure, but here too lessons can be learned. The reasons for failure were many; for example, some projects were too ambitious and impracticable; misunderstanding and even suspicion arose as a result of the language barrier; a lack of timely coordination resulted in the cessation of some projects; excessive focus was placed on funding and equipment and not on staff training, resulting in wasted money and the misuse of high-technology instrumentation; some projects were undermined by personal gain (for example, one party was concerned solely with acquiring information and the other party with acquiring equipment funding); disagreements in methodology and theories arose when they were not reconciled by prior negotiation or when one party's ideas were imposed on the other; and a lack of mutual respect made reconciliation and negotiation impossible.

Protecting China's Cultural Heritage: The Next Steps

The successes of previous collaborations on the protection of China's cultural heritage have stimulated interest in seeking further cooperation. Increasing support for this work, both moral and financial, from the Chinese government and the public is attracting greater attention from overseas. Summarized below are suggestions for maximizing future international collaborations.

Prioritize needs. Chinese authorities should concern themselves with issues of highest priority, for example, professional training, management experience, specification and standards establishment, and restoration technology. In terms of conservation challenges, emphasis should be placed on stabilization of earthen archaeological sites, preservation of wall paintings in underground tombs, prevention of decay and termite infestation in wooden constructions, and cleaning and stabilization of textiles, as well as calligraphic and painted scrolls. Further, it is advisable that imported advanced technologies be combined with traditional Chinese craftsmanship so as to maximize the benefits of both.

Publicize and educate. Efforts must be made to make the Chinese public aware of the importance of heritage conservation and encourage their participation. In addition, specialized education should be offered to people who are engaged in the work.

Use foreign expertise to its fullest. Much of the advanced equipment and technology and management techniques and experience acquired from overseas are used only sparingly in China and not to their full potential.

Engage upper management. International exchanges among people at the highest levels of management are equally important. These are the people who are responsible for policy making.

Learn from other countries. In the field of cultural heritage conservation, every country has a unique perspective. In Australia and the United States, for example, the concept of cultural heritage is broad. It means not only physical materials, sites, and artifacts but also a way of life, particularly in traditional relationships between humans and nature, as in native communities. At some archaeological sites, visitors include local residents, as well as tourists. In France, the concept of heritage is also broad: manufac-

turing mills that are only a century old and even buildings constructed in the twentieth century, if they are unique, are objects of protection. The Italian government draws funds for heritage protection from various channels. For instance, 0.8 percent of the country's lottery revenue is allotted to heritage protection, and a large percentage of tax revenue is also used for the same purpose. In Mexico, the National Institute of Anthropology and History is responsible for all heritage protection and has the authority to implement policies. Three binding principles are in operation in Mexico's heritage protection work: (1) heritage protection is closely related to the elimination of poverty; for example, local people are employed in heritage conservation institutions so they may earn a living without leaving their homes; (2) the protection of heritage is closely related to its reasonable use, and tourism promotes international recognition of the country's history; and (3) the government's endeavors in conservation are complemented by the efforts of volunteer organizations and private foundations. Conversely, Chinese policies, practices, and theories in heritage protection offer new insight to others.

Expand exchange topics. Exchanges are necessary in such areas as the relationship between urbanization and cultural heritage protection, the relationship between tourism and cultural heritage protection, and the preservation of whole cities or towns with historic and cultural values.

Conclusion

China is fully committed to preserving and safeguarding its cultural heritage. Two important conferences were recently held in China: the twenty-eighth annual conference of the World Heritage Committee and the fifteenth General Assembly of ICOMOS (2005). This demonstrates that the Chinese government is making a great effort to encourage international cooperation at a high level and that China is entering the international arena of heritage conservation by courageously shouldering its share of the responsibility as regulated by international conventions and agreements. We hope that the efforts and contributions of the Chinese people will allow the world to realize the beauty and importance of heritage in China and the need for its protection and conservation.

References

- Agnew, N., and M. Demas, eds. 2004. *Principles for the Conservation of Heritage Sites in China = Zhongguo wen wu gu ji bao hu zhun ze [Chinese-language document] issued by China ICOMOS; approved by the State Administration of Cultural Heritage*. Los Angeles: Getty Conservation Institute.
- Australia ICOMOS. 2000. *The Burra Charter: Australia ICOMOS Charter for Places of Cultural Significance (1999): With Associated Guidelines and Code on the Ethics of Co-Existence*. Australia ICOMOS. www.icomos.org/australia/burra.html.
- Fan Jinshi. 2002. International cooperation on Mogao Grottoes of Dunhuang. Conference on Conservation of China's Cultural Heritage, Organized by SACH, Beijing. Unpublished.
- Zhang Bai. 2005. Preface. In *Proceedings of ICOMOS 15th General Assembly and Scientific Symposium, Xi'an, China, 17-21 October 2005 = Actes du 15ème Assemblée Générale et Symposium Scientifique de l'ICOMOS*. Xi'an, China: World Publishing Corp. www.international.icomos.org/xian2005/papers.htm.

Deterioration and Treatment of Wall Paintings in Grottoes along the Silk Road in China and Related Conservation Efforts

Li Zuixiong

Abstract: *Several hundred grottoes of different sizes still remain along the Silk Road in northwestern China. The main cultural relics at those sites are splendid wall paintings and polychrome sculptures. The conservation activities that have been undertaken include studies of the overall environments of the grottoes, engineering geology surveys, rock and mineral analyses, and monitoring of the caves' micro- and macroenvironments. In addition, research has been conducted on the plaster materials used in the wall paintings and their manufacturing techniques, the pigments, and the binding media for the pigments. Assessments and analyses of wall painting deterioration were also conducted. This paper describes the components and materials of the wall paintings in several geographically widely separated grotto sites, the different forms of deterioration that affect the wall paintings, and efforts to conserve salt-disrupted and detached wall paintings.*

Many grotto sites survive along the Silk Road in northwestern China. Most of them are located in arid and semiarid areas with high annual sunshine and evaporation rates, a great temperature difference between day and night, and frequent wind and dust storms. Most cliffs into which these grottoes were excavated consist of sandstone and conglomerate with argillite cement containing clay minerals such as montmorillonite. These materials make the cliffs susceptible to water penetration. The rock is porous and loose and has poor mechanical strength (Li Zuixiong 2003).

Components of Wall Paintings in Selected Chinese Grottoes

Plaster Preparation

The materials and techniques used to make the grotto wall paintings are similar at all sites along the Silk Road in China. There are only slight regional variations and differences in construction. After the rock surface of the excavated cave was completed, layers of mud plaster were applied. Generally, there were three layers: coarse plaster, fine plaster, and a final ground layer. The clay and fibers used to make the coarse and fine plaster layers were usually obtained locally.

The characteristics of plaster analyzed from wall paintings in the Kizil, Kumtura, and Bezeklik Grottoes in Xinjiang are shown in table 1, in the Mogao Grottoes in table 2, and in the Bingling Grottoes in Gansu province in table 3. These analyses show that the coarse plaster layer was made of clay mixed with sand and straw, but the straw used varied from site to site. Thicker wheat straw was mixed in the plaster of the Kizil, Kumtura, and Bezeklik Grottoes, while thinner wheat straw was used in the plaster of the Mogao and Bingling Grottoes. The fine plaster layer was made of fine clay and sand tempered with hemp, cotton, or wool. This layer was mainly mixed with wool in the Kizil, Kumtura, and Bezeklik Grottoes; with hemp in the Mogao Grottoes; and with cotton in the Bingling Grottoes. The plaster ground, which may contain binding medium, is primarily gypsum and lime in the Kizil, Kumtura, and Bezeklik Grottoes; primarily gypsum, lime, and kaolin in the Mogao Grottoes; and primarily gypsum in the Bingling Grottoes.

Table 1 Characteristics of Plaster from the Kizil, Kumtura, and Bezeklik Grottoes, Xinjiang Autonomous Region

Grotto	Cave		Sample Location		Plaster Thickness (cm)		Fiber Content		Soil (%)	Sand (%)	
	No.	Time Period			Coarse	Fine	Coarse	Fine			
Kizil	48	4th century	Main chamber		0.5-2.0	0.2	0.01	straw	hemp	57	43
	48	4th century	West wall of corridor at bottom		0.5-2.0	0.2	0.01	straw	hemp	37	63
	77	6th century	East wall of western corridor		0.5		0.01	straw	straw	34	66
	47	4th century	Wall painting fragment				0.01	straw	wool	49	51
	38	4th century	Wall painting fragment		1.5-2.0		0.01	straw	wool	44	56
	179	7th century	East wall of main chamber		2.0		0.02	straw	hemp	42	58
	34	5th century	West wall		1.0	0.5	0.02	straw	hemp	31	69
	58	7th century	West wall of main chamber		2.0	0.5	0.02	none	hemp	55	45
	186	7th century	North wall of main chamber		1.0	0.3	0.02	straw	hemp	39	61
	180	8th century	Wall painting fragment		3.0	0.2-0.5	0.02	straw	hemp	76	24
Kumtura	178	7th century	Bottom of west wall		3.0	0.5	0.02	straw	hemp	33	67
	27	7th century	Entry to west corridor		3.0	0.2	0.02	straw	hemp	52	48
	10	8th century	Wall painting fragment					straw	wool	71	29
	16	8th century	Wall painting fragment					hemp	hemp	68	32
	28	7th century	Wall painting fragment		1.0	0.5		straw	wool	71	29
	37	7th century	Fragment of polychromed statue		2.0-3.0	0.5	0.02	straw	hemp	72	28
	18	Sui dynasty (581-618)	Wall painting fragment		4.0-5.0	0.2	0.02	straw	hemp	48	52
	28	Five Dynasties (907-79)	Wall painting fragment		2.0	0.3	0.02	straw	hemp	34	66
Bezeklik	40	14th century	Wall painting fragment		3.0	0.3	0.02	straw	hemp	50	50

Table 2 Characteristics of Plaster from the Mogao Grottoes, Dunhuang

Cave No.	Dynasty	Sample Location	Plaster Thickness (cm)			Fiber Content		Soil (%)	Sand (%)
			Coarse	Fine	Ground Layer	Coarse	Fine		
268	Late Western Jin to end of Southern and Northern dynasties	Bottom of west wall	3.0	0.3–0.4	0.01	straw	hemp	59	41
275	Late Western Jin to end of Southern and Northern dynasties	Bottom of north wall	3.0	0.1–0.2	0.01	straw	hemp	56	44
263	Late Western Jin to end of Southern and Northern dynasties	Middle of south wall	1.5–2.0	0.5	0.01	straw	straw	49	51
259	Northern Wei	North side of west wall	3.0	0.2–0.3	0.01	straw	hemp	55	45
260	Northern Wei	Bottom of west wall	2.0	0.5	0.01	straw	hemp	40	60
249	Western Wei	Bottom of north wall	3.0–4.0	0.3	0.01	straw	hemp	65	35
285	Western Wei	Bottom of east side of south wall	3.0	0.3	0.01	straw	straw	46	54
288	Western Wei	Fragment of wall painting	2.0–2.5	0.3	0.01	straw	hemp	45	55
290	Western Zhou	North side of east wall	2.0–3.0	0.2	0.01	straw	hemp	73	27
56	Sui	Bottom of niche in west wall	2.0–3.0	0.5–1.0	0.02	hemp	hemp	80	20
302	Sui	Bottom of south wall	2.0–3.0	0.5	0.02	straw	hemp	82	18
283	Early Tang	Bottom of north wall	2.0–3.0	0.5	0.02	straw	none	60	40
60	Early Tang	Bottom of niche in west wall	2.0–3.0	0.5	0.02	straw	none	53	47
68	Early Tang	Bottom of south wall of niche	2.0–3.0	0.5	0.02	straw	hemp	41	59
79	High Tang	West side of south wall of antechamber	2.0–3.0	0.5–1.0	0.02	straw	hemp	61	39
172	High Tang	South side of west wall of antechamber	3.0	1.0	0.02	straw	hemp	40	60
48	High Tang	North wall of main chamber	3.0	0.5–1.0	0.02	straw	straw	62	38
197	Mid Tang	Bottom of niche in main chamber	3.0–4.0	0.2	0.02	straw	straw	41	59
231	Mid Tang	Bottom of southwest corner of main chamber	3.0–4.0	0.5–1.0	0.02	straw	hemp	34	66
236	Mid Tang	Bottom of niche in main chamber	1.0–2.0	0.5	0.02	straw	hemp	50	50
107	Late Tang	Bottom of northeast corner of main chamber	2.0	0.5–1.0	0.02	straw	hemp	20	80
82	Late Tang	Bottom of niche	2.0–2.5	0.5	0.02	straw	hemp	33	67
9	Late Tang	East side of central column	2.0–3.0	0.15–0.2	0.02	straw	hemp	35	65
334	Five Dynasties	North wall of main chamber corridor	2.0–3.0	0.4	0.02	hemp	hemp	46	54
5	Five Dynasties	Bottom of north side of west wall	1.0–1.5	0.3	0.02	straw	hemp	58	42
40	Five Dynasties	Bottom of south wall	2.0–3.0	0.5	0.02	none	hemp	27	73
365	Song	Fragment of wall painting	1.0–1.5	0.5	0.02	straw	hemp	34	66
25	Song	Southern wall of corridor	2.0	0.5–1.0	0.02	straw	hemp	50	50
378	Song	Bottom of north side of east wall	2.0–3.0	1.0	0.02	straw	hemp	45	55
367	Western Xia	Bottom of north wall	1.5–3.0	0.3–0.4	0.02	straw	hemp	46	54
352	Western Xia	Bottom of north wall	2.0	0.5	0.02	hemp	hemp	48	52
477	Yuan	Top of north wall of corridor	2.0	0.5	0.02	straw	hemp	14	86
465	Yuan	Bottom of south side of east wall	2.0–3.0	0.5	0.02	straw	hemp	36	64

Table 3 Characteristics of Plaster from the Bingling Temple Grottoes, Yongjing

Cave No.	Dynasty	Sample Location	Plaster Thickness (cm)			Fiber Content		Soil (%)	Sand (%)
			Coarse	Fine	Ground Layer	Coarse	Fine		
169	Western Qin	Fragment of wall painting	1.5–2.0	0.5–1.0	0.01	none	none	33	67
6	Northern Zhou	Fragment of wall painting	2.0	0.5	0.01	hemp	hemp	44	56
172	—	Fragment of wall painting	2.0	0.5–1.0	0.01	straw	cotton and hemp	77	23
70	Ming	Fragment of wall painting	2.0–3.0	0.5	0.02	straw	hemp	41	59
2	Ming	Fragment of wall painting	2.0	0.5	0.02	straw	cotton	51	49
2	Ming	Fragment of wall painting	2.0	0.5	0.02	straw	cotton	62	38
2	Ming	Fragment of wall painting	2.0	0.5	0.02	straw	cotton	49	51
5	Ming	Fragment of wall painting	2.0	1.0	0.02	straw	cotton	34	66
3	Ming	Fragment of wall painting	2.0	0.3	0.02	straw	cotton	49	51
4	Ming	Fragment of wall painting	3.0	1.0	0.02	straw	cotton	41	59

Pigments

Results from X-ray diffraction analysis of pigments from the Kizil Grottoes are shown in table 4, from the Mogao Grottoes in table 5, and from the Maijishan Grottoes in table 6.

The Kizil Grottoes are the earliest representative grottoes in China. Kizil wall painting colors are reds, primarily vermilion and red lead, which have mostly discolored, and red ocher; the blues are lapis lazuli; the greens are copper hydroxy chloride minerals such as atacamite; the brownish black is PbO_2 , which is produced by the oxidation of red lead; and the whites are mainly gypsum.

At the Mogao Grottoes, red ocher was the primary pigment used in the early-period caves, while vermilion and red clay, which have discolored or faded, were extensively used in the mid- and late-period caves, respectively. Blue is primarily azurite, with lapis lazuli used to a lesser extent. Green is atacamite, the primary pigment used in early- and late-period caves, while malachite was used in mid-period caves. The primary brownish black pigment is PbO_2 . Whites were mainly kaolin, calcite, and gypsum.

The red pigments used in wall paintings at the Maijishan Grottoes are primarily vermilion and red clay, blue is mainly lapis lazuli, and green is malachite, with atacamite used to a lesser extent. The primary brownish black pigment is PbO_2 . Whites are mainly gypsum, with calcite used to a lesser extent.

The analytical results described above show that the pigments used at the Mogao and Maijishan Grottoes are

similar, but they differ significantly from those used at the Kizil Grottoes.

Binding Medium

High-performance liquid chromatography was used to analyze the binder in the wall paintings at the Mogao and Kizil Grottoes (Li Shi 1992). The results show that the binder is animal glue, probably made from ox hide (Guo Hong, Li Zuixiong, Song Dakang, et al. 1998).

Deterioration of Wall Paintings

Deterioration of the wall paintings includes plaster disruption, paint flaking, detachment, discoloration, and fading. The wall paintings are also affected by mold and soot.

Plaster Disruption

The preparatory plaster layers applied to the cave walls are highly susceptible to salt deterioration. Salts in or absorbed by the plaster will be moved by moisture and deposited below and on the surface of the wall paintings. If humidity reaches certain levels, salts will deliquesce and the plaster swell. On redrying, the dissolved salts recrystallize, and repeated cycles of salt lead to disruption of the plaster and paint layers (Guo Hong, Li Zuixiong, Song Dakang, et al. 1998; Guo Hong, Li Zuixiong, Qiu Yuanxun, et al. 1998) (figs. 1, 2).

Table 4 Analysis of Pigments from Kizil Grottoes, Xinjiang Autonomous Region

Time Period	Cave No.	Pigment Analysis by X-Ray Diffraction				
		Red	Blue	Green	Brownish Black	White
6th century	77	Red ocher		Copper hydroxy chloride*	PbO ₂	Gypsum + calcite
4th century	38	Red ocher	Lapis lazuli	Copper hydroxy chloride	PbO ₂	Gypsum + anhydrite
4th century	114	Vermilion	Lapis lazuli	Copper hydroxy chloride	PbO ₂	
8th century	180	Vermilion + red ocher	Lapis lazuli			
7th century	100			Copper hydroxy chloride	PbO ₂	Gypsum + quartz + calcite + anhydrite
7th century	179		Lapis lazuli	Copper hydroxy chloride	PbO ₂	
5th century	171	Vermilion, red lead + PbO ₂	Lapis lazuli		PbO ₂	
7th century	New No. 1	Vermilion, vermilion + red ocher, red lead	Lapis lazuli	Copper hydroxy chloride	PbO ₂	Gypsum + calcite
7th century	186	Red lead + PbO ₂	Lapis lazuli	Copper hydroxy chloride	PbO ₂	Gypsum + anhydrite + calcite
7th century	135	Red ocher				Calcite + gypsum

*Cu²⁺(OH)₃Cl.**FIGURE 1** Plaster disruption of wall painting in cave 26, Mogao Grottoes, Dunhuang.**FIGURE 2** Blistering and disruption of wall painting in cave 35, Mogao Grottoes, Dunhuang.

Table 5 Analysis of Pigments from the Mogao Grottoes, Dunhuang

Time Period	Dynasty	Pigment Analysis by X-Ray Diffraction				
		Red	Blue	Green	Brownish Black	White
Early period	Sixteen Kingdoms, Northern Wei, Western Wei, and Northern Zhou	<i>Primary:</i> Red ocher	<i>Primary:</i> Lapis lazuli	<i>Primary:</i> Copper hydroxy chloride	<i>Primary:</i> PbO ₂	<i>Primary:</i> Kaolin
		<i>Secondary:</i> Vermilion, vermilion + red lead, red ocher + red lead	<i>Secondary:</i> Small amount of azurite	<i>Secondary:</i> Small amount of malachite	<i>Secondary:</i> PbO ₂ + Pb ₃ O ₄	<i>Secondary:</i> Talc, small amount of calcite, mica, and gypsum
Middle period	Sui, Early Tang, High Tang, Middle Tang, and Late Tang	<i>Primary:</i> Vermilion	<i>Primary:</i> Azurite + lapis lazuli	<i>Primary:</i> Malachite <i>Secondary:</i> Small amount of copper hydroxy chloride, malachite + copper hydroxy chloride	<i>Primary:</i> PbO ₂ <i>Secondary:</i> Trace of PbO ₂ + Pb ₃ O ₄	<i>Primary:</i> Calcite <i>Secondary:</i> Talc, kaolinite, mica, gypsum, small amount of chlorine, lead, and anglesite
		<i>Secondary:</i> Red lead, red clay, vermilion + red lead, red clay + red lead	<i>Secondary:</i> Small amount of azurite + copper hydroxy chloride			
Late period	Five Dynasties, Song, Western Xia, Yuan, and Qing	<i>Primary:</i> Red clay	<i>Primary:</i> Lapis lazuli, azurite, and ultramarine (synthetic lapis lazuli)	<i>Primary:</i> Copper hydroxy chloride <i>Secondary:</i> Malachite + copper hydroxy chloride	<i>Primary:</i> PbO ₂ <i>Secondary:</i> Small amount of PbO ₂ + Pb ₃ O ₄ , trace of Fe ₃ O ₄	<i>Primary:</i> Gypsum <i>Secondary:</i> Calcite, small amount of talc, mica, chloride, lead, and Mg ₃ Ca(SO ₄) ₄
		<i>Secondary:</i> Red clay + red lead, vermilion + red lead, trace of realgar + red lead	<i>Secondary:</i> Small amount of azurite + malachite			

Table 6 Analysis of Pigments from the Maijishan Grottoes, Tianshui

Dynasty	Cave No.	Pigment Analysis by X-Ray Diffraction				
		Red	Blue	Green	Brownish Black	White
Northern Wei	70	Vermilion	Lapis lazuli	Malachite	PbO ₂	Talc + gypsum + calcite
	74	Vermilion	Lapis lazuli	Malachite	Fe ₃ O ₄	Gypsum
	127	Vermilion	Lapis lazuli			Calcite
Northern Wei (rebuilt during Song)	93	Red clay			PbO ₂	Gypsum + mica
Western Wei	44	Red clay		Malachite	PbO ₂	Talc + gypsum
Northern Zhou	94	Red clay	Lapis lazuli	Malachite	PbO ₂	Gypsum + calcite
Sui	37	Red clay		Malachite		Gypsum
Yuan	127			Copper hydroxy chloride	PbO ₂	
Ming	9	Red clay		Copper hydroxy chloride		Anhydrite + gypsum

FIGURE 3 Flaking paint layer of wall painting in cave 428, Mogao Grottoes, Dunhuang.



Flaking

A number of conditions reduce adhesion of the paint layer to the plaster ground, causing the paint to lift and peel in flakes (fig. 3). These include the following:

- too much binding medium was used in the paint;
- the binding medium has not entirely deteriorated, but any glue in the ground layer has aged, or less glue was used in the ground layer;
- the plaster ground has been deteriorated by salts; or
- the surface of the plaster was made so hard and smooth that the paint layer could not attach properly to it.

The lifting and peeling of the paint and ground layers from the fine clay layer of the plaster is caused primarily by soluble salts, which affect the cohesion of the clay (fig. 4).



FIGURE 4 Plaster detachment of wall painting in cave 6, Yulin Grottoes, Dunhuang.

At the Mogao Grottoes some wall paintings were over-painted in subsequent dynasties, and this has also led to flaking. In these cases, a new ground layer was spread over a wall painting and the added ground then painted with a new scene. These new paintings tended to flake, however, either because the glue used in the original wall painting had aged or because the surface was already disrupted.

Detachment of the Plaster Layer and the Paint Layer

The primary reason for the detachment or separation of the plaster from the cave rock is that the rock surface was too weathered when it was originally plastered and painted. At the Mogao and Yulin Grottoes and the Western Thousand Buddha Caves, the cliffs are composed of weak, poorly cemented conglomerate. Because of this, the plaster layer easily detaches from the rock during earthquakes and may fall immediately or at a subsequent time. Also, water easily penetrates the conglomerate, wetting the plaster and causing large areas of detachment between the rock surface and the plaster (fig. 5). Many roof paintings in the upper-level caves have already fallen, due to rainwater penetration. This is seen especially at the Yulin Grottoes. In addition, sand and pebbles from the weathered cliff frequently have accumulated in the detached areas between the plaster and rock surface. This sand and pebble buildup pushes out on the plaster and contributes to loss.

A special situation exists at the Mogao Grottoes. Many of these caves are narrower at the upper part and wider



FIGURE 5 Large area of plaster loss in wall painting in cave 368, Mogao Grottoes, Dunhuang.

at the base; hence the walls incline inward slightly. This puts additional gravitational strain on the plaster, which is often heavy, having been applied thickly to cover the uneven, coarse-grained rock surface of the side walls, or does not adhere well to the wall because of the coarse and loose rock surface. Thus the inclination of the side walls puts additional strain on the already at-risk plaster, and the plaster with wall paintings in these caves easily collapses when disturbed by earthquakes or other types of vibration.



FIGURE 6 Pigment discoloration and fading in wall painting in cave 205, Mogao Grottoes, Dunhuang.

Discoloration and Fading

The pigments used in the Mogao murals were made from minerals. There are two reasons for color fading. One is that the mineral pigments have weathered or lost water from their crystalline structure, so chroma and brightness are reduced. The other is that the organic binding media used with the pigments have aged (Li Zuixiong 1992; Michalski and Li Zuixiong 1989; Su Bomin, Hu Zhide, and Li Zuixiong 1996; Li Tiezhao and Xiang Xiaomei 1993; Sheng Fenling, Li Zuixiong, and Fan Zaixuan 1990).

Experiments on pigment samples from the Mogao Grottoes, carried out by the Dunhuang Academy, contribute to an understanding of the discoloration and fading seen in the wall paintings (fig. 6). The three red pigments primarily used in the Mogao wall paintings are vermilion, red ochre (also called red iron oxide), and red lead. Experimental results show that by itself red ochre is the most stable of these pigments, and it does not change regardless of conditions, from high humidity (90% RH) to extreme dryness (0–48% RH), nor is it affected by light. However, the binding materials that were used with the red ochre have aged over the centuries, causing the paint to powder and the color to fade through loss of pigment.

The experiments also showed that humidity does not cause fading of vermilion, made from the mineral cinnabar (mercuric sulfide). However, with long exposure to light, the vermilion turns black because some of the pigment's crystals change into the black form of cinnabar.

FIGURE 7 Soot deposits on ceiling wall painting in cave 56, Mogao Grottoes, Dunhuang.

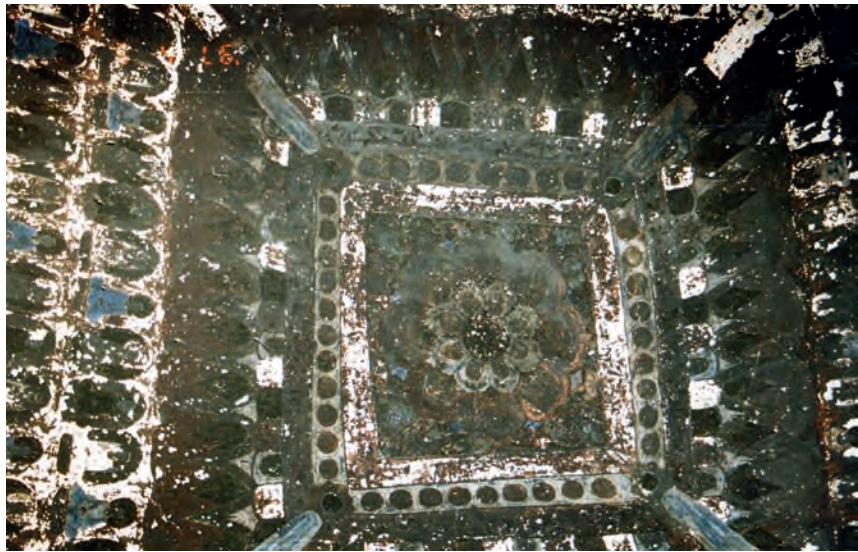

Experiments also demonstrate that red lead changes very quickly under high humidity (90% RH) and when illuminated by fluorescent light. This explains why the red lead in the wall paintings has been oxidized into brownish black PbO_2 . However, red lead is light stable under dry (0–48% RH) conditions. Further experiments show that red lead fades markedly under the alkaline conditions of the clay plaster and when the relative humidity reaches 70 percent. The same experiments showed that the green pigments (malachite, copper hydroxy chloride or atacamite) and the blue pigments (azurite, lapis lazuli) used in the Mogao Grottoes are relatively stable.

These studies provide scientific data that can be used to help prevent wall paintings from further discoloration and pigment loss, as well as to establish safe illumination levels in the caves.

Soot

Some caves at the Mogao Grottoes were occupied by Russians in the 1920s, after the Russian Revolution. They made fires to keep warm and to cook, causing heavy soot deposits on the wall paintings. Some soot has also resulted from burning incense, presumably from past religious ceremonies (fig. 7).

Conservation of the Chinese Wall Paintings

Since the founding of the Dunhuang Academy in the early 1940s, a procedure for the treatment of deteriorating wall paintings has been developed. This procedure is described

briefly below. The collaborative project between the Dunhuang Academy and the Getty Conservation Institute for the conservation of cave 85 has resulted in many innovations or modifications, as described elsewhere in this volume.

Flaking

Five steps have been taken to conserve flaking wall paintings:

1. Dust removal: A broad brush with soft wool or an air puffer is used to gently clean dust from the surface.
2. Adhesive injection: A syringe is used to slowly inject a concentration of 2.5 to 3 percent of blended adhesive (polyvinylacetate aqueous emulsion with added polyvinyl alcohol) into the lower part of the flaking paint layer or into cracks. The syringe is inserted into a small hole made in an unimportant part of the mural or under the larger paint flakes. If there is no crack, then an injection hole is made in an unimportant area of wall painting or in the area where large flakes are located.
3. Pressure application to treated areas: A cotton ball made of absorbent cotton fiber wrapped in white silk is used to apply pressure to the treated areas of the mural to re-lay lifting flakes.
4. Adhesive spray: Adhesive is sprayed over the treated area. There are two purposes for this step: to reinforce the paint layer, especially in cases where the painting has not yet flaked, and to repair paint that has detached from the plaster layer but without

flaking, which cannot be seen. The paint layers may quickly blister after being sprayed with adhesive. In this case, adhesive is injected into a small hole made in an unimportant area of the painting as in step 2.

5. Surface rolling after adhesive spraying: After the adhesive-treated surface of the mural has dried to about 70 percent, it is covered with white silk and pressed with a soft rubber roller. Care is taken to apply pressure evenly to prevent roller marks on the painting or to prevent the treated paint layer from sticking to the white silk. The roller should not be used when the sprayed area is more than 80 percent dry, or the painting will be damaged due to the pressure as the adhesive becomes sticky.

Detachment

Detachment of the full thickness of the plaster from the conglomerate is the most difficult form of deterioration to treat. In order to do so, we must first deal with moisture in the cave's environment, after which appropriate repair materials and techniques are used to secure the paintings in situ.

Grouting is the primary treatment method for conserving detached wall paintings. Mechanical anchor rods in the rock have also served as an auxiliary technique to pin areas of detached wall painting. The grouting process is as follows:

1. Boring of grouting holes: Several grouting holes, 0.5 to 1.0 centimeter in diameter, are bored into unimportant parts of the detached murals, proceeding from bottom to top. Then a flexible rubber tube, for delivery of the grout, 20 centimeters long and nearly the same diameter as the hole, is inserted into each hole.
2. Application of wooden wall press: A wooden press covered with a cotton blanket and soft paper as the liner is pressed against the area of the wall painting to secure the area being treated.
3. Grouting: Using slight pressure, liquid aqueous grouting liquid is inserted with a syringe through the rubber tubes into the holes that have been bored through the detached areas of the wall painting. This step proceeds from bottom to top; as holes are filled, the rubber hose is immediately stoppered, then the next upper hole is grouted, and so on.
4. Reattachment: The grouting tubes, which were stoppered when the wall painting was reattached, are unstoppered, so that the superfluous liquid can

extrude from the pipes when pressure is applied to the board using a screw or jack to re-adhere the wall paintings.

5. Press removal: When the grout is 70 percent solidified, the wooden press is removed, and the rubber grouting tubes are cut off. After the grout has completely solidified, the grouting holes are filled with the same materials as in the original plaster, so that the restored wall surface looks like the original.

References

- Guo Hong, Li Zuixiong, Qiu Yuanxun, Tang Jiayong, and Yang Fujia. 1998. [Research on efflorescence of wall paintings in the Mogao Grottoes 2]. *Dunhuang Research* 4: 159–72.
- Guo Hong, Li Zuixiong, Qiu Yuanxun, Xu Zhizheng, Tang Jiayong, and Yang Fujia. 1999. [A study of the wall painting efflorescence in the Mogao Grottoes, Dunhuang, 3]. *Dunhuang Research* 3: 153–75.
- Guo Hong, Li Zuixiong, Song Dakang, Qiu Yuanxun Xu Zhizheng, Tang Jiayong, and Yang Fujia. 1998. [Research on efflorescence of wall paintings in the Mogao Grottoes 1]. *Dunhuang Research* 3: 153–63, 188.
- Li Shi. 1992. [The application of high-speed liquid chromatography technology on wall painting binding media analysis]. *Dunhuang Research* 4: 53–60.
- . 1995. [Quantitative analysis of the binding media in the Dunhuang murals]. *Dunhuang Research* 3: 29–46.
- Li Tiezhao and Xiang Xiaomei. 1993. [A study of the green and blue pigment used in the wall paintings at the Mogao Grottoes, Dunhuang]. In *Dunhuang yan jiu wen ji*, Di 1 ban ed., Dunhuang yan jiu yuan (China), 1: 71–86, 305. Lanzhou: Gansu min zu chu ban she.
- Li Zuixiong. 1992. [A study of red pigments in Mogao murals and their discoloration mechanism]. *Dunhuang Research* 3: 41–55.
- . 2003. *Si chou zhi lu gu yi zhi bao hu = Conservation of Ancient Sites on the Silk Road*. Beijing: Ke xue chu ban she.
- Li Zuixiong, Fan Zaixuan, and Sheng Fenling. 1992. [New developments in the research of color changes in red lead, vermilion, and hematite]. *Dunhuang Research* 1: 89–118.
- Michalski, S., and Li Zuixiong, trans. 1989. [Discoloration of red ocher, vermilion, and red lead with the influence of light and humidity]. *Dunhuang Research* 3: 80–93.
- Sheng Fenling, Li Zuixiong, and Fan Zaixuan. 1990. [Humidity is the main cause for discoloration of minium]. *Dunhuang Research* 4: 98–113.
- Su Bomin, Hu Zhide, and Li Zuixiong. 1996. [A study of the mixed red pigments used in the wall paintings of Dunhuang]. *Dunhuang Research* 49 (3): 149–62, 187.

Safeguarding Silk Road Sites in Central Asia

Laurent Lévi-Strauss and Roland Lin

Abstract: *Since the mid-1990s UNESCO has been working to safeguard cultural sites along the Silk Road of central Asia and in China. This work is possible thanks to the generosity of the Japanese government, which in 1993 set up the UNESCO/Japanese Funds-in-Trust for the Preservation of the World Cultural Heritage. This paper reviews four projects supported by the trust to safeguard sites in Kazakhstan, Kyrgyzstan, Uzbekistan, and Tajikistan. These important archaeological sites further our understanding of the Silk Road's history, economics, and social organization.*

Since the mid-1990s UNESCO has been working to safeguard cultural sites such as Buddhist grottoes along the Silk Road of central Asia and in China. This work is possible thanks to the generosity of the Japanese government, which in 1993 set up a special trust fund at UNESCO to aid the organization in its efforts to preserve and promote the cultural heritage of the world. As of 2004, Japan's total contribution to the fund for the Silk Road sites of central Asia and in China has amounted to approximately U.S.\$5 million. This paper reviews four projects being carried out in Kazakhstan, Kyrgyzstan, Uzbekistan, and Tajikistan under the UNESCO/Japanese Funds-in-Trust for the Preservation of the World Cultural Heritage.

Otrar, Kazakhstan

The first project supported under the UNESCO/Japanese Funds-in-Trust program is the conservation and restoration of ruins at the Otrar Oasis (fig. 1). Covering 200 square kilometers at the confluence of the Arys and Syr Darya Rivers in southern Kazakhstan, the Otrar Oasis consists of a largely

uninhabited and unspoiled landscape containing the ruins of six medieval towns, along with an extensive system of irrigation canals dating back two thousand years (Baipakov 1991: 66–71).

The towns, the largest and most important of which is Otrar, were first excavated in 1969 by the Kazakh archaeologist Karl Baipakov and other Russian archaeologists, revealing the spectacular mud-brick structures of these large, typically central Asian settlements, which comprise a central citadel, a town area, suburbs, and earthen fortifications. It is possible to reconstruct the complex history of the region by studying these sites as they flourished over a long period, typically from the first to the fifteenth century C.E. (Jansen et al. 2003).



FIGURE 1 Aerial view of the Otrar Oasis. © UNESCO/Japan Trust Fund Otrar Project in Kazakhstan



FIGURE 2 Ruins of the Otrar mosque (fourteenth–fifteenth century). © UNESCO/Japan Trust Fund Otrar Project in Kazakhstan

The excavated ruins at the Otrar Oasis had been left open to the elements and were in danger of rapid erosion and deterioration. The UNESCO project aims to conserve the ancient town, or *tobe*, of Otrar and to preserve it for future generations. *Tobe* literally means “hill” or “mound” and refers to the small knolls on which the towns were originally built. Emergency conservation measures are also being carried out at the other *tobes* at the oasis. These emergency measures include cleaning, painting, repairing cracked bricks, supporting destabilized parts of the brickwork, backfilling, and erecting protective shelters and temporary fencing. Laboratory tests have been conducted on building materials and soil samples, and the results have been used to develop and test mixtures and techniques for conserving the mud bricks used in construction.

The Otrar conservation project was approved in May 2001, and the plan of operations was signed by UNESCO and the Kazakh authorities during an official visit to Kazakhstan by the UNESCO director-general in August 2001. The work is expected to be completed in June 2006.

The UNESCO project, which also includes a major research and documentation component, encourages the development of skills and expertise of Kazakh and central Asian professionals in the field of cultural heritage conservation, notably through the conservation of Otrar’s mud-brick architecture and earthen structures (Fodde and Hurd 2004), such as its mosque (fig. 2). Furthermore, since structures similar to those at Otrar exist across central Asia and their proper conservation and safeguarding present certain technical challenges, the project emphasizes the sharing of

expertise between international specialists and those from central Asia. In this way, the project builds central Asian capacity in conservation and serves as a model for others in the region (Childe 2000). The UNESCO project at Otrar is concerned not only with conserving the site but also with enabling national and regional experts and institutions to take responsibility for site conservation and management. Because of this approach, UNESCO project consultants have provided only modest, supervisory expertise (Childe 2000). For example, UNESCO consultants organized a workshop on advanced restoration techniques and held training field trips to teach about earthen materials used in construction and how to test them. The philosophy of conservation was also addressed, as was the use of computer design techniques applied to conservation documentation. The actual physical conservation of the site is being undertaken by the Kazakh experts.

An immediate and gratifying result of this project has been increased awareness regionally and nationally of the value of the cultural heritage represented by Otrar. The project has received extensive media coverage, including a thirty-minute documentary broadcast twice in December 2004 on Kazakh television. In addition, the number of visitors to the site has increased sharply—from 9,749 in 1999 to 92,397 in 2002—which the director of the Otrar Museum attributes primarily to the large numbers of visiting school-children. Increased visitation, according to the director, is one of the greatest impacts of the Otrar project thus far (Jansen et al. 2003).

Chui River Valley, Kyrgyzstan

A second UNESCO project, begun in October 2003 and expected to be completed by 2007, aims to preserve selected Silk Road sites in the Chui River valley in northern Kyrgyzstan,¹ located between the capital, Bishkek, and Lake Issyk-Kul.² At one time this area was one of the region’s most important political, economic, and military centers, thanks to its position on the Silk Road. The valley’s ancient towns of Navikat (now Krasnaya Rechka), Suyab (now Ak Beshim), and Balasagyn (now Burana) were founded during the sixth century C.E. and later developed into centers where a symbiosis of Indian, Chinese, Sogdian, and Turkic cultures developed (Dudashvili 2001: 32–33; Buriakov 2000: 93–96). Peoples from India, Sogdia (now western Uzbekistan and parts of Kazakhstan), Syria, Persia, China, and the northern steppes settled in these towns, bringing with them their own



FIGURE 3 Excavation of a statue of the Buddha in Nirvana at the second Buddhist temple (seventh–eighth century). © UNESCO/Japan Trust Fund Chui Valley Project in Kyrgyzstan

religious and cultural traditions (Sulaimanov, Tashbaeva, and Japarov 2002: 44–45).

The Chinese pilgrim Xuanzang mentioned the towns when he visited the area around 620 C.E., when Navikat in particular was one of the most important urban settlements in the Chui River valley and in the Tian Shan region (Litvinsky, Zhang Guang-da, and Shabani Samghabadi 1996: 170–91). Archaeological excavations in and around the ancient town of Navikat have yielded a Zoroastrian fire altar and grave site in the western suburbs, Nestorian Christian votive stones in the citadel, and two Buddhist temples south of the town walls.

Figure 3 shows work on a statue of the Buddha in Nirvana at the second Buddhist temple (seventh–eighth century), which was excavated some twenty years ago by the Kyrgyz archaeologist Valentina Goryacheva and other Russian archaeologists. The temple contains a well-preserved sanctuary whose ruins were backfilled to prevent further degradation. Much of the remaining temple site, however, was not backfilled, and no protective measures were taken. UNESCO intervened and carried out urgently needed conservation, thereby preventing the loss of this unique monument of early medieval Buddhism in Kyrgyzstan (Lin 2002). The conservation work consisted primarily of laboratory analysis and field conservation. Different soils were tested to identify those most compatible with the historical mate-

rials. Experiments were conducted on different mud-brick compositions, and six test walls were built. Field conservation activities included damage assessments at Navikat and emergency backfilling. A permanent weather station was established at the site to record and monitor daily temperature, precipitation, humidity, wind velocity, and air pressure. In addition, detailed research on the climate, geology, and hydrogeology of the second Buddhist temple site has provided the additional data necessary to make decisions regarding conservation issues.

Although the UNESCO program in the Chui River valley focuses on Navikat’s second Buddhist temple, it is also concerned with conserving an Islamic tower at Balasagyn (Burana) (fig. 4) and with emergency conservation activities at the ruins of a Nestorian (Christian) church at Suyab (present-day Ak-Beshim) (fig. 5). The overall conservation program includes a strong documentation and research component, which is essential to enhance understanding of these little-known sites and to identify the best approaches for their conservation and preservation. A master plan for the conservation and maintenance of the Chui River valley cultural heritage sites is also being drawn up in preparation for their potential inscription on the UNESCO World Heritage List.



FIGURE 4 Late-tenth-century C.E. Islamic tower at Balasagyn (Burana). © UNESCO/Japan Trust Fund Chui Valley Project in Kyrgyzstan



FIGURE 5 Ruins of eighth-century C.E. Nestorian church at Suyab (Ak-Beshim). © UNESCO/Japan Trust Fund Chui Valley Project in Kyrgyzstan

Fayaz-Tepa, Uzbekistan

Southern Uzbekistan is extremely rich in cultural heritage sites that reflect the region's multicultural and multiethnic history. The region contains many important Islamic monuments, such as the mausoleum of Hakim Termezi, the Jarkurgan minaret, and the Sultan Saodat complex, as well as monuments of a secular nature, such as Kirk-Kyz castle,

the citadel and ramparts of Old Termiz,³ and the remains of the Karakhanid wharf along the Amu-Darya River. Many monuments also relate to Buddhism, such as those found at Kara-Tepa, Airtam, Zurmara, Dalverzin-Tepa, and Fayaz-Tepa, site of the third UNESCO/Japanese Funds-in-Trust project (Buriakov 2000: 54–57).

Fayaz-Tepa contains a small Buddhist temple (fig. 6) built of sun-dried mud bricks on flat land and located near the city of Termiz, in the southeastern tip of Uzbekistan. The complex, which measures 34 by 117 meters and dates to the first century B.C.E. (Al'baum 1960: 18–27), consists of a stupa (a dome-shaped religious shrine) and a monastery.

This UNESCO project, which began in August 2000 and is expected to be completed in June 2006, aims to preserve and restore the temple ruins as witness to the role played by this region in the transmission of Buddhist culture and art; to contribute to the development of sustainable economic activities at the site through the improved presentation of cultural assets and the development of tourism-related economic activities; and to build national capacity in the management of cultural resources, notably by providing professional in-service training to the experts with the Institute of Restoration, Ministry of Culture, Uzbekistan.

The Buddhist ruins at Fayaz-Tepa are an important reminder of the many cultures and religions that have contributed to Uzbekistan's history and identity. The UNESCO



FIGURE 6 Ruins of first-century C.E. Buddhist temple at Fayaz-Tepa (top); temple map (bottom); and Buddha sculpture (right) found at the site. © UNESCO/Japan Trust Fund Fayaz-Tepa Project in Uzbekistan

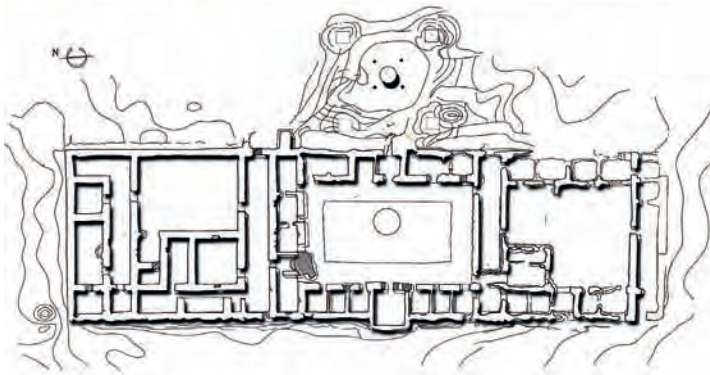

project therefore aims to build awareness of the region's multicultural and multiethnic past and present. This is especially important at a time when the peace and stability of the region are threatened by the spread of religious extremism.

Ajina Tepe, Tajikistan

The fourth UNESCO/Japanese Funds-in-Trust project, which began in May 2005 and is expected to be completed by 2008, is the preservation and restoration of the ruins of a Buddhist monastery built from the fifth to eighth century C.E. at Ajina Tepe (Hayashi 2003). This site, in western Tajikistan, is located 13 kilometers east of the city of Kurgan-Tube, a town close to the Tajik border with Afghanistan. It was excavated during the 1950s and 1960s by archaeologists from the then Soviet Union.

The monastery, which is a significant example of the Buddhist architecture of central Asia (Litvinsky and Zeimal 1971), originally consisted of two halves that made up a single large complex of religious and residential buildings, each half occupying an area of approximately 50 by 100 meters. The monastery consisted of numerous cells that served as assembly rooms for the monastic community and as refectories, as well as halls linked by winding, vaulted corridors. At the end of one corridor, a 12-meter-long statue of the recumbent Buddha in Nirvana was found on a large pedestal that occupied almost the entire length of the hall (fig. 7).

Following Tajikistan's independence from the Soviet Union in 1991 and as a result of subsequent internal conflict and civil war, the country today suffers from a serious shortage of human resources in the cultural field, including heritage and conservation specialists. It also lacks appropriate infrastructure and heritage conservation institutions. There is an urgent need for appropriate training in the fields of cultural heritage conservation and management and in capacity building, both at the technical and management levels (Lin 2004). For these reasons, UNESCO's work at Ajina Tepe also includes training of national conservation experts and officials. This should enable these professionals to undertake other, larger projects elsewhere in the country in the future.

Conclusion

The ancient sites at Otrar in Kazakhstan, in Kyrgyzstan's Chui River valley, at Fayaz-Tepa in Uzbekistan, and at Ajina Tepe in Tajikistan date from different periods in the history of the region and bear witness to the civilizations and



FIGURE 7 The 12-meter-long Buddha in Nirvana statue (7th century C.E.) from the Ajina Tepe Buddhist monastery.
© UNESCO/Japan Trust Fund Ajina Tepe Project in Tajikistan

religions that flourished in it. These sites, which had been threatened by deterioration, are being preserved for future generations thanks to the trust fund arrangements established at UNESCO by the Japanese government. A further aim of the UNESCO work is to raise awareness of the multicultural history of the region, which once stood at the crossroads of religions, cultures, and civilizations.

The four projects described in this paper, in addition to fostering educational and cultural tourism activities at the sites, are helping to build national and regional capacity in project management of cultural heritage and in conservation techniques through the exchange of expertise among international, national, and regional professionals. The practical experience gained during the projects' implementation by national and regional experts trained in the most up-to-date techniques and to international standards will allow them to undertake similar projects elsewhere in the region, with or without the direct involvement of UNESCO. This training is especially important with the loss of state funding to the culture sector in these countries after the breakup of the former Soviet Union.

Acknowledgments

Francis Childe, my colleague in the Division of Cultural Heritage at UNESCO, is responsible for the UNESCO/Japan Funds-in-Trust projects mentioned in this paper. Roland

Lin Chih-Hung manages the Otrar project in Kazakhstan and the Chui Valley project in Kyrgyzstan; Nao Hayashi and Roland Lin Chih-Hung jointly manage the Ajina Tepe project in Tajikistan. The Fayaz-Tepa project is managed by Barry Lane and Igor Chantefort of the UNESCO Office in Tashkent, Uzbekistan. Francis Childe, Roland Lin Chih-Hung, and Nao Hayashi contributed to this paper.

Notes

- 1 *Chui* and *Chuy* are common spellings for this river, although it is spelled *Shö* in the *National Geographic Atlas of the World* (8th ed.).
- 2 Issyk-Kul is spelled *Ysyk-Köl* in the *National Geographic Atlas of the World* (8th ed.).
- 3 Also spelled *Termez*.

References

- Al'baum, L. I. 1960. *Balalyk-Tepe k istorii material noi kul tury i iskusstva Tokharistana*. Tashkent: Izdatel stvo Akademii Nauk UZSSP.
- Baipakov, K. M. 1991. *Po velikomu shelkovomu puti = Along the Great Silk Road*. Alma-Ata [Kazakhstan]: Kramds-reklama.
- Buriakov, I. F. 2000. *The Cities and Routes of the Great Silk Road: On Central Asia Documents*. Tashkent: Sharg.
- Childe, F. 2000. Report of project preparation mission to Otrar, Kazakhstan: 30 October to 12 November 2000. Paris: Division of Cultural Heritage, UNESCO.
- Dudashvili, S. 2001. *Kyrgyzstan: A Land of Treasure, Wonder and Mystic Awe*. Bishkek, Kyrgyz Republic: Rarity.
- Fodde, E., and J. Hurd. 2004. *Preservation and Restoration of the Ancient City of Otrar, Kazakhstan: Conservation of Earth Sites in the Central Asian Silk Roads: Manual for the Testing and Assessment of Historic and New Earthen Materials and for Their Application within an Ethical Conservation Process*. Paris: UNESCO.
- Hayashi, N. 2003. Report on CLT/CH Survey Mission to Tajikistan (25 November–2 December 2003) for a possible Cultural Heritage Conservation Project under the Japanese Funds-in-Trust for the Preservation of the World Cultural Heritage. Paris: Division of Cultural Heritage, UNESCO.
- Jansen, M., E. Fodde, J. Hurd, M. Santana, and T. Stevens. 2003. *Preservation and restoration of the ancient city of Otrar, Kazakhstan: Interim technical report*. Paris: UNESCO.
- Lin, R. 2002. Report of project preparation mission to Krasnaya Rechka, Kyrgyzstan: 12–29 September 2002. Paris: Division of Cultural Heritage, UNESCO.
- . 2004. Report of project preparation mission to Ajina Tepa, Tajikistan: 22–29 November 2004. Paris: Division of Cultural Heritage, UNESCO.
- Litvinsky, B. A., and T. I. Zeimal. 1971. *Adzhina-Tepa: Arkhitektura, zhivopis', skulptura*. Pamiatniki drevnego iskusstva. Moscow: Iskusstvo.
- Litvinsky, B. A., Zhang Guang-da, and R. Shabani Samghabadi, eds. 1996. *History of Civilizations of Central Asia, Volume 3: The Crossroad of Civilizations: A.D. 250 to 750*. Paris: UNESCO.
- Sulaimanov, E., K. Tashbaeva, and A. Japarov. 2002. *Atlas of Central Asian Artistic Crafts and Trades*, vol. 3: *Kyrgyzstan*. Bishkek: International Institute for Central Asian Studies.

Nomination of the Silk Road in China to UNESCO's World Heritage List: Proposals for a Strategic Approach and Reference Framework for Heritage Routes

Ron van Oers

Abstract: *In the conservation discipline today, there is a tendency toward an increase in geographic scale and variety of categories in properties and sites considered for protection, conservation, and nomination to UNESCO's World Heritage List. More attention is being given to cultural landscapes, cultural ensembles in their wider natural setting, and, eventually, to protecting and managing heritage routes—defined as physical or perceived representations of frequent and repeated movement, linking places in time and space and generating an exchange of goods and ideas. Consideration of this category for protection and conservation is highly experimental, and today only four routes are registered on the World Heritage List: the Route of Santiago de Compostela in Spain and France, the Frankincense Trail in Oman, the Sacred Sites and Pilgrimage Routes in the Kii Mountain Range in Japan, and the Incense Route–Desert Cities in the Negev in Israel. The protection extends to the route itself, as well as to selected buildings and settlements located alongside it. It would be more pertinent to adopt an approach that recognizes the immaterial and diffuse nature of a heritage route and the dynamic effects of transmission and impact. All this involves the protection and conservation of a series of elements of various natures, linked by a physical or perceived artifact. UNESCO's World Heritage Centre is currently assisting the Chinese authorities in exploring the possibility for a serial nomination of the Silk Road's Oasis Route in China to the World Heritage List. This paper discusses proposals for a strategic approach and reference framework for this serial nomination, using examples of already established World Heritage sites to define appropriate strategies for conservation and management.*

Heritage routes are the latest development in a trend to expand the scale and complexity of heritage properties. Briefly, a heritage route is a series of culturally and historically important elements, incorporating tangible and intangible values, that are linked by a physical or perceived artifact, such as a road or route that may or may not still exist. Before heritage routes can be inscribed in the World Heritage List, the concept requires a consolidated approach and framework for their identification, nomination, and effective management. This paper discusses heritage routes through the application of the concept to the Silk Road in China, specifically, the section known as the Oasis Route.¹

Heritage Routes and the World Heritage List

A property can be registered on the World Heritage List only if physical evidence of its existence remains and this evidence can be protected and preserved for future generations. Physical remains that have been radically altered would not be eligible. Likewise, conservation of conjectured elements is not accepted by the international professional community, including the World Heritage Committee, as stated in the Venice Charter (International Council on Monuments and Sites 1964: art. 9). What constitutes physical evidence of a heritage route, however, is something that is still open to broad interpretation.

Physical evidence of heritage routes sometimes may be found in the form of roads, as in the case of the Camino Inca referred to by the Oxford historian Fernández-Armesto (2001: 290–92): “Historians of the early colonial period, likening the Incas to the Romans, exaggerated the uniformity of their institutions and the centralized nature of their govern-

ment. Still, the intrusive nature of their rule is apparent in the evidence they have left of how to manage a high-altitude empire: relics of the extraordinary road system.” In other cases, however, physical evidence has disappeared or been replaced by a new system. For example, the Via Appia Antica still has the same structure, whereas the 962-kilometer stretch of the Via Aurelia from Rome to Arles has been replaced by a modern road. Similarly, in the case of the Silk Road in China, almost all the original road—if one existed; much of it consisted of tracks through the desert—has disappeared and been replaced by a four-lane highway. How to deal with this?

Discussions on improved identification and representation of heritage categories have been going on at least since the early 1980s. Over the past decade, in particular, our view of the meaning and value of heritage has been refined significantly. In 1992 its interpretation was broadened tremendously with the addition of cultural landscapes as a new category for World Heritage listing and a new criterion (vi) for cultural properties. The World Heritage Committee supported this interpretation with the adoption of its *Global Strategy* (1994) and with the *Nara Document on Authenticity* (1994).

A further refinement of heritage categories is the anthropological interpretation in the cultural heritage field that has led from the protection of architectural and monumental heritage to recognition of the living, spiritual heritage of indigenous people and their interconnections with the physical, natural environment. Although Choay (1992) had already remarked on this notion of heritage more than a decade ago, it has not yet been applied widely but mostly by a selection of professionals and specialized institutes in Western countries. Along with broadening our interpretation of cultural heritage, we need to expand our notion of conservation; that is, “conservation as a *social process* that is best seen more inclusively, encompassing the creation of heritage, interpretation and education . . . to acknowledge the importance of social and economic values along with the traditional notions of conservation value, such as age, aesthetics, and historical significance” (Avrami, Mason, and de la Torre 2000: 68–70).

Defining an Emerging Concept

What constitutes a heritage route has not yet been properly described and is an issue in ongoing debates, in particular, by the International Scientific Committee on Cultural Routes (CIIC) of ICOMOS (International Council on Monuments and Sites), UNESCO's advisory body for cultural heritage. This committee developed out of a meeting on the topic of

cultural routes (an early term replaced by *heritage routes*)² held in Madrid in November 1994 following the inclusion of the Pilgrim's Route to Santiago de Compostela on the World Heritage List. The official creation of the CIIC in 1998 was a direct result of the conclusion that more in-depth studies were needed to further the conceptual and operational development of heritage routes. Since 1998, eight international scientific meetings have been held on the topic.

Among the definitions for *cultural route* adopted by the CIIC at its meeting in Tenerife in September 1998 is the following, reported in the conclusions of *Intangible Heritage and Cultural Routes in a Universal Context* (2001):

The concept of a cultural route or itinerary refers to a set of values whose whole is greater than the sum of its parts and through which it gains its meaning. Identification of the cultural itinerary is based on an array of important points and tangible elements that attest to the significance of the itinerary itself. . . . To recognize that a cultural itinerary or route as such necessarily includes a number of material elements and objects linked to other values of an intangible nature by the connecting thread of a civilizing process of decisive importance at a given time in history for a particular society or group.

In principle, it was argued that the definition of *heritage route* should make reference to some key features; as such, a heritage route could be defined as a physical or perceived representation of frequent and repeated movement over a significant period. A heritage route links places in time and space, over land or water or both, or otherwise, and generates, in addition to an exchange of goods and ideas, a cross-fertilization within or between cultural regions of the world.

By this definition, a road would be a physical representation of a heritage route, while a sea lane, for instance, would be a perceived one (as it usually only constitutes a dotted line on a seafarer's map). The 2002 *Operational Guidelines for the Implementation of the World Heritage Convention* referred to heritage routes as “long linear areas which represent culturally significant transport and communication networks.”³ It would be more appropriate to use the term *system*. During a meeting in Madrid on May 30 and 31, 2003, experts and representatives of ICOMOS and UNESCO further agreed that continuity and dynamism—as opposed to the far more static nature of a landscape—are also essential aspects of a heritage route.

Routes as World Heritage: Types and Forms

No clear model exists for the nomination of heritage routes to the World Heritage List. Below I briefly discuss some core aspects of inscribed World Heritage properties with typological and/or physical similarities to heritage routes. Several heritage routes have been inscribed on the World Heritage List. If a road is considered a (segment of a) line, with start and end points, and is of considerable length and limited width, then theoretically a heritage route as a linear nomination constitutes a continuous nomination, where every point along the line is proposed for inscription. The following typology of heritage routes, many of which were inscribed as linear nominations, gives an indication of how this has been applied in practical terms.

1. Transportation (all featured under the category “Industrial Heritage”)
 - Railways*
 - Semmering Railway (Austria, inscribed in 1998): linear nomination, including several properties (mostly villas) along the railway
 - Darjeeling Railway (India, inscribed in 1999)
 - Canals*
 - Canal du Midi (France, inscribed in 1996)
2. Trade Routes
 - Frankincense Trail (Oman, inscribed in 2000): linear nomination, including a serial nomination of four archaeological sites
3. Religious Roads
 - Camino de Santiago (Spain, inscribed in 1993): linear nomination, including several properties along the road
 - Camino de Santiago (France, inscribed in 1998): linear nomination, including a serial nomination with about seventy properties inscribed
4. Linear Monuments (e.g., fortifications/defensive structures)
 - Great Wall (China, inscribed in 1987)
 - Hadrian’s Wall (England, inscribed in 1987): linear nomination, including several properties along the wall
 - Defence Line of Amsterdam (Holland, inscribed in 1996): this property also falls into the canals classification.

A closer look reveals that these have a formal, materialized linear element as their core property, as opposed to a network

or system that perhaps does not necessarily have a physical linear structure as its core (e.g., a maritime route). This rather narrow definition has no doubt limited the identification and nomination of other properties that might have been included under the broader concept of heritage route.

Furthermore, all these routes (including linear monuments) have structures and settlements associated with them. This is most apparent in the following cases:

- Camino de Santiago. This route was inscribed as a linear nomination with a protected 30-meter strip of land on either side of the road. This protection zone broadens out in places to include towns, villages, and buildings that are already protected for their cultural value under Spanish law.
- Semmering Railway. Construction of the 41-kilometer-long railway across the Semmering Pass between 1848 and 1854 led to the creation of a cultural landscape with villas and hotels along much of its route. This is an outstanding example of a sympathetic insertion of buildings of high and consistent architectural quality into a natural landscape.
- Hadrian’s Wall. Almost one hundred monuments are associated with the wall, including forts, ditches, roads, and rampart walks, forming an outstanding ensemble of defensive constructions and settlements in an archaeological zone that is the largest in the United Kingdom.

A proper inventory of the structures and settlements along a route seems essential to establish its nature and the most appropriate inscription: linear (one continuous property), serial (a property consisting of clusters of sites, which can be discontinuous), or mixed. Furthermore, a route cannot be dissociated from its context (e.g., the landscape). Therefore, analysis of ancient and modern topography, using historic maps, is essential for assessing the value of this aspect of the property to be nominated.

Integrity and Authenticity Applied to Heritage Routes

Among the criteria used for the inscription of properties on the World Heritage List are *integrity* (a measure of the wholeness and intactness of the natural and/or cultural heritage and its attributes) and *authenticity* (the value attributed to the heritage, depending on the degree to which information

sources about this value may be understood as credible or truthful). Initially, the condition of integrity was applied primarily to natural sites, and the test of authenticity was reserved for cultural sites. Recently, with the introduction of cultural landscapes, integrity is being applied increasingly to cultural sites. Von Droste zu Hülshoff explains that “the notion of ‘integrity,’ even in its common use referring to ‘wholeness,’ has an ecological basis. Integrity relates to the maintenance of functional relationships between components of a system. When applied to World Natural Heritage Sites, one can describe conditions which are essential for the maintenance of the integrity of particular World Heritage values” (UNESCO 1998: 13). The issue seems relevant to heritage routes as well.

During the 2001 Thematic Expert Meeting on Asia-Pacific Sacred Mountains in Wakayama, Japan, it was determined that integrity implies a balanced state of ecological systems and aesthetic, cultural, religious, or artistic associations. As is the case for sacred mountains, protecting the integrity of heritage routes may need to take into account evolving cultural practices, including traditional ecological, engineering, and construction knowledge; that is, “an enhanced appreciation of the interface between ecology and culture as a dynamic basis for maintaining the integrity” of a heritage route must be considered.

It may be obvious to many that for heritage routes the condition of integrity should apply, but how to deal with the test of authenticity remains a dilemma, since the original function of the route usually has disappeared over time. Nevertheless, this would still leave cultural sites, properties, and natural areas along the route that are of historic and scientific importance, authentic, and worthy of protection and conservation. The current *Operational Guidelines for the Implementation of the World Heritage Convention* (UNESCO 2005) state that the authenticity of a heritage route can be assessed on the grounds of its significance and, moreover, on the duration of the route itself, as well as “the legitimate wishes for development of peoples affected.” What does this mean for heritage routes?

The Asia-Pacific Sacred Mountains Expert Meeting also indicated how authenticity—as defined in the *Operational Guidelines* and the *Nara Document on Authenticity* (UNESCO 1994)—could be applicable to heritage routes: it “should encompass the continuation of traditional cultural practices.” “This authenticity, however, must not exclude cultural continuity through change, which may introduce new ways of relating to and caring for the place.” Furthermore, in order to

determine authenticity and to protect it, one needs to examine closely the distinctive character and components of tangibles, and the associated intangible values, that represent the outstanding universal significance of the heritage route.

Thus applying integrity and authenticity to heritage routes involves the protection and conservation of a series of elements of various natures, incorporating tangible and intangible values, linked by a physical or perceived artifact, like a string of pearls. The pearls, essentially, are significant places of memory that constitute the main story line: they are sites that have outstanding universal value (OUV), the main criterion for World Heritage listing.

The Great Silk Road: Statement of Significance

Many routes of cultural-historical importance have linked great civilizations and thereby shaped world history. As Fernández-Armesto (2001: 71) points out, “Avenues across the Gobi and Takla Makan were part of the web of silk roads that linked the civilizations at either end of Eurasia. . . . Chinese science and technology were diffused across Eurasia partly by maritime routes but also, vitally, via the deserts which the silk roads crossed.”

The global significance of the great Silk Road needs hardly be debated anymore. Indeed, for more than a decade it has been part of the UNESCO project *Integral Study of the Silk Roads: Roads of Dialogue*. In the introduction to *The Silk Roads: Highways of Culture and Commerce*, which contains papers written for conferences held in the context of the UNESCO Silk Road project, Elisseeff explains:

These roads, regardless of how they were called, have been known to humanity for many centuries and, as far as the major routes are concerned, for several millennia. Most of them are the descendants of natural roads following patterns of vegetation whose ecological qualities enabled man and beast to thrive in the days when paleolithic hunters tracked their game. These historical routes are also terrestrial and maritime, running from east to west and corresponding to waterways that run from north to south. They introduced sedentary and nomadic populations, and opened up a form of dialogue between the cultures of East and West. (2000: 2)

Concerning the significance and impact of the Silk Road in China, Elisseeff (2000: 265) states, “Until the last three

hundred years, most of the inventions and technical advances which made a real difference to people's lives came from China—including, most notably, paper, the printing press, the blast furnace, competitive examinations, gunpowder, and—among many critical innovations in marine technology—the ship's compass. Long sustained Chinese initiative depended on the availability of routes of transmission."

Spanning a quarter of the globe, the Silk Road brought not only goods such as silk and spices to the Western world but also objects of gold, glass, and other prized Roman creations to the elite of the Orient. The first route joining the Eastern and Western worlds, the Silk Road may also be given a spiritual identity: along these roads technology traveled, ideas were exchanged, and friendship and understanding between East and West were experienced for the first time on a large scale. Therefore, the importance and value of the Silk Road can be related to the unity it brought about, leading Zekrgoo (2000: 126) to state that "the great Silk Road may be counted as the most important route in the history of mankind."

We can extend this statement and argue that the immaterial aspect of heritage routes is more important than the material, that is, in this case, the Silk Road as a vehicle for cross-cultural exchange. In doing so, Sugio writes:

The present Silk Road is not found to have been preserved in its perfect form up to the present, but the intangible heritage, such as the characteristics of surviving race surrounding the route and the minority race, their figures, the genes, languages, cultural properties, clothing, living styles, agricultural methods, city structures, architectural styles, customs, manners, political systems, religions, traditional skills, industries, arts, music, etc., are continuing distinctly still now. Therefore even though it is not necessarily existing or is preserved as a road in a clear form, its existence and value as a cultural route becomes evident when the existence of intangible heritage is traced back. (2001: 44)

It seems that heritage routes, even more than cultural landscapes, can be considered halfway between tangible and intangible heritage, containing a significant part of each domain.⁴ Therefore, in order to preserve the legacy of the Silk Road in a comprehensive manner, more than just monuments and sites need to be taken into account. In addition to all the elements that would normally be considered in the protection

of cultural landscapes, one fundamental aspect to consider for heritage routes would be elements and aspects related to the *movement of people and goods* (transportation, vistas for orientation, beacons and communication towers, etc.).

It would be more pertinent, therefore, to adopt an approach that recognizes the immaterial and diffuse nature of a heritage route, the dynamic effects of transmission and impact, including all fields of human activity connected to the road, such as politics, commerce, science, religion, and culture. For the Oasis Route in China, in particular, elements and aspects to consider should include oases and agricultural systems, engineering and transportation, caves for shelter and prayer, open landscapes for contemplation and spiritual motivation, vistas for orientation, and resting and trading places with bazaars and caravanserais, but also transit points between different realms of power, such as military garrisons, fortifications, beacons, and communication towers. In this way, a better representation (of values) through significant aspects and elements as part of the nomination can be guaranteed.

China's Oasis Route

In China, the section of the Silk Road known as the Oasis Route stretches roughly 4,450 kilometers from Xi'an in Shaanxi province to Kashgar in Xinjiang Uyghur Autonomous Region. The number of monuments and sites along this route is vast. What follows is a proposal for a systematic approach and reference framework for the identification, nomination, and management of the Oasis Route as a heritage route.

Identification and Nomination

From August 21 to 31, 2003, with sponsorship by the government of the Netherlands, the first of three identification missions took place along the Oasis Route in China, involving Chinese officials from the State Administration of Cultural Heritage (SACH) and staff of UNESCO's World Heritage Centre. The second mission was conducted in July 2004, and the third mission is scheduled for 2006. This ongoing project aims to facilitate discussion on and enhance the understanding of the identification of heritage routes and their nomination to UNESCO's World Heritage List. This effort contributes to an initiative that is foreseen to have a significant impact on current thinking about conservation projects and their operationalization.

While the significance and importance of nominating the Oasis Route to the World Heritage List was clear to

the Chinese authorities (out of the more than eighty sites on China's Tentative List, this was given a priority for nomination), how exactly to proceed in this major endeavor remains a question. The Silk Road nomination initiative is broad in scope, requires substantial resources, and must take into account the long-term planning and complexity of a World Heritage listing. Given this, it is imperative to properly structure the nomination process to avoid a random selection of culturally-historically important places along the Silk Road and in the process lose overview and context.

The nomination effort should be holistic and focus on the identification and justification of those aspects and elements of the Silk Road that will "tell its story" in a comprehensive manner. This means that to understand and appreciate the full dimension of the Silk Road as a heritage route and its cultural-historic significance, a wide variety of elements need to be considered. In addition to the obvious grand sites, perhaps supplementary structures and landscapes should be included. The SACH/UNESCO identification missions took the broadest possible view in their discussions of the inclusion of elements (engineering, military, transportation) in addition to recognizable properties, such as buildings and settlements (living or archaeological sites and ruins). Since abundant research and documentation on the Silk Road exists, what is needed now is the definition of a vision and proper methodology pertinent to the concept of heritage routes. This would call for the repackaging of existing information and a proposed framework to facilitate the preparation of an incremental serial nomination, that is, a phased nomination of a series of clusters of heritage sites linked by and representing the Silk Road.

A reference framework, according to Avrami, Mason, and de la Torre (2000: 10–11), should consist of "a set of theories, documented patterns, and processes that outline cultural-historic significance and identification and presentation of its workings, i.e., the elements and aspects that define the whole," which should be understood as the modeling of the social, economic, and cultural impacts and influences of the Silk Road, "just as ecological models create an understanding of the natural environment to inform natural conservation."

A first step in the nomination initiative for the Oasis Route in China as a heritage route is to finalize a definition of the concept and subsequently to determine the significant elements that constitute a heritage route as applied to the Silk Road. It will then be possible to sketch a broad picture of the meaning and impact of the Silk Road and establish

where essential aspects have coalesced and materialized. This approach should be the focus of the nomination process.

Beyond OUV. As argued above, in defining the significance and value of heritage routes, perhaps it will be necessary to look beyond properties and sites of outstanding universal value and consider other elements that are needed to fully understand and appreciate context and relationships—elements that would give the story more depth and character. Blair and colleagues (2001: 230) argue in this regard that "routes are, *par excellence*, the sum of their parts— . . . no site in isolation perhaps crossing the threshold for heritage listing—but a combination of sites forming a powerful and significant cultural experience." Perhaps the issue is more pertinent and complex. Whereas individual sites *need* to cross the threshold in order to obtain World Heritage status, the protection and conservation of additional elements, which might not necessarily be of OUV, need to be taken into consideration as well. For example, in the case of the Mogao Grottoes (listed as a World Heritage Site in 1987, under Cultural criteria i, ii, iii, iv, v, vi)—obviously one of the grand sites along the Oasis Route in China—it may be pertinent to include elements that initially seem to have little to do with the Buddhist art in the caves. Thus in order to preserve the memory of the Oasis Route, references other than the wall painting depictions, such as those at cave 103 showing Xuan Zang's journey to India traversing the Pamirs in search of Buddhist scriptures (Whitfield, Whitfield, and Agnew 2000: 25), should be maintained.

More and more heritage sites in the world, certainly in China, are becoming detached from their original settings and meanings, as governments try to maximize development opportunities and in the process isolate sites. When twenty years from now the access road to Mogao has been turned into a circus fair, with high-rise hotels, restaurants, service stations, and perhaps a whole new town, what remains of the experience of a formerly remote desert site attached to an oasis along a trade route? The oasis is gone, the trade route is gone, and the desert landscape is visible only in the far distance. The immediate experience is one of modernization and comfort. Thus there is a need to establish a wide perimeter around the core zone where references to the oasis, trade route, and remote location are maintained.

While the caves' extraordinary collection and quality of Buddhist art that came to China along the Silk Road are unquestionable, and indeed of OUV, it can be argued that the site gains even more significance if one properly understands the conditions under which this magnificent art was

produced, by whom, where, and why. Imagine artist-monks in an oasis, providing a safe haven, both physically and spiritually, to travelers at a remote location along the Silk Road in the incredibly harsh environment of the Takla Makan, one of the most fearsome deserts in the world: all these elements constitute an essential contribution to appreciating this site to the fullest. The Mogao Grottoes site thereby gains even more value. Indeed, this context constitutes one of the intangible values of the site.

With the current pace of development everywhere in China, there is a serious danger that soon only the formal World Heritage Site will remain (i.e., the caves with Buddhist art) and that its context and relationship with the Silk Road will be understood only through a one-line mention in a presentation brochure. The physical experience of visiting a remote site—an important aspect of the encounter—will have disappeared if visitors arrive at the site by driving through a modern city, stepping from an air-conditioned car into an air-conditioned interpretation center and then immediately onto the site; they will not even know that they are in a desert. In practice, this means that, in addition to the caves themselves, this World Heritage Site should be expanded to include areas associated with the caves and that this expanded site should be protected, managed, and presented to provide the fullest possible setting. This expanded area would encompass the oasis, with unobstructed vistas into the surrounding desert through which the ancient Silk Road once passed. In other words, this expanded site would be part of a Silk Road heritage route. Any kind of development should be located outside a wide perimeter around this expanded heritage site.

“*Borrowed scenery.*” Beyond the intangible aspects of cultural heritage, physical setting is a factor that is receiving increasing attention. For heritage routes, this seems of particular importance because in principle they were formed or guided by geologic formations as they crossed natural and cultural landscapes. In this regard, a concept that could be of use in defining cultural sites in their context and setting, and the extent of their significance in direct relationship to a heritage route, would be *shakkei*, or borrowed scenery. *Shakkei* is used in Japanese garden design as “a technique for enlarging the visual scale of the garden beyond its actual physical boundaries by incorporating a distant view as an integral part of the garden” (Keane 1996: 140). Borrowed scenery was an important technique in the planning and design of Chinese gardens as well, where not only could scenery be borrowed, but forms, sounds, colors,

and fragrances were also incorporated into gardens (Liyao Cheng 1999: 135).

The importance of the surrounding landscape in the context of the Silk Road becomes apparent when one realizes that silk, as a commodity in ancient times, was so highly valued precisely because of the hardships merchants had to endure to bring it to the markets in the West. As Bonavia and colleagues write, “The early trade in silk was carried on against incredible odds by great caravans of merchants and animals travelling at a snail’s pace over some of the most inhospitable territory on the face of the earth—searing, waterless deserts and snowbound mountain passes. . . . Blinding sandstorms forced both merchants and animals to the ground for days on end . . . and altitude sickness and snowblindness affected both man and beast along cliff-hanging and boulderstrewn tracks. Death followed on the heels of every caravan” (Bonavia, Lindesay, and Wu Qi 2002).

For the Chinese section of the Silk Road, in particular, around the Takla Makan, the oasis towns therefore were of paramount importance, as they allowed the caravans to make and survive the overland journey. Very few caravans, including the people, animals, and transported goods, completed the entire route that connected Rome and Xi’an, the capitals of the two great empires. The oasis towns provided the caravans with fresh merchants, animals, and goods and became important trading posts and commercial centers. In light of this, preserving the urban and architectural heritage of these towns alone would not allow comprehension of their significance—even if the towns were of outstanding universal value. Preserving the traditional agricultural practices and supportive engineering structures that provided for water, for instance, would be *at least* as important in telling and understanding the story as the towns themselves: one could say that the expanded context constitutes “borrowed scenery.”

Anchor sites versus support sites/structures. For the purposes of identifying heritage routes, it is advisable to distinguish between anchor sites and support sites or structures. Anchors would be those sites considered to have outstanding universal value; support sites or structures do not necessarily possess OUV but are nevertheless an important complement to the picture. Support sites or structures will therefore have to be connected, physically and/or conceptually, as a cluster to the anchor sites. With regard to protection, conservation, and management of both anchor sites and support sites or structures, however, there should be little distinction: they deserve equal care and resources to guarantee their preservation for future generations.

Management

Establishing a national management unit would be an appropriate way to oversee and guarantee high and consistent levels of management of the Oasis Route as a heritage route, which would consist of clusters of heritage sites along the road's more than 4,000-kilometer length. Given China's centralized structure, this would be easy to achieve. Such a national management unit could be entrusted with the classification of the different site clusters, which could be divided according to their main themes: Art (Buddhist, Islamic, other), Architecture (temple, urban, vernacular), Archaeology (cities, monuments), Religion (temples, mosques, meeting points), Military Engineering (garrison stations, forts, walls, towers), Agriculture, Trade, and Manufacture (farming, hydraulic systems, markets, caravanserais), Travel and Transportation (engineering structures, resting places, orientation beacons), and so on. This division could also include combinations of several themes. Identification and management of properties and sites according to these themes would allow for a broad spectrum and subsequent representation of important aspects related to the Silk Road.

Laws and management practices should be uniform for all site clusters. However, separate conservation management plans should also be prepared for each cluster, according to its characteristics and associated values (both tangible and intangible), with a clear division into anchor and support sites. The national management unit would supervise preparation of plans and enforcement of laws for all clusters in accordance with the highest international standards. In addition, local teams would be responsible for the conservation management plan for individual site clusters to ensure the inclusion of regional or local characteristics and practices, as well as to facilitate communication and community participation.

Over time and when more information and resources become available, decisions can be made at the national level to extend sites or include other sites on the heritage route, actions that would significantly enhance the picture of the Silk Road in China. This is something that would be difficult to achieve on a decentralized regional level. Furthermore, tested and tried concepts could be further developed in association with neighboring countries that are considering connecting their most significant Silk Road sites to those in China, thus creating a single, multinational Silk Road heritage route.

For this reason, the third Silk Road identification mission in 2006 by representatives of China's State

Administration of Cultural Heritage and UNESCO's World Heritage Centre will involve the road's central Asian stretch into India, Kazakhstan, Kyrgyzstan, and beyond. Ultimately, this endeavor should result in an incremental, multinational, transboundary serial nomination of the Silk Road Heritage Route to the World Heritage List. The aim is to protect the Silk Road from Xi'an in China to the coastal regions of the Mediterranean Sea in a phased process of incorporating several clusters of properties, sites, and landscapes, both cultural and natural, that are linked by a shared vision and set of values and whose protection is formalized by unified conservation approaches and management plans. All this would be done according to the pace of the various countries involved.

Conclusion

Heritage routes are the latest development in a trend to expand the scale and complexity of heritage properties. Heritage routes require a holistic approach and a new framework for conservation that will foster understanding and serve as a tool for informed decision making.

Beyond the intangible aspects of heritage routes, their physical setting should be taken into account because in principle the routes were formed, or guided, by geologic formations and crossed natural and cultural landscapes. Traditional land-use and land management practices, which have ensured the long-term protection of sites, should be taken into consideration as well when planning protection and conservation activities. Emerging from this view of heritage routes is a combination of anchor sites and support sites or structures that would allow a full understanding and appreciation of context and relationships. There would be little distinction between the two types of sites, as all would need to be protected and managed to guarantee their preservation for future generations.

Laws and management tools should be uniform for all heritage site clusters that are part of a heritage route, and these should be supervised from a national level. However, separate conservation management plans should also be prepared for individual clusters, taking into consideration unique characteristics and associated values (both tangible and intangible) of the sites. Individual, local management teams would be responsible for these plans. This approach would guarantee the inclusion of regional or local characteristics and practices in the management plans and facilitate community participation in the protection of the sites.

In terms of the Silk Road (Oasis Route) in China as a heritage route, only those sites that will explain and present the road in a comprehensive manner should be the focus of identification, protection, and conservation efforts. A Chinese section of the Silk Road heritage route would require the inclusion of a wide variety of elements that relate to the movement of caravans with people and goods, not just the obvious “grand sites.” Furthermore, different clusters of monuments, sites, and landscapes could be identified according to main themes or a combination of several themes. Over time Silk Road sites in other countries could be included, extending the heritage route beyond China and linking its elements with a shared vision and set of values that will preserve for future generations the extraordinary legacy of the Silk Road.

Acknowledgments

The author would like to thank Jing Feng of the Asia-Pacific Unit of the World Heritage Centre, whose assistance has been invaluable.

Notes

- 1 The Silk Road is divided into three sections—the Steppe Route, the Oasis Route, and the Maritime Route (Elisseeff 2000: 13). This paper deals primarily with the Oasis Route in China, although the other routes also exist in and beyond China.
- 2 Although the term *cultural routes* was initially used by the CIIC, it was not accepted because it was considered too restrictive. Preference was given to the term *heritage routes*, which would also apply to routes linking natural heritage sites.
- 3 This reference appeared in par. 40 of the 2002 document but was taken out of the 2005 version.
- 4 See also the definition of *Intangible Cultural Heritage* in article 2 of the *International Convention for the Safeguarding of the Intangible Cultural Heritage* (UNESCO 2003).

References

- Avrami, E. C., R. Mason, and M. de la Torre. 2000. *Values and Heritage Conservation: Research Report*. Los Angeles: Getty Conservation Institute.
- Blair, S., N. Hall, D. James, and L. Brady. 2001. Making tracks: Key issues about the heritage of Australian routes and journeys. In *El patrimonio intangible y otros aspectos relativos a los itinerarios culturales: Congreso Internacional del Comité Internacional de Itinerarios Culturales (CIIC) de ICOMOS . . . Pamplona (Navarra, España), 20–24 junio, 2001 = The Intangible Heritage and Other Aspects of Cultural Routes = Patrimoine intangible et autres aspects relatifs aux itinéraires culturels*, ed. International Council on Monuments and Sites, 227–33. Pamplona: Gobierno de Navarra.
- Bonavia, J., W. Lindesay, and Wu Qi. 2002. *The Silk Road: From Xian to Kashgar*. 6th ed. Hong Kong: Odyssey, Airphoto International.
- Choay, F. 1992. *L'allégorie du patrimoine*. Paris: Editions du Seuil.
- Elisseeff, V., ed. 2000. *The Silk Roads: Highways of Culture and Commerce*. New York: Berghahn Books; Paris: UNESCO Publications.
- Fernández-Armesto, F. 2001. *Civilizations: Culture, Ambition, and the Transformation of Nature*. London: Pan.
- International Council on Monuments and Sites, ed. 2001. *El patrimonio intangible y otros aspectos relativos a los itinerarios culturales: Congreso Internacional del Comité Internacional de Itinerarios Culturales (CIIC) de ICOMOS . . . Pamplona (Navarra, España), 20–24 junio, 2001 = The Intangible Heritage and Other Aspects of Cultural Routes = Patrimoine intangible et autres aspects relatifs aux itinéraires culturels*. Pamplona: Gobierno de Navarra.
- International Council on Monuments and Sites (ICOMOS) and Second International Congress of Architects and Technicians of Historic Buildings. 1964. *The Venice Charter: International Charter for the Conservation and Restoration of Monuments and Sites*. Web page. www.international.icomos.org/e_venice.htm.
- Keane, M. P. 1996. *Japanese Garden Design*. 1st ed. Rutland, VT: C. E. Tuttle.
- Liyao Cheng. 1999. *Ancient Chinese Architecture: Private Gardens*. Wien: Springer.
- Sugio, K. 2001. Intangible heritage and cultural routes in a universal context. In *El patrimonio intangible y otros aspectos relativos a los itinerarios culturales: Congreso Internacional del Comité Internacional de Itinerarios Culturales (CIIC) de ICOMOS . . . Pamplona (Navarra, España), 20–24 junio, 2001 = The Intangible Heritage and Other Aspects of Cultural Routes = Patrimoine intangible et autres aspects relatifs aux itinéraires culturels*, ed. International Council on Monuments and Sites, 43–46. Pamplona: Gobierno de Navarra.
- UNESCO. *Report of the World Heritage Global Strategy Natural and Cultural Heritage Expert Meeting, 25 to 29 March 1998, Theatre Institute, Amsterdam, The Netherlands*. WHC-98/CONF.203/INF.7. Paris: UNESCO. <http://whc.unesco.org/archive/1998/whc-98-conf203-inf7e.pdf>.
- . 1994. *Expert Meeting on the “Global Strategy” and Thematic Studies for a Representative World Heritage List, UNESCO Headquarters, 20–22 June 1994*. WHC-94/CONF.003/INF.6. Paris: UNESCO. <http://whc.unesco.org/archive/global94.htm>.

- . 1994. *Nara Document on Authenticity. Experts Meeting 1–6 November 1994*. WHC-94/CONF.003/INF.008. Paris: UNESCO. <http://whc.unesco.org/archive/nara94.htm>.
- . 2001. *Report of the Thematic Expert Meeting on Asia-Pacific Sacred Mountains, Wakayama, Japan, 5 to 10 September 2001*. WHC-01/CONF.208/INF.9 Rev Paris, 16 December. Paris: UNESCO. <http://unesdoc.unesco.org/images/0012/001265/126500e.pdf>.
- . 2003. *Convention for the Safeguarding of the Intangible Cultural Heritage, Paris, 17 October 2003*. MISC/2003/CLT/CH/14. Paris: UNESCO. <http://unesdoc.unesco.org/images/0013/001325/132540e.pdf>.
- . 2005. *Operational Guidelines for the Implementation of the World Heritage Convention*. WHC. 05/2 2 February. Paris: UNESCO. <http://whc.unesco.org/archive/opguide05-en.pdf>.
- Whitfield, R., S. Whitfield, and N. Agnew. 2000. *Cave Temples of Mogao: Art and History on the Silk Road*. Conservation and Cultural Heritage. Los Angeles: Getty Conservation Institute and the J. Paul Getty Museum.
- Zekrgoo, A. H. 2000. The spiritual identity of the silk road: A historical overview of Buddhism and Islam. In *The Silk Roads: Highways of Culture and Commerce*, ed. V. Elisseff, 318–28. New York: Berghahn Books; Paris: UNESCO Publications.

PART TWO

Policy and Principles



The Content and Theoretical Significance of the Principles for the Conservation of Heritage Sites in China

Jin Hongkui

Abstract: *In October 2000, at the city of Chengde, Hebei province, the Principles for the Conservation of Heritage Sites in China (the China Principles), which includes Commentary on the Principles, was approved by China ICOMOS. This paper presents the main content of the China Principles and the theoretical significance the document has for the conservation of China's cultural heritage sites. It provides a synopsis of and defines the scope of the document's thirty-eight articles, which address a range of conservation issues, and reviews the evolution of heritage preservation in China from the 1930s onward, including the roles of significant historical figures such as Liang Sicheng and Qi Yingtao. In addition, this paper discusses the relationship of the China Principles to the Law of the People's Republic of China on Protection of Cultural Relics and to international practice and conventions, including the Venice Charter and the UNESCO Convention Concerning the Protection of the World Cultural and Natural Heritage (1972). It concludes that the China Principles, along with their Commentary, present an organized, systematic compilation of Chinese experience and draws on domestic and international success to provide operational guidelines. It is believed that such guidelines are highly significant for the development of an urgently needed theoretical base to guide practice in the conservation of China's immovable heritage.*

The *Principles for the Conservation of Heritage Sites in China* (the China Principles) was published at Chengde, Hebei province, in October 2000. In the afterword, Zhang Bai, deputy director-general of the State Administration of Cultural Heritage, details the reasons for and the process of drafting the document. This paper summarizes the main contents and the theoretical significance of this document for

Chinese conservation practice. The China Principles consist of thirty-eight articles addressing a range of conservation issues, Commentary on the Articles, and an English-Chinese glossary of conservation terms.¹

Key Articles of the China Principles

Article 1 states: "Heritage sites are the immovable physical remains that were created during the history of humankind and that have significance; they include archaeological sites and ruins, tombs, traditional architecture, cave temples, stone carvings, sculpture, inscriptions, stele, and petroglyphs, as well as modern and contemporary places and commemorative buildings, and those historic precincts (villages or towns), together with their original heritage components, that are officially declared protected sites."

Article 24 states: "Natural and cultural landscapes that form part of a site's setting contribute to its significance and should be integrated with its conservation."

Article 36 states: "These *Principles* may also be drawn upon for conservation of the historic condition and setting of commemorative places where important historic events took place."

In the *Management Regulations for Memorial Sites, Ancient Buildings, and Rock Grottoes*, issued in 1986 by the Ministry of Culture, the objects of protection were expanded from ancient buildings to all immovable heritage. This accorded with the actual situation of China's cultural heritage protection. In recent years, great efforts have been made to preserve, by means of advanced technology, the historic sites, particularly those of large scale: ancient tombs, ancient villages, and historic streets, some of which are key state

projects. The expansion also reflects the developing concept that although the heritage objects are diverse in form and scale, they should be preserved in accordance with common principles once they have been designated as heritage.

Purpose and Objectives of the China Principles

Article 2 states that the purpose of the China Principles is to ensure preservation, through good conservation practice, of the authenticity of sites and their information and values. The objectives are to remedy damage done by natural and human forces and to prevent further damage, by both technical means and managerial measures. This is, significantly, the first time in China that the purpose of cultural heritage protection has been defined from the perspective of preserving and sustaining authenticity and historic information. Realization of this point constitutes the core of protection work and is the very basis of the China Principles.

The Threefold Value of Cultural Heritage Sites

Article 3 states that the value of a heritage site is threefold: historic, artistic, and scientific. Chapter 2 of the Commentary analyzes in detail these values and concludes that cultural heritage must retain its historic authenticity. Based on this concept, article 2 states, “All conservation measures must observe the principle of not altering the historic condition.” This article is in accord with the Law of the People’s Republic of China on Protection of Cultural Relics, which decrees that “the restoration, maintenance and relocation of immovable heritage shall be carried out in such a way that the original look of the relics be maintained.”²

Articles 18 through 27 set forth the technical requirements to ensure that the original condition of a site is kept intact.

Heritage Conservation as a Systematic Process

Article 2 states, “Conservation refers to all measures carried out to preserve the physical remains of sites and their historic settings.” This means that conservation not only involves construction work or refurbishing and restoration of ancient buildings in the common sense of the words, but is also guided by principles that are unique in this field. Article 5 further points out, “Conservation needs to be carried out according to a sequential process,” the phases of which are elaborated in articles 9 through 17 and in chapter 5 of the Commentary. The China Principles also relates conservation to daily management. Defining the technical phases of the

protection work as a logical process is one of the unique and important innovations of the document.

Assessment of Significance

Article 5 states that in the entire process of cultural heritage protection, assessment of the values of a site is the top priority. Article 12 states that the result of the values assessment is the basis for determining the level of classification as an officially protected entity, and article 13 states that the assessment result is also the basis for formulating the site’s conservation master plan. Chapter 8 of the Commentary elaborates the main contents of the values assessment.

Stages of Conservation

Articles 13 through 16 elaborate the three stages in developing and implementing a site’s conservation master plan: formulation, execution, and review. Chapter 9 of the Commentary states, “All heritage conservation organizations should draw up a conservation master plan” and explains the types of master plans and the main contents of each type.

Use of Heritage Sites

Article 4 states that cultural sites should be used in a rational manner, that this use is for social benefit, and that no damage to the site’s values shall be inflicted for short-term gain. The Law of the People’s Republic of China on Protection of Cultural Relics, as revised in 2002, decrees that “protection is the purpose, remedy of the damage is of top priority, [and] reasonable use and efficient management are fundamental.” This means that the three tasks of heritage preservation—namely, conservation, use, and management—are of similar importance and that none shall be neglected. Of the three, conservation is the basis for deciding use, which is secondary and must be guided by the requirements of conservation. Management involves the whole process and should therefore be promoted. The China Principles also proposes standards for reasonable use of sites. Chapter 4 of the Commentary elaborates the relationship between the social benefit and the financial benefit derived from use of a site.

Conservation Interventions

Articles 28 through 35 state that conservation includes all technical measures taken to repair a cultural site and improve the surrounding environment. They define the concepts and technical measures for conservation work according to six types: daily maintenance, prevention and stabilization, improvement of present condition, focused remedy of seri-

ously damaged condition, restoration of the whole site, and environmental management. Chapters 11 through 16 of the Commentary recommend technical measures to be taken and problems that may occur in the work.

Theoretical Significance of the China Principles

As analyzed above, the China Principles constitute a document rich in content and logically coherent among its Articles and Commentary chapters, and they provide both principles and practical procedures concerning conservation techniques and management. It is a document formulated by an independent collaboration of scholars working in the conservation field, framed within China's relevant laws and regulations. The China Principles are both a summary of seventy years of experience accumulated by Chinese conservation practitioners and a reflection of the achievements resulting from increasing exchanges, in both theory and practical work, with international conservation counterparts. In short, the China Principles are of vital significance in establishing a theoretical framework for China's cultural heritage protection.

The vast body of experience and research results acquired by architects, archaeologists, historians, art historians, management, and others whose activities have related to the preservation of China's cultural heritage is highlighted below.

Clarification of the Objectives and Specific Tasks of Conservation

At the beginning stages of cultural heritage protection in China, attention was paid only to the maintenance of ancient buildings, to their history and original appearance, and, if possible, to extending their life. An example of this approach is found in the 1932 Plan for the Reconstruction of the Floor, Beams, and Girders of Wenyuan Ke, which states that "artistically, the top priority is to maintain the original look" (Tsai Fangyin, Liu Tuntseng, and Liang Sicheng 1932). Later, in the 1934 Plans for the Restoration of the Wanchun Pavilion, the approach was expanded to include architectural elements and amended such that "all newly applied painting should look as much like the original as possible" (Liu Tuntseng and Liang Sicheng 1934).

In the 1950s the Mogao Grottoes were included in the range of cultural heritage needing protection, and the values of the cultural relics were defined as revolutionary, historic, and artistic. As stated by Chen Mingda ([1953] 1998: 16), "Any

historical construction that exists today, once its historic and artistic values are confirmed, is to be protected with the greatest possible effort."

Since the 1960s the values of cultural property have been legally recognized as "historic, artistic, and scientific." The purpose of preserving ancient buildings was defined as "making the past serve the present"; that is, ancient relics are to be used as a means to educate people about the history of China and to cultivate their aesthetic awareness. Specifically, there were four purposes for preserving ancient buildings: (1) to motivate the Chinese people's patriotism and national confidence; (2) as material evidence for historical studies; (3) as inspiration for architectural and artistic innovations; and (4) as recreational and tourist facilities. The second of these was viewed as the most significant, and it is commonly known as preserving "historic values" (Qi Yingtao [1985] 1992: 171). Since the 1990s the range of types of cultural heritage to be protected has been greatly expanded.

Development of Concepts of Heritage Conservation

Two conservation principles followed in China in the 1930s were to maintain the present condition of ancient buildings and to restore them to their original appearance (Liang Sicheng 1935: 1). In the 1950s the principle was shifted to preservation of the original appearance, which applied to both the exterior and the interior of buildings: "The restoration of ancient buildings shall preserve their historic form, structure, and all decorative patterns. This is what the Ministry of Culture decreed: preservation of the original form. The preservation of the original form applies not only to the visible exterior but also to the invisible interior" (Chen Mingda [1953] 1998: 17–18).

These concepts, since they were intimately related to practical preservation work, were challenged by the problems incurred as the work deepened and expanded. As a result, experts had numerous discussions concerning the conservation approaches, and the consensus reached covered the following issues:

1. *Preservation of the existing condition, restoration of the original form, and maintenance of the original appearance.* The Provisional Statute for Cultural Heritage Protection of the State Council (1961) decreed that the restoration and maintenance of ancient buildings and grottoes, including any later additions, should be guided by the principle that the original form should be restored or the present

condition preserved and that the institutions that make use of the heritage sites for tourism or educational purposes should make no alterations to the original form.

The Law of the People's Republic of China on Protection of Cultural Relics, originally enacted by the Chinese People's Congress in 1982, decreed that the restoration, maintenance, or relocation of revolutionary sites, memorial buildings, ancient tombs, ancient grottoes, and ancient engravings and their attachments are to be guided by the principle that no alterations should be made to their original form and that the institutions making use of heritage property for other purposes should conform to the same principle and ensure that no damage, removal, replacement, or addition be done.

These two clauses provide evidence that a consensus was taking the form of conservation principles. Controversies over such questions as the present condition of cultural heritage and what should be preserved were essentially settled in the early 1980s: "The preservation of the present condition means the preservation of the healthy look of ancient buildings as they are at present. It would be wrong to think that preservation of the present condition means the preservation of a shabby mess" (Qi Yingtao [1981] 1992: 125).

Another controversy lies in the concept "original form" and how it might be restored. With regard to a building, the definition at present is the form it had at the time of its identification as a place of historic value, not necessarily the form it might have had at its earliest historic period. The criteria for determining original form result from the time of authentication of the existing remains. Accordingly, restoration to the original form is also determined by authentication of the original form.

The actual time of a building's construction and the corresponding characteristics are to be used as the basis for restoration (Qi Yingtao [1985] 1992: 171). Restoration of the original form should be based on the fact that the major parts of the building, that is, the wooden framework consisting, for example, of beams, and brackets, exist with only minor parts lost or damaged (Qi Yingtao [1987] 1992: 346). It should also be based on the premise that "the people who are responsible for the restoration must have adequate proof and evidence for the original form of the building" (Liang Sicheng 1932) and that "full investigation has to be conducted to determine the original form, and adequate expertise, technology, and financial support should be mobilized

before the work begins" (Qi Yingtao [1985] 1992: 170). In the choice between preserving the present condition of a building and restoring the original form, the consensus is that the first consideration should be preserving the present condition, since restoration of the original form is too complicated a task to accomplish with assurance. In fact, in many cases, preservation of the present condition is the only alternative.

By "no alterations to the original form" is meant "both of the two alternatives" (Qi Yingtao [1985] 1992). Therefore, for ancient wooden buildings, conservation is the highest objective to strive for, and preservation of current condition is the basic requirement (Du Xianzhou 1986).

2. *Preservation, to the greatest extent possible, of the remains of the ancient buildings.* One of the contributions that architects of the 1930s made to the preservation of China's cultural heritage was the introduction of architectural, structural, and engineering knowledge into the area that had once been the domain of craftsmen only. The architects were, however, ignorant of the significance of preserving the conventional techniques and materials from which the ancient buildings had been constructed. Rather, they believed in reinforced concrete as an ideal substitute for wood in both reparation and restoration work (Liang Sicheng 1935a: 1).

In the 1960s experts started to consider the feasibility of using traditional techniques and wood to replace damaged or decayed wooden parts, and this idea was successful in the restoration of Yongle Gong (Palace of Everlasting Happiness). In the 1970s synthetic materials as reinforcing agents were tried so as to minimize replacement of original parts, and it was at this time that the maximal preservation of the original form of ancient buildings started to draw professional attention. Qi Yingtao summarized this approach in 1985: "For individual buildings, the original form that we try to preserve includes the following four aspects: shape, structure, texture, and craftsmanship. For compound buildings, one more aspect should be added to the list, that is, the interior and the exterior environment that the buildings had at the time of construction" (172). Luo Zhewen ([1990] 1998: 258–60) summed up the concept of original form of ancient buildings at the UNESCO Asian and Pacific Cultural Heritage Protection Conference in 1990 as follows: shape, structure, material, and technique.

3. *Restoration of the old as old.* This concept was first suggested, possibly in 1952, by Liang Sicheng. According to Luo Zhewen's memoirs, Liang said, "Restored ancient buildings should have the ancient flavor. In other words, the old should be restored as old" (Luo Zhewen 1998: 301). Chen Mingda ([1953] 1998: 19) stated similarly, "To renovate ancient buildings without careful study, to lose the detailed craftsmanship and tone of the artist and thus lose the original look, is not restoration at all; it is destruction." In 1964 Liang Sicheng elaborated this idea: "I still believe it to be an absolute diminishment of artistic and historic values to turn ancient buildings into something brilliantly new, like polishing vessels of the Zhou dynasty and mirrors of the Han dynasty to re-create their shining surfaces. . . . I think we need to conform to the principle of restoring the old as old in the preservation of ancient buildings that carry historic and artistic values" ([1964] 2001: 440–42). Qi Yingtao has stated on many occasions that "to restore the old as old" is not only aimed at the external effect of the restoration work but is also a technical methodology. For example: "In the course of ancient building restoration, whether to restore the original form or to preserve the present condition, the ultimate effect, in addition to stabilization, should be the obvious signs of its age, the markings of time, so that the viewer may get an immediate glimpse of the longevity of the building. To achieve this effect, we should analyze the color, the luster, as well as the structural features of the building. . . . And it can be accomplished by combining various factors which we call 'to restore the old as old'" (Qi Yingtao [1978] 1992: 125).
4. *Reconstruction of destroyed buildings.* Mainstream opinion is generally against this concept. Chen Mingda ([1953] 1998: 16) has written, "Some important buildings that were destroyed in the past but found their way into historical documents may provide no clue at all about their original shape, and there is, of course, no way of maintaining their historic and artistic value. For such cases, there is no need to consider reconstruction."
5. *Other concepts.* With increasing international exchange in the field of cultural heritage protection

in the 1970s and 1980s, some experts, Qi Yingtao among them, suggested other principles that we need to conform to. The reversibility principle states that "strengthening measures should be reversible to some extent"; the minimum interference principle states that "if minor repair is adequate, do not make major repairs; if partial removal is satisfactory, do not completely remove; original parts should be preserved to the greatest possible degree; the extent of repair should be limited to the smallest possible area; and replacement should be applied to as few parts as possible" (Qi Yingtao [1985] 1992: 182–83). The legibility principle states that "repair work that is aimed at preserving the present condition should guarantee that the signs and markings of previous repair work be preserved so that these successive traces may serve as evidence in diachronic studies of the architectural characteristics of other dynasties. In other words, the markings may carry a considerable degree of legibility" (Qi Yingtao [1988] 1992: 354). All these concepts have been generally accepted and adopted in practical restoration work.

Establishment of Cultural Heritage Conservation and Restoration Procedures

In 1935 Liang Sicheng formulated the Plan for the Restoration of the Buildings in the Confucius Temple at Qufu. In the preface, Liang wrote, in reference to the differences between modern designers and the ancient architects: "We need to be responsible for the conservation or restoration of the ancient buildings from various dynasties. We need to acquaint ourselves, before designing, with the date of construction, the architectural style of the time and the cause of the damage, if any, to the buildings and its remedy" (1935b). Liang's practice in the restoration of the Confucius Temple established a procedure that has been refined and that is still in use today.

Clarification of the Relationship between Conservation and Use of Cultural Heritage

From the beginning China was faced with the problem of how to make use of its cultural heritage. In the 1950s it was urgent to find new functions for ancient buildings, and the idea of assigning new functions to ancient buildings based on categorization according to their importance was

proposed. In 1952 Luo Zhewen classified immovable heritage generally into two categories: unsuitable and suitable for practical uses. The former included stone engravings and sculptures, statues, and other relics of archaeological value but no practical utility, and the latter included, according to Luo, “(1) Those important ancient buildings that can serve as museums, exhibition venues, parks and tourist resorts, etc., the use of which must be guided by the noninterference principle; and (2) those ancient buildings of minor importance that can serve as offices, schools, meeting rooms, etc., the use of which is again guided by the principle that no damage is done to the buildings themselves and the major components such as the main halls of temple complexes, stele, sculptures and engravings, etc.” ([1952] 1998: 161–64). Chen Mingda, in 1955, pointed out that “in some places, protection is mistaken for no function; that is, the buildings are completely locked up. The lack of restoration and financial support thus isolates them, and gradually they fall into decay” ([1955] 1998: 71). In the 1980s Qi Yingtao said that “ancient buildings and other cultural relics inside a protected site should first be classified into several categories and then put to different uses according to their values.” Newly constructed service facilities should “not interfere with the view,” and newly constructed tourist attractions should “go with the original buildings in style and nature,” and there must be “a border between the relics and the new constructions” ([1984] 1992: 166–67).

Categorization of Heritage Conservation Projects

Cultural heritage preservation is the main task of conservation work. Because of the immovable nature and the materials, mainly wood, of buildings, such projects are complex and diverse. To protect the heritage from further decay, it is vital to categorize the project and to clarify each category. In 1953 Chen Mingda classified projects into four categories—maintenance, rescue, reinforcement, and restoration—and clarified the objectives, targets, methodology, procedure, and problems of each. Conservation practice over the past fifty years has for the most part conformed to his categorization.

International Cooperation as Reflected in the China Principles

Compared to Europe’s, China’s cultural heritage protection had a late start. Its growth, however, has always been facilitated by assistance from other countries. The earliest law concerning heritage protection is the Law for the Preservation of

Ancient Relics and its Implementation Specifications published by the government of the Republic of China in the 1930s. Lu Zhou (2001) wrote, “The whole law and most of its regulations are borrowed from foreign countries,” adding that pioneer specialists, such as Liang Sicheng and Liu Dunzhen, favored introducing, studying, and adopting the practices of Europe and Japan.

In the 1950s the Chinese authorities decreed that practices in the Soviet Union should be adopted (Wang Yequi [1957] 1997). Soviet laws and academic works were quickly translated into Chinese for reference. In summary, the Soviet system contained the following points: (1) all cultural and artistic heritage of a country belongs to the people and should be under the direct control of the state, and the preservation of the heritage is of great significance to the whole nation; (2) the state formulates all laws to regulate protective actions, and the work should be carried out by specialized government agencies; (3) a special institution is established in the government (the People’s Committee) to take charge of protection work, and similar institutions are set up in the governments of all federal republics; and (4) the documentation, registration, maintenance, and repair of memorial buildings (i.e., heritage properties) should be standardized (Luo Zhewen [1953] 1998, [1955] 1998). Soviet practices played a fundamental role in the formulation of China’s legal and administrative systems.

With the implementation of its open policy, China moved faster to catch up with the rest of the world in protecting cultural heritage. China’s ratification of the UNESCO Convention Concerning the Protection of the World Cultural and Natural Heritage in 1985 indicated that its heritage protection had become part of the global effort. All related agreements and charters of UNESCO were translated into Chinese, professional exchanges between China and other countries became increasingly frequent, and joint efforts were made in the protection of historic relics. Chinese scholars published books and papers introducing Western practices and theories, which in general influenced the entire nation in cultural heritage protection. The China Principles reflect the country’s continuing efforts at international cooperation and exchange.

The Value of Heritage Protection

The value of historic heritage lies in the fact that relics carry information of the past, a unique civilization, a meaningful development, or a historical event. Ancient buildings and

gardens also reflect the aesthetics of the ancient people and thus have artistic value. Historic sites include not only individual buildings but also whole cities or villages that carry the same values.

Cultural Heritage Values

The British expert Sir Bernard Feilden (1982: 6) summed up the values of cultural heritage as *emotional value*, which includes curiosity, identity, continuity, spirituality, and symbolism; *cultural value*, which includes documentation, history, archaeology, aesthetics, architecture, ecology, and science; and *use value*, which includes functional purposes, such as economic benefit, and sociological and political purposes. Wang Ruizhu's (1993: 6–8) interpretation expands on Feilden's: "Historic buildings and relics carry information handed down from past times, and are truthful vehicles of historical records. They are therefore very important in both historical studies and archaeology. They also afford substantial evidence that contributes to national identity. Important heritage can sometimes serve as the symbol of a nation and thus has spiritual function. The everlasting memory that ancient relics carry may provoke nostalgia for the glorious past of a nation and thus inspire feelings. Craftsmanship and artistry can provide aesthetic experience and inspiration and therefore have great artistic values." These statements on cultural heritage encompass the inherent historic, artistic, and scientific values, as well as the functions they have in educating contemporary society. They therefore serve as guidelines in the practical work of heritage conservation.

Emphasis on Scientific Methodology

Scientific methodology starts with thorough and multidisciplinary research work prior to the conservation project itself. The restoration process is a highly specialized one, aimed at the preservation and exhibition of the aesthetic and historic values of the cultural heritage and based on the original remains and substantial documents. The Florence Charter states, "No restoration or reconstruction should be allowed before thorough research is conducted in the original documentation of the ancient buildings and gardens and in the feasibility of the restoration is conducted. The preparation work shall be fully conducted and a thorough plan for restoration shall be submitted to a joint panel of experts and the authorities for approval before the restoration work gets under way" (ICOMOS-IFLA [1982] 1986). And the Washington Charter states, "Multidisciplinary research shall be conducted, which includes archaeology, history,

architecture, technology, sociology and economics, before a decision is made to restore a historical town or street" (ICOMOS 1986b).

Scientific methodology also influences the clear demarcation and precise definition of the managerial and technical means to conservation, for example, what can and what cannot be done to preserve a site. This is clearly stated in the 1964 International Charter for the Conservation and Restoration of Monuments and Sites (the Venice Charter), its addendum the Florence Charter of 1982, the Washington Charter on the Conservation of Historic Towns and Urban Areas (1987), and others (ICOMOS 1986a).

Emphasis on Daily Maintenance

Emphasis on daily maintenance is an essential and important task in the protection of cultural heritage.

Society and Heritage Protection

As a global task, conservation is aimed at "guaranteeing a fit living environment for the balanced and healthy development of all human beings where they can retain a relationship to nature and the traces of civilization that their forebears have handed down" (UNESCO 1986). Cultural property is the achievement and witness of different traditions and spirits of nations, the constituent of the national identity, and the foundation on which the nation's future is built. The ultimate purpose of preserving and exhibiting cultural and natural heritage is the future development of the whole of humanity: "The natural and cultural heritage should be made to play a positive role in contemporary social life, and so modern achievements, ancient values and the natural beauty of a historic site should be considered as a whole" (from International Heritage Conservation Law). Article 5 of the Venice Charter states that the use of heritage for the purpose of common interest is always beneficial to the relics themselves (ICOMOS 1986a). Accordingly, the protection of heritage, historic cities or towns, and the archaeological sites of a region should be taken into consideration when policy is being made regarding the general economic and social development of the district where the heritage is located.

A New Perspective on Conservation

Concepts discussed in the preceding sections have inspired Chinese scholars to consider conservation work from a fresh perspective. The conventions and agreements of international organizations and the charters and academic papers from

important conferences or well-known individuals have general applications. Implementation of these documents is considered most effective when national characteristics are taken into account in the practical work.

The Venice Charter (ICOMOS 1986a) states in its preface that it is absolutely necessary to establish internationally acknowledged principles in the effort to protect and to restore cultural heritage worldwide and that every country has the obligation to apply these principles in accordance with its own culture and tradition. The eighteenth conference of the World Heritage Committee also emphasized the need to consider the diversity of and differences among world cultures in the assessment of heritage values (Wang Qiheng, pers. com.). Therefore, as a charter-like document, the China Principles meet the need of the nation to preserve its cultural heritage while answering the call of international bodies and individuals for joint efforts.

Conservation Theory and Practice in China

Cultural heritage protection is in part a science. But is it an independent discipline? It is well known that the criteria for a scientific field to develop into an independent discipline are many: there must be absolutely clear objectives, independent basic theories, well-defined research subjects, and mature methodologies. As far as management is concerned, it must be absorbed into an established administrative system, a standardized division of subdisciplines, assessment standards, classical literature, and generally acknowledged achievements.

In this respect, China's cultural heritage protection is far from mature. It has not been considered an independent discipline. Academically, we have yet to develop complete and comprehensive fundamental theories. Luo Zhewen (2001) suggested at an international meeting that "a theoretical system and a practical system of cultural heritage protection with Eastern characteristics be established." We are presently well equipped for establishing the theoretical system: we have considerable experience and information; the objectives of the protection effort are adequately defined; the subjects of the research work have been confirmed by means of laws; and in methodology we have approached consensus as to the restoration of wood constructions and rock grottoes. The difficulty lies in establishing a fundamental theory and refining the methodology. Since conservation is an interdisciplinary field, techniques and methods must be borrowed from other subject areas. For instance, architec-

ture requires historical knowledge, and archaeology requires architectural, historical, environmental, artistic, legal, and economic knowledge.

Through the process of combining Chinese experience with the achievements in cultural heritage conservation from other countries, the China Principles, along with Commentary, synthesize concepts into a systematic approach that can be followed by practitioners. Thus the China Principles have significance in theoretical constructs for conservation in China.

Protection of China's immovable heritage cries out for a comprehensive conservation theory. A wide range of culturally important sites are found all over China, but different places seem to work on them according to their own understanding of conservation. In other words, no nationwide conservation standard yet exists in China. Policy makers and the people who implement the policies are not always conservation professionals, and the professional experts lack systematic guidance. All these circumstances pose great threats to the country's cultural heritage. Staff members of conservation institutions are not well trained, and they know little about the theories of cultural heritage protection. Those few universities with heritage conservation faculties do not have theoretical studies. These deficiencies demonstrate a lack of support for the conservation field from the public, and this hampers the establishment of a stable core of paraprofessionals and the sustainable development of a national effort to protect the country's cultural heritage. It is therefore urgent that China develop its own theoretical construct and approach to conservation.

Notes

- 1 Certain words in the China Principles, as commonly translated from the Chinese, are given below with their more usually accepted translations in parentheses:
 - Cultural relics (cultural heritage/property). For purposes of this paper, unless otherwise stated, the terms refer to immovable heritage, that is, sites.
 - Protection (conservation, preservation)
 - Restoration (repair)
- 2 This law was first adopted in 1982 at the 25th Meeting of the Standing Committee of the Fifth National People's Congress and last revised in 2002 at the 30th Meeting of the Standing Committee of the Ninth National People's Congress.

References

- Chen Mingda. [1953] 1998. [Several problems in the repair of ancient architecture.] In *Chen Mingda gu jian zhu yu diao su shi lun* = *Collected Works of Chen Mingda on the History of Ancient Architecture and Sculpture*, 16–23. Zhongguo gu jian shi lun cong shu, no. 1. Beijing: Wen wu chu ban she Xin hua shu dian jing xiao.
- . [1955] 1998. [What should be conserved and how to conserve?] In *Chen Mingda gu jian zhu yu diao su shi lun* = *Collected Works of Chen Mingda on the History of Ancient Architecture and Sculpture*, 69–73. Zhongguo gu jian shi lun cong shu, no. 1. Beijing: Wen wu chu ban she Xin hua shu dian jing xiao.
- Du Xianzhou. 1986. [How to conserve ancient architecture.] In *Zhongguo gu jian zhu xue shu jiang zuo wen ji*, ed. Shanxi sheng gu jian zhu bao hu yan jiu suo bian, 335–40. Beijing: Zhongguo zhan wang chu ban she: Beijing xin hua shu dian fa xing.
- Feilden, B. M. 1982. *Conservation of Historic Buildings*. Technical Studies in the Arts, Archaeology, and Architecture. London: Butterworth Scientific.
- ICOMOS. 1986a. The Venice Charter: International charter for the conservation and restoration of monuments and sites (1964): Article 9 [Chinese]. In *Guo ji bao hu wen hua yi chan fa lu wen jian xuan bian*, ed. China, Guo jia wen wu ju, Fa zhi chu (State Administration of Cultural Heritage [SACH]), 162–65. Beijing: Zi jin cheng chu ban she.
- . 1986b. The Washington Charter: Charter on the conservation of historic towns and urban areas (1987) [Chinese]. In *Guo ji bao hu wen hua yi chan fa lu wen jian xuan bian*, ed. China, Guo jia wen wu ju, Fa zhi chu (State Administration of Cultural Heritage [SACH]), 171–74. Beijing: Zi jin cheng chu ban she.
- ICOMOS and Second International Congress of Architects and Technicians of Historic Buildings. 1992. The Venice Charter: International charter for the conservation and restoration of monuments and sites (1964) [Chinese]. In *Bao hu wen wu jian zhu he li shi di duan di guo ji wen xian*, trans. Chen Zhihua, 113. Taipei Shi: Bo yuan chu bao you xian gong si.
- ICOMOS–International Federation of Library Associations and Institutions (IFLA) International Committee for Historic Gardens. [1982] 1986. The Florence Charter: Historic gardens (1982) [Chinese]. In *Guo ji bao hu wen hua yi chan fa lu wen jian xuan bian*, ed. China, Guo jia wen wu ju, Fa zhi chu (State Administration of Cultural Heritage [SACH]), 166–70. Beijing: Zi jin cheng chu ban she.
- Liang Sicheng. 1932. The pagoda of Kwanyin Sau, Chi Hsien. *Zhongguo ying zao xui she hui kan* = *Bulletin of the Society for Research in Chinese Architecture* 3 (2): 1–92.
- . 1935a. The architecture of the Temple of Confucius, Chu-fu, and plans for its restoration. *Zhongguo ying zao xui she hui kan* = *Bulletin of the Society for Research in Chinese Architecture* 6 (1).
- . 1935b. Plans for the restoration of the Liu-ho Pagoda, Hangchow. *Zhongguo ying zao xui she hui kan* = *Bulletin of the Society for Research in Chinese Architecture* 5 (3): 1–10.
- . [1964] 2001. [Thoughts on the rebuilding and maintenance of ancient architecture.] In *Liang Sicheng quan ji*, Di 1 ban ed., Sicheng Liang, vol. 5: 440–42. Beijing: Zhongguo jian zhu gong ye chu ban she.
- Liu Tuntseng and Liang Sicheng. 1934. Plans for the restoration of the Wanchun Pavilion, Coal Hill. *Zhongguo ying zao xui she hui kan* = *Bulletin of the Society for Research in Chinese Architecture* 5 (1): 81–92.
- Lu Zhou. 2001. [Liang Sicheng's ideas on conservation of ancient architecture.] In *Liang Sicheng xian sheng bai sui dan chen ji nian wen ji: 1901–2001*, ed. Qing hua da xue and Jian zhu xue yuan bian, 134–40. Beijing: Qing hua da xue chu ban she.
- Luo Zhewen. [1952] 1998. [The statute on conservation of ancient architecture.] In *Luo Zhewen gu jian zhu wen ji* = *Collected Works of Lui Zhewen on Ancient Architecture*, Di 1 ban ed., Luo Zhewen, 161–66. Zhongguo gu jian shi lun cong shu. Beijing: Wen wu chu ban she.
- . [1953] 1998. [The conservation, study, and propaganda of ancient architecture in the Soviet Union.] In *Luo Zhewen gu jian zhu wen ji* = *Collected Works of Lui Zhewen on Ancient Architecture*, Di 1 ban ed., Luo Zhewen, 167–79. Zhongguo gu jian shi lun cong shu. Beijing: Wen wu chu ban she.
- . [1955] 1998. [The conservation of monuments in the Soviet Union.] In *Luo Zhewen gu jian zhu wen ji* = *Collected Works of Lui Zhewen on Ancient Architecture*, Di 1 ban ed., Luo Zhewen, 180–88. Zhongguo gu jian shi lun cong shu. Beijing: Wen wu chu ban she.
- . [1986] 1998. [Indelibly remembering and deeply yearning.] In *Luo Zhewen gu jian zhu wen ji* = *Collected Works of Lui Zhewen on Ancient Architecture*, Di 1 ban ed., Luo Zhewen, 296–305. Zhongguo gu jian shi lun cong shu. Beijing: Wen wu chu ban she.
- . [1990] 1998. [Principles and application of novel materials and technology to the repair of ancient architecture.] In *Luo Zhewen gu jian zhu wen ji* = *Collected Works of Lui Zhewen on Ancient Architecture*, Di 1 ban ed., Luo Zhewen, 254–63. Zhongguo gu jian shi lun cong shu. Beijing: Wen wu chu ban she.
- . 1996. Advice in setting up a maintenance and conservation theory system for Chinese ancient architecture. *Zhongguo wen wu bao* = *Zhongguo wenwu bao* = *Chinese Cultural Relics News*, March 24, 3.
- . 2001. Advice in setting up a maintenance and conservation theory and scientific practice system for Eastern ancient architecture. Paper presented at the Asian Heritage Conservation Conference, Tokyo, March 6.
- Qi Yingtao. [1955] 1992. [First and second plan and comments on the project for recovery of the Cishi Pavilion of Longxing Temple,

- Zhengding.] In *Qi Yingtao gu jian lun wen ji*, 9–13. Beijing: Hua xia chu ban she: Xin hua shu dian jing shou.
- . [1978] 1992. [Maintaining and repairing ancient wooden architecture in China.] In *Qi Yingtao gu jian lun wen ji*, 28–105. Beijing: Hua xia chu ban she: Xin hua shu dian jing shou.
- . [1981] 1992. [Principles and practices for repairing ancient architecture in China.] In *Qi Yingtao gu jian lun wen ji*, 124–26. Beijing: Hua xia chu ban she: Xin hua shu dian jing shou.
- . [1984] 1992. [Primary exploration of several problems concerning repair of ancient gardens.] In *Qi Yingtao gu jian lun wen ji*, 164–68. Beijing: Hua xia chu ban she: Xin hua shu dian jing shou.
- . [1985] 1992. [Principles, procedures, and technology for repairing ancient architecture in China.] In *Qi Yingtao gu jian lun wen ji*, 169–233. Beijing: Hua xia chu ban she: Xin hua shu dian jing shou.
- . [1987] 1992. [Straightforward discussion on scientific evidence for projects of recovering ancient architecture.] In *Qi Yingtao gu jian lun wen ji*, 345–47. Beijing: Hua xia chu ban she: Xin hua shu dian jing shou.
- . [1988] 1992. [Summary of conservation of an ancient brick tower.] In *Qi Yingtao gu jian lun wen ji*, 353–59. Beijing: Hua xia chu ban she: Xin hua shu dian jing shou.
- Tsai Fangyin, Liu Tuntseng, and Liang Sicheng. 1932. Plan for the reconstruction of the floor, beams, and girders of Wenyuan Ke, Palace Museum, Peiping. *Zhongguo ying zao xui she hui kan = Bulletin of the Society for Research in Chinese Architecture* 3 (4): 78–87.
- UNESCO. [1968] 1986. Recommendation Concerning the Preservation of Cultural Property Endangered by Public or Private Works [Chinese]. In *Guo ji bao hu wen hua yi chan fa lü wen jian xuan bian*, ed. China, Guo jia wen wu ju, Fa zhi chu (State Administration of Cultural Heritage [SACH]), 51–61. Beijing: Zi jin cheng chu ban she.
- . 1986. Convention Concerning the Protection of the World Cultural and Natural Heritage. In *Guo ji bao hu wen hua yi chan fa lü wen jian xuan bian*, ed. China, Guo jia wen wu ju, Fa zhi chu (State Administration of Cultural Heritage [SACH]), 88–99. Beijing: Zi jin cheng chu ban she.
- Wang Ruizhu. 1993. *[Abroad, the History of Environmental Protection and Planning.]* Taipei: Shuxin chu ban she.
- Wang Yeqiu. [1957] 1997. [An open mind to learn from the advanced experience of the Soviet Union.] In *Wang Yeqiu wen bo wen ji*, Wang Jeqi and Guo jia wen wu ju bian, 49–54. Beijing: Wen wu chu ban she.

The Principles for the Conservation of Heritage Sites in China—A Critique

Jean-Louis Luxen

Abstract: *Publication by China ICOMOS of the Principles for the Conservation of Heritage Sites in China is an important event in the writing of heritage charters and guidelines. The document is innovative in that it comprises two complementary parts: the text setting forth the general principles and a detailed commentary explaining the principles. It is a comprehensive document overall, though evidently constrained somewhat in terms of its scope by China's legislative framework for heritage. The China Principles are in line with the principal international conventions and, in fact, are a response to the 1964 Charter of Venice. In terms of critique, the general principles skirt the issue of social value but cover them in the commentary, cultural routes are not covered, and historic urban and rural centers are not dealt with in sufficient depth. The China Principles have relevance for the entire country, with appropriate application to specific regional aspects of heritage sites, and are timely given the speed of change in China and the threats to cultural heritage. For a full understanding and expertise in applying the methodology, study and systematic training will be required if the China Principles are to realize their full potential.*

For some time now, voices have been raised to warn against the proliferation of charters, conventions, and other doctrinal texts addressing the conservation of cultural heritage. Admittedly, they all agree that discussions among conservation professionals have made it possible to draw up the major principles for the conservation of cultural heritage. However, the large number and unequal character of these charters undermine their credibility. In particular, they are criticized for having too broad a scope, thus giving rise to various, even divergent, interpretations.

The initiative to publish the *Principles for the Conservation of Heritage Sites in China* (Agnew and Demas 2004),

known simply as the China Principles, should nonetheless be acknowledged as a major event and as a demonstration of the interest generated by such doctrinal texts when they are well conceived. The China Principles are, in fact, a response to a recommendation of the 1964 Venice Charter, the founding act of modern conservation practices: “People are becoming more and more conscious of the unity of human values and regard ancient monuments as a common heritage. . . . Therefore, it is essential that the principles guiding the preservation and conservation of ancient buildings should be agreed and be laid down on an international basis, with each country being responsible for applying them within the framework of its own culture and traditions” (ICOMOS and Second International Congress 1964).

A Two-Part Document: Principles and Commentary

From a formal standpoint, the China Principles are innovative in that they consist of two distinct and complementary parts:

1. *Principles for the Conservation of Heritage Sites in China.* This text of global scope deals with concepts and general guidelines. It sets forth the general principles and presents the conservation process and the conservation guidelines, distinguishing between the different types of conservation interventions.
2. *Commentary on Principles for the Conservation of Heritage Sites in China.* This part is a detailed commentary that explains the China Principles explicitly and lists all the situations confronting professionals in their practice. It is an original

initiative that is extremely enlightening and useful. In methodical language, definitions are proposed, situations in the field are analyzed, and the various forms of intervention are described in a concrete manner.

Thus the China Principles constitute a comprehensive document. They serve as a basic reference and a kind of tool box that all conservation professionals should have within reach for regular consultation. However, given the document's length, it requires attentive study, and even systematic training, in order to acquire a full understanding of the directions it contains.

A Comprehensive and Carefully Elaborated Content

In terms of basic content, the China Principles provide a remarkable overview of current major practices in the conservation of cultural heritage at the international level, with a specific contribution that derives from the wealth and diversity of Chinese heritage and its long traditions of preservation and restoration. Fundamentally, the Principles are perfectly in line with the major guidelines of the Charter of Venice and the principal international conventions. China has played a leading role in their implementation, especially in the application of the World Heritage Convention of 1972 (UNESCO 1972): minimal and reversible interventions, an interdisciplinary approach, integrated conservation, the importance of regular maintenance, respect for authenticity, preservation of the setting, respect for the contributions of all periods to the monument, and a ban on additions or reconstruction based on conjecture. It should be pointed out that in many cases Chinese professionals and artisans responsible for managing palaces, temples, and tombs applied these norms before they were codified, thanks to the country's long tradition of preserving its heritage.

In terms of concepts, the China Principles incorporate the major preoccupations of the past few years:

- definition of authenticity in the spirit of the *Nara Document on Authenticity* (Lemaire and Stovel 1994);
- importance of the intangible dimension and the values of a cultural property;
- respect for decorative elements;
- opening up of cultural landscapes;
- special emphasis on the setting;
- recognition of commemorative sites; and
- taking into consideration tombs and cemeteries.

In terms of methods, the document also integrates the latest recommendations widely accepted by the international community:

- the decision-making process, as outlined in the Burra Charter (Australia ICOMOS 2000);
- participation of the inhabitants;
- recognition of heritage by ethnic groups and religions;
- importance of a master plan and a management plan, in compliance with the requirements laid down in the *Guidelines for the Implementation of the World Heritage Convention*;
- presentation and interpretation of heritage sites;
- risk preparedness;
- taking the economic factor into account, that is, heritage considered as a resource; and
- control of the number of tourist visits.

Analysis of the China Principles

Like all forwarding-looking documents of such complexity, the China Principles have areas that remain to be addressed.

Content

- The *social dimension of heritage* is not affirmed as such but only through its historic dimension, whereas the social factor could be accepted as a value in its own right, as in the case of many countries; an anthropological approach deserves to be advocated more strongly.
- The concept of *cultural routes* is neither defined nor analyzed despite the fact that China has some remarkable examples, starting with the different itineraries of the Silk Road.
- *Urban and rural ensembles* are mentioned, but not enough attention is drawn to this problem, even though China has experienced spectacular economic development that affects them directly and seriously. More efforts need to be made to recommend a linkage with UNESCO's 1976 *Recommendation Concerning the Safeguarding and Contemporary Role of Historic Areas* (UNESCO 1976). At the present time, historic urban centers

are under the responsibility of the Ministry of Construction, in ignorance of the China Principles.

- Although cultural landscapes are duly treated, it is surprising to note that *natural heritage* as such is not given specific attention in the China Principles, even though in many regions of the world, particularly in China, the fertile relationship between culture and nature deserves to be highlighted.

Approach and Implementation

- *Appropriation of the China Principles by the local players.* The approach to drawing up the China Principles seems to have been top-down: the process was initiated and conducted by the authorities responsible for heritage conservation, in consultation with international experts. This is reflected in its exhaustive and rational character. But the time has come for Chinese conservation professionals and local players to appropriate these principles, apply them to the concrete situations confronting them, and play a role as advocates vis-à-vis public and private decision makers. In this regard, it appears that the document was planned to collect illustrations of good practices to visualize the recommended measures. Such an exercise can be recommended wholeheartedly.
- *Diversity of Chinese heritage.* The China Principles are of general relevance for the entire country. From the point of view of implementation, in view of the size of the country and the diversity of its heritage (the outcome of the wide variety of climates, economic conditions, and cultural particularities), it will probably be necessary to accept certain adaptations of the Principles to specific regional features. Since plans have been made for participation by local populations, this adaptation will probably be set in motion automatically.
- *Firm support from public authorities.* Given the speed of the economic and social changes occurring in contemporary China, serious dangers threaten cultural heritage, especially the old centers and districts of towns and the traditional villages. To avoid the kind of damage that has been observed in so many countries, firm measures should be taken to protect the setting around cultural properties. More generally, an integrated conservation approach by the authorities responsible for town and regional planning is necessary to ensure the

protection and rehabilitation of urban and rural ensembles and to respect the identities and lifestyles of their inhabitants.

Conclusion

The China Principles clearly demonstrate the interest in adapting the imperatives of conserving cultural heritage to a country and its traditions. Not only do they provide an excellent overview of commonly acknowledged practices, but they enrich them with the long experience and approaches typical of China. In this respect, the China Principles contribute, in turn, to joint reflection. They are a fine illustration of the fertility of exchanges between different cultures and an invaluable contribution to mutual understanding.

A last observation: the China Principles are not restricted to Chinese heritage sites but cover “the heritage sites in China.” This is a good example of the sense of common responsibility to the heritage of different cultures.

References

- Agnew, N., and M. Demas, ed. 2004. *Principles for the Conservation of Heritage Sites in China = Zhongguo wen wu gu ji bao hu zhun ze [Chinese-language document] issued by China ICOMOS; approved by the State Administration of Cultural Heritage.* Los Angeles: Getty Conservation Institute.
- Australia ICOMOS. 2000. *The Burra Charter: Australia ICOMOS Charter for Places of Cultural Significance (1999): With Associated Guidelines and Code on the Ethics of Co-Existence.* Australia ICOMOS. www.icomos.org/australia/burra.html.
- International Council on Monuments and Sites (ICOMOS) and Second International Congress of Architects and Technicians of Historic Buildings. 1964. *The Venice Charter: International Charter for the Conservation and Restoration of Monuments and Sites.* Web page. www.international.icomos.org/e_venice.htm.
- Lemaire, R., and H. Stovel. 1994. *Nara Document on Authenticity.* Web page. www.international.icomos.org/naradoc_eng.htm.
- UNESCO. 1972. *Convention Concerning the Protection of the World Cultural and Natural Heritage.* Web page. <http://whc.unesco.org/archive/convention-en.pdf>.
- . 1976. *Recommendation Concerning the Safeguarding and Contemporary Role of Historic Areas.* Web page. http://portal.unesco.org/en/ev.php-URL_ID=13133&URL_DO=DO_TOPIC&URL_SECTION=201.html.

The Role of Hebei Province in Developing and Implementing the China Principles

Zhang Lizhu

Abstract: *This paper discusses the involvement of China's Hebei province in the development of the Principles for the Conservation of Heritage Sites in China, or China Principles (Agnew and Demas 2004), and their impact on the conservation of cultural heritage in the province. Experts from both the Hebei provincial and Chengde municipal cultural heritage bureaus participated in the working group that drafted the Principles. The bureaus are collaborating with the Getty Conservation Institute to establish a conservation and management master plan for the Chengde Summer Resort and its outlying temples as a component of the implementation strategy for the Principles.*

Hebei province has rich cultural heritage resources, and each type of cultural site has a particular significance. Conservation work started much earlier in this province than in other parts of China; therefore, the province has well-trained conservation personnel and well-organized conservation teams with extensive experience in conservation and management.

The provincial Cultural Heritage Bureau is putting the China Principles into practice by requiring that assessments and planning be conducted for every conservation project to improve quality. Supervision, guidance, and evaluation systems are integral to this approach and are put in place for the duration of projects. The bureau also has promoted the importance of conservation to the local government authorities and organizations and has attracted the involvement of local communities in conservation projects.

Hebei province, home to Beijing and Tianjin, is one of the cradles of Chinese civilization. Paleolithic people lived at the Nihewan site near the city of Yangyuan more than two

million years ago; the Nanzhuangtou site near Xushui and the Cishan site near Wuqan were home to ancient Chinese peoples from 7,000 to 10,000 years ago; ruins from the Shang dynasty (sixteenth–eleventh century B.C.E.) and the Zhou dynasty (eleventh century–221 B.C.E.) abound throughout the whole province; the Great Wall extends east-west across the province; and the royal gardens and tombs of the Qing dynasty (1644–1911 C.E.) are among the highlights of the cultural heritage sites in this region.

So far 12,215 sites of immovable cultural heritage have been discovered in Hebei, including 88 national-level protected sites, 670 provincial-level protected sites, and 3,476 county-level protected sites. More than 900,000 archaeological objects have been unearthed from these sites. Five towns have been designated historical and cultural heritage at the national level, three at the provincial level. The Great Wall, the Chengde Summer Resort and its outlying temples, and the Eastern and Western Qing dynasty tombs are on the World Heritage List.

As the above description demonstrates, Hebei province is rich in historical sites and artifacts that represent the continuous development of Chinese culture. Our heritage conservation work in the province started very early and enjoys the best expertise the country has to offer. Hebei personnel account for 10 percent of the heritage conservation staff in China. Over decades of conservation work, we have accumulated ample experience in the technology and management of heritage conservation. Because of this, Hebei province has played a key role in drafting and testing the *Principles for the Conservation of Heritage Sites in China* (Agnew and

Demas 2004), known simply as the China Principles. These standards for conservation play an even greater role in Hebei province than in other parts of China.

Drafting the China Principles

In 1997 China's State Administration of Cultural Heritage (SACH) and the Getty Conservation Institute (GCI), along with the Australian Heritage Commission, initiated the drafting of the China Principles. The Hebei provincial Cultural Heritage Bureau and the Cultural Heritage Bureau of Chengde City assisted in the process.

In 1998 and again in 2000, this author, together with staff members of the Chengde Bureau, undertook research on cultural heritage conservation in Australia and the United States. In Australia, we investigated the application of the Burra Charter of Australia ICOMOS and studied its relevance to the drafting of the China Principles; in the United States, a wide range of heritage sites, from historic cities to archaeological sites, were visited as part of the study tour.

In June 2001 the China Principles were finalized in Chengde; thus this document could also be known as the "Chengde Charter." The document was formally issued by China ICOMOS with the authorization of SACH. It is the product of the experience of Chinese heritage experts and the knowledge of Western scholars in the field and the continuation and development of the Burra Charter. With its Chinese perspective, the China Principles have universal value in the guidance of China's cultural heritage conservation work.

Implementing the China Principles in Hebei Province

The China Principles were first applied to conserve and manage parts of two World Heritage Sites in Hebei province: the Shuxiang Temple at the Chengde Summer Resort and cave 85 at the Mogao Grottoes. The project at Chengde (planning and architectural conservation) was conducted jointly by the Hebei provincial Cultural Heritage Bureau, the Cultural Heritage Bureau of Chengde City, and the GCI.

Significance of the China Principles

The China Principles clarify the scope and content of a conservation project. The document is highly practical, and it standardizes format and approach. It provides guidelines and solutions to many of the long-unsettled controversies

concerning conservation approaches. Consequently, conservation projects will be implemented more scientifically and systematically, fully guaranteeing the authenticity of the historic nature of the heritage. The standards embodied in the China Principles and which guide the conservation of cultural heritage in China can be summarized as follows:

1. *Cultural heritage conservation and the management process are of vital importance and are expressly formulated in the China Principles.* Since historic cultural relics vary with regard to place and age, it is impossible, even impractical and unscientific, to attempt a treatment methodology that applies to them all. On the other hand, since the historic sites and artifacts are fragile and cannot be re-created, the conservation work cannot afford the risks of arbitrary interference or treatment.
2. *All interventions applied to heritage sites, as well as their management, should be guided by the following procedure: investigation, assessment, planning, and implementation.* If this procedure is followed with accuracy, minor methodological defects of any kind will not lead the work astray. Any unreasonable simplification or abridgement of the procedure will, however, damage the relics and the message they carry.
3. *Clarification of the responsibilities and rights of the conservation managers is key to the effective accomplishment of the conservation project.* The China Principles make it clear that those institutions with direct operational responsibility at the lowest administrative level are the day-to-day managers of cultural sites and the executors of the basic tasks; they serve as supervisors for the entire process of heritage conservation work. The China Principles also clarify which category of work is to be undertaken by the site authority and which by public organizations or other agencies. The site authority should be the decision maker, organizer, supervisor of conservation and research, and work monitor, and it should also receive credit when the site is well managed and successful projects are undertaken.
4. *Dissemination of the China Principles promotes and improves the expertise of the work staff and the quality of their achievements.* This issue is discussed in detail in the next section.

Dissemination and Application of the China Principles in Hebei Province

The China Principles have been disseminated to management personnel at heritage conservation institutions in Hebei province, and they serve as the basis for establishing policies concerning conservation projects. The China Principles have also influenced the drafting of other significant guidelines that regulate conservation work in Hebei province, such as *Regulations for Cultural Heritage Conservation Management in Hebei Province* and *Regulations for the Security and Safety of Cultural Heritage during Conservation Intervention Projects in Hebei Province*. They also played a vital role in establishing state certification in planning, estimation, and construction personnel for the leading reconnaissance design and construction team. The state certificate clarifies the legal responsibilities of the project managers, stresses operational procedures, and tightens the contractual management of projects and the legal authorizations required prior to commencement of work.

The Hebei provincial Cultural Heritage Bureau is actively promoting the China Principles to all levels of local government, as well as to the public, to mobilize their support. Although cultural heritage conservation is mainly the duty of the government, public participation contributes to the best results. Only if both the government and the public understand and accept the importance of conservation work can the desired outcomes be accomplished.

The China Principles in Action

Among the first entities to adopt the China Principles was the Ancient Architecture Conservation Institute of Hebei province. The institute began applying the Principles to its work, even when they were still being drafted, by refining working procedures and evaluation criteria. In subsequent planning and design tasks, both inside and outside the province, the institute made an effort to conform its work to the specifications formulated in the China Principles, which won a high evaluation from the sponsoring institutions and the national cultural heritage authority.

The institute's adherence to the China Principles is evident in its work at the Daxiong Hall, which dates to the Liao dynasty (916–1125 C.E.). It is located in the Kaishan Monastery at Xincheng City, Hebei province. The institute undertook a large amount of research as part of the restoration process for Daxiong Hall. Each physical intervention

was preceded by substantial investigation and debate, every stage of the procedure was documented in detail, and all historical information that the building carries was preserved as accurately and as completely as possible.

The China Principles have also been disseminated to all World Heritage Sites in China and to all heritage conservation institutions in Hebei province, requiring them to undertake assessment and planning before a conservation measure is carried out. For example, projects for the ancient fortress at the Shanhaiguan Pass, built in 1381, started with a full-scale assessment, and then a detailed plan was drawn up. The planning addressed both the cultural relics inside the fortress and the fortress itself. A tourist development program was also drawn up to balance protection and use. Likewise, the conservation of Dingzhou City, a provincial-level historic site, and Jimingyi in Huailai, the best-preserved ancient post station in China, was conducted in the same manner.

The Hebei provincial Cultural Heritage Bureau is now conducting a series of assessments of the value, significance, and state of preservation of all historic sites at the provincial and national levels. The result of these assessments will be used to draft general project plans for cultural heritage conservation for the entire province. The major heritage protection institutions in Hebei province have been asked to draft their own plans for conservation and management so as to standardize their work procedures. So far, master plans for the Eastern and Western Qing dynasty tombs and the Chengde Summer Resort have been completed and approved by the People's Congress of Hebei Province. They will be disseminated and enforced as legal regulations.

The Importance of Experts

In the course of implementing the China Principles, the Hebei provincial Cultural Heritage Bureau became aware of the importance of the role of experts in supervising and guiding conservation work. A standing committee of experts in heritage conservation was established that includes specialists in ancient building restoration, archaeologists, and architects. The experts were consulted at the beginning of the Shanhaiguan Pass ancient fortress project for project assessment, fieldwork guidance, quality control, and other policy-related activities. With their valuable assistance, the conservation and development of the ancient fortress of Shanhaiguan Pass were accomplished successfully.

The Public's Role in Conservation

The China Principles call for wide-ranging input on conservation projects, from professionals and from the general public. This input has helped to clarify many issues that have puzzled us for decades, for example, how the value of heritage sites should be assessed, how to balance preservation of their current condition with restoration of their original form, and how to balance cultural values with the commercial benefits that derive from use of sites.

At the Hebei provincial Cultural Heritage Bureau, the entire bureau staff, from director to employee, have studied the Principles and understand the spirit of the document, and they have reached out to people throughout Chinese society to promote understanding and awareness of cultural heritage. For example, the iron lion in Cangzhou, cast in 963 C.E. and measuring 5.4 meters high by 6.3 meters long, was in lamentable condition because of an earlier treatment failure. To save this treasure, the provincial government advertised in the mass media seeking proposals for remedial measures from the public. This met with an enthusiastic response. Experts were invited to explain the value of the iron lion to all interested people and institutions, to analyze the strengths and weaknesses of the submitted proposals, and to offer specific suggestions. Through this process, all participants came to a

full understanding of the significance of protecting the iron lion and the bureau learned from the public.

Conclusion

We are honored that the *Principles for the Conservation of Heritage Sites in China*—the China Principles—were created in Hebei province and that we are among the first to have implemented the guidelines. As a province rich in cultural heritage, Hebei has benefited greatly from international cooperation in the field of cultural heritage conservation. We have formed theories about conservation that are universally practical and meet the specific needs of China. We will refine and develop these theories through our practice. The application of the China Principles will elevate heritage conservation work in China to higher and higher levels.

References

- Agnew, N., and M. Demas, eds. 2004. *Principles for the Conservation of Heritage Sites in China = Zhongguo wen wu gu ji bao hu zhun ze* [Chinese-language document] issued by China ICOMOS; approved by the State Administration of Cultural Heritage. Los Angeles: Getty Conservation Institute.

PART THREE

History and Silk Road Studies

A Place of Safekeeping?

The Vicissitudes of the Bezeklik Murals

Susan Whitfield

Abstract: *Destruction of the Bamian Buddhist statues reminded us all too starkly of the fragility of our cultural heritage. This was not the first time objects have been destroyed in situ, nor will it be the last: wars, vandalism, and natural disasters will continue to take their toll. It is vanity to assume we can always predict or prevent such losses. In the early twentieth century, the actions of German archaeologists, who were among the first to remove many of the first-millennium murals from Buddhist sites around Turpan (or Turfan) and Kucha in today's Xinjiang Uyghur Autonomous Region of China, were decried as vandalism. Only two decades later, war in Europe destroyed many of the finest pieces. There is no place of safekeeping.*

The Buddhist cave site at Bezeklik near Turpan provides an excellent case study to illustrate the complex issues involved in the preservation and conservation of cultural relics and the primary importance of documentation. Many of the Bezeklik murals transported to Berlin and later destroyed by bombing were published as high-quality prints, invaluable to scholars today. This paper argues for the importance of detailed documentation, which should precede or at least accompany conservation efforts. It shows how the meticulous documentation carried out by some of the much-criticized archaeologists of the early twentieth century is now being used to identify and bring together dispersed collections and to reconstruct lost finds. All public cultural institutions have limited budgets, and providing cultural artifacts with a stable environment that ensures that they deteriorate as little as possible is of the highest priority for these funds. Documentation, however, should have equal priority.

Destruction of the Bamian Buddhist statues reminded us all too starkly of the fragility and impermanence of our cultural heritage. This was not the first time objects have been destroyed in situ, nor will it be the last: wars, vandalism, and natural disasters will continue to take their toll. It is vain to assume we can always predict or prevent such losses. In the early twentieth century, the actions of the German archaeologists who were among the first to remove many of the first-millennium murals from Buddhist sites around Turpan (or Turfan) and Kucha in the present-day Xinjiang Uyghur Autonomous Region of China were decried as vandalism. For the most part, however, the murals survived the transfer to what the archaeologists genuinely believed was a safe place where they would be accessible for future generations of scholars. Only two decades later, war in Europe destroyed many of the finest pieces. There is no place of safekeeping.

The Buddhist cave site at Bezeklik near Turpan provides an excellent case study to illustrate the complex issues involved in the preservation and conservation of cultural relics and the primary importance of documentation. Bezeklik is located in a canyon northeast of the ancient ruined city of Karakhoja (also known as Gaochang and Khocho) and 50 kilometers east of present-day Turpan (fig. 1). In the fifth century a series of temple caves were excavated 25 meters up the cliff face from a deep ledge looking down onto the river that flowed from the Tianshan to the north. Work continued for several centuries, and mud-brick freestanding temple buildings with domed roofs were also constructed on the ledge, where space permitted, with their backs hard against the cliff and, in some cases, opening into a cave. The caves and freestanding temples extended about 300 meters along the cliff (fig. 2). The largest of these structures is over

FIGURE 1 The Bezeklik cave complex today. Photo by Colin Chinnery. Courtesy The British Museum, Photo 1118/1 (25)

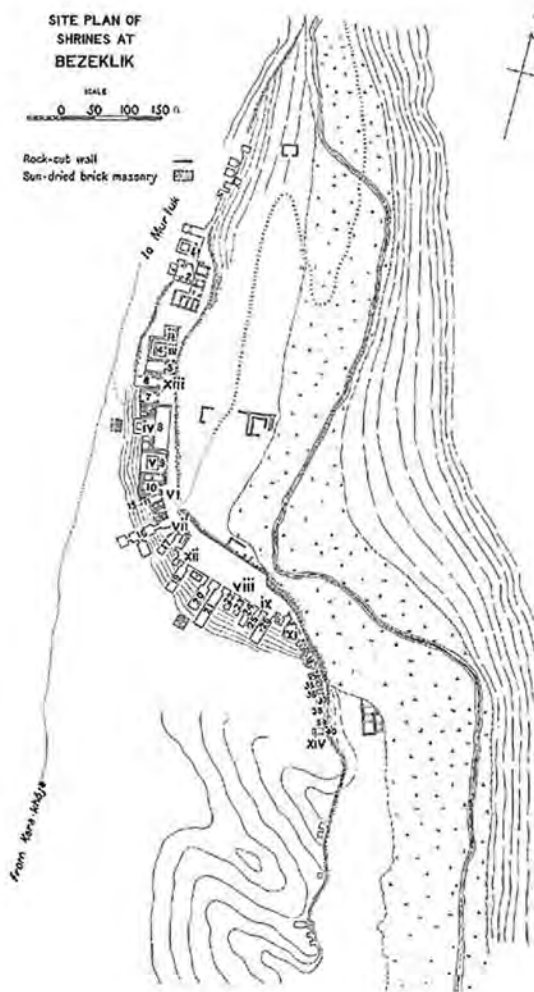

FIGURE 2 Site plan of the shrines at Bezeklik.

18 meters deep; the smallest, only 1.55 by 1.72 meters. They were decorated with murals and statues, like the cave temples at Dunhuang using many of the same techniques, and activity probably continued until the fourteenth century. Most murals showed Buddhist subjects, and many depict their Uyghur donors, but there are also some rare Manichaean murals (Jia Yingyi 1990). Many of the murals depicted *pranidhi* scenes, a name given to paintings common in Uyghur Buddhism that refers to the vow, or *pranidhidana*, to attain enlightenment, specifically, paintings of buddhas of past ages predicting Sakyamuni's enlightenment (Leidy 2001: 211–19).

Unlike Dunhuang, which still attracted pilgrims into the twentieth century, Bezeklik seems to have fallen into complete disuse by the late nineteenth century. It was placed under state protection by the State Council of the People's Republic of China in 1982.

Removal of Artifacts from Turpan Sites

In the late nineteenth and early twentieth century a series of explorers and archaeologists vied with each other to be the first to uncover and excavate the ancient sites of the eastern Silk Road on the fringes of the Takla Makan and Gobi Deserts. Most of the sites were deserted, and many had been partially covered by the desert sands. The archaeologists acquired numerous manuscripts and archaeological artifacts from these sites, most of which dated from the first millennium C.E. Some also removed murals and statues from the temples. All these objects were carefully packed into wooden crates and sent to Europe, Japan, the United States, and India.

The majority went first by camel and yak to the Russian-constructed railways into central Asia and the steppes and then by rail to Europe. Others were transported by pack animals across the mountains into India, and some continued by ship from there to various countries throughout the world. Almost all were placed in public museums on their arrival.

The region around Turpan was especially rich in such sites, as it had been an important staging post on the northern branch of the Silk Road. It was also reasonably accessible, especially from the Russian steppes to the north. The first European visitor in the modern era was Ioann-Albert Regel, a Russo-German botanist who was director of the Imperial Botanical Garden in St. Petersburg. He visited Turpan on his second expedition to central Asia in 1879. He noted the existence of an ancient ruined city, probably Karakhoja, but it was not until the end of the century that this and other sites in the area started to be surveyed and excavated. For fifteen years the Turpan area was the main focus of German expeditions, but it also received the attention of Russian, British, and Japanese archaeologists.

Early Exploration of Bezeklik

Other European explorers of eastern central Asia visited Turpan after Regel, among them the British Andrew Dalgleish (in 1885–86) and Francis Younghusband (in 1886) and the Russian Grum-Grijimailo brothers (in 1888). The first to concentrate on Turpan's archaeological sites, however, was Dmitri Klementz, in 1898. Klementz was sent by the Eastern-Siberian branch of the Russian Imperial Geographical Society. He surveyed the Bezeklik temples and noted that many were impossible to enter, being filled with sand that had either blown in through the cave openings or fallen in through the broken domed roofs of the freestanding buildings. In the ones he could enter he noted that no statues survived. He found only traces of their bases or where they had been attached to the walls to suggest their original existence. From the marks on these remains, he surmised that they had been hacked away. He also reported the defacement of the murals. Some of the faces had been gouged out, and others had been smeared over with mud. His written report notes that he acquired forty fragments of paintings and fifty-nine inscriptions (Klementz and Radlov 1899).

On Klementz's return to Europe, he visited the Museum of Ethnology (Museum für Völkerkunde) in Berlin and spoke of the sites of Turpan to Albert Grünwedel, head of the museum's Indian Department. Grünwedel made the following report on Bezeklik:

Klementz and his self-sacrificing spouse found a whole series of cave temples from the Buddhist era, the entrances to which had been blocked up by sand drifts, but which were accessible via small openings made by the present inhabitants. All these cave temples are full of wall paintings (frescoes), the preservation of which is now greatly endangered by the fact that the Muhammadan population of the neighbouring villages has got into the habit of breaking off pieces thereof to fertilize their fields. Thanks to the foresight of the Imperial Academy, about 50 lb of such detached fragments of murals have already been brought to Petersburg, and a painter has been sent to make copies on the spot. I have seen a dozen or so such pictures, which were shown to me by the aforementioned gentlemen on their way to the Congress of Orientalists in Rome. (Cited in Härtel and Yaldiz 1982: 26–27)

Grünwedel's report suggests that the mural fragments were acquired by Klementz from locals. The theme of the "recycling" by locals of the soil used for the base of murals and from other ancient structures, either for fertilizer or as building materials, is widely reported, and not only by those eager to find a justification for their own removal of murals and structures. For example, the redoubtable and observant British missionaries Mildred Cable and Francesca French bemoaned the condition of Karakhoja, the ancient city south of Bezeklik, when they visited some decades later:

Destruction of the buildings had been going on for a long time, and we saw farmers at work with their pickaxes pulling down the old ruins and probably destroying many relics in the process. The agriculturists of the district found the old earth valuable for enriching their fields so they ploughed up the land . . . and sowed crops around the old monuments, but unfortunately the irrigation . . . is fatal to structures made of earth. . . . The peasants' ploughshares constantly brought treasures to light, and we came away with a seal, an old metal horse, a fragment of a Uighur manuscript, and other small relics. Many beads are collected by the children as they play among the ruins, and any old pots which are unearthed are taken into immediate use by the women, to save the expense of buying others. (Cable and French 1950: 201)

The German Turpan Expeditions

Klementz's report was instrumental in persuading Grünwedel to make Turpan the target of his 1902 expedition, made possible by a combination of museum and private funding. His party included a scholar, Georg Huth, and a museum technician, Theodor Bartus. Bartus would go on all subsequent German expeditions. He acted as photographer and was also responsible for the actual removal of many of the murals. The party reached the Turpan oasis in December and remained until March 1903, visiting the ancient city ruins of Karakhoja, the Bezeklik temples, and other nearby Buddhist cave sites at Sengim and Toyuk. They returned along the northern Silk Road to Kashgar, stopping at other sites en route. In total, they acquired forty-six cases of archaeological finds, but these did not include any from Bezeklik. The finds were sent overland to Berlin.

Because of the success of the first expedition, the Prussian state funded three additional expeditions. The first of these, in the absence of Grünwedel, owing to illness, was led by Albert von Le Coq, who set out in November 1904. The expedition went again to Turpan, and in March 1905, after several months' work at Karakhoja, von Le Coq moved his attention to Bezeklik. He reported that several of the southern caves were occupied by goatherds, and the murals were covered by the soot from their fires. The party camped in other caves in the southern section and spent the next few months clearing the northern caves of sand and sawing out the best examples of extant wall paintings. They concentrated especially on the almost intact *pranidhi* scenes from one freestanding temple, later numbered Temple 9 by Grünwedel. The finds from this second expedition numbered 103 crates, mainly holding Bezeklik murals.

On his recovery, Grünwedel set out for central Asia, and von Le Coq left Turpan to meet him in Kashgar in December 1905. Because Grünwedel again took leadership, this is seen as the start of the third German Turpan expedition, and both men and their party traveled east again to resume work. They first excavated at sites en route before Grünwedel reached Turpan in July 1906 (by this time illness had forced von Le Coq to return to Europe). Grünwedel made further removals of wall paintings in late 1906 and drew detailed plans of the forty largely extant caves, giving them his own numbering system. The photographs taken by Bartus clearly show the scouring effect of the sand on the murals. They also show defacement of many of those in situ and thus support Klementz's original report on their condi-

tion (Grünwedel and Preussische Turfan-Expeditionen 1912: figs. 535, 532). The 118 crates of finds from this expedition also included Bezeklik murals. The fourth expedition (1913–14) did not visit Turpan.

Mannerheim and Stein

The next European visitor to the site was Baron Carol Gustav Mannerheim, later Marshal Mannerheim, president of Finland (1944–46). At this earlier time Finland was an autonomous protectorate of Russia, and Mannerheim was a career soldier in Tsarist Russia's imperial army. Having been promoted to colonel during the Russo-Japanese War (1904–5), he was sent in 1906–8 on a reconnaissance expedition to northern China sponsored by the Russian military. Archaeology was not his primary concern, and on arriving at Bezeklik in October 1907, he simply observed that "the very badly damaged wall paintings (entirely broken off for large expanses) still gave an idea of what there was in days gone by" (Mannerheim and Hildén 1969: 1, 360). Of course, the missing murals included those taken by the locals, Klementz, and the Germans.

M. Aurel Stein, the Hungarian-born British archaeologist-scholar, was also on the Silk Road at this time, on the second of his four expeditions to the region. His focus, in contrast to Mannerheim's, was scholarship and archaeology, but in his first two expeditions he concentrated his activity on the ancient ruined cities and temples to the south of the Takla Makan. Although he visited Turpan in 1907 and arrived at Bezeklik in November directly after Mannerheim, he did not carry out excavations or take photographs at this time. Stein again concentrated on the southern sites on his third expedition in 1913 but then moved to Turpan in December 1914. He recorded his impressions of Bezeklik:

This visit had shown me that those shrines still retained a great portion of their wall paintings. But it had also afforded unmistakable evidence of the increased damage which the pictorial remains of this, the largest of the Buddhist sites of Turfan, had suffered from vandal hands since my first visit in November 1907. . . . With the sad proofs of progressive damage before my eyes, I could feel no doubt that, as local protection was out of the question, careful removal of as much of these mural paintings as circumstances would permit and artistic or iconographical interest would warrant, offered the only means of assuring their security. (1928: 634).



FIGURE 3 Bezeklik mural from the west wall of Temple 4, which was removed during Aurel Stein's expedition in early 1915 and is now in the National Museum, New Delhi. From Andrews 1948: pl. 16

Stein took a series of large-format photographs inside several of the caves, including Temples 4 and 9 (using Grünwedel's numbering),¹ and these clearly show their deteriorating condition. For example, Photo 392/29(193) shows the east wall of Temple 9 with the lower half missing and the two bodhisattvas both defaced. Photos 293/29(197) and (199) show the west wall of Temple 4 with a buddha and bodhisattvas, all defaced (Andrews 1948: pls. 15, 16). Stein later removed this mural from Temple 4 (fig. 3).

Japanese Expeditions

By the time of Stein's second visit to Bezeklik, members of Japanese expeditions, sponsored by Count Otani, abbot of Nishi Honganji Monastery in Kyoto, had also visited. The first Otani expedition was in 1902–4, before the second German visit. The young monk-explorers visited Bezeklik in 1903 and probably removed some murals. They also took photographs.

The second Otani expedition (1908–9) also acquired material from Bezeklik, including one large *pranidhi* painting, which does not have noticeable defacement, and smaller fragments from Temple 4, many of which had already been defaced. The large panel, which does not show noticeable defacement, was in the rear of the cave, and one might surmise it had been protected by the sand that originally filled these caves, as reported by Klementz and von Le Coq.

Russian Expeditions

The scholar Sergei Oldenburg, later the first director of the Institute of Oriental Studies in St. Petersburg, led two Russian expeditions to central Asia, in 1909–10 and 1914–15, later called the Russian Turkestan expeditions. His team included the artist and photographer Samuel Dudin. They visited the Turpan area on their first expedition and removed mural fragments from Bezeklik, including a complete *pranidhi* scene from Temple 4. There is no record of any visit to the site on the second expedition.

Dating the Defacement of the Bezeklik Murals

Klementz's report of the generally undefaced state of the paintings removed from Temples 4 and 9 (fig. 4) and modern photographs of the murals (Jia Yingyi 1990) suggest that there was already considerable damage to exposed paintings by 1898. However, those covered by sand were protected and remained in a good condition. Stein's comments suggest that they had been defaced once the sand was removed and before the site came under state protection. The documentation available to us, however, is not sufficient to be sure of the date or perpetrators of the defacement.

Dispersal of the Bezeklik Murals and Supporting Documentation

Although Bezeklik received other foreign visitors after Stein, as far as I have been able to ascertain, Stein was the last to remove murals from the site. By this time those murals previously removed by the various archaeologists mentioned above had been dispersed to various collections worldwide. This section explores the destination and fate of these collections, considering documentation, conservation, exhibition, publication, and access. This information, however, is not always readily available, especially on early conservation attempts and on current access.



FIGURE 4 Bezeklik mural from Temple 9, which was removed by von Le Coq and later destroyed during World War II bombing. From von le Coq 1913

Russian Expeditions

Klementz's and Oldenburg's finds, expedition notes, and photographs were sent directly through Xinjiang by pack animal, then by railway to institutions in St. Petersburg. Both men published expedition reports with sections on Bezeklik (Klementz n.d.; Ol'denburg 1914). These are in German and Russian respectively and have not been translated. Klementz's papers and archives were later transferred to what is now the Institute of Oriental Studies, St. Petersburg branch of the Russian Academy of Sciences; Oldenburg's are in the archives of the St. Petersburg branch of the Academy of Sciences itself (he became an academician). Their nonmanuscript finds (artifacts, murals, textiles, etc.) and photographs are now in the State Hermitage Museum. I have been unable to confirm that the Hermitage has all of the wall paintings and inscriptions listed by Klementz, and it is possible that these are still in the *Kunstkamera* Museum of Anthropology

and Ethnology or another institution in St. Petersburg. One piece is on display in the Hermitage. The whereabouts of the copies of the murals made by the painter sent from St. Petersburg and reported by Grünwedel is not clear.

Many of the Hermitage's collections were evacuated from the city by train during the German blockade in World War II. There was not time, however, to remove them all, and some, although protected by staff who remained in the city during the blockade, were damaged. These included the *pranidhi* scene removed from Temple 4 by Oldenburg. In 1953–54 it was partially restored by Hermitage conservators, but the gypsum slabs to which it had previously been attached were left in place and the plaster layer continued to deteriorate. In 1999 the Hermitage initiated a conservation program for the Turpan material (Blyaher, Vasilenko, and Gagen 2002), and in May 2002 the Temple 4 *pranidhi* scene went on display.²

German Finds

Grünwedel and von Le Coq's finds were also sent overland to Europe and, following conservation, were put on permanent display at the Museum of Ethnology in Berlin in 1926. The larger pieces were fixed to the gallery walls (fig. 5). By 1928 there were twenty-seven large rooms devoted to this material; in addition, the expedition notes, photographs, drawings, and plans were placed in the museum's archives. Both men published detailed expedition reports within a few years of their return (Grünwedel and Preussische Turfan-Expeditionen 1912; Le Coq 1913). Grünwedel's report reproduced his detailed site plans and a description of each temple, along with a selection of photographs. Von Le Coq's contained a very detailed description of Temple 9, including large-format and very high quality color and black-and-white lithographs of the many *pranidhi* scenes.

In 1934, with the threat of war, the museum curators started to compile lists categorizing the collections, and in 1938 many artifacts were moved into cellars and air raid shelters in Berlin. In 1944 the collections were moved once more, this time to salt mines throughout Germany. The material included many of the Bezeklik murals. Because the large murals fixed to the gallery walls could not easily be removed, they were protected in situ with sandbags and prayers. These were ineffective as the museum, in the center of the city, was bombed, and the paintings were destroyed. Only fragments were retrieved (Yaldiz 2000).

After the war the collections that had been dispersed for safekeeping were recalled to the museum, and in 1963



FIGURE 5 Bezeklik murals in Berlin's Museum of Ethnology before the building was bombed during World War II. Courtesy of the Museum für Indische Kunst, *Dokumentation der Verluste*, Band III, Berlin, 2002, 11.

they were transferred to the Museum für Indische Kunst in Berlin-Dahlem southwest of the city. A new building was inaugurated in 1971, and the galleries were refurbished in 1998. Some of the Bezeklik material was shown in a 1982 exhibition in New York (Härtel and Yaldiz 1982). However, more than two thousand accession numbers of the dispersed collections were unaccounted for, and some of this material was later discovered to have been taken by the Soviets on their withdrawal from Germany. Documentation has recently helped in the identification of some of this missing material (see below). Some other material from Germany was dispersed elsewhere, including a banner fragment from Bezeklik that von Le Coq had sold and which is now in the Yale University Art Gallery (Zhang Guangda and Rong Xinjiang 1998: 28).

Japanese Collections

The Japanese collections were sent to Kyoto but were dispersed soon after Otani resigned as abbot of Nishi Honganji Monastery in 1914. Unlike the other expeditions, the Japanese monk-explorers were privately funded by Otani, so the finds were not deposited in public collections. However, by 1926 the first expedition material was in the Imperial Gift Museum of Kyoto, but by 1944 these items were again in private owner-

ship, in the collection of Teizo Kimura. The Japanese government had to purchase them back after the war. Along with other items bought from other individuals, the collection was deposited in the Oriental Section of Tokyo National Museum, where it remains today. This includes some of the Bezeklik paintings.

A large part of Otani's second and third expedition material was kept in his house and sold along with the house in 1916. The buyer, Fusanoske Kuhara, presented the collection to his friend Masatake Terauchi, governor-general of Korea (annexed by Japan in 1910). Terauchi kept the collection in the Museum of the Governor-General, which later became the National Central Museum in Seoul. It remains there today and also includes a number of the Bezeklik paintings.

Some of Otani's papers, which included documentation from his expeditions, and his expedition photographs were given to Ryukoku University in Kyoto and are kept in the university's library. The photographs and papers have been cataloged and are available to the public via the library catalog.³ Some of these have been displayed at various exhibitions.

Stein Expeditions

The murals acquired by Stein on his second visit to Bezeklik were sent directly to Lahore, then part of British India, where they were acquisitioned by Fred Andrews, who was working as an assistant to Stein. Stein directed the design of display cases to house them in three large galleries in the building of the Archaeological Survey of India. These galleries were called the Central-Asian Antiquities Museum. By 1937 the murals had been conserved, and they were displayed until 1991. However, by this time they were reportedly suffering from "flaking and bulging" from the dampness in the building, which was subsequently demolished (Singh 1996: 57). The murals were then moved to the National Museum, New Delhi, which had been built in 1961 and already housed the part of the Stein collections that had been sent to India (the remainder were in the British Museum in London). However, the murals were kept in storage in galleries originally designed to display them. Since then the museum has carried out further conservation work, but as of 2006, they were still not on public display.

Stein published a detailed report of his third expedition in 1928. His photographs and papers were later deposited in various institutions: the largest part of the former are now in the British Library in London and of the latter in the Bodleian Library, Oxford University. The Library of

the Hungarian Academy of Sciences also has substantial collections (Falconer et al. 2002). A portfolio of large-scale reproductions of many of the paintings from Bezeklik was published in a 1948 catalogue, including both black-and-white collotypes and color lithographs (Andrews 1948).

Documentation of Archaeological Finds

Given the complex circumstances of the removal and dispersal of the Bezeklik murals over the past century, it would be easy to imagine difficulties tracking not only the current whereabouts of all the material but also the exact find site of each fragment. The original documentation of the archaeologists is the main aid to this latter task, but this varies greatly between archaeologists and between expeditions. For example, members of the first German expedition carefully wrapped each item and marked the wrapper with a signature—or string of characters—indicating its provenance. On accession in the museum the signature was transferred to the items and the original wrappers discarded. Grünwedel and von Le Coq distinguished between those items excavated at a site and those purchased from local people, for which provenance is, of course, less certain. Artifacts from Bezeklik were marked with the site signature “M,” standing for Murtuk, a nearby village.

Assigning a signature to each item after a long day of excavation in the field required an outlay of time and energy. It is not surprising, therefore, that this practice apparently was not continued consistently throughout the second and third German expeditions. What is surprising is that Stein implemented a similar system and kept it up throughout all his expeditions, resulting in over fifty thousand items from over one hundred sites being individually provenanced. Not only was Stein’s method more thorough than that of Grünwedel and von Le Coq; it was also safer. He wrote the signature on the item itself and kept a full list of the documented items that he then published in his expedition reports.

The following is an example of Stein’s coding system used for another Silk Road site. The wooden document shown in figure 6 bears Stein’s ink signature “N.XXIV.viii.19.” “N.” stands for Niya, a third- through fourth-century site on the southern Silk Road consisting of a spread-out settlement now in the Takla Makan north of present-day Minfeng. Stein prepared plans of all the houses he excavated there and assigned each a Roman numeral. So, for example, N.XXIV is the twenty-fourth residence he excavated. It can be seen from his plan of this residence (fig. 7) that the house consisted of



FIGURE 6 Wooden document found by Stein at Niya and bearing his inked site signature: N.XXIV.viii.19. Courtesy The British Library, Or.8211/1412(B)

several rooms, which Stein also numbered in Roman numerals, so “viii” is the eighth room of the house. The plan also shows the area where Stein found what he calls the “Hidden Archive”—a cache of wooden manuscripts from which the wooden document shown in figure 6 is the nineteenth he excavated from this cache.

In addition to this coding system, Stein prepared detailed documentation on the Niya site. His expedition report gives several pages of information, for example, about room 8 and the site find (Stein 1921: 226–33), as well as a description of each of the ninety-six documents found there (Stein 1921: 257–62) and a photograph of the room itself (Stein 1921: fig. 61). Recently, scholars have started to exploit this documentation in ways that Stein could not have imagined but that would certainly have delighted him. For example, one scholar has accurately mapped the ancient site of Niya using Stein’s maps and plans overlaid on modern satellite maps using GIS (geographical information systems). Many of the wooden documents name local officials and their roles, and, because the locations of these archives were accurately recorded by Stein, it has been possible to name and locate administrative regions of the ancient settlement and even to identify the houses and names of various government officials (Padwa 2004).

The International Dunhuang Project (IDP) at the British Library is entering all of the documentation from Stein’s expeditions on its freely accessible interactive Web database. It is possible for users to find the exact site of each of the fifty thousand items in the Stein collections and to view Stein’s maps and plans of the sites. The long night hours Stein spent recording the signatures on the documents and surveying the sites were not wasted. Where it is available, documentation from the German expeditions and from others is also being entered online by IDP. In addition to developing its own GIS Web map interface, IDP is using Google

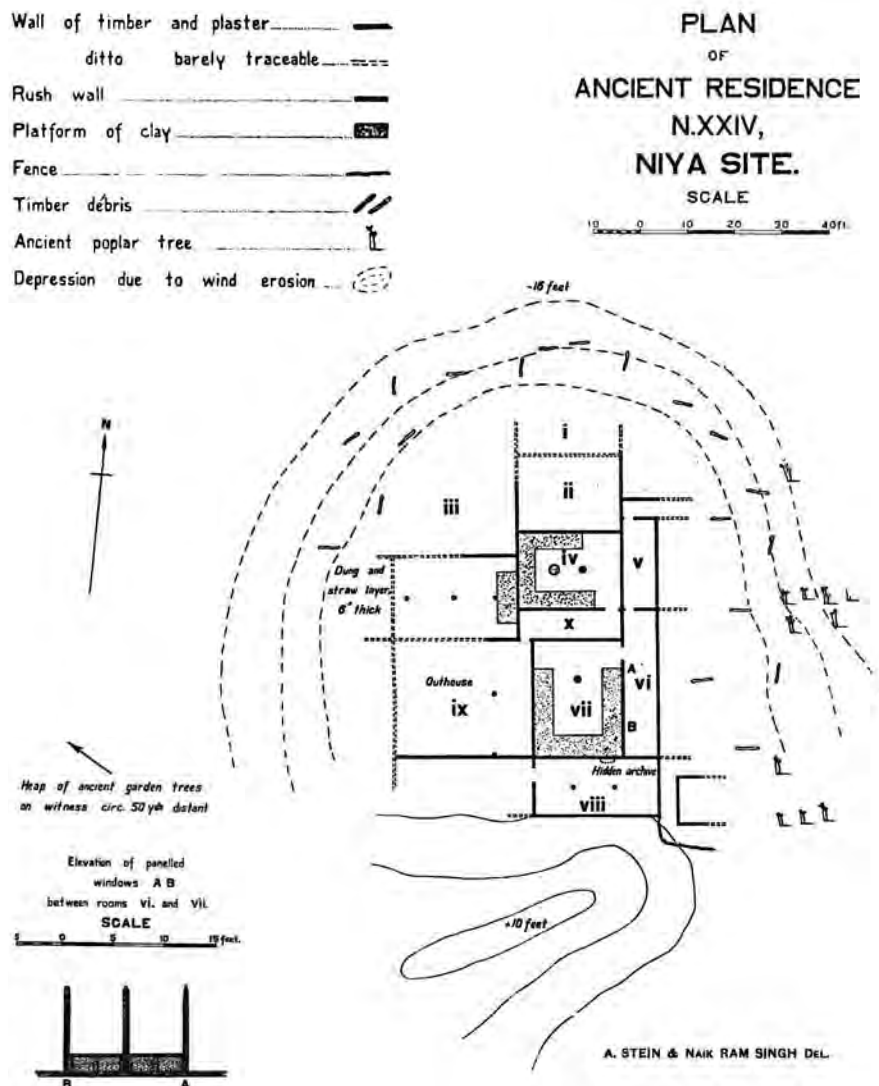

FIGURE 7 Plan of the twenty-fourth residence excavated by Stein at Niya, encoded as N.XXIV.

Earth to overlay the historical maps and site plans prepared by these early explorers.

The Importance of Documentation

Documentation of archaeological activity is essential for housekeeping and tracking the provenance of dispersed collections. As indicated above, all the expeditions to the Turpan region included photography as part of their documentation. The following two examples of documentation aptly illustrate its importance to archaeology. Although Stein was meticulous in keeping written records and plans,

his use of photography was more random, as John Falconer discusses in his paper in this volume. It was Charles Nouette, the photographer on the 1908 expedition of the French sinologist Paul Pelliot (who did not, unfortunately, go to Bezeklik), who stands out as the most assiduous photographer. His 1908 photographs of the Dunhuang caves are of immense value for documentation. For example, the main walls of cave 220 had been overpainted in the Five Dynasties (907–959) and Xixia (Western Xia or Tangut) periods (1036–1226). The overpaintings were removed in the 1940s, probably by the newly founded Dunhuang Research Institute (now Dunhuang Academy). It is not clear whether comprehensive photographs were taken by the institute before the overpaintings were removed, but Ning Qiang, in his recent study of the cave (2004), obviously could not locate any and was forced to refer to Nouette's documentation, specifically, the photograph taken in 1908 to show the "original" paintings of the south and west walls with the overpaintings intact. James Lo, another scholar who realized the documentary value of photography, took a photograph of the south wall in 1943, just before removal of the overpainting (in Ning Qiang 2004: 80–81).

Another example of the importance of documentation to help future generations identify material is that of the artifacts from German museums, mentioned above, taken by the Soviets at the end of World War II. Little was known about this material until 1978, when a large batch was presented to the Grassi Museum in Leipzig by the Soviets. Following Germany's reunification, 55,000 objects were returned to Berlin museums, including several hundred items from the Museum of Indian Art. But this left 1,562 items from the central Asian collections still unaccounted for, including about 100 pieces from Bezeklik (Dreyer, Sander, and Weis 2002). In autumn 2002 the museum's director, Marianne Yaldiz, was invited to the Hermitage to look at crates still containing material removed from Germany. In this preliminary investigation she identified 294 pieces from the Turpan collection. Essential to this identification was the documentation from

the expeditions and from the museum's own archives. As Yaldiz writes:

In 2002 the catalogue of art objects lost in and after World War II was finally completed after several years of intense investigation. Although there were numerous sources, the research involved many difficulties because much of the information in the card indexes and in the inventory books was incomplete. Irreplaceable aids for identification were the original glass plates which remain part of the Museum's photographic archive. Every clue on the identification of the lost objects was taken into consideration however little information it might offer. (2005: 2–3)

Documentation also plays a vital role in preservation, authentication, scholarship, and access. For example, a Japanese team of scholars has digitally reconstructed the wall paintings in Temples 4 and 9 at Bezeklik (Okada and Sakamoto 2007; Shoji et al. 2005). They were able to do this not only because of the documentation helping them to find extant fragments of the original paintings in the various collections worldwide but also because of von Le Coq's publication of high-quality lithographs of the *pranidhi* series, some in color. These showed the large wall paintings that were later destroyed in the bombing of Berlin. For the first time, these digital reconstructions will allow scholars and others to study the temples as a whole. In addition to increasing access to the Bezeklik site, the reconstructed wall paintings are digital surrogates that preserve this art for future generations, no matter what happens to the originals (bearing in mind that care has to be taken to preserve the digital surrogate: as is the case with any form of documentation, the documentation itself has to be documented).

The British Library's International Dunhuang Project is also collating digital documentation of dispersed collections but on a much larger scale. This work provides free Web access to information, documentation, catalogues, and high-quality images of all the finds from Chinese central Asia, including those from Bezeklik.

Of course, just as the original paintings and artifacts need conservation and secure storage to ensure their long-term preservation, so too do digital reconstructions, Web sites, and databases. There remain many questions about long-term preservation of digital data. Experience should tell us that they are subject to the same risks as the artifacts: we cannot guarantee a place—or method—of safekeeping.

However, keeping multiple copies of the data and storing them in different locations is one means of reducing the risk of loss that is not available for the originals. And just as documentation is vital to the identification and recovery of original artifacts, it is no less so for digital artifacts.

Conclusion

The various fates of the Bezeklik murals, both those removed and those left in situ, are a paradigm of the always uncertain and often precarious state of our cultural heritage: we cannot guarantee a place of safekeeping. Custodians of our cultural heritage must, of course, ensure the best and safest possible environment for the long-term preservation of archaeological sites and their artifacts and hope that events out of their control do not conspire to destroy that heritage. But they have an equally important responsibility to prepare detailed documentation and to ensure its safekeeping. Documentation can be kept in multiple copies in multiple sites, reducing the risk of its destruction or loss. This paper has shown how the meticulous documentation carried out by some of the much-criticized archaeologists of the early twentieth century is now being used to identify and bring together dispersed collections and to reconstruct lost finds. It might be all that we have left.

This conclusion has economic implications that are not always considered. All public cultural institutions have limited budgets. No one would deny that providing a stable environment that ensures that cultural artifacts deteriorate as little as possible is of the highest priority for funds. But documentation should be an equally important priority. Excellent work has been carried out by the Dunhuang Academy and the Getty Conservation Institute on the Dunhuang caves in the past decades, including making a full inventory of all the caves, with details of their periods and paintings, and taking environmental measures to prevent further damage from sand and water. But a fully documented, fully accessible, and comprehensive archival photographic record that is stored in several sites is still lacking. With the threat of earthquakes, water damage, deterioration from light, and the deleterious effects of ever-increasing numbers of visitors, this is now needed more than ever. Documentation is time-consuming work and does not yield immediate scholarly recognition. However, as I hope this paper has shown, its long-term impact is greater than any article or monograph and is as essential to preservation as any conservation project.

Acknowledgments

The author would like to thank the curators and conservators at the State Hermitage Museum and the Institute of Oriental Studies in St. Petersburg for information on its Bezeklik collection; Imre Galambos, for reading the archives in Russian; Yoshihiko Okada of Ryukoku University, for information about the Bezeklik materials in Japan and at the National Central Museum in Seoul; Chhaya Haesner, for information about the Aurel Stein collections at the National Museum in New Delhi; and Marianne Yaldiz, for information about the German collections.

Notes

- 1 Temples 4 and 9 were numbered Temples iii and v by Stein.
- 2 www.hermitagemuseum.org/html_En/04/b2003/hm4_1_27.html.
- 3 <http://opac.lib.ryukoku.ac.jp/web/index.htm>.

References

- Andrews, F. H. 1948. *Wall Paintings from Ancient Shrines in Central Asia: Recovered by Sir Aurel Stein*. London: Oxford University Press.
- Blyaher, A. M., T. S. Vasilenko, and L. P. Gagen. 2002. Restavratsiya stennoy rospisi "Pranidhi" iz Bezeklika, vostochnyy Turkestan, v Laboratorii nauchnoy restavratsii monumental'noy zhivopisi Gosudarstvennogo Ermitazha [Restoration of the "Pranidhi" mural from Bezeklik, eastern Turkestan, in the State Hermitage Laboratory for Scientific Restoration of Monumental Paintings]. In *Meeting for Baltic States Restorers: Sacred Art Heritage: Investigations, Conservation and Restoration: 6th Triennial Meeting for Baltic States Restorers: Vilnius, Lithuania, 21–23 November 2002: Preprints*, ed. J. Senvaitiene, 139–41. Vilnius: Lithuanian Art Museum, Pranas Gudynas Restoration Centre.
- Cable, M., and F. French. 1950. *The Gobi Desert*. London: Reader's Union and Hodder & Stoughton.
- Dreyer, C., L. Sander, and F. Weis. 2002. *Museum für Indische Kunst. Dokumentation der Verluste*, vol. 3. Berlin: Staatliche Museen zu Berlin.
- Falconer, J., Á. Kárteszi, H. Wang, and É. Apór. 2002. *Catalogue of the Collections of Sir Aurel Stein in the Library of the Hungarian Academy of Sciences*. Keleti Tanulmányok = Oriental Studies, no. 11. Budapest: MTKA.
- Grünwedel, A., and Preussische Turfan-Expeditionen. 1912. *Altbuddhistische Kultstätten in Chinesisch-Turkistan; Bericht über archäologische Arbeiten von 1906 bis 1907 bei Kuca, Qarasahr und in der oase Turfan*. Berlin: G. Reimer.
- Härtel, H., and M. Yaldiz. 1982. *Along the Ancient Silk Routes: Central Asian Art from the West Berlin State Museums: An Exhibition Lent by the Museum für Indische Kunst, Staatliche Museen Preussischer Kulturbesitz, Berlin, Federal Republic of Germany*. New York: Metropolitan Museum of Art.
- Jia Yingyi. 1990. *Tulufan Bozikelike Shiku. Xinjiang shi ku*. [Urumchi]: Xinjiang ren min chu ban she; [Shanghai]: Fa xing Shanghai ren min mei shu chu ban she.
- Klementz, D. n.d. Notebook from Exhibition 28-1-130, P.12 Ff. Institute of Oriental Manuscripts of the Russian Academy of Sciences, St. Petersburg.
- Klementz, D. A., and V. V. Radlov. 1899. *Nachrichten über die von der Kaiserlichen Akademie der Wissenschaften zu St. Petersburg im Jahre 1898 ausgerüstete Expedition nach Turfan*. St. Petersburg: Akademiia nauk SSSR.
- Le Coq, A. von. 1913. *Chotscho: Facsimile-wiedergaben der wichtigeren Funde der ersten königlich preussischen Expedition nach Turfan in Ost-Turkistan, im Auftrage der Generalverwaltung der königlichen Museen aus Mitteln des Baessler-Institutes*. Berlin: D. Reimer (E. Vohsen).
- Leidy, D. P. 2001. Bezeklik Temple 20 and early Esoteric Buddhism. *Silk Road Art and Archaeology: Journal of the Institute of Silk Road Studies, Kamakura* 7: 201–22.
- Mannerheim, C. G. E., and K. Hildén. 1969. *Across Asia from West to East in 1906–1908*. Suomalais-Ugrilainen Seura. Kansatieteellisiä Julkaisuja, no. 8. Oosterhout, N.B., Netherlands: Anthological Publications; distributed by Humanities Press, NY.
- Ning Qiang. 2004. *Art, Religion, and Politics in Medieval China: The Dunhuang Cave of the Zhai Family*. Honolulu: University of Hawai'i Press.
- Okada, Y., and S. Sakamoto. 2007. Virtual reconstruction of the Bezeklik wall paintings. In *Rong she yu chuang xin: Guo ji Dunhuang xiang mu di liu ci hui yi lun wen ji = Tradition and Innovation: Proceedings of the 6th IDP Conservation Conference*, ed. Shitian Lin and A. Morrison, 259–63. Guo jia tu shu guan shan ben te cang xue shu wen ku. Beijing: Beijing tu shu guan chu ban she.
- Ol'denburg, S. F. 1914. *Russkaia turkestanskaia ekspeditsiia 1909–1910 goda: Snariazhennaia po Vysochaishemu povelieniiu sostoiashchim pod Vysochaishim Ego Imperatorskago Velichestva pokrovitel'stvom Russkim Komitetom dlia izucheniia Srednei i Vostochnoi Azii*. St. Petersburg: Izd. Imp. Akademii Nauk.
- Padwa, M. 2004. Archaeological GIS and oasis geography in the Tarim Basin. *Silk Road* 2 (2).
- Shoji, T., K. Kudara, D. Fujii, and Y. Okada. 2005. VR reconstruction for cave temples. In *Scientific Analysis, Conservation, and Digitization of Central Asian Cultural Properties*, ed. K. Enami and Y. Okada, 129–33. Cultures of the Silk Road and Modern Science, vol. 2. Osaka: Ryukoku University.

- Singh, S. P. 1996. Conservation of central Asian collections in the National Museum, New Delhi, India. In *Dunhuang and Turfan: Contents and Conservation of Ancient Documents from Central Asia*, ed. S. Whitfield and F. Wood, 57–58. British Library Studies in Conservation Science, no. 1. London: British Library.
- Stein, M. A. 1921. *Serindia: Detailed Report of Explorations in Central Asia and Westernmost China*. Oxford: Clarendon Press.
- . 1928. *Innermost Asia: Detailed Report of Explorations in Central Asia, Kan-Su and Eastern Iran*. Oxford: Clarendon Press.
- Yaldiz, M. 2000. The history of the Turfan Collection in the Museum of Indian Art. *Orientalia* 31 (9): 75–82.
- . 2005. A journey of exploration: Objets d'arts of the Museum of Indian Art, Berlin, in the State Hermitage Museum. *IDP News: Newsletter of the International Dunhuang Project, the British Library, Oriental & India Office Collections* 25: 2–3.
- Zhang Guangda and Rong Xinjiang. 1998. A concise history of the Turfan Oasis and its exploration. *Asia Major*, 3rd ser., 11 (2). www.ihp.sinica.edu.tw/~asiamajor/.

Perspectives on Photography's Contribution to Archaeology in Central Asia

John Falconer

Abstract: *Photography's potential as a recording and documentary tool in the field of archaeology was acknowledged almost immediately after the medium became publicly available in 1839. While technical limitations hampered its use and effectiveness in early expeditions, the camera had become a standard item of archaeological field equipment by the end of the nineteenth century. The images surviving in archives and institutions constitute a uniquely valuable resource for present-day archaeologists, scholars, and conservators in illustrating the condition of buildings and artifacts at specific historical periods and in assessing rates of physical change and degeneration. Both the richness of the surviving visual record and its shortcomings in terms of method and comprehensiveness offer lessons to present-day scholars and archaeologists regarding the importance of making detailed photographic records an integral component in fieldwork and on-site conservation projects.*

This paper examines the early history of archaeological photography, with particular reference to its early development in India and in the context of the work of European archaeologists and travelers who converged on the archaeological sites of central Asia in the early twentieth century.

Photography's value to archaeology goes back to the earliest days of photography in the 1840s, when its potential for capturing data rapidly, accurately, and economically was first recognized. Although the early technology presented challenges—cumbersome equipment and complex and demanding processing procedures—within a few decades, the medium had become a standard tool in archaeological fieldwork.

The remarkable speed with which digital technology has advanced in the past decade will undeniably improve the

ease and speed of photographic documentation (and also present new challenges for the preservation, storage, and future accessibility of the digital record). It is probably not rash to assume that photographic film as a reproductive medium will be consigned to history in the foreseeable future.

While there will be major changes in photographic practice technically, it is important to emphasize the continuity of photographic documentation in the century and a half of the medium's existence. An examination of the research value of the existing historical record, specifically, for the study of central Asian archaeology, is also an opportune moment to emphasize the continuing importance of the photographic record for future studies in this field.

Photography and Archaeological Documentation

When photography first became publicly available in 1839, it was hailed with equal enthusiasm as a major new art form and as a tool of unprecedented scientific accuracy, ideally suited to supplant the fallible and subjective hand and eye of the draftsman in antiquarian researches. By the end of the nineteenth century the camera had become an integral tool for the archaeologist.

Among the earliest attempts to use photography for archaeology were the daguerreotypes of Central American sites taken by John Lloyd Stephens, Frederick Catherwood, and Samuel Cabot during their second Yucatán expedition of 1841. However, the technical characteristics of the daguerreotype process hampered publication of the resulting photographs. Most significant was the fact that every daguerreotype—unlike with the negative-positive photographic processes that ultimately superseded the

daguerreotype process—was a unique image produced on a silvered copper plate: multiple copies could be produced only by further photography or engraving. Furthermore, the daguerreotype produced a reflected image in which left and right were reversed. These factors prevented the multiple dissemination of such records, and in any event, these early archaeological photographs were used only as references for the engraver in the published account of the expedition (Stephens 1843). Similar problems plagued a pioneering attempt, financed by the Dutch government in the mid-1840s, to produce photographic documentation of the great Buddhist stupa of Borobodur on the island of Java. Here, the intrinsic technical limitations of the daguerreotype were exacerbated by both the difficulties of working in enclosed spaces in a tropical climate and the extent of the required documentation.

Advances in photographic technology, particularly the negative-positive processes on paper that replaced the daguerreotype, made the use of photography in the field increasingly practical. Some of the finest early results were achieved by a succession of primarily French photographers, such as Maxime du Camp, Félix Teynard, and Auguste Salzmann, who in the late 1840s and 1850s traveled and photographed among the antiquities of Egypt and the Middle East. Although the documentary component of this work remains valuable, its outlook was more embedded in artistic notions of the picturesque than in the emerging demands of archaeological practice. However, by the mid-1850s, the value of photography to archaeology was becoming increasingly recognized and accepted. When, in 1856, Charles Newton led the British Museum excavations at Cnidus and the site of the great Mausoleum of Halicarnassus, at modern Budrum in Turkey, two soldiers from the Royal Engineers were officially attached to the party to record the progress of the work. The several hundred resulting photographs display a clear subordination of the picturesque view to the demands of sober and systematic archaeological documentation.

Archaeological Photography in India

The East India Company, which originated in the seventeenth century as a commercial company trading in Asia, had become by the nineteenth century the effective ruler of much of the Indian subcontinent. These administrative responsibilities led to an increasing awareness of a rich archaeological heritage that by this time was becoming the focus of growing scholarly attention. While the formal establishment of the

Archaeological Survey was not to take place until the 1870s, already by the 1840s the East India Company was becoming aware of its responsibilities in this field and had started to take a positive role in recording the antiquities in India. For example, in 1847 a memorandum from the governor-general instructed the authorities under his control to take an active role in the collection of “really accurate, minute, and well classified information as to the nature, extent, and state of existing monuments” (Governor General in Council 1847). By 1851 the company had sanctioned the employment of an artist to document and make measured drawings of the cave temple on the island of Elephanta near Bombay. By 1854, however, the company was becoming worried by the potential expense of this seemingly open-ended commitment and recommended, on grounds of speed and economy, the use of “photography on paper” as a more efficient recording tool (East India Company 1854).

In the following year, a Bombay army officer named Thomas Biggs, already an experienced photographer, was released from his regular military duties at the request of the Bombay authorities to make a photographic tour of the Dharwar and Mysore districts of southern India, to record the key monuments from the cradle of Hindu temple architecture. Biggs made an impressive start, photographing temples at Aihole (fig. 1), Pattadakal, and other sites in the modern state of Karnataka, but his later report of this work reveals a curiously Victorian notion of the proper function of photography: in this, he drew attention to what he considered the “indecent” nature of some of the sculptures encountered in the Badami district of Dharwar, citing their erotic nature as evidence of the Indian moral decline and decay (a not uncommon response among many European antiquarians of the period, which could then conveniently become a justification for colonial rule). Biggs sought official approval to destroy any obscene sculpture encountered in his work.

Attitudes such as Biggs’s highlight the fact that while lip service was paid to the ideal of creating objectively accurate visual records, early archaeological photography was heavily compromised by a viewpoint that selected for documentation only those sites that were to be included in a canon of Indian art defined and categorized by European scholars. Photography thus became complicit in *creating* as much as *recording* the story of Indian architecture and sculpture. This selectivity was also influenced (in the early days of photography at least) by straightforward technical issues. The difficulties of photography—bulky equipment



FIGURE 1 Durga Temple, Aihole, India, photographed by Thomas Biggs in 1855. British Library, APAC Photo 965/1 (70)

and complex and delicate chemical manipulations carried out in a tropical climate—made large-scale documentation an immensely time-consuming procedure.

The East India Company had been absurdly overoptimistic about how quickly a total photographic record of Indian architecture could be made; company minutes from the 1850s suggest that all worthwhile recording could be completed within a few years. It was many decades before this optimism gave ground to an acceptance of the immense size of the task and a realization of its unending, indeed cyclical, nature. Subsequent experience with photography over the next century and a half demonstrated not only that the documentation was far from complete in India, but that, if it is to be fully and fruitfully exploited, it must be considered a continuing process as buildings are restored or come under threat from decay, pollution, and encroachment.

Biggs's photographic work, terminated by his recall to military duties, was succeeded by further photography projects in the 1850s and 1860s—many of them likewise ambitiously conceived and similarly abruptly terminated as funding ran out or the magnitude of the task became more fully apparent.

The East India Company's lack of administrative clarity in directing such initiatives reflected a corresponding lack of precision in planning and led to much duplication of effort. In the late 1860s, for instance, the India Office, which had taken over the administration of India after the demise of the East India Company, commissioned the commercial

photographer Edmund David Lyon to photograph architecture and archaeological sites in southern India. Drawn to temples and sites whose importance was undisputed, Lyon in fact rephotographed many of the subjects covered by Linneaus Tripe in the course of an earlier official commission in the previous decade, often from almost precisely the same viewpoint, while ignoring hundreds of "lesser" sites. Much of this work was carried out for the benefit of European scholars such as James Fergusson, the great architectural historian of India, who played a major role in defining the areas that should be covered by the Indian authorities, through what later would become the Archaeological Survey of India. For Fergusson and others, photography supplied crucial visual information from sites they were unable to visit personally. The dangers of such an approach are apparent in some of Fergusson's own published work: despite his breadth of personal knowledge, his reliance on the partial evidence from available photographs on occasion led to misidentification and generalization in his analysis of Indian building types.

The Painted Caves of Ajanta

An important example of photography's early service to archaeology in India can be found in the documentation of the Buddhist cave temple of Ajanta. Here, carved from the volcanic rock of the Deccan plateau into the face of a great horseshoe-shaped cliff overlooking the Waghora River, are some thirty *chaitya grihas* (prayer halls) and *viharas* (monasteries), built between the second century B.C.E. and the fourth century C.E., many of them richly embellished with wall paintings and sculpture. The Ajanta caves share similarities with those at Mogao. Both are World Heritage Sites, and, like the paintings at Mogao, Ajanta's paintings are threatened by tourist overload, natural decay, and the mistaken conservation initiatives of the past.

Abandoned in tiger-infested jungle for centuries, the Ajanta caves first came to European notice when a British hunting party stumbled across them in 1819. The fame of the wonderful wall paintings gradually spread as occasional parties visited the caves in subsequent years. The caves gained increased prominence when James Fergusson delivered a paper on them to the Royal Asiatic Society in 1843 (Fergusson 1846). Following this report, the board of directors of the East India Company, on the urging of the Royal Asiatic Society, instructed the Indian authorities to make copies of the cave paintings. Robert Gill, a Madras army officer already known as a talented draftsman with a taste for

adventure, was released from his military duties to carry out this work for long periods between 1844 and 1863. His reports give some idea of the difficulties of such work: many of the caves were so high and dark that copying was impossible without the introduction of strong lights and scaffolding; others were filled with water and mud “and all with the exception of one without ventilation, and the atmosphere tainted and unwholesome, and swarming with ants and bees”; and “one cave ha[d] its entrance on the face of a precipice and [was] accessible only by being let down by ropes from the top” (Gill 1844). Many of the walls also required substantial (and no doubt damaging) cleaning before copying could be attempted. There were additional risks in the form of illness and the presence of marauding bands of robbers in a notably isolated and lawless district. Tragically, most of Gill’s painstaking work perished while on public display in the Crystal Palace at Sydenham, London, in the great fire that destroyed the exhibition hall in 1866.

By this time, however, Gill had taken up photography, and for several years in the 1860s, he lived on-site at the

caves, building up a detailed photographic record of the caves comprising many hundreds of images. Despite an admirable attempt to work to a systematic pattern—all the cave porches, for example, are photographed three times: a head-on view, followed by views of the right and left sides (fig. 2)—the darkness of the interiors, compounded by the grimy state of many of the paintings, prevented the achievement of a comprehensive photographic record. While this remains a fragmentary documentation, of limited use to the modern scholar attempting to re-create the nineteenth-century condition of the paintings, the publication of some of the photographs, accompanied by Fergusson’s text, served to broaden knowledge of both the paintings themselves and their fragile condition (Fergusson and Gill 1864a, 1864b).

FIGURE 2 Stereoscopic interior view of the veranda from Cave II, Ajanta, India, taken by Robert Gill in 1868. British Library, APAC Photo 1000/20 (2062)



Even with the advances in photographic technology over the past century and a half, the technical problems associated with recording such fragile artworks have not been fully overcome. The most recent and in many respects most successful photographic reproductions of the Ajanta cave paintings were made by the Indian photographer Benoy Behl in the 1990s. However, Behl's photographs supply a selective, rather than a comprehensive, record of the cave paintings, and his own account of previous attempts at photographic documentation illustrates the very real difficulties of such work (Behl 1998). Ironically, perhaps the most valuable surviving visual references for Ajanta remain the photographic reproductions of the series of *painted* copies made in the 1870s and 1880s by students from the Bombay School of Arts. If none of these projects can be considered wholly successful, the availability of visual documentation may at least be credited with helping to head off the very real possibility, proposed in 1874, of the wholesale transfer of the paintings to a more accessible museum location, "where all the antiquarian and artistic world could see them" (Terry 1873).

Archaeological Survey of India

Following hesitant initiatives to establish an archaeological survey in the 1860s, the activities of individual scholars, government employees, and learned bodies such as the Royal Asiatic Society had created the momentum that led to the formal establishment of the Archaeological Survey of India in 1871 under the director-generalship of the military engineer Alexander Cunningham. From the survey's inception, photography was considered an integral tool for the fieldworker. This was to be strikingly illustrated by the end of the decade, when the young and inexperienced Henry Garrick was appointed archaeological assistant to the survey in preference to a candidate better qualified in the field, on the grounds that "as he is both a good photographer and a good draughtsman, he already possesses two valuable qualifications for an archaeological assistant" (Cunningham 1880). While archaeological experience would no doubt develop over time, the demands of accurate record taking were of immediate importance to the survey. From this time onward, the photographic recording of archaeological sites became a central task of India's Archaeological Survey.

Limitations of the Photographic Record

The photographic documentation of Indian architecture in the late nineteenth century resulted in the most detailed

visual record of the archaeological and architectural heritage of any Asian country during the period, but it was far from being totally successful either in conception or in execution. At the very least, the work reflected a lack of clarity regarding what precisely photography might be expected to achieve in this field. This matter was the subject of some debate among scholars throughout the last half of the nineteenth century: Was photography meant to produce an illustrative sample of major building types—a gallery of representative masterpieces for use by scholars as reference material? Or was it intended to function as a more objective archive, with the aim of creating a comprehensive and detailed record of the material remains of a whole subcontinent, uncontaminated by popular views of scholarly fashion? Or was its most important use to provide an accurate record of structures, inscriptions, and works of art that were rapidly falling into decay or in imminent danger of destruction?

It is also worth noting that the threats of industrialization and urbanization to the historical built environment were of major concern even in nineteenth-century India. The distinguished archaeologist and photographer Henry Cousens, for example, noted when visiting the site of the ancient city of Chandravati in Gujarat in 1890 that almost all of the magnificent shrines and sculptures that had so impressed visitors since its European rediscovery in the early 1820s had, over the course of the previous decade, been broken up by railway contractors to make ballast for bridge foundations or burned to make lime (Cousens 1890).

During the late nineteenth century, the balance between the various points of view on the role of photography was constantly shifting, influenced by financial considerations, scholarly debate, and the development of archaeology from an antiquarian pastime into a formal academic discipline.

Aurel Stein's Photographic Legacy

In the course of three major expeditions to Chinese central Asia in the early decades of the twentieth century, the archaeologist Aurel Stein (fig. 3) compiled an extensive photographic record of his travels comprising several thousand images. Stein's use of photography in his work served several functions and forms a vivid reflection of the breadth of his scholarly interests and achievements. In addition to using photography to illustrate the course and content of his archaeological investigations, Stein employed it to document his geographic, topographic, and surveying work (Stein 1908; Stein, Mason, and Hunter 1923); to make records

FIGURE 3 Aurel Stein with Indian assistants and excavators at the ruined city of Kara-khoja, Xinjiang (Third Central Asian Expedition, 27 January 1915). British Library, APAC Photo 392/29 (242)



of his ethnographic research in the field; and, not least, to create a visual narrative to accompany the published accounts of his journeys.

As described above, the second half of the nineteenth century saw the creation by travelers, explorers, and scholars of a huge volume of visual records of ancient sites. Stein's use of photography is best viewed against this tradition of archaeological photography that had developed in the Indian subcontinent, in particular, through the Archaeological Survey of India, which had employed Stein when he first started to use the camera. It was within this framework that Stein's own archaeological, and indeed photographic, practice was grounded and formed.

Stein had first come to India in 1888 as principal of the Oriental College at Lahore in present-day Pakistan, but he soon became heavily involved in archaeological research and made a number of field trips during the 1890s, before joining the Archaeological Survey of India as superintendent of archaeology in the North-West Frontier Province and Baluchistan (now Balochistan province of Pakistan). It was while officially holding this post, between 1904 and 1910, that Stein undertook his second central Asian expedition (1906–8).

Stein had first taken up photography during his early field trips in the 1890s, receiving his initial training in the craft from his lifelong friend Fred Andrews, vice-principal of the Lahore School of Art and later his assistant in organizing and listing the collections brought back from central

Asia. He continued to improve his technical competence during his work with the Archaeological Survey of India, in which photography had occupied an important if fluctuating position for half a century, and it is clear that during this period, he absorbed a growing appreciation of its value as a documentary tool. In the course of his three most important archaeological expeditions to central Asia (1900–1901, 1906–8, and 1913–16), Stein used photography to record archaeological sites and finds, the landscapes and settlements through which he traveled, and the people whom he encountered.

Apart from his small and trusted team of Indian surveyors (who also received some basic photographic training), all of Stein's expeditions were of a largely solitary nature—a situation that certainly reflected personal preference as much as economic necessity. Despite Stein's logistical and administrative efficiency, allied to a formidable intellectual and physical energy that characterized all of his professional undertakings, some areas of his work were inevitably limited. The demands of archaeological fieldwork, exploration, mapping, and writing left insufficient time to create a comprehensive photographic documentation of individual sites. His photography of his major excavations at the sand-buried settlement of Niya, on the southern Silk Road, for instance, consists of general views of the area and some closer studies of excavated artifacts. While striving to give an overall impression of the site for future publication, Stein clearly had insufficient time to create a fully detailed photographic record of each stage of the dig.



FIGURE 4 Aurel Stein photograph of mural at a Buddhist shrine in Miran, Xinjiang (Third Central Asian Expedition, 21 January 1914). British Library, APAC Photo 392/29 (81a)

The breadth and technical quality of what Stein did achieve with the camera during his Asian travels are nonetheless remarkable. Although he kept abreast of the latest advances in technology, much of his photographic work was undertaken using heavy cameras and glass plates with relatively slow emulsions. The physical limitations of the number of plates that could be taken on long expeditions and the consequent need to ration their use were additional mundane factors influencing what could be achieved. Stein would certainly have acknowledged the value of a fuller record for the archaeologists, scholars, and conservators who followed in his footsteps. However, given the remarkably heavy workload of his expeditions, the additional physical and technical demands of photography should not be underplayed. Some flavor of these burdens can be appreciated by Stein's own account of his attempts to photograph the frescoes he discovered among the Buddhist shrines at Miran, on the southern Silk Road in present-day Xinjiang. Here technical difficulties were compounded by the bitter winter climate of the desert in January 1907:

To do justice to the harmonious and often faded colours of these paintings with a camera would have taxed the skills of a professional photographer working with special plates and appliances in his studio. But for an amateur like myself, the conditions under which the work had to be done were almost prohibitive. It was sufficiently difficult to squeeze myself

in my bulky fur kit into a position low and distant enough to photograph a frescoed dado just above the floor and on the curving wall of a passage barely seven feet wide. For days the dust haze raised by the violent winds made the light so poor that prolonged exposure was needed, with the attendant risk of seeing the result spoiled by the camera shaking in the gusts. To examine the correctness of the negatives so exposed would have required development of each plate on the spot. But in the intense cold still prevailing this could not be done at night without risk of the plate freezing while drying in the tent. In order to reduce the risk of total failure I laboriously took several complete rounds of the frescoes with varying light and exposure,—only to find in the end, when development became possible, some four months later, that my efforts had failed to secure an adequate record. (Stein 1912, 1:493–94)

The images Stein took of these murals, technically unsatisfactory though they may be, are now the only remaining evidence of these paintings, the originals having been destroyed in later rash and misguided attempts to remove them (fig. 4).

At Dunhuang itself, Stein's photographic documentation of the Mogao Caves was undeniably meager (figs. 5, 6), and it is clear that his other activities left insufficient leisure for the creation of a fuller visual record. That Stein himself was aware of the scholarly importance of such photographs



FIGURE 5 Aurel Stein photograph of shrines near the center of the Mogao Grottoes (Third Central Asian Expedition, 3 April 1914). British Library, APAC Photo 392/29 (105)

and of the shortcomings of his own work in this area is implicit in his remark that “the camera can be employed [at Dunhuang] with great archaeological profit for weeks if not months” (Stein 1907).

The very limited and selective nature of Stein’s photographic record of the caves at Dunhuang is evident when it is compared with that produced by the Russian expedition to Dunhuang led by Sergei Oldenburg in 1914–15. Among the members of Oldenburg’s group, which remained at the site for some six months, were artists, surveyors, topographers, and a photographer, Samuil Dudin. The inclusion of a photographer gave this expedition the opportunity to create a far more systemic documentation of the caves than Stein could have hoped to achieve. The final product of the Russian work



FIGURE 6 Aurel Stein photograph of caves opposite Hoshang’s quarters at the Mogao Grottoes (Third Central Asian Expedition, 3 April 1914). British Library, APAC Photo 392/29 (106)

comprises more than two thousand individual photographs, including a thorough record of the cave facades. For selected caves, as many as fifty views were taken to present a full record of both their structural formations and the paintings and sculpture that adorned them. The Oldenburg expedition’s photographic documentation of the Mogao Grottoes, taken more than ninety years ago, remains the most comprehensive record so far attempted, and the fact that it has not been superseded emphasizes how logistically complex, physically demanding, time-consuming, and often remarkably tedious such work can be. Regrettably, for the remainder of the twentieth century, this painstaking documentation remained largely inaccessible in the collections of the Hermitage Museum in St. Petersburg, although a representative selection of images has now been published (Fan Jinshi and Cai Weitang 2000).

The incompleteness of Stein’s photographic output was more than offset by the accuracy of the accompanying documentation: throughout his career, Stein scrupulously recorded every aspect of his photographic work in a series of uniform notebooks, listing date, subject, and other technical details (fig. 7). In contrast is the magnificent series of negatives made by the German expeditions under Albert Grünwedel and Albert von Le Coq to the Turpan region of the northern Silk Road between 1902 and 1914. While of superior photographic quality, these images are almost

Date	No. of Slide	Plate or Film	Time of Day	Light	Stop	Exposure	Subject, notes on lighting, etc.	No. of Negative
4/1/14	8	NW G22	9:30	br.	16	1/3	Ruins at entrance of S. group - afiq: seen from S.	good
	9	G22	10	br.	16	1/3	Interior of 2nd ruined mound top in S. group - afiq: top of (a tower)	ext.
	10	G21	12	br.	16	1/4	Chikka-kol ruins, N. group of I. seen from S.W.	ext.
	11	G11	1:30	br.	16	1/6	Chikka-kol I & II groups seen from E. across marsh	good over
4/1/14	12	G13	12	br.	16	1/6	View low N. from S. most top dome of G. N. group. Kosh gumbaz	good over
6/1/14 0157	2	SW	2	br.	16	1/2	Largest tomb III. N. group. Kosh-gumbaz, seen from SW	over ext.
0160	2	"	"	"	"	1/2	S. (smaller) group of tombs, Kosh gumbaz seen from SE.	over
0158	2	"	2:30	br.	16	3/4	Large tombs in SW corner of S. (smaller) group of Kosh-gumbaz seen from S.E. (Khalid)	ext.
8/1/14	8	"	1	br.	16	1/8	Ruins to SW of Chikka-kol seen from S.W. near Kao IV.	over
	9	"	1	br.	16	1/4	Ruin large, NW of Kao IV (labourers in room)	over
11/1/14 0179	3	"	1	br.	16	1/6	Kao I. ii & ruins N of it from Kao I. i	ext.
15/1/14	1	NW G34	1:30	br.	16	1/8	Toiyuk houses by tombs from SW. (houses in foreground)	
	2	G33	2:30	br.	11	1/2	Home of Niqadaya, street in Toiyuk	

FIGURE 7 Page from Aurel Stein's notebook documenting photographs taken at Kara-khoja and Toyuk, Xinjiang (Third Central Asian Expedition, November 1914). British Library, APAC Photo 392 Notebook 3 (1914)

entirely lacking in supporting documentation as to date, location, or subject. Their value to the modern researcher is consequently severely diminished.

Henry Cousens's Photographic Achievements

By the end of the nineteenth century, the importance of comprehensive visual documentation produced to rigorous standards was becoming recognized by a few farsighted individuals, most notably Henry Cousens in his work at the great Buddhist stupa at Sanchi, some 40 kilometers from Bhopal, in the Indian state of Madhya Pradesh. In order to photograph the extensive sculptural panels that adorn this World Heritage Site, Cousens built an elaborate wooden framework that allowed him to raise his camera parallel to each section and to photograph each individual relief without distortion and to a uniform scale. (A full description of his working method can be found in his *Annual Report for 1900* [Cousens 1901].) This task, which took Cousens and his team of assistants over two months to complete and which resulted in a collection of over 250 large-format negatives, remains a model of its kind. It further illustrates the financial and time

commitment required to produce fully satisfactory visual records of archaeological subjects. While such an approach has historically been the exception rather than the rule, it remains an enduring model of photography's unique value as a tool of record in its comprehensive scale, carefully planned organization, and technical quality.

Conclusion

Growing awareness of the unique documentary value of the photographic record has led to the accumulation of an immense and varied archive in the century and a half of the medium's existence. In many cases, photographs constitute the sole surviving visual record of structures and sites that have succumbed to time, neglect, misguided conservation, political events, human greed, and simple vandalism. For all its value, much of this existing record is frustratingly incomplete, often produced with little thought to the likely demands of future research or conservation. In addition, the technical limitations and expense of photography in its early days tended to work against the ideal of comprehensive documentation. For many important structures and sites,

which have changed immeasurably (both themselves and the surrounding environment) over the succeeding century, the incompleteness of the visual record represents a significant missed opportunity. While we pay tribute to the importance of the visual record created by pioneering archaeologists who first uncovered the riches of Buddhist art in central Asia, the shortcomings and often frustrating omissions in the surviving documentation cannot but reinforce the crucial importance of the photographic record both to present-day field-workers and to future scholars.

Advances in photographic technology—not the least of which is the recent development of digital media—have made an immense difference to what can be achieved in creating a photographic record. If the challenge to create full and comprehensive photographic records of archaeological sites from the moment of discovery, produced to agreed standards, were to be embraced by field-workers, there is little doubt that this would earn the gratitude of future researchers. However, the magnitude of the task of creation, organization, and dissemination of such documentation should not be minimized.

References

- Behl, B. K. 1998. *The Ajanta Caves: Ancient Paintings of Buddhist India*. London: Thames and Hudson.
- Cousens, H. 1890. *Progress Report of the Archaeological Survey of Western India for the months December 1889 to February 1890*. Bombay: Government of Bombay, General Proceedings (Archaeology).
- . 1901. *Archaeological Survey of Western India: Annual Report for 1900*. Bombay: Government of Bombay, General Proceedings (Archaeology).
- Cunningham, A. 1880. Letter from Alexander Cunningham, Director-General of the Archaeological Survey of India, to the Under Secretary to the Government of India, dated 29 September 1880. Government of India, Home Proceedings (Surveys), vol. 1501.
- East India Company. 1854. Despatch from the East India Company to the Government of Bombay. Bombay Public Despatches, 14 June 1854.
- Fan Jinshi and Cai Weitang. 1997–2005. Photos of the Mogao Grottoes. In *Eluosi guo li Ai'ermitashi bo wu guan cang Dunhuang yi shu pin = Dunhuang Art Relics Collected in the State Hermitage Museum of Russia*. Gosudarstvennyi Ermitazh (Russia), and Shanghai gu ji chu ban she, vols. 3–4. Shanghai: Shanghai gu ji chu ban she.
- Fergusson, J. 1846. On the rock-cut temples of India. *Journal of the Royal Asiatic Society of Great Britain & Ireland* 8: 30–92.
- Fergusson, J., and R. Gill. 1864a. *One Hundred Stereoscopic Illustrations of Architecture and Natural History in Western India*. London: Cundall, Downes.
- . 1864b. *The Rock-Cut Temples of India Illustrated by Seventy-Four Photographs Taken on the Spot by Major Gill*. London: J. Murray.
- Gill, R. 1844. Letter from Robert Gill to the Secretary to the Government of Madras, 23 November 1844. India Office Records (British Library), Board's Collections, IOR/F/4/2164 (104569), ff. 25–27.
- Governor General in Council. 1847. Minutes from the Governor General in Council, Public Department Proceedings, dated 27 January 1847.
- Stein, A. 1907. Letter from Aurel Stein to Percy Allen. Mss. Stein 4/58, Bodleian Library, Oxford University.
- . 1912. *Ruins of Desert Cathay: Personal Narrative of Explorations in Central Asia and Westernmost China*. London: Macmillan.
- Stein, A., K. Mason, and J. de G. Hunter. 1923. *Memoir on Maps of Chinese Turkistan and Kansu: From the Surveys Made during Sir Aurel Stein's Explorations, 1900–1, 1906–8, 1913–5*. Records of the Survey of India, vol. 17. Dehra Dun: Trigonometrical Survey Office.
- Stein, M. A. 1908. *Mountain Panoramas from the Pamirs and Kwen Lun, Photographed and Annotated*. London: Royal Geographical Society.
- Stephens, J. L. 1843. *Incidents of Travel in Yucatan*. London: John Murray.
- Terry, G. W. 1873. Letter from G. W. Terry, Principal of the Jamsetjee Jeebhoy School of Art, Bombay, to the Chief Secretary of the Bombay Government, dated 5 December 1873. Bombay Home Proceedings (Public), May 1874.

Harps on the Ancient Silk Road

Bo Lawergren

Abstract: *One can derive a great deal of information on Chinese music from images painted during the first millennium along the Silk Road, including Dunhuang, especially if combined with Chinese texts. Long before the arrival of Buddhism in China, music held an important place in Confucian and Daoist ritual. With the arrival of Buddhism, its followers demanded no less, but they required instruments quite different from the ritual instruments used during the first millennium B.C.E.—bronze bells, stone chimes, and large drums. The instruments brought by Buddhists were light (lutes, harps, flutes, reed instruments, and small drums). Most survived in China, but harps (konghou) disappeared shortly after 1000 C.E. as Buddhism declined. One of the last depictions of harps is found in cave 465 at the Mogao Grottoes (thirteenth century).*

This paper attempts to compile what is known about these ancient instruments, information vital to conservators, art historians, instrument makers, and musicians who wish to revive earlier practice. Harps died out in China, but replicas are now played in several places, for example, the Dunhuang Academy, the Shanghai Conservatory, Jeonju (Korea), and Tokyo.

Although harps were not indigenous to China, they came to play an important role there during the first millennium C.E. after migrating along the Silk Road from India, Iran, and points farther west. Many types of Western instruments came the same way. All were lightweight and could easily be transported on camels, horses, and other beasts of burden. Images of these instruments were painted on walls in caves and grottoes on the Silk Road, notably at Dunhuang, and the images reveal shapes and playing positions of instru-

ments, their formation into orchestras, and their cultic and societal function. The information is occasionally supplemented by Chinese texts.

At the beginning of the first millennium B.C.E., Chinese ritual relied mostly on heavy bronze bells and weighty stone chimes. Both were indigenous and lacked parallels in the West. There were few if any string instruments (zithers may have been used, but there is no information). At the same time, Chinese music employed an extensive variety of drums, many of them large. Their massive size confined them to fixed stationary positions during performance.

In ancient western Asia, for example, in Mesopotamia and Iran (Lawergren 1995, 2001), the situation was different. From the earliest documented time, string instruments dominated, with harps, lyres, and lutes already being played in the third millennium B.C.E. Not only were string instruments more numerous there than in China, but they also had a greater diversity of shapes. Moreover, players were sometimes depicted standing and were anything but stationary.

None of these types of light instruments existed in China; conversely, no zithers were known in the West. Western countries were unaware of other Chinese favorites, such as heavy bells and stone chimes. Most Western drums were small, unlike Chinese ones.

This situation changed when the Silk Road opened a window toward the West and its ample supply of string instruments. Buddhist travelers on the Silk Road not only introduced their faith to China but also brought light instruments for their rituals.

The sacred texts of Buddhism compelled China to import Western instruments. Mahayana sutras were written as if Western instruments were the norm. Texts recounting

the life of Siddhartha, the young prince who grew up to become the Buddha, describe how in his father's palace the prince enjoyed the company of the female musicians employed there, and he liked listening to their harps, lutes, flutes, and drums (Lawergren 1994a: 226, 227–28). A still grander orchestra described in the Lotus Sutra includes drums, horns, conch shells, pipes, flutes, zithers, harps, lutes, cymbals, and gongs (trans. A. Berkowitz, pers. com.; Watson and Kumarajiva 1993: 40). Individuals who assembled such orchestras—the sutra promised—would attain Buddhahood.

Music was also featured in the sutras that describe future delights of paradise awaiting devout Buddhists. There would be “music, concerts, and musical instruments,” and worshippers would have access to an assortment of “materials, beginning with flowers and ending with musical instruments” (Cowell et al. 1969: 53). Since the music of Western instruments was a pleasure approved for the afterlife, why not enjoy it already here on earth?

Many light instruments were introduced into China, but this paper focuses on harps. Before Buddhism entered China, harps were unknown there; after the first millennium C.E.—when Buddhism sharply declined—harps disappeared for good. One of the last depictions of a harp is in Mogao cave 465 of the thirteenth century. Later images exist, for example, in Qiu Ying's large hand-scroll *Spring Morning*

in the *Han Palace* (Fong, Watt, and Guo li gu gong bo wu yuan 1996: pl. 203 [central section]). It was painted in 1540 but seems to depict much earlier conditions.

Harps in Ancient China

The harp (*konghou*) was the quintessential Buddhist instrument of China. These instruments had several distinct forms, most of them depicted in the wall paintings of grottoes and caves near Dunhuang. I recognize four categories of harps: arched, angular, vajra, and steppe. The first two are the oldest. The arched harp arose in the Iraq-Iran region around 2900 B.C.E. and was replaced around 1900 B.C.E. by the angular type, which soon became ubiquitous in western Asia, Egypt, and the eastern Mediterranean region. But the arched type had apparently already gained popularity in India, during the Indus civilization. Figure 1 depicts an arched harp and an angular harp based on Egyptian depictions (Lawergren 2001: figs. 2m, 3g), but their structure is similar to that of harps illustrated millennia later in China. In other words, harp designs remained stable for extraordinarily long durations. Arched harps (fig. 1a) have a long, curved rod projecting out of the short side of the sound box. Strings are attached to tuning collars, which, when rotated around the rod, tune the strings. The other string ends are tied to a narrow rib in contact with the membrane that covers the

FIGURE 1 Harps from ancient Egypt: (a) arched harp (1340 B.C.E.); (b) angular harp (early eighth century B.C.E.).

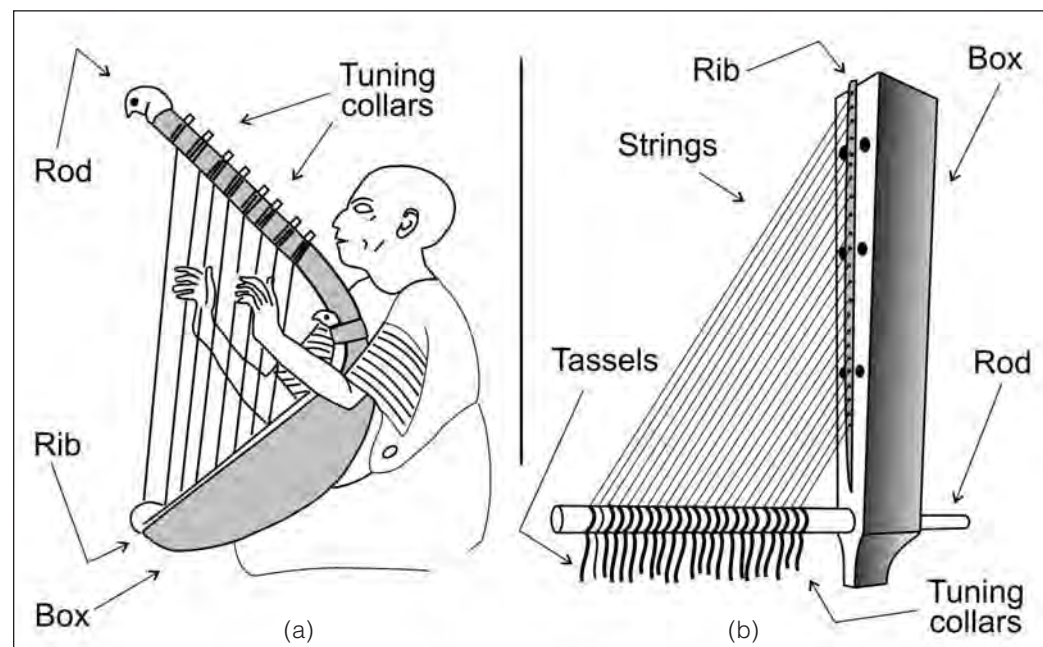



FIGURE 2 Depiction of an arched harp from the Mogao Grottoes (cave 327).

box. Angular harps (fig. 1b) have the same individual components, but they are arranged differently. For example, the rod joins the box perpendicular to its axis through a wide hole, and the box is placed above the rod rather than below it.

During the period immediately prior to the opening of the Silk Road, arched harps existed only in India, and the angular harp in Iran and regions farther west. Most Silk Road sites depict only angular harps; the largest exception is at the Kizil grottoes (near Kucha, Xinjiang Autonomous Region, China), where 75 percent of the harp images are arched (Lawergren 1995: table 1, no. III 1). At the Mogao Grottoes near Dunhuang, 10 percent of the harp images are of the arched variety, the highest number after Kizil. Farther east into China there were no arched harps. Since the two instrument types came from distinct geographic regions, the percentages reveal distinct musical influences. The large percentage of arched harps at Kizil indicates substantial Indian influences. A dominance of angular harps points to influences from Iran or regions farther west.

Arched Harps

Before the Silk Road became active, arched harps were found only in India. From there they migrated north into Gandhara (near present-day Kabul, Afghanistan), Bactria (near Balkh, northern Afghanistan), and Sogdia (near Samarkand, Uzbekistan). An example from Panjikent (western Tajikistan) is a small, portable harp with seven strings and a bird's head at the upper end of the curved rod (Lawergren 1995: fig. 3c). What is unusual about this

depiction is that the player holds a rectangular plectrum in her left hand and damps the strings with her right hand, a reversal of normal hand positions. Players depicted in wall art in Kizil and Bezeklik (about 30 kilometers east of Turpan, Xinjiang) pluck with their right hands. Their harps have slender rods that swoop out of the box in long arched curves.

The arched harps depicted in two caves at Mogao, cave 327 (fig. 2) and cave 465 (shown in Blunden and Elvin 1983: 111), were drawn nearly a millennium later than those at Kizil. These represent the most easterly diffusion of arched harps (Lawergren 1995: 270, table 1, No. I).¹ The Dunhuang harps and the one in cave 438 at Bezeklik (Yao Shihong 1983: 243) are decorated with bird heads, but these are not unique. Animal heads on arched harp rods are also present at Panjikent (Lawergren 1995: fig. 3c) and two millennia earlier in Egypt (fig. 1a).

The unusually late painting (thirteenth century) of the arched harp in Mogao cave 465 (Blunden and Elvin 1983: 111) contains Tibetan traits. Although the harp is not clear, the S-shape of the rod is plainly visible. A similarly shaped rod was used on another Tibetan harp, that at Alchi (see below).

Angular Harps

The history of angular harps is more complex than that of arched harps. Until about 550 C.E. angular harps maintained the sturdy construction acquired around 1900 B.C.E. in Mesopotamia (fig. 1b). But after 550 C.E. they became instruments of great delicacy and mechanical elegance. The box

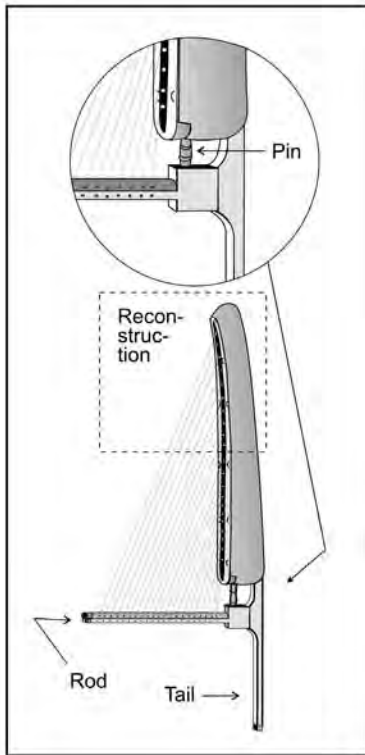

FIGURE 3 An extant cantilever harp in the Shosoin Treasure House in Nara, Japan.



FIGURE 4 In this image from Khocho, 50 kilometers southeast of Turpan, the player's arm obscures the pin of his harp, making it difficult to determine if it is an angular harp or the cantilever variant.



FIGURE 5 Depiction of a cantilever harp from the Mogao Grottoes (cave 156).

no longer reached down to the level of the rod, and the two parts could no longer support each other. Instead, the rod was attached to a slender tail that descended from the box. To achieve balance, a pin was inserted between the box and the rod. In other words, the rod had become a cantilever projecting beyond a fulcrum (the pin) and supported by a balancing force from the tail. Figure 3 shows an extant harp in the Shosoin Treasure House in Nara, Japan, which clarifies this construction (Lawergren 1995: fig. 4f). It is dated ca. 800, but earlier examples are depicted in Iran and on the Silk Road. I shall call this variant of the angular harp pattern a “cantilever harp.” Elegance was gained by the new design, but strength was sacrificed. Unfortunately, it is sometimes difficult to identify such harps in paintings because the player's right arm may obscure the pin (e.g., fig. 4).

At Dunhuang one finds harps with and without a fulcrum pin, as well as some harps that are difficult to classify. At first glance the harp in figure 5 seems an obscure type, but

the spacing of box, rod, and tail suggests they were joined in a cantilever design.

Angular harps became common throughout China. Buddhist orchestras had them, and so did entertainers, virtuosos, and poets. During the Sui and Tang dynasties (581–907 C.E.), female central Asian musicians were in especially strong demand in China, and they frequently modeled for terracotta and porcelain figurines (e.g., Lawergren 1995–96: fig. 10). Among poets favoring the harp, we note Li He (791–817), active in the Tang dynasty capital of Chang'an. One poem describes a harp concert given by the court musician Li Ping (Frodsham, David, and Li Ho 1970: 10–11). The air is cool; it is an autumn day with low clouds and dew on the ground. The poet sees the clouds move nearer to the musician and imagines they wish to hear the harp better. But rain begins to pour, and the harp moans. When a rainbow appears, it is as if the sound had shattered jade and vaporized minerals, which spread across the sky. Earth and heaven quiver, fish jump, dragons

dance, phoenix-birds shriek, and the light melts before the city gates of Chang'an. Nature and harp had become one.

Other Harps

A third type of instrument, the vajra harp, appeared in China at the time when arched and angular harps were about to disappear, shortly after 1000 C.E. Most of the evidence for this harp comes from Japan, but similar harps are shown on images not far from Dunhuang. Recently a fourth type of instrument, the steppe harp, has been brought to light by archaeologists working in Xinjiang—again, not far from Dunhuang. This harp, however, appeared before the opening of the Silk Road and does not seem to have penetrated east of Xinjiang. Like other harps, both types came from the West.

Vajra Harps

A typical early vajra harp is shown in figure 6. It was drawn about 1125 on a raigo painting (a type of Japanese painting that depicts the descent of Amida, the Buddha of Infinite Light, accompanied by scores of musicians) that now hangs in the Reihokan Museum, Koyasan, Japan (Lawergren 2008). The instrument has a flat, cylindrical, and horizontal body that supports an undulating vertical rod holding six nearly vertical strings. The assembly is crowned by a three- (or four-) pronged vajra (an object representing a thunderbolt). The vajra, an implement used in esoteric Buddhist sects in China and Japan (Louis-Frédéric 1995: 63–67), lends a sacred aura to this harp. On later raigos (twelfth–seventeenth century) the body and rod of the vajra harp are greatly simplified and do not appear to be functional. The cylindrical body has been replaced by a horizontal stick, and the strings have disappeared, but the vajra remains. Evidently, the religious symbolism of the vajra was more important than the musical efficacy of the instrument. Thus this was a symbolic harp rather than a musical one. There are no vajra harps in the Shosoin Treasure House, a place otherwise well supplied with musical instruments of the late first millennium. The absence is hardly surprising.

In Japanese Buddhism, raigo paintings express a belief in the Pure Land, a far-off region that offers marvelous delights to the righteous Buddhist after death. It is a paradise, and Buddhist paintings show it with sumptuous buildings, spacious gardens, refreshing pools, large orchestras, pliant dancers, and blessed inhabitants. Buddha Amida, who presides over it, is attended by two bodhisattvas, Seishi and Kannon. Raigo paintings show the three descending to receive the spirit of a deceased man and bring it back to the

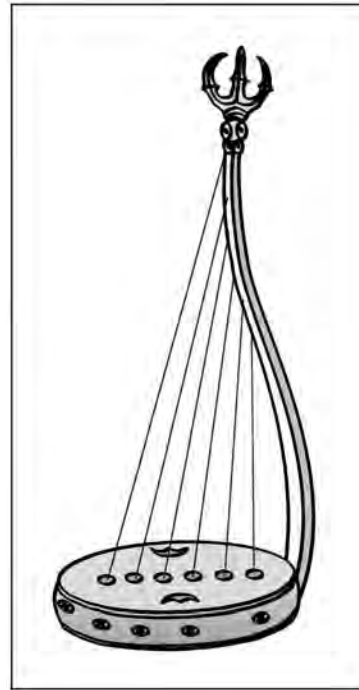

FIGURE 6 Depiction of a vajra harp on a raigo painting. (Reihokan Museum, Koyasan, Japan)

Pure Land. The occasion is of great musical interest as musicians accompany Amida, and their instruments—including a vajra harp—are usually carefully drawn. This type of painting was unique to Japan—as was the harp. However, evidence of the existence of a variant of the vajra harp is found in China (discussed below).

Vajra harps were depicted centuries before one appeared on the Koyasan raigo, namely, on the Diamond World mandara, or *kongokai* (Lawergren 2008), which is a pictorial representation of concepts and doctrines fundamental to Shingon and Tendai Esoteric Buddhism (ten Grotenhuis 1999: 33–57, figs. 20, 23, pls. 6, 7). The earliest surviving polychrome copy of this mandara, from the ninth century C.E., is kept in the Toji temple in Kyoto, but later copies are very similar. The vajra harp is placed at the upper left side (ten Grotenhuis 1999: 80–86), in a section that contains many other objects outfitted with vajras. Presumably, the harp was given its vajra because of the environment on the mandara. The original Diamond World mandara had been given to the Japanese monk Kukai when he visited the Chinese capital Chang'an in 804–5 (Lawergren 1995: 247). Many copies of the mandara have survived in Japan but none in China. The vajra harp is the only musical instrument represented on the mandara. It rests unplayed on a lotus pod. So even here it is a symbol rather than an active instrument.

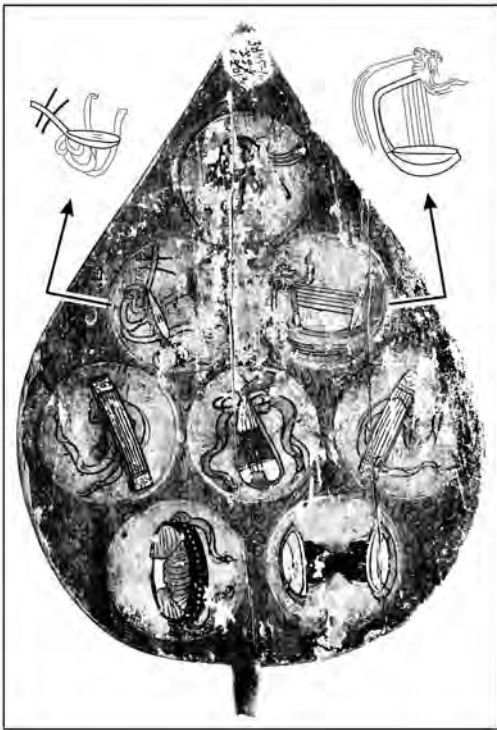

FIGURE 7 Musical instruments depicted on a wooden plate from Kharakhoto, Inner Mongolia. Arrows point to a phoenix harp (right) and an arched harp (left). State Hermitage Museum, St. Petersburg, Russia, inv. no. 3845-1a

As mentioned earlier, a related instrument—without the vajra—was depicted in central China and in regions farther west around the beginning of the second millennium C.E. A comprehensive Chinese treatise on music published in 1104 C.E. by Chen Yang (1979; Lawergren 1995: fig. 3F) illustrates this harp, but a phoenix head replaced the vajra. The alteration replaces Buddhist associations with ancient Chinese ones. Quite likely, Chen Yang's instrument and the vajra harp had a common source in central China or west of it. The surmise is supported by two further examples, both from the West. The first comes from Kharakhoto, western Inner Mongolia, which at the time (1000–1200) belonged to the state of Xixia, where Buddhism was the state religion (Piotrovsky 1993: 55–57). The second is in a Buddhist temple at Alchi, about halfway between Leh and Khatatse in the Indian state of Jammu and Kashmir. Russian excavations at the Kharakhoto site produced a thin wooden plaque carved and painted to look like the leaf of a bodhi tree (Zuber 1940: pl. 6). The plaque, dated 1200–1400, has sixteen images of

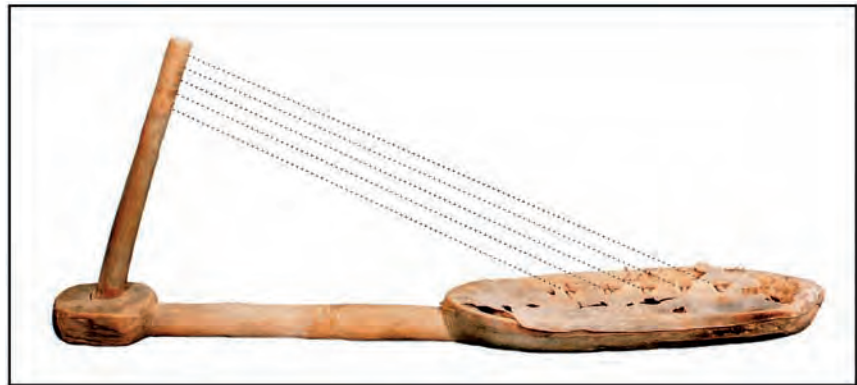

FIGURE 8 An extant steppe harp excavated near Shanshan, Xinjiang, China.

instruments without players,² and the instruments hover in the air decorated with ribbons. Figure 7 shows one side of this plaque on which there are two harps, one an arched harp, the other a phoenix variant of the vajra harp. A painting found at the Alchi site (dated 1000–1200) shows a harp with a sharply bent rod reminiscent of Chen Yang's phoenix-variant vajra harp (Goepper et al. 1996: 44).

Considering the wide geographic distribution of this variant of the vajra harp—between Japan and the Indus—and its close association with Buddhism, one would not be surprised to find it at Dunhuang. But it has not yet been reported there. Indeed, this instrument has only now been recognized as a separate type of harp with international spread.

Steppe Harps

A fourth category of instrument is the steppe harp, which I have so named because several well-known examples had been found buried at the edge of the vast Eurasian steppe zone. They belong to the wider category of horizontal angular harps that were first depicted in Mesopotamia around 1900 B.C.E. and continued on Assyrian monuments 850–650 B.C.E. Recently steppe harps were found in tombs excavated in the extreme western part of China, the Xinjiang Autonomous Region. The tombs date to the first millennium B.C.E., that is, before the Silk Road became active. About five harps have been recovered, some in excellent condition, as seen in figure 8 (Lawergren 2003: 89–91, fig. 11). Since their shape is reminiscent of the Assyrian harps, steppe harps appear to be the result of an eastward migration. Although not part of the “classical” Silk Road migration of the first millennium C.E., steppe harps nonetheless show that Xinjiang

lay open to Western musical influences centuries earlier. Of the different harp types discussed here, steppe harps are the only ones that do not seem to have spread east of Xinjiang.

Some of these harps were found in the dry sands at Zaghunluq cemetery in Qiemo county, Xinjiang. This remote site lies on the southern route of what would become the Silk Road around the Takla Makan (Wang Zichu 1999: 60). A similar harp was recently found at Yanghai in Shanshan county on the northern route.

These instruments are similar to three long-known extant harps. One was well preserved in a frozen tomb at Pazyryk in the Altai mountains in Siberian Russia; it is dated to 350 B.C.E. (Lawergren 1990). Another harp was poorly preserved in a tomb at Bashadar (near Pazyryk) with a similar date. The third, belonging to the Samartian culture, was found at Olbia on the Black Sea (Bachmann 1994). It dates to 75–100 C.E. (O. Simonenko, pers. com. 2005). Horizontal angular harps, some with nine strings (Lawergren and Gurney 1987: 51), were also depicted in royal Assyrian art around 900 to 600 B.C.E. (Rashid 1984: figs. 137, 146). It is known that some Eurasian peoples, for example, the Scythians (Lawergren 2003: 90), worked as mercenaries in the Assyrian army, and I surmise such equestrian people brought the harp to Xinjiang. The small size and light weight of these harps facilitated this migration. Steppe harps were not associated with Buddhism, and tombs with steppe harps contained no Buddhist paraphernalia.

Conclusion

Harps were among the many light instruments brought into China from the West by Silk Road travelers, many of whom passed through Dunhuang. Their instruments are shown on the walls of Dunhuang caves and grottoes, and the depictions provide an excellent source for musical study. But harps are also found in archaeological excavations in the nearby Xinjiang Autonomous Region and in depictions over a wider area, including Japan, Inner Mongolia, and northern India.

The Chinese term for harp, *konghou*, suggests that only a single kind of instrument existed, but so far four types have been recognized: angular, arched, vajra, and steppe harps. Although harps died out in China around 1000 C.E., the tradition is now being revived in several places. At present, replicas of vertical angular harps are owned and promoted by the National Theatre in Tokyo and by MBC Television in Jeonju (Korea).

Notes

- 1 However, an orchestra from Upper Burma was presented to the court at Chang'an in the year 802 (Picken 1984: 245). It included nineteen different types of instruments, including two phoenix-headed harps (*feng shou konghou*). Animal-head decorations were characteristic of arched harps (e.g., fig. 2).
- 2 In China these instruments are called *bu gu zi ming* ("no drum-beating, but sounding on its own").

References

- Bachmann, W. 1994. Die Skytisch-Sarmatische Harfe aus Olbia. Vorbericht zur rekonstruktion eines univerröfentlichten, im kriege verschollenen musikinstrumenten. In *Sons Originels: Préhistoire de la musique, Liège 11–12–13 décembre 1992*, ed. M. Otte, 111–34. Liège, Belgium: Université de Liège.
- Blunden, C., and M. Elvin. 1983. *Cultural Atlas of China*. New York: Facts on File.
- Chen Yang. 1979. *Yue shu*. Si ku quan shu zhen ben 9 ji, vols. 66–75. [Taipei]: Shang wu.
- Cowell, E. B., F. M. Müller, J. Takakusu, and Asvaghosa. 1969. *Buddhist Mahâyâna Texts*. Sacred Books of the East, vol. 49. New York: Dover Publications.
- Fong, W. C., J. C. Y. Watt, and Guo li gu gong bo wu yuan. 1996. *Possessing the Past: Treasures from the National Palace Museum, Taipei*. New York: Metropolitan Museum of Art.
- Frodsham, J. D., and Li Ho, eds. 1970. *The Poems of Li Ho (791–817)*. Oxford: Clarendon Press.
- Goepper, R., J. Poncar, K. Dasser, and R. N. Linrothe. 1996. *Alchi: Ladakh's Hidden Buddhist Sanctuary: The Sumtsek*. Boston: Shambhala.
- Lawergren, B. 1990. The ancient harp from Pazyryk. *Beiträge zur allgemeinen und vergleichenden Archäologie* 9–10: 111–18.
- . 1994a. Buddha as a musician: An illustration of a Jataka story. *Artibus Asiae* 54 (3–4): 226–40.
- . 1994b. Mesopotamien [archaeological]. In *Die Musik in Geschichte und Gegenwart: Allgemeine Enzyklopädie der Musik*, ed. L. Finscher, vol. 6, 143–71. Kassel: Bärenreiter.
- . 1995. The spread of harps between the Near and Far East during the first millennium A.D.: Evidence of Buddhist musical cultures on the Silk Road. *Silk Road Art and Archaeology: Journal of the Institute of Silk Road Studies, Kamakura* 4: 233–51.
- . 2001. Harp (ancient). In *The New Grove Dictionary of Music and Musicians*, 2nd ed., ed. S. Sadie and J. Tyrrell, vol. 10, 881–88, 894–96. London: Distributed by Macmillan.

- . 2003. Western influences on the early Chinese *Qin*-zither. *Bulletin of the Museum of Far Eastern Antiquities* 75: 79–109.
- . 2008. The instruments of *raigoo* images in Japan. In *Medieval Sacred Chant: From Japan to Portugal = Canto sacro medieval: Do Japão a Portuga: Actas do Colóquio Internacional Monodia sacra medieval, Lisboa-Évora, 2-5 de junho 2005*, ed. M. P. Ferreira and J. P. d'Alvarenga. Lisbon: CESEM, Colibri. www2.fcsh.unl.pt/cesem/actividades/MONODIAProg.pdf.
- Lawergren, B., and O. R. Gurney. 1987. Sound holes and geometrical figures: Clues to the terminology of ancient Mesopotamian harps. *Iraq* 49: 37–52, pls. X–XII.
- Louis-Frédéric. 1995. *Buddhism*. Flammarion Iconographic Guides. Paris: Flammarion.
- Picken, L. E. R. 1984. Instruments in an orchestra from Pyu (Upper Burma) in 802. *Musica Asiatica* 4, ed. L. E. R. Picken, 245–70.
- Piotrovsky, M. B. 1993. *Lost Empire of the Silk Road: Buddhist Art from Khara Khoto (X–XIII Century)*. Lugano and Milan: Thyssen-Bornemisza Foundation and Electa.
- Rashid, S. A. 1984. *Mesopotamien*. 1st ed. Leipzig: VEB Deutscher Verlag für Musik.
- ten Grotenhuis, E. 1999. *Japanese Mandalas: Representations of Sacred Geography*. Honolulu: University of Hawai'i Press.
- Wang Zichu. 1999. Reconstruction of Konghou (plucked stringed instrument). *Wen wu* 7: 50–60.
- Watson, B., and Kumarajiva. 1993. *The Lotus Sutra*. New York: Columbia University Press.
- Yao Shihong. 1983–85. [Musical instruments and dancing depicted as they appear in wall paintings at the Kizil Grottoes]. In *Kijiru sekkutsu = The Caves of Qizil, Xinjiang Weiwu'er Zizhiqu wen wu guan li wei yuan hui, Baicheng xian (China)*, vol. 2, 237–57. Chugoku Sekkutsu = Caves of China. Tokyo: Heibonsha.
- Zuber, S. M. 1940. Muzykal'nye Instrumenty v Ikonografii Khara-Khoto = Musical instruments in the iconography from Khara-Khoto. *Trudy Otdela Vostoka* 3.

Stein and Trinkler on the Rawak Vihara: A Mandala Style Moves East

Fred H. Martinson

Abstract: *Since 1995, as part of a series of presentations to the Southeast Conference of the Association of Asian Studies, I have been exploring several ideas about how Buddhist mandalas are expressed in Chinese art history. In researching this topic from 1999 to the present, I have become intrigued with one site that may be mentioned by Xuan Zang (traveled 629–45), Rawak, which is located just northeast of Khotan. Little seems to have been done on this site since Sir Aurel Stein’s treks there at the turn of the twentieth century; an exception is Emil Trinkler, a German, who traveled there in the late 1920s and published several books on his discoveries in the early 1930s. His writings give us rather conclusive dates for Rawak. The shape of its stupa illustrates my theme of mandalas, and I use some of the images in the best condition from the finds of Stein (91 statues published) and Trinkler (31 statues published) to examine how styles from Indian areas came early to the Takla Makan. Brief mention of one or two of the half dozen other stupas close to Khotan provides the context.*

The work presented here is about the Rawak Vihara, a Buddhist shrine located just northeast of Khotan (modern name, Hotan) that probably dates to some time between the third and fifth centuries C.E. This area was an ancient Buddhist kingdom on the branch of the Silk Road that ran along the southern edge of the Takla Makan Desert in western China’s Xinjiang Uyghur Autonomous Region. The central feature of the shrine was a tall domed stupa, which is a reliquary representing the passing, or nirvana, of the Buddha; it was used for circumambulation—or movement around the symbolic remains of the Buddha—in religious rituals. The stupa sat in the center of a square courtyard that was bordered by inner and outer walls that may have been

roofed and served as a monk’s quarters. *Rawak* means “high mansion” in Uyghur, and *vihara* is an Indian Sanskrit term meaning “the dwelling places of monks.”

Rawak can only be understood from the writings of two Western explorers: the Hungarian-British archaeologist Sir Marc Aurel Stein (1862–1943), who made two expeditions there at the turn of the twentieth century (Stein 2001: 304), and the German geologist Emil Trinkler (1896–1931), who explored the area during his central Asian expedition of 1927–28 (Gropp 1974). Trinkler’s expedition appears to have been the last one to work at Rawak, which today is nearly forgotten. The photographs and documentation produced by these two explorers are all that remain of Rawak. The sands of the Takla Makan Desert have reclaimed nearly everything. Reaching Rawak is arduous, even today. One modern guidebook to the region states: “The buried cities of the Khotan region explored by (Sven) Hedin and Stein are as inaccessible as ever. . . . Rawak is about 90 kilometers (56 miles) from Khotan. There are no roads into the desert, necessitating well-planned camel expeditions” (Bonavia 1990: 317).

Around 1996 Richard Bernstein of the *New York Times* and *Time* magazine retraced the steps of Xuan Zang, a famous Chinese Buddhist monk who had visited Rawak during his journey from China to India and back between 629 and 645. Bernstein writes:

A jeep took us north into the desert, which was a maze of under-construction irrigation canals. When we could go no farther in the jeep, we hiked about two miles through sand dunes to the stupa. It wasn’t much—a mud pedestal of baked brick atop a broader circular mound in which you could still see the

indentations of former doorways. All of it was within a square arena surrounded by a squat retaining wall, while all around the dunes undulated under the wind. The style is Gandharan. (2001: 313–14)

In the 1990s NHK (the Japan Broadcasting Corporation) produced a twelve-part program titled *The Silk Road* (Tamai, Webster, and Kitara 1990). The aerial photography for the Khotan segment shows that the Rawak Vihara is indeed filled with sand to the tops of the walls that Stein and Trinkler found, but it is interesting that both the outline of the walls and the top of the stupa are still clearly visible.

Layout of the Rawak Vihara

Figure 1 shows the layout of the Rawak Vihara. This is a composite plan I based on drawings made by Stein and Trinkler. The numbering refers to the location of sculptures identified by Stein (R grouping) and by Trinkler (D grouping).

The stupa itself is built on a 78-foot-square (24 m²) base and is about 31 feet (9.5 m) high. Extending out from the stupa are arms of stairs. The arms are bisymmetrical and in the form of a *visva-vajra*—a crossed vajra, which is a ritual device with prongs on each end. The vajra represents a diamond or thunderbolt, both of which are equated with the immutability of Buddhist doctrine. The stairways extend outward from the center of the stupa about 39 feet (12 m), and the stairs are 14 feet (4.3 m) wide.

The two sets of walls that surrounded the courtyard were penetrated on each side by gateways. The inner and more complete set of walls measured 109 feet by 130 feet (33.5 by 40 m). Only a small corner of the outer wall existed at the time of Stein's and Trinkler's visits (see fig. 1, bottom left). The outer walls would have formed a corridor about 9 feet (2.7 m) wide with the inner walls, and thus the outer walls would have measured 127 feet by 148 feet (39 m by 45.5 m). In the layout of Rawak the inner and outer walls are set back from the stupa on each side of the courtyard, creating the same design that is used in two-dimensional mandalas.

FIGURE 1 Composite plan of the Rawak Vihara based on Stein and Trinkler. Numbers indicate sculpture locations identified by Stein (R grouping) and Trinkler (D grouping). © Fred H. Martinson

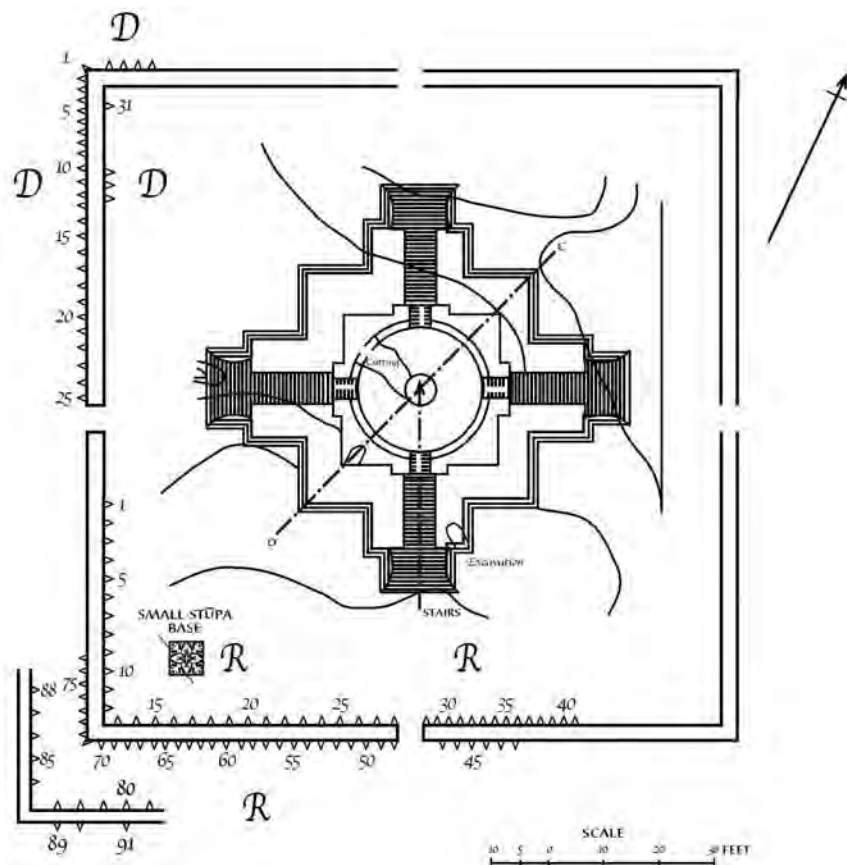

Merriam-Webster's Collegiate Encyclopedia (2000: 1006) defines *mandala* as “a diagram representing the universe, used in sacred rites and as an instrument of meditation.” A mandala may be painted on paper or cloth, drawn on the ground, or made of bronze or stone. Mandalas often emphasize the four directions; they are placed in the center of a square or circle with statues of buddhas and other deities placed appropriately at a given direction. Mandalas may also be sculptural groups, layouts of cities, or even features in a landscape used in a religious context. In other words, some of these sacred representations may be large enough for a devotee to literally participate inside and be a part of the mandala.

Statuary at Rawak

Stein and Trinkler found large statues, usually life-size and sometimes twice life-size, inside and outside both sets of walls at Rawak. Most of the statues are of the Buddha, but some are of bodhisattvas, or “enlightenment beings” who postpone their buddhahood to save all sentient beings on earth. A few of the statues have identifiable iconographies (religious meaning), discussed below, but most cannot be specifically labeled. For this reason it is not possible to suggest an overall iconographic program for the site.

Figure 2 shows the best examples of what much of the sculpture looked like when Stein visited the Rawak Vihara (Stein 2001: fig. 66).¹ These statues are found along the exterior south corner of the inner wall and are numbered R66–74 on the Rawak map (see fig. 1). If this amount of sculpture was present on both interior and exterior sides of the inner wall surrounding the stupa and if there was an equally decorated outer wall all the way around, this must have been a most impressive monument. Based on the ninety-one sculptures Stein found and the additional thirty-nine that Trinkler found, we can estimate that five hundred or more statues at one time adorned the Rawak Vihara, probably in a definite Buddhist program or iconography.

Gandharan Style

The plan of the Rawak Vihara conforms to the bisymmetrical type seen in many structures at the Buddhist university at the Taxila archaeological site in the area of Gandhara in Kashmir (politically today, Pakistan). Such a plan would have been the origin of the mandala concept for Rawak and for many points east. Most of the buildings at Taxila are



FIGURE 2 Ruins of colossal statues along the exterior south corner of the inner wall of the Rawak Vihara (remains of outer wall in foreground). Photograph from the Stein Library, Library of the Hungarian Academy of Sciences, Budapest

dated to between the third and fifth centuries C.E. Indeed, the rulers of the Khotan area in China came from Gandhara. For an architectural comparison with the Rawak stupa and even its type of source, see the stupa of Bhamala Monastery at Taxila, which is dated to the fourth or fifth century C.E.²

Gandhara often brings to mind the area of the much earlier Greek kingdoms established by Alexander the Great in his easternmost advance into Asia between 337 and 325 B.C.E. Because of his conquests, there is a kind of Greco-Roman art style in sculpture and in the few surviving paintings that was mixed with local, Indian styles, especially with Buddhist subject matter. That style is called “Gandharan” after the region. It is this style, showing Greco-Roman influences on the art of the southern Silk Road, that was dominant, including at the site of Rawak.

Dating Rawak

A remaining question is, can we date the construction of Rawak? Trinkler dates the Rawak Vihara in this passage from his writings:

Rivers often submerged the southern border of the sea of sand during extraordinary floods. This is proved by extensive clay deposits that can often be traced deep into the heart of the desert. A section near the famous Rawak stupa showed me that such an inundation had

taken place here after the third–fifth centuries A.D., because the corresponding culture deposits of pottery debris, Chinese coins, bones, and beads are buried below the clay layer. These layers were deposited during an inundation by the Yurungqash Darya [now called the Khotan Darya, the river that flows through the town of Khotan]. The old dry bed of this river can still be seen some 4 miles to the east of the ruin. After that high flood the river changed its bed, shifting it some 12 to 14 miles to the west. (1930: 512–13)

What is important about this statement is that Trinkler has dated Rawak to a time between the third and fifth centuries C.E. These are precisely the dates for many of the buildings at Taxila mentioned above. Thus the building of Rawak is nearly contemporary with its Gandhara sources, suggesting a mandala style moving to the east.

Xuan Zang: An Early Traveler to Khotan

Xuan Zang, an eminent and learned Buddhist monk, as well as religious adviser to the emperor, left China in 629 C.E. for India to acquire original Buddhist sutras (scriptures) and a more comprehensive knowledge of Buddhism’s tenets and practices. He was gone for sixteen years, returning to the Chinese capital at Chang’an (the present city of Xi’an) in 645. Since he returned to China on the southern Silk Road, he visited the Khotan area and possibly Rawak late in his journey. When he returned home, he wrote an account of his adventures titled *Xiyouji*, or *Journey to the West* (Xuan Zang and Beal 1969).³

Xuan Zang seems to have traveled north and east from Khotan to the area of the early temples: Vaisravana Temple (p. 311), Vairochana Temple (p. 312). My investigations turned up new information about Rawak in Xuan Zang’s writings.

Near the end of his book, Xuan Zang has a chapter on Khotan.⁴ In it, he discusses a legend of the exile of a tribe from Taxila in Gandhara to Khotan by the great Indian king Ashoka (ca. 269–232 B.C.E.). This tribe traced its ancestors to the deity Vaishravana, Guardian of the North. The first king was a Buddhist who raised a Vaishravana temple and statue to his ancestors. The king was Buddhist and a patron of Buddhist art.

Xuan Zang states that east of the capital Khotan are the ruins of a town called Pima—Pi-mo, probably near Yutian (Keriya)—where there was a 20-foot-high (3 m) statue of a standing Buddha in sandalwood (Xuan Zang and Beal 1969:

324 n. 72). A look at the map of Khotan inside the back cover of Stein’s book (2001) shows that the Rawak Vihara is indeed located both east and north of Khotan. Furthermore, the Buddha statue may be related to a legend, recounted by Xuan Zang, that when the Buddha reached nirvana, the statue on its own flew to the north to “Ho-lo-lo-kiā” (*Heluoluojia* in modern Chinese transliteration), which is identified as “Raga” or “Raghan” or “Ourgha” by Samuel Beal in a footnote to his translation of the *Journey to the West* (Xuan Zang and Beal 1969: 322–23 n. 69).

“Rawak” was a term used by the Uyghur *turdi* (local treasure hunters) when Stein visited (Xuan Zang and Beal 1969: 304). Even the conventional use of sounds might make it a Turkish (Uyghur is a Turkish language) version of Xuan Zang’s Raga or Raghan. I propose, then, that the Pima ruins with the sandalwood Buddha that Xuan Zang describes are those of the Rawak Vihara. If this is true, Rawak is a central Asian site given by Xuan Zang that we can identify today. However, only two centuries after Rawak was built, Xuan Zang encountered a sand-buried monument. The sands of the Takla Makan had already reclaimed both Rawak and Khotan.

Rawak Sculpture Discovered by Stein and Trinkler

As noted above, the ground plan of Rawak is in the shape of a mandala. All the sculptures at the site were placed on the walls around the stupa, thus giving them a place in the mandala. A few selected photographs of these sculptures are described below, with notes giving the photographic source information.

Stein’s Discoveries

In figure 1 Stein’s sculpture discoveries are the numbers in the R grouping found on the southwestern and south walls at Rawak. Each sculpture described below is identified with its R number so that it can be located on the figure.

Colossal Buddha with Abhaya-mudra (R1). This statue (fig. 3) gives the best general idea of the scale and type of sculpture that Stein encountered (see Stein 2001: fig. 69). The buddha with Abhaya-mudra, a hand gesture meaning no fear (although the arm is missing), is the tall, headless sculpture to the extreme right in the photograph, behind one of Stein’s workers (second person from the right). Since this sculpture measures 5 feet 3 inches (1.6 m) from its feet to just below the bent elbow (arm missing), it is clear that this buddha was



FIGURE 3 A headless buddha with Abhaya-mudra (right) and a life-size bodhisattva (left) at the Rawak Vihara. Photograph from the Stein Library, Library of the Hungarian Academy of Sciences, Budapest

over 3 meters high. The abundant, congruent folds of clothing are in a Greco-Roman manner known as Gandharan style, as described earlier.

Bodhisattva (R4). To the extreme left in figure 3 is a life-size bodhisattva that Stein (2001: 419) describes as being about 6 feet (1.8 m) high. The figure is dressed differently than the previous statue; he wears the garments of a prince (and note the jewelry on his chest). A bodhisattva is a savior being, a potential buddha, just as was the historical Buddha (Siddhartha Gautama, ca. 563–483 B.C.E.) before his enlightenment. The head fell off the statue after this photograph was taken and can be seen on the ground in another of Stein's photographs (2001: fig. 61; not included here). Stein brought back the head of this statue for the British Museum and published a black-and-white photograph of it in his book *Ancient Khotan* (2001: pl. 81).

Seated Buddha (R11). The seated buddha, lower left in figure 4, is in yoga asana, that is, seated in the pose of a meditating yogi (see Stein 2001: figs. 62, 62). This is unusual among the Rawak statues, as most are standing figures. Note the *dhyana-mudra* (hand position of meditation) that is associated with Amitabha, the buddha of the

west. Such directional buddhas would literally have their appropriate place in the mandala-stupa, on the west side in this case. The surviving whitewash over an entirely smooth body is a primer that suggests this was a colorfully painted statue, as supported by the paint flecks found by Stein and Trinkler.

Additional Sculptures. Some of the most extraordinary and complex statues must have been the two colossal buddhas (R12 and R13) located at the south corner of the inner wall around the Rawak stupa (Stein 2001: figs. 63, 64). Unfortunately, these statues have survived only from about the knees down. Behind each statue is what Stein calls a "vesica," meaning a *vesica piscis* (an Italian term meaning an aureole, nimbus, or mandorla), and within each vesica there are many smaller, mold-made buddha figures (up to about 36 cm long). The aureoles behind these buddhas are 2.3 meters across. The aureole of R12 is visible in figure 4, behind the seated buddha (R11) described above.

Trinkler's Discoveries

Trinkler's expedition furnished us with additional images of the sculpture at Rawak. In figure 1, Trinkler's discoveries are the D group of numbers along the northwestern and western walls. In general, his photographs are closer up than Stein's



FIGURE 4 Seated buddha, lower left, at the south corner of the inner wall of the Rawak Vihara. Visible behind this statue and slightly to the left is the aureole (of a partial buddha) containing small buddha figures. Photograph from the Stein Library, Library of the Hungarian Academy of Sciences, Budapest



FIGURE 5 Head of the Vairocana with Wavy Hair from the Rawak Vihara. Metropolitan Museum of Art, Rogers Fund, 1930 (30.32.1)



FIGURE 6 Head of the Vairocana with Brow Depression from the Rawak Vihara. Metropolitan Museum of Art, Rogers Fund, 1930 (30.32.3)

and provide more detail. The photographs also convey more iconographic detail.

Buddha statues photographed by Trinkler with specific iconography include the Vairocana with Wavy Hair (D17)⁵ and a similar statue, the Vairocana with Brow Depression (D19).⁶ Vairocana is often called the cosmic buddha and is found in the center of many mandalas surrounded by four buddhas representing the four directions. The heads of these two statues, shown in figures 5 and 6, respectively, are in the Metropolitan Museum of Art and are thus missing the distinctive *dharmachakra-mudra* (turning of the wheel of the law) of the smaller buddha figures in the elaborate aureoles that were behind the statues at Rawak.

Conclusion

The Rawak Vihara was an ambitious and probably expensive enterprise. It contains the largest stupa complex on the

southern Silk Road, and, unlike other sites, it had many life-size and twice-life-size statues as well as some paintings. The statues and probably architectural parts of the Rawak Vihara were painted, and the entire complex was likely part of a human-scale sculptural mandala.

The iconography of the statues and the architectural context for them are difficult if not impossible to discuss, because we do not have a comprehensive view of the entire complex. It can be imagined that the stupa probably followed a mandala plan, with a Vairocana buddha (the cosmic buddha) at its center surrounded by the buddhas representing the four directions.

The beauty of the Rawak Vihara is unsurpassed elsewhere in Xinjiang, and the *visva-vajra* plan probably comes directly from Taxila in Gandhara, as does the style of rich, swirling drapery on some of the statues. The original monument with plaster, whitewash, and color must have been stunning. I do think (or would like to think) that Xuan Zang saw it.

Notes

For consistency, we use place-name spellings as they appear in the *National Geographic Atlas of the World*; e.g., Khotan is referenced in parentheses as Hotan. *Khotan* is the Turkish; *Hotan* is the old Chinese spelling and would be referred to on a PRC map as *Hetian*.—ED.

- 1 Statue numbers are R66–R74.
- 2 See Ahmad Hasan Dani, *The Historic City of Taxila* (Paris: UNESCO, 1986), 196; and Sir John Marshall, *A Guide to Taxila* (Karachi: Sani Communications, 1960), fig. 14.
- 3 The best modern book on Xuan Zang in English is Sally Hovey Wriggins, *The Silk Road Journey with Xuanzang*, rev. and updated (Boulder, CO: Westview Press, 2004).
- 4 The Chinese that Xuan Zang uses for this site is *K'iu-sa-ta-na* (*Qiusadana*, in modern Chinese). This term is a transliteration of the Khotanese name *Kustana* and is the Chinese name for the site used in the title on the Rawak map (fig. 1) below the English *Khotan*.
- 5 Gropp 1974: pls. 100, 101; now in the Metropolitan Museum, New York, accession no. 30.32.1.
- 6 *Ibid.*, pls. 100, 103; now in the Metropolitan Museum, New York, accession no. 30.32.3.

References

- Bernstein, R. 2001. *Ultimate Journey: Retracing the Path of an Ancient Buddhist Monk Who Crossed Asia in Search of Enlightenment*. New York: Knopf.
- Bonavia, J. 1990. *The Silk Road: Retracing the Ancient Trade Route*. Lincolnwood, IL: Passport Books.
- Gropp, G. 1974. *Archäologische Funde aus Khotan Chinesisch-Ostturkestan: Die Trinkler-Sammlung im Übersee Museum Bremen*. Monographien der Wittheit zu Bremen, no. 11. Bremen: Röver.
- Stein, M. A. 2001. *Ancient Khotan: Detailed Report of Archaeological Explorations in Chinese Turkestan*. Bangkok: SDI Publications.
- Tamai, I., G. Webster, and Kitano. 1990. Khotan: Oasis of silk and jade. *The Silk Road*, episode 7. DVD. Central Park Media, New York.
- Trinkler, E. 1930. Explorations in the Eastern Karakoram and in the Western Kunlun: A paper read at the evening meeting of the Royal Geographic Society on March 24, 1930. *Journal of the Royal Geographic Society* 75 (6): 505–15.
- Xuan Zang and S. Beal. 1969. *Si-yu-ki: Buddhist Records of the Western World*. Delhi: Oriental Books Reprint Corp.

PART FOUR

Planning and Management

Conservation and Management of Cultural Heritage Sites on the Silk Road in Kyrgyzstan

Ludmila Akmatova and Jumamedel Imankulov

Abstract: *On the central Asian portion of the Silk Road, a number of historic and cultural monuments have attracted interest from people throughout the world. Kyrgyzstan (the Kyrgyz Republic) has not received much of this attention, however. This paper addresses the current situation in Kyrgyzstan regarding the state of preservation and restoration of these sites, many of which are located in the north in the Chui River valley and the Lake Issyk-Kul basin. Because of the increasing number of tourists to these sites, several measures have been taken by the government to preserve them. Researchers have studied a number of sites throughout Kyrgyzstan. Some of these are already open to the public, and state agencies are in place that formally control tourist flow. In addition, private tourism companies have been established.*

Despite these accomplishments, unresolved problems remain. Heritage sites are under exclusive state ownership and lack defined buffer zones and legal registration. Also, there is a lack of coordination among government bodies concerned with the preservation of heritage sites. A number of archaeological sites that are potentially attractive to visitors and have undergone extensive research have not received state financing or undergone exploratory surveys.

With regard to tourism, the major problem is the lack of adequately trained personnel and the absence of policies governing tourist flow. In addition, Kyrgyzstan does not currently have an educational institution that can provide specialized training in the protection of cultural heritage sites. Importantly, the lack of trained personnel extends to specialists in preservation and restoration and, to a lesser degree, researchers.

On the central Asian portion of the Silk Road, a number of historic and cultural monuments have attracted interest from people throughout the world. Although Kyrgyzstan (the Kyrgyz Republic) has not received much of this attention, it possesses important cultural heritage sites that are now gradually becoming better known internationally. This paper addresses the current situation in Kyrgyzstan regarding the state of preservation and restoration of its cultural heritage sites along the Silk Road.

The Silk Road in Kyrgyzstan

Starting in the second century C.E.,¹ transcontinental trade routes crossed the Tian Shan and Pamir Mountain ranges of southern Kyrgyzstan (Bernstam 1952), connecting the countries of the Mediterranean Sea with the Yellow and Yangtze River basins in China (fig. 1). The principal Silk Road routes passed through the Chui (or Chuy) River valley of northern Kyrgyzstan into the Lake Issyk-Kul basin,² then via the Bedel pass into Xinjiang in China. Another route led from the Lake Issyk-Kul basin, through the Kegen (Santash) pass, and into Siberia and Mongolia. This route was traversed between 629 and 645 C.E. by Xuan Zang,³ in part by John of Plan Carpin between 1245 and 1247,⁴ and by William of Rubruck between 1252 and 1256.⁵

These extensions of the Silk Road not only connected countries and peoples commercially; they also became a bridge between the cultures of many different civilizations. As such, they contributed to the intensive development of Kyrgyzstan's territory, culture, and economy and strengthened international relations. The influence of different civilizations on the cultural heritage of Kyrgyzstan is vividly

FIGURE 1 Principal Silk Road routes through Kyrgyzstan.

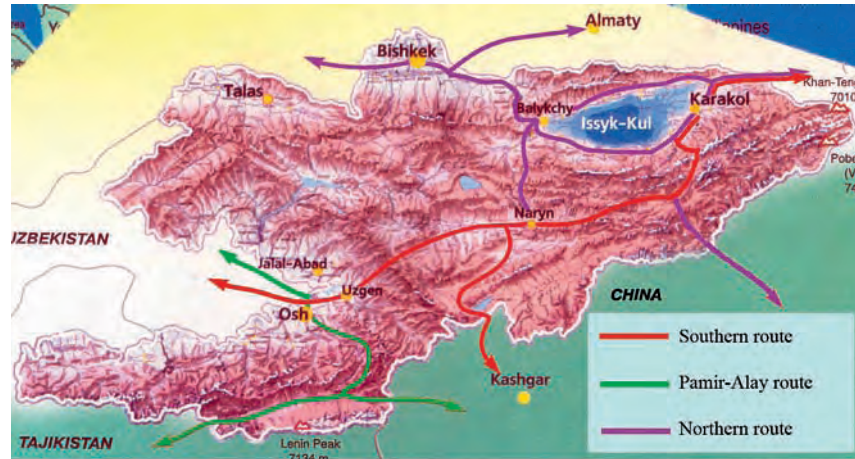

represented in the ancient monuments associated with the Silk Road, most of which are concentrated in the Lake Issyk-Kul basin in the northeast and in the Chui River valley in the north.

Lake Issyk-Kul Basin

The Lake Issyk-Kul basin is a unique combination of historical, cultural, and natural features (fig. 2). Among its archaeological attractions are petroglyphs, earthen rampart walls from medieval settlements, large barrows made by early nomads, epigraphic memorials, and ancient canals

(Vinnik 1974). The basin’s cultural heritage was influenced by the natural environment, as well as the primary needs of the ancient inhabitants and their responses to interlinking social, economic, administrative, and religious conditions. The Lake Issyk-Kul basin, which was nominated to the UNESCO World Heritage List in 2004, is a single geocultural region with distinctive cultural elements and, as such, falls within the UNESCO category of a cultural landscape. The physical boundaries of this cultural landscape are defined by the shoreline of Lake Issyk-Kul and by the Terskey Ala-Too Mountain range to the south and the Kungey Ala-Too range to the north.

FIGURE 2 Historical and cultural sites of the Issyk-Kul basin. Courtesy Scientific Research Institute “Kyrgyzrestoration”



Responsible for the project: Science and research project office “Kyrgyzrestoration”
Ministry of culture and education Kyrgyz Republic

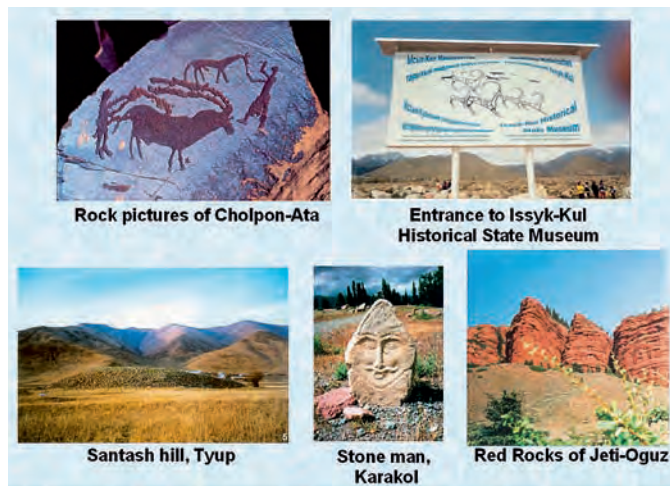

FIGURE 3 Important cultural and natural sites in the Issyk-Kul basin.

Figure 3 shows some of the many remarkable sites in the Lake Issyk-Kul basin. Sites include Jeti-Oguz, a picturesque canyon around the town of Karakol; Tamga-Tash, a rock carved with ancient Tibetan Buddhist inscriptions at the Tamga River gorge; Toru-Aighyr, a small village east of Balykchy, near where eleventh- to twelfth-century baths were discovered; Ak-Chunkur, a prehistoric cave near the Sary-Jazz River; and Cholpon-Ata, a resort center with petroglyphs of animals and hunting scenes dating from 500 B.C.E. to 100 C.E. Many of these sites have been strongly influenced by religious, artistic, and cultural associations with the natural world and therefore fall within the UNESCO category of associative cultural landscape.

The Issyk-Kul cultural landscape formed from the interaction between humans and nature over many millennia. Examples of this interaction are the barrows left by early cultures (e.g., Sak and Usun), the large stones bearing petroglyphs found among human settlements and on foothill terraces, and the ruins of ancient settlements in the form of earthen mounds. Scientific research has confirmed the authenticity of these archaeological sites, whose integrity has been preserved in the contemporary landscape and which are viewed by the Kyrgyz people as an integral part of their habitat. Most of the region's cultural sites still serve as sanctuaries and places of worship (*mazars*) for pilgrims, not only from the Lake Issyk-Kul basin but from other regions of Kyrgyzstan as well.

In 2002, by resolution of the Issyk-Kul State Administration, the Museum Association was established within the

Issyk-Kul State Historical-Cultural Museum-Reserve, which consists of 100 hectares (1 km²) set aside to house a museum and to protect outdoor immovable cultural heritage (e.g., the petroglyphs of Cholpon-Ata, Kara-Oi, Sary-Oi, and Chon-Sary-Oi, as well as the Karool-Debe ancient settlements). The Museum Association supervises both the museum collections and the immovable cultural heritage.

Existing data on the Lake Issyk-Kul basin identify it as one of the world's unique natural and cultural regions. Studies also reveal the alarming fact that the region's cultural sites are in danger of disappearing, despite their significance. Urgent measures are needed to safeguard them and to enhance public awareness of both their importance and their vulnerability.

Chui River Valley

The Chui River valley is the most advanced region in Kyrgyzstan and includes the country's capital, Bishkek. During the early Middle Ages, the area was a major trade, economic, and ethnocultural crossroads of Eurasia.

Archaeological excavations conducted in the Chui River valley between 1940 and 2000 identified cities and monumental architectural constructions dating from the fifth through seventh centuries C.E. (Kyzlasov 1959; Ziablin 1961). Researchers were able to trace cultural and artistic influences from Byzantium to the west, Iran to the south, and China to the east that were left by the peoples who had inhabited the territory. The culture and art of the Chui River valley's Semirechie (Seven Rivers) region from this period are most vividly in evidence at the ancient settlements of Krasnaya Rechka, Ak-Beshim, and Burana, known in antiquity as Navikat, Suyab, and Balasagun, respectively. These ancient settlements, as well as Bishkek, are situated on a branch of the ancient Silk Road that led to Lake Issyk-Kul and then to China.

Krasnaya Rechka, Ak-Beshim, and Burana became unique centers of symbiosis where various cultures came together. The settlements maintained a link with these civilizations by means of the Silk Road, through which passed Buddhist pilgrims and Syrian monks, Sogdian merchants, Turkic tribal leaders, and ambassadors from Byzantium, Iran, India, China, and Xinjiang.

Of special interest at the ancient settlements of Krasnaya Rechka, Ak-Beshim, and Burana—referred to as the Golden Triangle—are examples of early medieval temple architecture reflecting Buddhism, Zoroastrianism, Christianity, and Islam. These monuments are among the finest achievements

of art and material culture to be found in the East, and perhaps in the world.

Preservation Activities

At Krasnaya Rechka (Navikat), the remains of the second Buddhist temple are of particular archaeological interest (fig. 4).⁶ The conservation and preparation for visitors of this monument, currently under way, will transform it into one of the most important sites not only at this ancient town, but in the Chui River valley as a whole. This work will involve advances in the field of physical and chemical preservation of earthen structures. Ideally, the most important exhibit of this temple would be the reinstallation of an 8-meter-tall sculpture of the Deceased Buddha. The sculpture now resides in the State Hermitage Museum in St. Petersburg, Russia, and would need to be returned to Kyrgyzstan in order to complete the temple. The safe display of this unique sculpture requires erecting a special shelter over the temple that is in harmony with the surrounding landscape. Additional historical, artistic, and technical investigations of this temple are prerequisites for its preservation.

The ancient settlement at Burana is popular among foreign tourists as well as the Kyrgyzstan people and is dominated by the oldest minaret found in central Asia and the ruins of mausoleums dating from the tenth to the twelfth century. The Burana minaret has become a symbol for the ancient Chui River valley, attracting increasing numbers of history lovers. The site is an open-air state museum of

architecture and archaeology, known as a museum-reserve, and its valuable collections make Burana the center of the historical cities constituting the Golden Triangle.

At Ak-Beshim, the important conservation need is presentation and interpretation for visitors of a room in a Christian cult center in what was the ancient settlement of Suyab (fig. 5). The construction of a shelter made of modern materials for protection against atmospheric influences has been proposed. Through this shelter, tourists would be able to view the unique arch. The conservation needs of the Suyab complex at Ak-Beshim are the most urgent, due to both the extremely rainy spring seasons of recent years and unsupervised visits to the monuments by tourists and local inhabitants. The absence of a secure buffer zone is a serious threat to the safety of these archaeological sites.

The proximity of Bishkek, the capital of Kyrgyzstan, to the unique natural and cultural landscape of the Chui River valley makes it possible to turn the ancient settlements at Krasnaya Rechka, Ak-Beshim, and Burana into a center that highlights the area's historical and cultural resources for international tourists. To realize the conservation and tourist use of the monuments at these ancient settlements, it will be necessary to create an international team of experts to develop concepts, programs, and projects. With the financial support of the Japan Trust Fund and UNESCO, preservation of archaeological sites in the Chui River valley is proceeding. The project, known as Preservation of Silk Road Sites in the Upper Chui Valley in Kyrgyzstan: Navikat (Krasnaya



FIGURE 4 Remains of an eighth- to ninth-century Buddhist temple at the ancient site of Navikat in the Chui River valley.

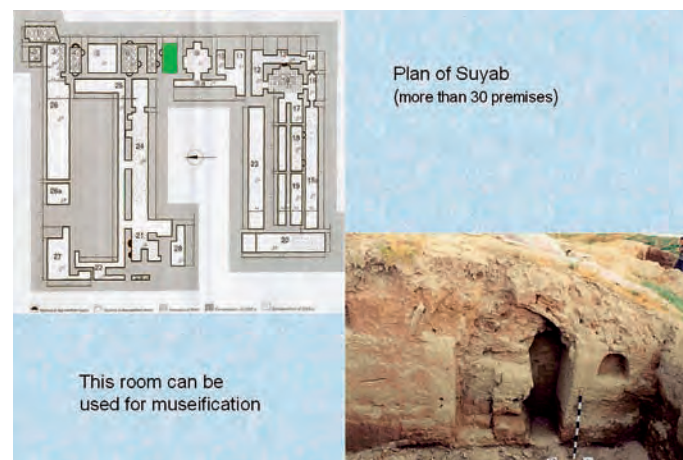

FIGURE 5 Plan of a Christian cult center in the ancient settlement of Suyab in the Chui River valley. Green rectangle indicates room being readied for tourism.

Rechka), Suyab (Ak-Beshim) and Balasagyn (Burana), is allowing Kyrgyzstan to generate a local cultural tourism revolution, which, it is hoped, will revive awareness of the significance of the traditions of the Silk Road.

Protecting Kyrgyzstan's Cultural Heritage

Tourism and Preservation

The rich historical and cultural heritage and traditions of the Silk Road in combination with a unique natural environment make Kyrgyzstan an ideal place for tourism. Because of the potential economic benefits, the Kyrgyz Republic is developing a number of initiatives to expand tourism, especially international tourism, primarily in the Lake Issyk-Kul basin and the Chui River valley. These sites already have been attracting increasing numbers of tourists, and the volume is expected to grow appreciably as the area becomes more widely known in the tourist market, emphasizing the need to undertake preservation measures.

Today's visitors to archaeological sites want to experience culturally important structures and artifacts in as real a context as possible. Visitors want to experience the elements and forms of construction in ways that will permit them to imagine the former characteristics of a monument that is now a ruin. Informed preservation and effective interpretation have become basic principles in the management of architectural and archaeological monuments. What is required is not simply conservation, but conservation framed by appropriate aesthetic judgment so that sites are exhibited most effectively.

To meet the needs of the country's tourism industry, policies concerning the preservation and use of cultural property are being addressed at the national (state) level. In 1999 the Kyrgyz Republic passed the law On Protection and Use of Historical and Cultural Heritage, which describes the basic objectives and tasks of preserving cultural property in the country and the legislative norms and conditions on the protection and use of historical and cultural monuments. In 2002 the republic approved regulation of registration, research, restoration, and use of historical and cultural heritage properties. In 2003 the president of the republic issued an order strengthening sanctions against illegal archaeological work and research and accepting measures that strictly implement the 1999 law.

As described earlier, two projects aimed at protecting Kyrgyzstan's historical, cultural, and natural heritage are under way: nomination of the Lake Issyk-Kul basin to the



FIGURE 6 Cultural heritage sites open to tourism in Kyrgyzstan.

UNESCO World Heritage List as a cultural landscape and the Japan/UNESCO-funded work to preserve the Silk Road sites in the Chui River valley.

Work on these two projects has identified the potential of these areas to create a national tourism industry, as well as the problems associated with their protection, preservation, and use. Over the past six years, a number of programs have been conducted to promote the Lake Issyk-Kul basin for tourist and recreational use. For example, the International Tourist Fair, an initiative of the government of Kyrgyzstan, is held annually at Cholpon-Ata. In addition, health-promotion organizations, travel companies, and relevant governmental bodies issue maps, brochures, booklets, and postcards featuring the area's most interesting sites.

The State Agency for Tourism, Sport, and Youth Policy along with local administrations organize annual meetings on the development of tourism and recreation and the protection and use of the region's historical-cultural and natural sites. International music festivals, including several weeks of activities aimed at children's musical creativity, are held in the recreational areas of the Issyk-Kul basin, and they have become a popular tradition.

Researchers have studied a number of monuments throughout Kyrgyzstan that are already being visited by tourists (fig. 6). In addition to the Lake Issyk-Kul basin and Chui River valley in northern Kyrgyzstan, cultural heritage areas of interest to the tourism industry are found in southern Kyrgyzstan, among them a twelfth-century architectural

complex in the Silk Road town of Ozgon (Uzgen) and the monuments around the sacred mountain known as Suleyman-Too in Osh, which has been nominated to the UNESCO World Heritage Tentative List.

Tourism Development Program

A number of governmental measures have been initiated to coordinate public- and private-sector activities in the development of tourism, to attract investment, to improve tour product quality, and to enable successful promotion in the international and domestic tourism markets. In 1999 the Kyrgyz Republic passed a law on tourism to address the needs of the industry. Subsequently, a ten-year program of development of the Tourism Branch in the Kyrgyz Republic was authorized (Government Resolution no. 33, 2001). This important document on tourism development determines the tasks on which the success of the industry depends. It also creates an opportunity to increase foreign investment, to create employment, and to retain and preserve unique archaeological finds and monuments of natural and cultural heritage. The program's principal elements are

- involving local administrations in tourism and promoting tourism; and
- cooperating with neighboring countries in tourism development on the Silk Road and in the development of visa regulations facilitating tourist travel among the countries concerned.

The Kyrgyzstan tourism development program is being implemented in three stages:

- Stage I, 2000–2002: During this stage, the Ministry of Education and Culture together with the Kyrgyz Republic National Academy of Science developed standards regarding the status of historical and cultural zones of the Silk Road and the preservation of unique archaeological monuments of cultural heritage. Research, restoration, and conservation work, together with enhanced security arrangements, at certain historical and cultural monuments has already begun. The State Committee for Tourism and Sport, working with travel agencies, has developed additional historical and cultural tourism routes. Itinerary sites include the Suleyman-Too historic-cultural and natural museum-reserve;

Ozgon (Uzgen); Shakh-Fazil; Manas Ordo; the Burana historical and cultural complex; the Tash-Rabat caravansaray; and the Cholpon-Ata museum-reserve.

- Stage II, 2002–5: During this stage, programs were developed for specialized kinds of tourism (historic-archaeological, cultural-ethnographic, religious, ecological, etc.), and access roads to the country's principal tourist sites were constructed or reconstructed.
- Stage III, 2005–10: This stage envisions the completion of arrangements to create a tourism corridor among the countries located on the Silk Road. This is an extremely serious endeavor and is being studied in all central Asian republics of the Commonwealth of Independent States (CIS) through their Ministries of Foreign Affairs. We hope for a positive outcome such that all countries in the CIS will have a single Silk Road visa.

Administration and Management of Cultural Heritage Sites

The following official bodies in Kyrgyzstan are responsible for the administration and management of cultural heritage sites:

- State Commission under the government of the Kyrgyz Republic on the Development of Culture and State Language. The commission's functions include registration, identification, research, protection, restoration, and use of historical and cultural heritage sites. It is responsible for state museums, historical and cultural museum-reserves, and historical sites of national (state) significance.
- Regional boards of culture. Seven provincial administrative units have functions similar to those of the State Commission but are responsible for museums and sites of regional significance.
- District inspectors' offices. These administrative offices have functions similar to the above but operate on the district level.
- Rural administration. At this level, officials have responsibilities that include those of inspectors but within the limits of the territory of the particular rural administration.
- Museum and tourism associations.

State and local bodies charged with protecting the cultural heritage of Kyrgyzstan have the right to stop any type of economic development work that threatens cultural sites or fails to comply with regulations regarding their protection. If archaeological remains are discovered during the course of construction or roadwork, the company or organization involved must suspend its work, inform the relevant local authorities, and undertake all measures to ensure protection of the archaeological site. State bodies, legal entities, and individuals guilty of breaking the rules of protection or of misuse of cultural heritage sites are subject to administrative or criminal charges according to the laws of the Kyrgyz Republic.

Funds to support preservation activities come from the national budget, local budgets, and private investments. Seminars, courses, and workshops are organized to expand the country's expertise in conservation and management of culturally important sites.

National and World Heritage Sites

According to the Ministry of Culture, there are more than 2,000 historical monuments of local significance in the Kyrgyz Republic. As of January 2006, 583 historical and cultural sites of national significance have been identified. They are divided into the following categories:

Historic	55
Artistic	23
Architectural	101
Archaeological	402
Natural	2

Six of these sites have been submitted to the UNESCO World Heritage Tentative List. They are the Lake Issyk-Kul basin, Suleyman-Too, the Uzgen architectural complex, the Shakh-Fazil mausoleum, the Saimaly-Tash petroglyphs, and the Burana minaret.

According to the 1999 law on protection and use of historical and cultural heritage, the Kyrgyz Republic retains ownership of the country's sites that have been submitted to the World Heritage Tentative List. These sites cannot be privatized, and they have special legal status stipulating that they can be used only for scientific, educational, and tourism purposes. Furthermore, because the nominated sites represent the historical-cultural heritage of the Kyrgyz Republic,

they are registered with the State List of historical-cultural sites of national significance.

Looking to the Future

Despite current social and economic difficulties, Kyrgyzstan is taking concrete steps toward the preservation and promotion of its rich cultural heritage. In this regard, Kyrgyzstan is interested in developing contacts for the exchange of experience in the areas of preservation, interpretation, and management of historically and culturally important sites. Kyrgyzstan especially needs help to develop conservation technologies and create computer-based scientific documentation systems, as well as to train national staff in the areas of maintenance, restoration, and preservation of cultural monuments.

Notes

- 1 This date comes from the account of the travels of Xuan Zang (602–64 C.E.), although other historical documents date the trade routes to the fourth century C.E.
- 2 The *National Geographic Atlas of the World* (8th ed.) gives the spellings *Shö* for Chui and *Ysyk-Köl* for Issyk-Kul.
- 3 Born into a poor family, Xuan Zang became a monk at the age of eleven. Since international travel was forbidden by the emperor, Xuan Zang disguised himself and joined a group of central Asian merchants heading west along the Silk Road between 627 and 643. His detailed travel accounts from the Silk Road provide reliable information about distant countries whose terrain and customs were known at that time in only the sketchiest way.
- 4 John of Plan Carpin (Giovanni da Pian del Carpini), a Franciscan monk, was sent on a papal mission to the Mongol Empire by Innocent IV. He journeyed to Karakorum and China in 1245 and returned in 1251.
- 5 William of Rubruck was a Franciscan monk sent by King Louis IX of France in 1255 to preach Christianity to the East and to establish contact with Nestorian Christians in the Mongol Empire. The account of his journey is considered the most authentic description of the empire before the conquest of China.
- 6 In 1961 a Kyrgyz archaeological expedition headed by P. N. Kozhemyako discovered a Buddhist temple complex at Krasnaya Rechka. It became known as the "first" Buddhist temple so as to distinguish it from the second temple discovered later that year.

References

- Bernstam, A. N. 1952. *Istoriko-archeologicheskie ocerki Central'nogo Tjan-Sanja i Pamiro-Alaja = Historical and Archaeological Review of Central Tian-Shan and Pamir-Alai*. Materialy i issledovanija po archeologii SSSR no. 26. Moscow [u.a.]: Izdat. Akad. Nauk SSSR.
- Kyrgyz Archaeological Expedition. 1989. *Krasnaia rechka i Burana: Materialy i issledovaniia Kirgizskoi arkeologicheskoi ekspeditsii = The Red River and Burana: Studies and Data Collected by the Kyrgyz Archaeological Expedition*. Frunze: Izd-vo "Ilim."
- Kyzlasov, L. R. 1959. Arkheologicheskie issledovanija na gorodishche Ak-Beshim v 1953–1954 gg. = Archaeological research at the ancient town of Ak-Beshim, 1953–54. In *Trudy kirgizskoi arheologo-etnograficheskoi ekspeditsii*, vol. 2, 155–242. Moscow: Izd-vo Akademii nauk SSSR.
- Vinnik, D. F. 1974. Architectural monuments of the Issyk-Kul basin in XIII–XV. *Pamiatniki Kirgizstana* 2.
- Ziablin, L. P. 1961. *Vtoroi budiiskii khram Ak-Beshimskogo gorodishcha = Second Buddhist Temple of Ak-Beshim*. Frunze: Izd-vo AN Kirgizskoi SSR.

Visitor Surveys at Mogao: Pioneering the Process, 2002–2004

Li Ping, Sharon Sullivan, Kirsty Altenburg, and Peter Barker

Abstract: *One of the major problems facing the Mogao Grottoes is the rapid increase in visitors. This increase poses a number of problems: it may threaten the conservation of the fragile site, and overcrowding and pressure on available facilities may impair visitors' experiences at the site and their appreciation of its cultural value.*

Site conservation and visitor satisfaction and education are major objectives of the visitor management and interpretation subplans in the master plan for the Mogao Grottoes. To design strategies that effectively meet these objectives, the managers at Mogao decided that it was essential to systematize visitor information and to collect it regularly and in detail. Research into visitor origins, types, experience, and behavior at the site is as vital to successful management and conservation of values as is research into the physical condition of the cave paintings and sculptures. This paper describes the pioneering efforts of the staff at Mogao to design and conduct visitor surveys, and it reports and discusses some of the results obtained.

The rapid increase in the number of visitors to the Mogao Grottoes poses a number of problems for managing this World Heritage Site, which Altenburg and colleagues address in a related paper in this volume, “The Challenge of Managing Visitors at the Mogao Grottoes.” Overcrowding threatens the fragile environment of the Mogao Grottoes and also puts pressure on site facilities and reduces visitors' experiences and their appreciation of the cultural values the site has to offer. The issue facing the Dunhuang Academy Reception Department, which is responsible for visitor management at the site, is how to effectively use the site to educate the public and allow more people to experience the outstanding culture

at Dunhuang while at the same time improve conservation of the grottoes.

The Reception Department has been looking at these issues for some time, recognizing that detailed data were needed about visitors, including where they came from, flow patterns, expectations, their experiences at the site, their behavior, and the level of satisfaction and education they gained from their visit. The department had been receiving information on visitors from a number of sources, including the observations of Mogao staff guides,¹ data on visitor numbers, and feedback from tourism authorities and visitors themselves, but these data needed to be collected regularly and in more detail. Such visitor research is as vital to successfully managing the site and conserving its values as is research into the physical condition of the cave paintings and sculptures.

To obtain more detailed visitor information, the Reception Department has undertaken surveys to learn about visitors' experiences and obtain their evaluations of the management and services provided at the site. With this information, it hoped to uncover problems, improve management and the level of services provided, and improve implementation of the academy's general policies on conservation, research, and education. Specifically, the department hoped to apply this information to carry out the objectives outlined in the Mogao Grottoes Conservation Master Plan, 2005–2025, foremost among them site conservation, visitor satisfaction, and education.

Beginning in mid-April 2002, under the leadership of the Dunhuang Academy and with support from the General Office, the Research Institute, and the Grottoes Management Department, the Reception Department worked with colleagues from the Australian Heritage Commission to design



FIGURE 1 The Mogao guides who accompany visitors to the caves and provide commentary.

major visitor surveys that would be systematically administered. Five surveys were undertaken in which visitors filled out questionnaires: four surveys provided general data to assist visitor management; one survey asked visitors specific questions relating to conservation issues in the caves.² In addition to these surveys, Dunhuang Academy staff conducted an observational study of visitors during a national holiday week to examine their behavior under crowded conditions.

All visitors who enter the caves must be accompanied by a Mogao staff guide (fig. 1). Individuals who are not in tourist groups normally have to wait at the entrance to the Grottoes Zone for approximately fifteen minutes until enough visitors arrive to make up a group of about ten to twenty.³ The visitor experience is affected by the length of the visit, the number of caves visited, the number of people in the group, and the style and content of the commentary provided by the guide.

Survey Design and Distribution

The questionnaires used in the five surveys were not identical. Four of the five surveys used general questionnaires that varied depending on whether visitors were surveyed during normal operating times between the low and high tourist seasons, when the flow of visitors is moderate; during the high tourist season; or during one of the national holiday weeks in May and October, when the cave visitation system

changes to accommodate high visitor numbers and the visitor experience is qualitatively different.

Each of the four general questionnaires contained twenty-two questions. The first eight questions and the last question of these questionnaires were identical and designed to obtain information on gender, age, domicile (in China, this refers to residents of Hong Kong, Macao, and Taiwan) or nationality, whether the visit was in a group or individual, transportation to Dunhuang, percentage of first-time visitors to Mogao, sources of information on Mogao, reason for visiting Mogao, and visitors' comments on their experience at Mogao. Space is provided for suggestions and criticisms.

The fifth survey was designed to test what visitors learned on-site in the high season. In addition to the standard questions, ten specific questions were designed to determine how effectively the guides communicated basic knowledge and information about the site to visitors.

The surveys undertaken during the national holiday weeks contained specific questions on visitor experience at the site, reasons for visiting the site at that time, and, since visitors were not accompanied by staff guides, how much visitors had learned about the site. One question asked visitors for their "opinion of the conservation of the site." A separate survey focused on specific questions relating to conservation issues in the caves.

The questionnaires were designed to be short—visitors should be able to fill them out without reducing their visit time—yet obtain the specific information needed to improve management of the site. They were based on international examples and experience but also relied on the local knowledge of staff members and their view of the specific information needed. The questionnaires were in English, Chinese, and Japanese.

To encourage participation in the surveys, small souvenirs were provided to everyone who completed the questionnaires. The majority of visitors responded positively and supported the survey effort.

Visitor Surveys

April 17–29, 2002. The questionnaire for this survey was developed to collect standardized baseline information for visitor management use. It was designed to be conducted during normal operating times, such as late April, when visitation is moderate and visitors do not put too much pressure on the Mogao guides. Data collected from this questionnaire provided insight into the visitor experience, as well as

an overall evaluation of site management and services. The guides distributed the questionnaire after finishing their commentary in the caves. Visitors completed the survey at the site with the guide present.

August 1–6, 2002. This questionnaire focused on education and was designed to test what visitors learned on-site from the guides. The survey was undertaken in the high season to test the effectiveness of the guides' commentary when the site was crowded. The guides distributed the questionnaire after finishing their commentary in the caves. Visitors completed the survey at the site with the guide present.

May 1–5 and September 30–October 5, 2002. These two surveys were conducted during national holiday weeks. Because of the large number of visitors at this time (figs. 2, 3), the management system is changed, allowing access to fifteen open caves, with two or three staff guides stationed in each cave to provide continuous commentary. Because of these changed conditions, a different questionnaire was needed to seek feedback on visitor experience and level of satisfaction on the issues of overcrowding, noise, quality of guide commentary, and provision of other services. Also, a different method was used to distribute the questionnaires as the guides were fully occupied in the caves providing commentary. Staff distributed and collected the completed questionnaires at the entrance to and exits from the Mogao site (at the Nine-Storey Pagoda and the Small Archway). There was less

opportunity for the Mogao guides to influence the visitors' comments, as the latter were not being guided in groups, as occurs at all other times. Data from these surveys provided information on visitors' experiences, their views on conservation, and their degree of satisfaction with visitor services. It should be noted that in April and May 2002 both domestic and international tourists were surveyed, whereas in August and October 2002 only domestic tourists were surveyed.

May 1–6, 2004. During the national holiday week in May 2004, the Reception Department surveyed visitors using questionnaires that focused on their perspectives on lighting and protective barriers in the caves (fig. 4). This provided useful information for the Visitor Carrying Capacity Study.

Visitor Observation Study

During the national holiday week of May 1–6, 2004, dedicated personnel also observed and recorded visitor behavior in cave 16 and logged visitor numbers (fig. 5). This cave was chosen because it is very large, with well-preserved Western Xia dynasty (1038–1227) paintings. It has some lighting and protective railings but no glass barriers, and it contains the entrance to the renowned Library Cave. As one of the caves that every visitor to Mogao wants to see, cave 16 provided an opportunity to study visitor behavior unobserved.



FIGURE 2 Visitors at the Mogao Grottoes during a national holiday week. At this time they are not accompanied by guides.



FIGURE 3 Crowded conditions during a national holiday week.



FIGURE 4 Visitors filling out survey questionnaires.

Survey Results

The Reception Department compiled and analyzed the survey data. Table 1 summarizes survey data on basic visitor information. Table 2 summarizes survey data on visitor satisfaction. Table 3 summarizes visitor behavior and numbers in cave 16.

Shortcomings

This was the first time the Reception Department of the Dunhuang Academy conducted formal visitor surveys at the Mogao Grottoes. Although considerable time was spent preparing the surveys and visitors actively participated in them, there were some areas that did not produce the hoped-for results. This was due to shortcomings in the survey process, as follows:

- Some people found the forms too long, which contributed to incomplete responses.
- Visitors to the site are often on a tight time schedule, particularly if they are part of a tour group, and this may also contribute to incomplete responses.
- Responses may have been influenced by the tour guides when they collected the forms. Also, visitors may not have experienced the full range of attractions at the site before filling out the forms. This problem resulted in a lack of good data on the Exhibition Center and the display on the history of



FIGURE 5 Mogao staff (left) observe visitor behavior in cave 16.

the Library Cave and its artifacts in Abbot Wang's Temple.

- Methodological problems with the education questions resulted in a lack of convincing data on the information given to visitors and how they interpret it.
- Staff probably need more formal training in administering the questionnaires.

Improvements to the questionnaires have already been made, and their effectiveness and the survey methodology will be monitored and refined as needed.

Despite these shortcomings, the surveys provided a great deal of information that has important implications for management. They have also given the staff valuable experience in survey methodology. The results have been widely discussed and analyzed by site personnel, who are beginning to use them in day-to-day problem solving and in the further development of the Mogao master plan. The implications of some of the survey results are discussed below.

Basic Visitor Information

Gender. More men than women visit the site. This is explained by visits to the site by domestic business visitors, a great majority of whom are male. The guides have noticed that when groups comprise both men and women, it is common for the men in the groups to fill out the questionnaire.

Table 1 Basic Visitor Information

National origin	Foreign: From Asia, Europe, North America, Australia Domestic: From almost all of China's provinces, autonomous regions, and four municipalities under the control of the central government
Gender	Males exceeded females, especially in April.
Age range	Broadly representative, with the majority of visitors between 14 and 45 years old
Transportation to Dunhuang	Foreign visitors: commonly by air Domestic visitors: commonly by rail
Tour groups v. independent visitors	Foreign visitors*: 80% of 30,000 people surveyed visited in tour groups Domestic visitors*: 40% of 290,000 people surveyed visited in tour groups
First-time visitors	The percentage of first-time visitors to Mogao was seasonal: During the August 2002 survey, around 20% of people were repeat visitors.† During the April and October 2002 surveys, repeat visitors accounted for less than 15%.
Sources of information about Mogao	More than 50% of visitors learned about the site through radio, television, newspapers, or the Internet.
Reason for visiting	April 2002: 90% of visitors cited tourism; 10% academic study. August 2002: 15% of visitors cited academic study. (They were mainly high school students, heritage or museum professionals, academics, or scholars. This increase in academic study visitors also coincides with peak tourist numbers visiting the site.) May 2002: 90% cited tourism. October 2002: 82% cited tourism.

*2002 data. Foreign visitors only were included in April and May 2002 surveys. In August and October 2002, only domestic visitors were surveyed.

†In August 2002, the number of tourists from Gansu province increased. They came from companies in Lanzhou, Jiuquan, and Yumen that organized short-term summer holidays for their employees. This probably explains why there were so many repeat visitors to the site that month. August is also the month when tertiary institutions have their long summer break, and many teachers and students from fine arts tertiary institutions visit the site to carry out research, some of whom come for the second or third time.

First-Time Visitors. Most of the visitors had not been to the site previously. Information and services need to be provided that are suitable for both domestic and foreign tourists visiting for the first time. Tour guides need to engage especially first-time visitors; they need to use lively, vivid descriptions offering both general and in-depth knowledge to make visitors' experiences both enjoyable and educational.

Students and Scholars. While most visitors come to Mogao for tourism, a small but significant number are students and scholars wanting to learn about the caves in a more formal academic sense. This requires the ability on the part of site personnel to provide specialized guidance.

Time Pressure. Both domestic and foreign tourists visit a range of other attractions in the region. Most visits to the Mogao Grottoes are concentrated into a short time, which can lead to overcrowding and poor service.

Visitor Age Range. The majority of visitors are between the ages of fourteen and forty-five. They tend to be independent and active, which has implications for addressing their needs and understanding their behavior on-site.

Tour Groups versus Independent Visits. Forty percent of domestic tourists come in tour groups. Although foreign visitors did not participate in every survey, the data collected indicate that 80 percent traveled as part of a group. A professional guide from the tourist agency accompanies the agency's tour groups. The tourist agencies are quite familiar with the procedures and arrangements involved in visiting the site, and their guides work well with the site tour guides. Tourist agencies also provide advance information about the arrival of tourist groups. For these reasons, tourist groups are easier than independent visitors to manage and organize.

However, few tour groups visit the other exhibits on the site, such as the Exhibition Hall, which features cave replicas,

Table 2 Visitor Satisfaction

Satisfaction with services	<p>April 2002: 96% of visitors were satisfied with or approved of the tour guide's commentary, and most visitors were satisfied with the car park and ticket office. (This high level of satisfaction appeared to be related to the degree with which the guide was present while questionnaires were being completed.)</p> <p>May and October (national holiday weeks) 2002: Only 65–70% were satisfied overall (during the holiday weeks, guides did not supervise visitors filling out the questionnaires). Dissatisfaction increased during the holiday weeks. Issues included flashlight rental, entrances, baggage checks.</p> <p>April, May, and October 2002: 33%, 25%, and 16% of respondents, respectively, were critical of the toilets; only 40% said they were satisfied.</p> <p>Exhibition Hall: Only 23.7% of respondents answered this question. More than 75% of the visitors who did visit the Exhibition Hall were extremely satisfied with it.</p> <p>Food purchases and shopping: The survey forms were collected before many visitors had purchased food or been shopping, which explains why only 13.4% and 17.2% of visitors completed these questions.</p>
Satisfaction with the caves	<p>20% of respondents would like more time to visit the caves and more free time to see the site.</p> <p>30% would like to see more caves.</p> <p>30% preferred that groups entering the caves be limited to 10 individuals.</p> <p>17% of respondents wrote specific comments at the end of the questionnaires, most commonly identifying problems with lighting, air quality, and noise.</p>
Site satisfaction during national holiday weeks (May and October 2002)	<p>Visitors managed to see only 50% of the 15 open caves, citing difficulty in identifying the cave locations.</p> <p>55% of May visitors, and 36% in October, complained that the large number of visitors negatively impacted their visit. Problems identified included overcrowding in the caves, visitors unwilling to line up, and the wait to get into caves.</p>
Satisfaction with conservation efforts	<p>More than 50% of respondents indicated that more should be done to conserve the caves and in a more comprehensive manner.</p>
Satisfaction with cave lighting and protective barriers	<p>47% believed that improved lighting in the caves would enhance viewing of the wall paintings (most caves are unlit and viewed with flashlights).</p> <p>53% believed that electric lighting should not be installed because of its impact on conservation of the wall paintings.</p> <p>53% believed that the protective glass barriers were an advantage to cave visitation and conservation.</p> <p>47% believed thae barriers impinged on viewing the wall paintings.</p>

Table 3 Visitor Observation Study in Cave 16

Visitor Origin	Total Visitors Counted	Visitors Touching Wall Paintings
China	16,683 (91.6%)	705 (4.2%)
Foreign	1,529 (8.4%)	3 (0.2%)
Total	18,212	708



FIGURE 6 Domestic visitors exploring Mogao independently.

and the Middle and Lower Temples, which cover the history of the Dunhuang Academy and conservation at the site. This is an issue that needs to be worked out with the tourism authorities. Some tour groups do visit the Exhibition Hall, but the vast majority are immediately returned to Dunhuang by tourist agency guides after visiting the caves and shopping.

The survey data show a growing trend among domestic visitors to visit independently, and this has important implications for site management (fig. 6). Independent visitors cannot be planned for as easily as tour groups. Although people taking part in group tours had the same general aims as individual travelers for their visits to Mogao, individual tourists tended to have a greater range of needs and expectations. For instance, individuals might have special research or academic interests in Chinese history, art, religion, or music. Especially difficult to organize and manage are independent visitors who require commentaries in foreign languages. The Reception Department is not well positioned to deal with the less common languages, such as Korean or Italian, and this is an area being worked on.

Source of Information about Mogao. More than half of the survey respondents learned about the site through the media—radio, television, newspapers—or on the Internet. This means that the media can be effectively used to tell visitors about the importance of the site, its management, and its services before they arrive.

Visitors' Basic Knowledge about Mogao. More than 95 percent of visitors correctly answered questions designed

to test basic knowledge of the site. However, for various methodological reasons, this information is not always accurate; therefore, these questions need to be redesigned.

Satisfaction with Services. Visitor satisfaction with the provision of services varied. During the holiday weeks in May and October 2002, the number of dissatisfied visitors increased dramatically, peaking in October. There were some obvious problems identified with the entrances, baggage checks, flashlight rental, and toilets. Dissatisfaction with flashlight rental (most caves are unlit) was identified as a problem that urgently needed to be solved, as the poor quality of the flashlights has a direct impact on the quality of the visitor experience. This finding has implications for work under way as part of the Carrying Capacity Study to determine whether to provide more lighting for visitors in the caves.

Most visitors were basically satisfied with the car park arrangement and ticket office. However, visitors rated as only “average” the service received at the entrance, baggage check, and flashlight rental. The survey identified a very high level of dissatisfaction with the toilets, although this decreased to some extent in October 2002, probably as the direct result of no longer charging for their use. Accurate figures were not obtained on satisfaction with the Exhibition Hall and food and shopping. A more targeted survey is needed to obtain accurate figures on visitation to the Exhibition Hall and purchasing food and shopping.

These findings highlight the need to reorganize services to make them more efficient and to provide training to attendants in these areas to more effectively deal with visitors. Management is already taking steps to improve services. Providing average or sometimes below-average services is unsatisfactory at a World Heritage Site. Management is striving for excellence in all areas.

Satisfaction with Staff Tour Guides. Visitors appreciated the service they received from the staff tour guides. The high degree of satisfaction or approval of the guides' commentaries in April 2002 may represent some bias in the results because of the guides' involvement in distributing and collecting the questionnaires. Satisfaction fell 25 percent during the holiday weeks in May and October 2002, when completion of questionnaires was not supervised by the guides. The survey techniques should be refined to clarify this point. The survey results do suggest that the tour guides are well trained and consider dealing effectively with visitors among their major roles.

Satisfaction with Site Experience. Overall, visitors were satisfied with their experience at the site. Some

visitors would have liked to spend more time in the caves and hoped that tour group numbers at the caves could be limited. These suggestions are being considered, although they are difficult to resolve at the present time. The number of visitors to the caves and the length of the visits are limited by the number of tour guides; because of conservation concerns, visitors are not allowed to walk into any cave at will. The conservation of the site is given absolute priority, and tour guides are asked to inform visitors about the significance and importance of conserving the site to gain their understanding and support.

The national holiday weeks pose significant challenges to visitors' site experience. At other times, the majority of visitors felt they had benefited from their visit. However, in May and October 2002, when visitor numbers were high, only half the visitors managed to see all of the open caves,⁴ and their satisfaction rating dropped significantly (only 55% were satisfied in May; 36% in October). Likewise during this period, visitors identified overcrowding in the caves and on the walkways, the level of noise, and deterioration in the quality of services as negative influences. It seems clear that the major influx of tourists during the holiday weeks has a significant deleterious effect on visitors' enjoyment and on their ability to appreciate the site.

With the recent expansion of the Dunhuang airport and the future completion of the railway line into the town of Dunhuang, visitor numbers can be expected to increase dramatically. Findings from the surveys about visitors' experiences at the site will be crucial in discussing with tourism authorities ways to mitigate crowding problems while also continuing to provide and *improve services to visitors*.

Satisfaction with Lighting. Poor lighting in the caves was identified by over 50 percent of visitors as the factor that influenced their experience most negatively. This confirmed that poor lighting significantly impedes visitors' appreciation and understanding of the site. But when asked whether they approved of the trial caves lighted by electricity, 53 percent of visitors were concerned about the possible negative effect on the wall paintings and felt that flashlights were more conservation-friendly. This information will be an important consideration in the experimental work under way to provide increased lighting in some caves while ensuring their ongoing conservation.

Satisfaction with Glass Barriers. Visitors were ambivalent about the use of glass barriers to protect the site. Many felt that the barriers impeded their view but that their removal might affect conservation. The tour guides' observa-

tions of the number of people touching the paintings in the unprotected areas was confirmed during informal observations of visitor behavior during the holiday week (May 2002) and during the visitor observation study in cave 16 (May 2004). This finding indicates that this issue requires careful consideration.

Satisfaction with Conservation. When asked about the conservation of the site, more than half the survey respondents said more should be done to conserve the caves and that both a comprehensive approach and more detailed conservation methods should be adopted. Visitors expressed concerns that the environment and crowding in the caves are endangering the paintings.

Some visitors even suggested limiting the number of caves that are open to the public in order to conserve the site better. The results show that the visitors' level of education is continuing to rise and that there is some awareness about the importance of conservation. From the specific comments visitors provided about the site and the conservation of the caves, they appear to be well educated and understand the conservation issues well. This feedback from visitors is encouraging as it indicates their appreciation for the site and the high value they place on it. It provides important information for site managers to use in their discussions with municipal and regional colleagues about the conservation of the site.

Visitor Behavior. The observational study conducted in cave 16 showed that only a small percentage of people touched the wall paintings, but extrapolated over time, this behavior will obviously have significant consequences. Touching is much more likely to occur during the peak season or during long holiday weeks when the caves are very crowded. This finding reinforces the need to improve the booking system and use other methods to reduce crowding and ensure adequate supervision. The observations also demonstrate the important role of the guides and managers in protecting the paintings when there are no glass barriers and the need to improve visitor education regarding the conservation of wall paintings.

Conclusion

The visitor surveys and the visitor observation study conducted in cave 16 have provided management with useful information about the experiences and behavior of visitors at the Mogao Grottoes. This information has already been used to improve visitor services.

The Reception Department plans to administer surveys on a regular basis to continue providing data for the visitor carrying capacity study and to assist in improving management's work at the site. The next tasks are to refine and readminister the surveys, design a manual for administering the surveys, and develop an appropriate training program that will ensure regular and consistent collection of data over time.

- 2 A similar survey, asking specific questions relating to visitors' experiences at the Exhibition Hall, was undertaken in 2005.
- 3 The Dunhuang Academy regulations state that each tour guide should take a group of about ten to twenty visitors; groups should be taken into about twelve caves over the morning or afternoon; and the total amount of time in the caves should be about two hours.
- 4 The site covers a large area, and although there is clear signage and colored flags at the entrance to the caves, many visitors have difficulty finding the exact location of the open caves.

Notes

- 1 All visitors to the caves are accompanied by Mogao staff guides who provide information and commentary on the history, conservation, and use of the site. Tourist groups may also be accompanied by their own tour guide, but the guides referred to in this paper are Mogao staff members.

The Challenge of Managing Visitors at the Mogao Grottoes

Kirsty Altenburg, Sharon Sullivan, Li Ping, and Peter Barker

Abstract: Tourism in China has been increasing dramatically in recent years, and the exquisite paintings and sculptures of the Mogao Grottoes have become a major attraction for Chinese and foreign visitors. This paper presents information on the increase in and seasonal fluctuations of visitor numbers and the serious overcrowding during peak holiday periods. It describes the overall concept of visitor management with targets and strategies to improve the visitor environment and relieve the extreme pressure on the caves during peak seasons. These strategies include regular training for tour guides, multilingual tours, well-planned tour routes, and the rotation of caves that are open to visitors. In an effort to ensure that visitors enjoy and appreciate the artistic value of the caves, we conducted visitor surveys and incorporated their suggestions and comments into the visitor management program. Timely improvements have qualitatively enhanced the visitor experience. We conclude that effective conservation of the site must take into account sound visitor management to ease the growing conflict between tourism and preservation. We describe plans and proposals to enhance this effort.

The Mogao Grottoes are a cultural resource of inestimable value to humanity. The grottoes are an irreplaceable and nonrenewable resource with unique historic, artistic, and scientific significance. Tourism, both domestic and international, has developed rapidly in China over the past few years. This paper discusses the specific challenges associated with the rapid development of tourism for the site managers at Mogao.

Conservation of the Mogao Grottoes

The work of the Dunhuang Academy commenced in 1944 with a focus on research and the conservation of the Mogao Grottoes. The site was inscribed in the World Heritage List in 1987, meeting all six criteria for cultural values. The Chinese government approved the formal opening of the Mogao Grottoes to the public in 1979.

Over the past two decades, tourism has increased at Mogao, making visitor management and interpretation an increasingly important aspect of site management. The director of the Dunhuang Academy, Fan Jinshi, has been central to this process, as related in other papers in this volume. She played a key role in the development of the China Principles, published as the *Principles for the Conservation of Heritage Sites in China* (Agnew and Demas 2004), and provided leadership in understanding the importance of identifying and clarifying cultural significance to managing the values of the site.

Mogao Grottoes Master Plan

Using the China Principles to guide the process, Fan Jinshi actively endorsed and contributed to the development of the Dunhuang Mogao Grottoes Conservation and Management Master Plan 2000–2010. The master plan identifies the cultural values of the site, assesses its opportunities and threats, and develops goals and objectives and subplans to realize these objectives. Visitor management and interpretation is one of the subplans.

Mogao Grottoes Values

The statement of significance in the master plan identifies the historic, artistic, scientific, and public values of the Mogao Grottoes, which are among the most important historic and cultural sites on the Silk Road. It provides extensive information on the official history of China, the Dunhuang region, and the construction of the grottoes at Mogao. It also provides information on Buddhism and the practice of other religions in China.

The wall paintings in the caves provide the oldest continuous, comprehensive, extant record of Buddhist art in the world, as well as an unparalleled record of every aspect of ancient Chinese lifestyles and early technological achievement, including agriculture and warfare. In addition to presenting a unique aesthetic experience, they also reveal the exchange, integration, and development of Chinese and foreign artistic styles and reflect the sinification of Buddhist art.

The Mogao Grottoes encompass important research values on traditional Chinese culture and arts and on the extent and magnitude of artistic categories and styles, in particular those predating the tenth century. In addition to their literary significance, works from the Library Cave, such as poems, essays, and Buddhist narratives and songs, which date from 400 to 1000 C.E., provide an important source of information for research on the linguistic transition from classical Chinese to vernacular Chinese literature.

In regard to public and social values, the Mogao Grottoes are a treasure house of traditional Chinese culture and a preeminent place to visit for Chinese and foreign Buddhists. Mogao is highly valued by the local population. It serves as a creative inspiration to contemporary artists and provides all visitors with a unique cultural experience in the appreciation of ancient art and culture. Moreover, visitation at the site provides economic benefits to the local community, as well as to the province and nation.

The richness, age, and importance of the site, and its consequent World Heritage listing, give us a potential management conflict. Large numbers of people want to visit the site, and it is important that they do so to understand and appreciate its values, but the overwhelming numbers pose a threat to the very existence of these outstanding values.

Tourism Pressures on Culturally Important Sites

China is now among the ten most visited tourist destinations in the world. The Chinese government's Western Regions

Plan,¹ based on developing tourism as one strategy to grow the economy and raise living standards, exerts great pressure on sites such as Mogao to continue to expand tourist facilities and increase visitor numbers. The development of national infrastructure, including the recent expansion of the Dunhuang airport's facilities and the construction of the rail link, has enhanced the accessibility of Dunhuang and the Mogao Grottoes and other regional sites. This effort by the central government and the province to stimulate the economy is raising the standard of living of people in the region. However, unless this effort is carefully managed, with proper recognition of the heritage values of Mogao, the resulting rapid expansion of tourism can challenge the integrity of the site.

The development of the market economy and growing Chinese affluence is stimulating recreational tourism. Increasingly, large numbers of domestic tourists are traveling within China to places such as Dunhuang that were formerly considered remote. In addition, the number of international visitors to China is growing as tourists from the Chinese diaspora, Japan, and the West seek their traditional roots or an exciting new experience. Global cultural tourism promotes specialist visits to Silk Road sites and religious tours. Mogao is regarded as the spiritual home of Buddhism in East Asia and therefore attracts both domestic and international tourists, in particular from Japan.

Escalating visitor numbers are putting inexorable pressures on the Mogao site—its physical fabric; the caves, with their magnificent wall paintings and sculptures; and its fragile desert environment. Staff who are responsible for the long-term conservation of the site, its presentation and interpretation, and the enjoyment and safety of visitors are faced with intense management challenges. The rapid increase in the numbers of tourists, especially during the two national holidays—the first week of May and the first week of October (known as “Golden Weeks”), which have been heavily promoted by the government to stimulate the market economy—is causing loss of control, and effective management and monitoring at Mogao is inadequate.

Visitors at Mogao Grottoes

More than three million tourists from China and from more than eighty countries and regions have visited the Mogao Grottoes since it was opened to the public in 1979. Visitor numbers built up gradually through the late 1980s and 1990s to reach more than 200,000 in 1998, and by 2000 the number

FIGURE 1 Increase in visitor numbers at Mogao, 1979–2002.

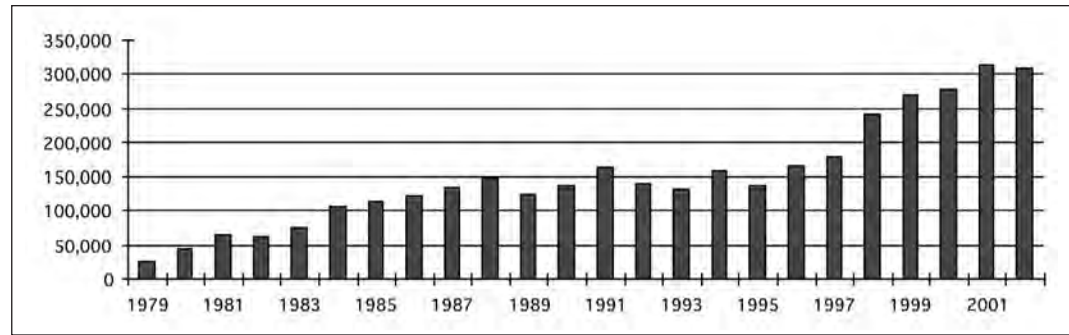

Credit: Dunhuang Academy

FIGURE 2 Increase in international visitors at Mogao, 1979–2002.

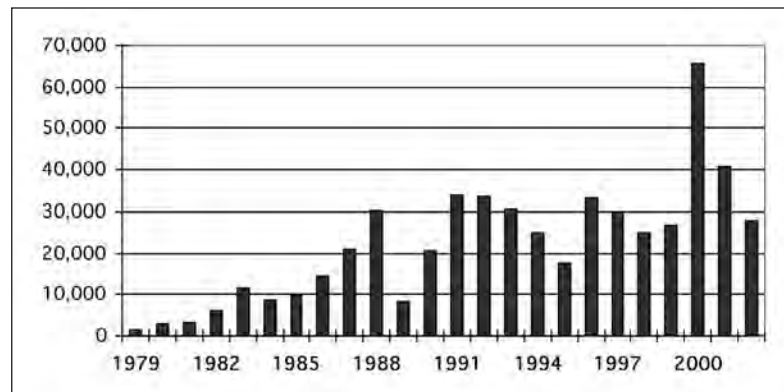

Credit: Dunhuang Academy

FIGURE 3 Number of visitors at Mogao each month in 2002.

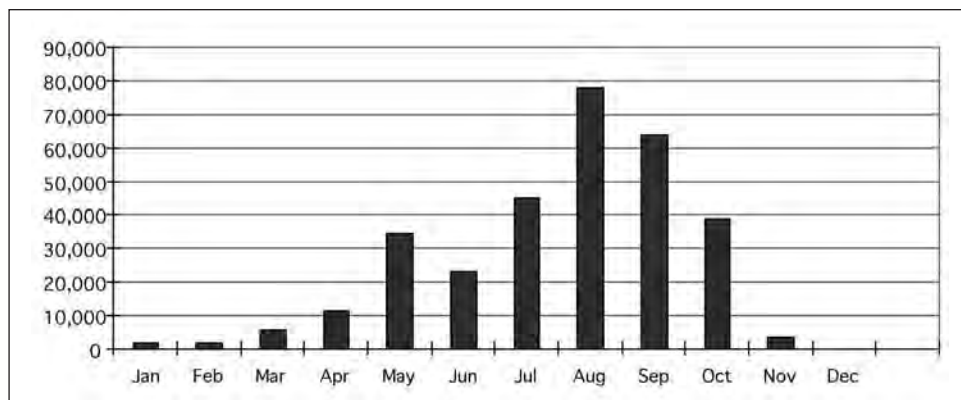

Credit: Dunhuang Academy

exceeded 300,000 (fig. 1). For the past two decades, the number of overseas tourists visiting the Mogao Grottoes has grown steadily, reaching a peak in 2000 (fig. 2).

Visitors to the site are unevenly distributed throughout the year, as shown in figure 3. Visitors are mainly concentrated in the period from July through September. In 2002, of a total of 308,715 visitors, 187,934 (61 percent) visited during this three-month period. There are few visitors in winter.

Visitors are heavily concentrated in the peak season, and they are spending less time at the site. Before 2003, visits normally peaked in the morning, from 8:00 to 11:00, because of airline, railway, and other transportation schedules. Tourist companies typically adhere to tight schedules, with just one day in Dunhuang. Tourists are taken in the morning, when it is cooler, to sites close to the town, such as Crescent Moon Lake and Mingsha Mountain, and then in the early afternoon, to escape the heat, to the Mogao caves, before their departure on the evening train. These visits are restricted by transportation schedules as well as by the hot summer climate of Dunhuang. In 2003 most visitors were concentrated in the period from 1:00 to 3:00 P.M. This creates pressures for the visitor management staff.

Visitor Management

Visitor management at the Mogao Grottoes is organized into two branches: the Reception Department and guide-narrators and the Academy Office, which is responsible for ticket sales and cave management. Each branch is headed by the Dunhuang Academy director and deputy director, who chair joint meetings at which goals and strategies are developed.

Dunhuang Academy trains excellent guide-narrators who accompany all visitors. In addition to providing information in a number of languages, they supervise the safety of visitors and site security. The guides describe the richness of the arts and culture of Dunhuang to domestic and international visitors, playing a key role in the visitor experience of the site. They also play a role in the promotion of China's tourism industry and in the development of the local economy. While commercial guides may accompany tours to the site, each group must be led by a Dunhuang Academy narrator-guide.

The academy continually analyzes the visitor situation at Mogao, and it has taken a number of steps to improve visitor management, trying to keep pace with the rising visitor pressure and expectations. Forty caves and twelve visitor routes through the site have been carefully selected and



FIGURE 4 The entrance to the Xia Temple, which houses the Library Cave exhibition. The exhibition provides valuable information on the history of the Library Cave and relieves visitor pressure on the caves.

developed to maximize visitor appreciation of Mogao. A systematic management regime is in place for these caves, and the infrastructure has been improved. An exhibition center with replica caves has been built to reduce the pressure on the caves. In 2003, to further ease visitor congestion, the Xia Temple, with displays about the Library Cave and its wealth of documentation and information, was opened to the public (fig. 4). The Library Cave, one of the richest finds in the world, was discovered walled up behind a hidden doorway in 1900 by Abbott Wang. The cave housed as many as fifty thousand documents: scrolls, printed books, paintings, textiles, and silken banners with mainly Buddhist texts and images. In the decades following Abbott Wang's discovery, the treasures of the Library Cave were scattered to institutions in many countries around the world.

Impact on the Caves

A total of 492 decorated caves exist at the Mogao Grottoes, most of which are quite small. Only a limited number of these caves are suitable for public access. In the peak season of July through September and during the two national holiday weeks, visitors put enormous strain on the staff and the site's resources. The caves become overcrowded, increasing



FIGURE 5 Overcrowding in the caves can damage the fragile wall paintings and diminish visitor experience.

the temperature and relative humidity inside the caves, causing damage to the wall paintings, and at times causing both guides and visitors to faint (fig. 5). Investigations are continuing to determine whether visitors have an impact on the physical fabric of the caves.

During peak visitation periods, large groups interfere with each other and make it difficult for guides to carry out their work. Noise levels become unacceptable, and the narrow access pathways become congested, inhibiting the flow of visitors.

The wall paintings and sculpture are extremely fragile, and damage is irreversible (fig. 6). The caves are highly susceptible to damage, as well as vandalism, so that, in addition to providing the narration, the guides are required to be vigilant and maintain security. The glass protective screens are intrusive and, if broken, pose a potential threat to the safety of fragile wall paintings and statues (fig. 7). Poor lighting hinders visitors' appreciation and understanding of the wall paintings.

Normally during the peak season, forty caves are open to the public, including the three special caves that all visitors want to see—the Library Cave (cave 17), the Standing Buddha in the Nine-Storey Pagoda (cave 96), and the Reclining Buddha (cave 130)—and ten caves that are used to regulate visitor traffic. However, as visitors often tend to be concentrated into one particular period of the day, there are often five hundred or six hundred visitors on-site each



FIGURE 6 A tourist guide pointing to a feature on the wall painting. Damage caused by touching the wall paintings increases during holiday periods.

hour, so that each guided tour consists of twenty people. More than thirty guided tours take place at one time in the Grottoes Zone, the area on the western side of the Daquan River where the caves are located. In caves 428, 148, 61, and 96, for example, three to four groups may visit at the same



FIGURE 7 Inadequate lighting and intrusive glass screens diminish visitor appreciation and understanding of the wall paintings.

time, diminishing the visitor experience and the quality of the narration.

During times of high visitor numbers, some of the magnificent smaller caves, such as caves 328, 329, and 320, are opened frequently to help ease congestion. During the national holiday weeks, visitor numbers exceed the site’s capacity to provide guides for regular conducted tours. Instead the guides are stationed in the open caves to provide ongoing narration, and there is a continuous flow of visitors, with the result that the entrance doors are left open for long periods.

Management

The unequal distribution of visitors to Mogao throughout the year and the large number of visitors during holiday weeks pose significant challenges for visitor management. During the national holiday week in May 2002, for example, the maximum number of visitors on one day was 5,225, exceeding the expected carrying capacity by 2,225.

Special strategies have been put into place to deal with high visitor numbers, such as opening fifteen caves rather than permitting visitors to be guided to ten caves. Visitors find their own way to the open caves, each of which has two or three guides permanently stationed to provide continuous narration. However, when the carrying capacity of the caves is exceeded, these measures are not successful, as was demonstrated in May 2002, when visitors expressed dissatis-

faction with their experience at Mogao. (Visitor dissatisfaction is discussed in Li Ping et al., “Visitor Surveys at Mogao: Pioneering the Process, 2002–2004,” this volume.)

Challenges to Visitor Management

Visitors prefer to visit the actual caves, so there is not significant attendance at the replica caves in the exhibition center. Encouraging tourists to visit the exhibition center would reduce pressure on the caves. The distribution of guides for tour groups, individual travelers, and domestic and overseas visitors is another difficult area for site management, worsened by the lack of liaison with tourist agencies that bring visitors to Mogao. Site managers have little information on visitors and their needs, and they do not have the tools to measure and control visitor numbers.

Visitor Management Subplan

Managing visitors to Mogao, with the aim of providing an excellent visitor experience as well as protection for the caves’ treasures, is addressed in the Visitor Management and Interpretation Subplan of the Mogao master plan. Both the subplan and the master plan have the same goals and principles. Figure 8 shows the relationship of the Visitor Management and Interpretation Subplan within the master plan.

The principles set forth in the master plan that are relevant for the subplan include the following:

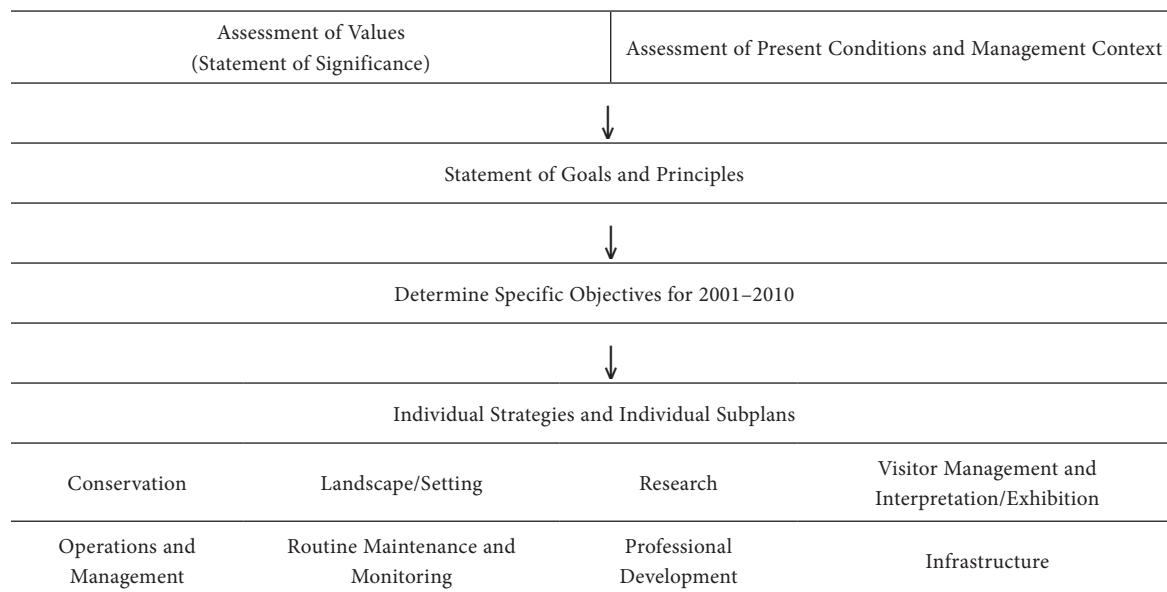

FIGURE 8 Flowchart of the Mogao Grottoes master plan.

- Physical intervention will be the minimum necessary to conserve the cultural significance of the site.
- All activities carried out at the site, including research and visitation, should not damage the site's cultural significance.
- No new structures that affect the cultural significance of the site should be built.
- Visitation of the caves must be supervised by a guide.
- No commercial activities whatsoever shall be carried out directly in front of the grottoes.
- Visitor numbers will be limited to the carrying capacity of the site.
- Use of the site must be in accordance with its cultural significance.
- Inappropriate use must be banned, including rock concerts, religious and wedding ceremonies, and the construction of new hotels.

Objectives and Strategies

Objectives and strategies have been developed to address the opportunities for and threats to visitor management and interpretation described in the master plan. Several key objectives and strategies are described below.

Carrying Capacity. The first and most important objective of the subplan is to determine the realistic carrying capacity of the site.² Determination of visitor capacity must be in accordance with the principles in the master plan, which emphasizes that when the carrying capacity is established, it will not be compromised by the desire to increase income to the site from visitors.

Once the visitor carrying capacity of the site has been established, visitor numbers and times of entry to the caves will be limited accordingly. This will ensure that visitor flow and time spent in the caves remain within appropriate limits and that the safety of the caves is guaranteed. Strategies to implement this objective include scientifically calculating the visitor carrying capacity of the caves, gradually instituting a booking system for visitors, enhancing the visitor experience in the caves by installing lighting if it is judged safe, and installing visually unobtrusive protective barriers.

Public Outreach. Other objectives and strategies are to establish a visitor's center, increase the number of new scenic spots to encourage exploration of the site, provide well-designed exhibitions about various parts of the site, and offer sufficient interpretation so that the visitor experience is both rich and enjoyable. Accurate information will be made available in a variety of formats to educate the public about

the values of the site and to improve awareness of heritage conservation. Public participation in the conservation of historic and cultural heritage will be promoted. A degree and range of service commensurate with World Heritage Site standards will be offered. A range of quality souvenirs will be developed.

Tourism. Another strategy to manage visitor numbers is to work with tourism agencies to determine the number of visitors expected on any given day. An information network with thirty-two local travel agencies has already been set up to implement a booking system for tour groups, which was established in 2005. Other efforts aim to estimate the number of individual tourists who do not come in tour groups, achieve better distribution of visitors over the site, and undertake research on visitor behavior.

Implementing Objectives

Visitor Guides. To effectively disperse visitors across the Grotto Zone during the peak season, twelve visitor routes through the site have been developed that take into account the location of the caves that are open to the public, the three "must-see" caves, the art and artifacts they contain, and the dynastic period. When visitor numbers at the caves reach an unacceptable level, the Reception Department disperses visitors to the exhibition center.

Booking System. Department has instituted a more effective booking system. Tourism agencies planning to bring more than fifty visitors at a time to the site are required to book prior to arrival. Visitors staying all day are asked to visit the caves later in the day when there are fewer people in the Grotto Zone.

Special Requests. Overseas and domestic tour groups that have made special requests to visit specific caves may be taken to those caves on a secondary list of open caves before the more popular ones, thereby helping to relieve overcrowding in the caves that are open to the public.

Visitor Center. Planning is under way to establish a visitor center where all visitors will purchase tickets and other services and be provided with interpretation and orientation material before visiting the caves. The visitor center aims to educate people so that they will understand the significance of the caves and be aware of what the site has to offer, have their needs met, and have the best possible experience at the site. In this way visitors will be helped to comply with site rules and behavior expectations.

The visitor center will enable the site managers to minimize the time visitors actually spend in the caves, thus protecting their integrity. In this way, site managers will be able

to achieve the goals of the Carrying Capacity Plan. Further, it will ensure that the management staff are able to provide better and more comprehensive service to the tourism industry, which is very sensitive about access to and service at Mogao.

Additional Site Attractions. Several attractions at Mogao help to disperse visitors around the site and relieve pressure on the caves. They include the Xia Temple and the Library Cave exhibition. The completion in 2005 of the Shang and Zhong Temple museums with interpretive displays on the site's history and the history of the Dunhuang Academy will provide visitors with more attractions and encourage them to move around the site. After geologic stabilization, the Northern Grottoes Zone, the cliff-side caves north of the cave temples, which were once used by the resident monks as living quarters, may be opened to the public, providing another major attraction for visitors.

Sharing the Benefits of Tourism across the Western Region

Looking beyond the boundaries of Mogao Grottoes, there is a great challenge facing managers, planners, and the region's leadership. The authorities are strongly supporting development of the western region to stimulate the economy and provide employment opportunities, education, and training for local people. However, it is essential to ensure that the immense economic benefits that tourism can bring are used equitably to improve the social conditions of the local people and that tourism does not diminish their lives. An identified public value in the Mogao master plan is the economic benefit that the site can bring to the regional economy. It is important to ensure that strategies are developed and implemented to provide employment and training opportunities for local people to participate in and benefit from the rapidly expanding tourist economy.

Conclusion

The Mogao Grottoes have the potential to become an exemplary model for visitor management at a World Heritage Site. Site managers are grappling with the conflicting challenges of conserving a site of inestimable heritage value to the world and at the same time ensuring that the visitor experience remains rewarding and informative. The Visitor Management and Interpretation Subplan and the Carrying Capacity Plan for the site will provide site management with tools for decision making that will be tested by the mounting demands to increase visitor numbers.

Management planning is an iterative process: there can be no perfect *final* plan, since plans need to keep evolving to meet new challenges. Difficulties will arise in carrying out the objectives and strategies of the Visitor Management and Interpretation Subplan. One danger, of course, is that more attractions at the site will create more visitor demand. Other challenges include pressures from locals and visitors to use the fragile site for recreational and religious purposes.

Monitoring and adjusting the master plan and the subplan using tools such as the visitor management survey and ongoing assessment of the condition of the site will be crucial to ensuring that any new proposals for Mogao do not adversely affect the site and its values. For the long-term protection of this World Heritage Site, effective and proactive visitor management assumes an importance that is equal to the work of our colleagues who are implementing physical conservation measures in the grottoes.

Notes

- 1 China's western region encompasses eleven provinces, autonomous regions, and municipalities under the direct administration of the central government: Shaanxi, Qinghai, Sichuan, Yunnan, Guizhou, Ningxia, Xinjiang, Inner Mongolia, Gansu, Tibet, and Chongqing. The region covers 5.4 million square kilometers, possesses 57 percent of the country's land area, and has a population of 285 million, or 23 percent of the total Chinese population. More than half of China's identified natural resources are in the western region. In 1999 the Chinese government publicly announced its official plan to develop western China, as part of the tenth Five-Year Plan. Its goal is to achieve a satisfactory level of economic development in the western part of the country in a five- to ten-year time frame and to establish a "new western China" by the middle of the twenty-first century.
- 2 The paper by Demas et al. in this volume discusses the Carrying Capacity Plan. Objectives and strategies have been included in the subplan to ensure that data on visitor expectations and needs are collected to inform the cultural component of the Carrying Capacity Plan. The paper by Li Ping et al. in this volume details the surveys of visitor attitudes, expectations, and tourism needs at the site, as well as analysis of the survey results.

References

- Agnew, N., and M. Demas, eds. 2004. *Principles for the Conservation of Heritage Sites in China = Zhongguo wen wu gu ji bao hu zhun ze* [Chinese-language document] issued by China ICOMOS; approved by the State Administration of Cultural Heritage. Los Angeles: Getty Conservation Institute.

Sustainable Visitation at the Mogao Grottoes: A Methodology for Visitor Carrying Capacity

Martha Demas, Shin Maekawa, Jonathan Bell, and Neville Agnew

Abstract: *At the Mogao Grottoes, visitor numbers have risen steadily since the 1980s while site managers have faced increasing pressure from local authorities and businesses to encourage more tourism. Although the direct and indirect impacts of visitation on the 492 painted caves were not known from systematic study, there was concern about irreparable damage from increased visitation. For this reason a carrying capacity study began in 2001 to determine the impact of visitation on the caves and visitor numbers such that, once implemented, visitors themselves would be safe and the caves and their art would not be damaged. The carrying capacity study, which addresses one of the principal objectives of the Mogao master plan, is a joint undertaking of the Getty Conservation Institute and the Dunhuang Academy and is part of a larger collaboration to apply the Principles for the Conservation of Heritage Sites in China at the site. The study required research into the mechanisms of deterioration, the impact of visitors and visitation on cave microenvironments, and visitor needs and levels of satisfaction. The study was based on the Visitor Experience and Resource Protection (VERP) methodology used by the U.S. National Park Service. The design and implementation of a research and assessment strategy includes investigations related to causes of deterioration and the impact of visitation. The results of these investigations are the basis for establishing the carrying capacity and, ultimately, the development of a long-term, adaptable management tool to respond to current and future challenges.*

As numbers of tourists at cultural sites around the world continue to grow, the need to understand the effects of visitation on cultural resources and on the visitors themselves has become paramount. Understanding the impact of visitation

is integral to developing management practices capable of safeguarding the resources and ensuring the quality of the visitor experience, both of which are necessary for sustainable tourism and long-term economic, social, and educational benefits to the sites and their local communities.

At the Mogao Grottoes, visitor numbers have risen steadily since the 1980s,¹ and site managers have faced increasing pressure from local authorities and businesses to encourage more tourism. The direct and indirect impacts of visitation on the primary cultural resource of the site, the 492 painted caves, have not been determined previously, raising concerns for irreparable damage from increased visitation. For this reason, a carrying capacity study commenced in 2001 to determine the impact of visitation on the caves and inform management practices in order to prevent deterioration and ensure the quality of the visitor experience. The study, which addresses one of the principal objectives of the master plan for the site, is a joint undertaking of the Getty Conservation Institute (GCI) and the Dunhuang Academy (DA) and is part of a larger initiative to apply the China Principles at the Mogao Grottoes.²

Defining the Parameters of the Carrying Capacity Study

The carrying capacity for a heritage site is defined not as an immutable number of visitors that a site can safely accommodate but rather in terms of the parameters necessary to prevent deterioration of the resource while maintaining a predetermined threshold of visitor safety, satisfaction, and education. This involves consideration of a number of variables: management capabilities and limitations, including

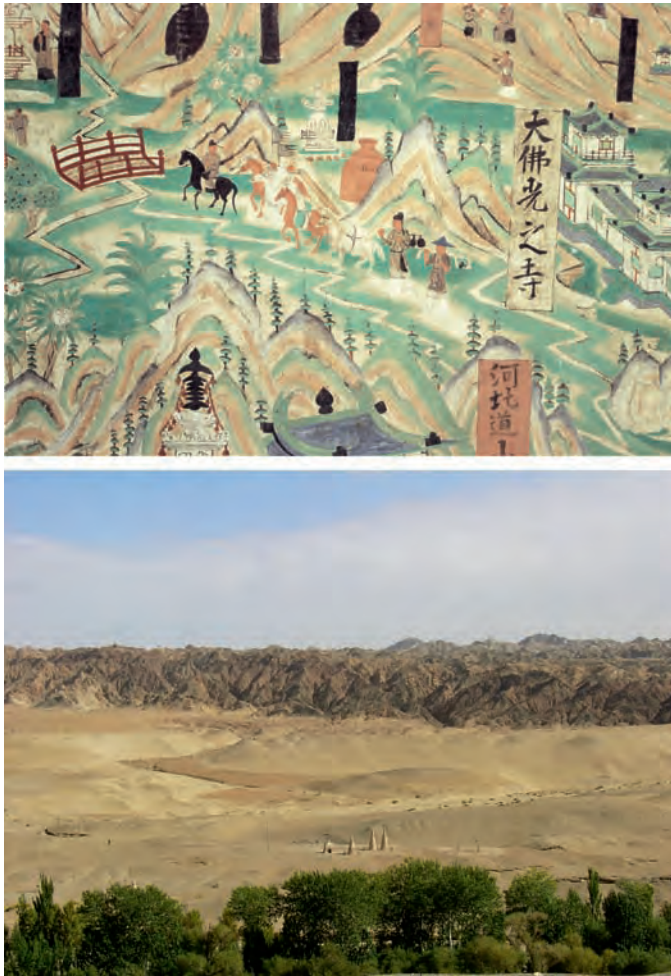

FIGURE 1 The visitor capacity study aims to protect the primary values of Mogao—the wall paintings (above, cave 61) and sculpture and the cultural and natural landscape (below). Photos: Wu Jian, courtesy Dunhuang Academy (top); J. Paul Getty Trust (bottom)

services and infrastructure; various impacts to a site, their relationship to visitation, and methods to monitor them; the degree of change or impact that is acceptable at a site; and the means by which a site's values will be protected and the quality of the visitor experience maintained while allowing flexibility to meet changing conditions. The complexities inherent in this undertaking required that clear parameters be established at the outset of the study. For Mogao, these parameters are as follows:

Values to be protected. The ultimate aim of establishing carrying capacity is to protect the primary cultural and natural values of the site (the wall paintings and sculpture of

the grottoes and the landscape) (fig. 1), as well as the quality of the experience of visitors, who come to Mogao because of those values.

Limits of acceptable change. This concept defines the degree of change or impact that will be tolerated for the resource and the visitors. As the wall paintings and sculpture in the caves are the primary cultural resource of the site and are nonrenewable, no detectable change due to visitation is acceptable. Some level of impact to the landscape and to the quality of visitor experience during peak periods is unavoidable but can be mitigated or reversed through good planning and management.

Current management policies and use zones. Existing management policies and practices relevant to carrying capacity are the number of guides, tour size and numbers, opening hours, and so on. Current use zones are the Grotto Zone (fig. 2), where the decorated caves are excavated into the cliff face, and the Visitor Use Zone, where visitor facilities and exhibition buildings are located. This study is aimed primarily at the Grotto Zone.

Time of greatest threat. This is the summer peak period of visitation, from May through October, including the two national holiday weeks in May and October.³ During this period, management and the grottoes themselves are often overwhelmed by visitors, and environmental conditions pose the greatest danger. The experience of visitors is also most heavily affected at this time.



FIGURE 2 The Grotto Zone is the protected, narrow strip along the cliff face into which the caves were carved, many of which are open to public visitation. Photo: J. Paul Getty Trust

Based on the above parameters, the carrying capacity for the Mogao Grottoes site was defined as follows:

Daily maximum number of people who can visit the Grotto Zone without any resulting alteration or damage to the wall paintings and sculpture. Any damage or deterioration to the wall paintings due to visitation is irreversible and unacceptable. Determining a safe number of visitors to the caves and the conditions of visitation lies at the core of the carrying capacity study.

Maximum number of people who can be accommodated in the Visitor Use Zone without unacceptable change or intrusion to the landscape and setting of the site. The desert landscape setting of the grottoes includes the natural environment (mountains, sand dunes, trees, river) as well as cultural features (stupas, historic buildings, the cliff face with caves) (see figs. 1, 2), all of which contribute significantly to the values of the site and are integral to the experience of the visitor. The landscape and setting are affected mainly by visual intrusions (buildings and parking lots) related to visitor services, and there is a direct relationship between visitor numbers and the buildings needed to service them.

Maximum number of people who can use the site daily while maintaining the quality of the visitor experience, visitor safety, and the ability of management to effectively meet visitor requirements. The relationship of visitors to the primary cultural and natural values, to the staff, and to the information and services provided constitutes the visitor experience of the site. A temporary decline in visitor satisfaction may be tolerated because the condition is reversible with good management and adjustment of visitor numbers; however, there can be no tolerance for diminished visitor safety.

In sum, the carrying capacity for the Mogao Grottoes is the maximum number of visitors who can use the site daily over the six-month peak visitation period of May through October without risk of damage to the wall paintings and sculpture, without unacceptable change to the setting and natural environment, and while ensuring visitor safety and satisfaction. Establishing the carrying capacity for the Grotto Zone is the priority, as it constitutes the primary cultural resource and is the focus of this study. The capacity of the Visitor Use Zone is part of an ongoing comprehensive plan for visitor services, including a visitor center and exhibition spaces, being undertaken by the Dunhuang Academy.

Methodology of the Carrying Capacity Study

The methodology developed for this study is adapted from the Visitor Experience and Resource Protection (VERP) model developed by the U.S. National Park Service for natural sites.⁴ It consists of two main stages, which are presented in the remainder of this paper.

Stage 1: Assessment and Analysis

The first stage of the methodology is assessment and analysis, which includes five distinct steps that progress from defining the problem to determining the conditions that will limit visitation. In the discussion that follows, the emphasis is on the research and assessment strategy in step 4.

1. *Identifying issues that have an impact on the site and visitors.* The most critical issue impacting the preservation of the wall paintings is active or ongoing deterioration. By this is meant that the mechanisms leading to decay are active or can be activated under certain conditions, one of which is elevated humidity, caused by the cave doors being open for visitation, allowing outside air to enter (fig. 3). For visitors, key issues to consider are acceptable carbon dioxide (CO₂) levels and comfortable physical space requirements.
2. *Identifying key indicators to monitor change.* Indicators measure the status or “health” of the resource. For the wall paintings, the main indicator of ongoing problems is evidence of hygroscopic salt-related deterioration (see fig. 3, right), but any detectable change in the wall paintings is indicative of undesired conditions and requires a management response. For visitors, the main indicators are a decline in satisfaction, as measured in surveys repeated over time, complaints to guides about crowding, and incidents of fainting due to bad air quality and high CO₂ levels.
3. *Defining desired conditions.* The desired condition for the wall paintings is stability, meaning no change in their current state. This requires a stable environment that does not activate the mechanisms of deterioration, namely deliquescent salts, and prevention of physical damage by visitors. For visitor safety and comfort, CO₂ concentrations must be maintained at or below internationally accepted levels, and the allocated space per person for visita-

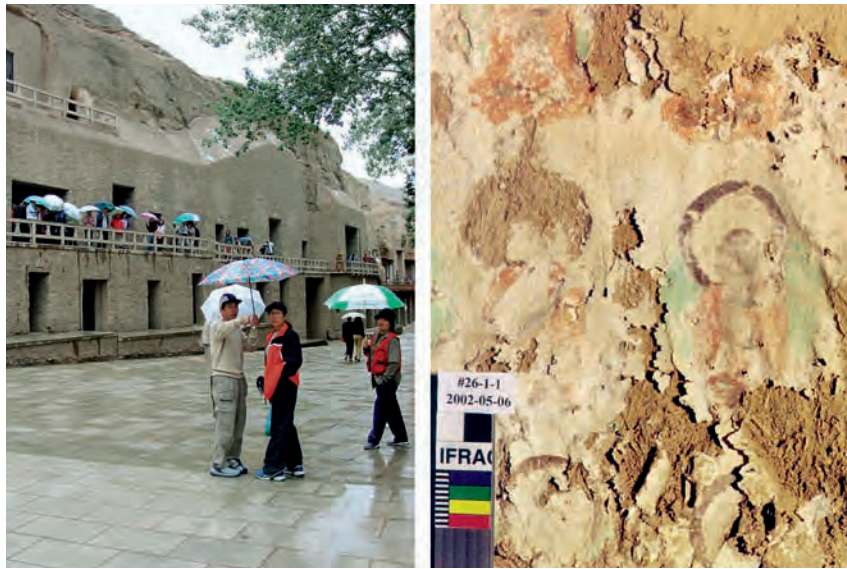

FIGURE 3 Ongoing deterioration of the wall paintings (a severe example, right) can be activated by elevated external humidity entering the caves, especially during periodic rain events in the summer months (left). Photos: J. Paul Getty Trust

tion should be sufficient to ensure that crowding is not a factor.

4. *Designing and implementing a research and assessment strategy.* The aim of the research and assessment strategy was to determine the mechanisms of deterioration, the link between deterioration and visitation, and the safety and comfort levels for visitors. This is the largest and most complex component of the carrying capacity study. The research strategy integrates analytical investigations in the laboratory, environmental monitoring and research, deterioration monitoring, assessment of condition and visitation potential for each cave, and visitor-related research and surveys. Together, these components of the study provide information on the following:

- the presence, types, and distribution of active deterioration in the caves;
- the conditions for activating this deterioration;
- the role of natural (i.e., not mechanically driven) air exchange with the outside, as measured by number of air changes per hour (ACH), in accelerating or mitigating deterioration, rise of relative humidity (RH), and CO₂ buildup; and
- the basis for determining risk to the wall paintings from visitation, to visitors themselves from CO₂ buildup, and to the visitor experience from crowding and other factors.

The six basic components of the research and assessment strategy are described in some detail below. These are the basis for determining the limiting conditions.

Analytical investigations. It was confirmed from the joint DA-GCI project in cave 85 that ongoing deterioration in the wall paintings is due mainly to hygroscopic salts and their response to fluctuations in humidity (i.e., deliquescence of salts as humidity rises and recrystallization as it falls).⁵ This cycle of deliquescence-recrystallization occurs repeatedly over time as cave humidity changes and ultimately results in damage to the wall paintings. To understand this phenomenon, it was necessary to identify the salt species and the deliquescent relative humidity. Laboratory investigations showed that Mogao salts, primarily sodium chloride (NaCl) with minor amounts of other salt species, begin to absorb detectable amounts of water vapor at approximately 67 percent RH (pure NaCl deliquesces at 75% RH) (fig. 4). Practically, this means that 67 percent RH is the critical point at which deterioration is activated in susceptible caves, though time is also important: the longer cave RH remains above 67 percent, the more moisture is absorbed (depending on the amount of salts) and the greater the potential for damage. For purposes of managing the caves, the RH threshold for visitation has been conservatively set at 62 percent.

Salt concentrations in caves vary and thus have different rate responses to fluctuating RH. To understand the effect of salt concentration and the progression of deterioration, painted clay coupons that simulate the structure, composition, and pigments of the wall paintings and loaded with different

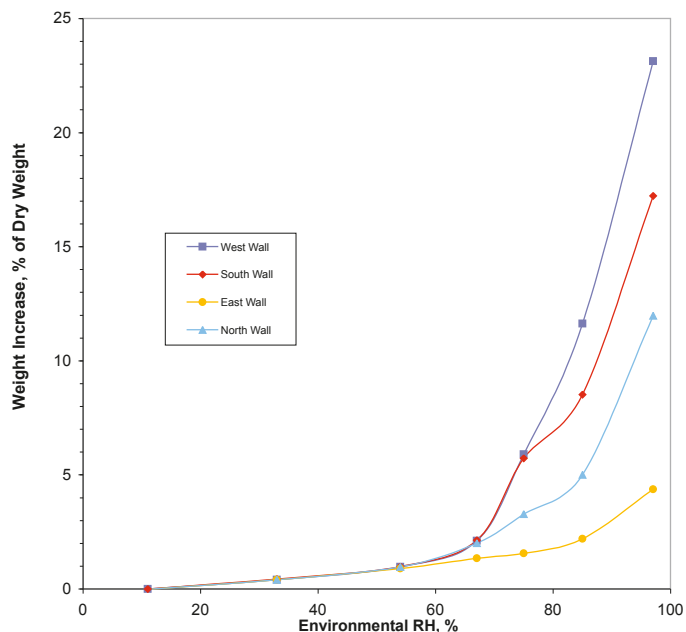

FIGURE 4 Laboratory investigations showed that salts identified in the wall plaster at Mogao (in this example, from cave 98) begin to absorb a large amount of water vapor at approximately 67 percent RH; note that the west wall—adjacent to the body of the rock—contains the highest percentage of salts in most caves and thus the quickest uptake of moisture.

amounts of salts were manufactured. Half of each coupon was also sprayed with a 2 percent solution of polyvinyl acetate (PVAC), previously used at Mogao as a treatment for flaking wall paintings. Once complete, the coupons were subjected to cycling at 25 and 85 percent RH in an environmental chamber to ensure thorough deliquescence and crystallization of the salts during each cycle. Coupons were examined after each drying cycle, that is, when recrystallization and any resulting damage occur (fig. 5), and changes were recorded photographically and through written description. Coupons representative of progressive deterioration were withdrawn and stored in a desiccator at a low RH to prevent further change.

An index of deterioration was then established that correlated with number of cycles and percentage of salt. The coupons that make up this index serve as a model for the development of salt-related deterioration in painted clay and exhibit many of the same patterns and types of conditions present in the wall paintings (e.g., cracking, flaking, plaster powdering). The coupons will also serve as reference for uncycled coupons placed in the caves as long-term deterioration monitors, as discussed in Deterioration Monitoring below.

Environmental research and modeling. Environmental monitoring is pivotal to making the link between visitation and mechanisms of deterioration in the caves. The objective is to determine the separate effects on the cave microenvironments of visitors (i.e., people in the caves) on the one hand and visitation (i.e., the opening and closing of cave doors) on the other, building on previous environmental monitoring and testing.

Since 1991, environmental monitoring has involved

- monitoring of the exterior climate (using a weather station established on top of the cliff in 1991 and temperature and relative humidity sensors placed outside the caves);
- installation of sensors recording air temperature, relative humidity, and surface temperature in four test caves, including visitor counters in the two open test caves;
- experiments to understand the effect of visitors on the microenvironment using varying-size groups occupying a cave for different periods of time;⁶
- experiments to determine the air exchange rate under varying conditions: doors opened, closed; visited, not visited; and the time required for the cave microenvironment to return to baseline; and
- spot monitoring in selected caves of CO₂, RH, and temperature during periods of peak visitation.



FIGURE 5 Clay coupon, simulating the structure, composition, and pigments of the wall paintings, showing typical salt-related deterioration after 26 cycles of high and low RH fluctuations in an environmental chamber. Photo: J. Paul Getty Trust

The air change rate, or ACH, is the number of times in one hour that the interior air is mixed with an equal volume of exterior air. Air change rate is measured by decay of a tracer gas released in the cave. There is no single, fixed value for a cave's ACH. The range of ACH values found for a particular cave depends on whether the doors are opened or closed, on the temperature difference between exterior and interior, on exterior wind speed and direction, and on cave characteristics such as size, architectural configuration, and area of door opening. ACH values drop markedly when cave doors are closed or when visitors block the entryway.

Air exchange with the exterior purges the cave of water vapor and CO₂ emitted by visitors and, likewise, may bring in high humidity from outside until the exchange process equilibrates interior and outside air. A continuously visited cave has its doors open throughout the visitation day (an eight-hour period) such that a return to the cave's environmental baseline (i.e., the situation without visitation and the door closed) is possible only during the closed period at night (sixteen hours). During the summer period, the external atmospheric humidity rises and experiences periodic spikes due to rain events (e.g., see fig. 3), typically reaching 85 percent. Elevated relative humidity may persist for several days depending on the duration of the rain and humid conditions, resulting in greater quantity of moisture absorbed by the salts and, consequently, greater damage upon drying.⁷ The surface temperature of the cave walls, always substantially cooler than exterior air in summer, is also integral to determining the relative humidity at the surface of the paintings and the potential for salt deliquescence. As air temperature cools at the wall surface, relative humidity rises, meaning that exterior air does not need excessive humidity to create undesired conditions for the paintings.

Caves with high air exchange may be expected to override the influence of visitors on relative humidity (approximately 5%) and CO₂ buildup. However, in caves where air exchange is low, the increase in relative humidity and CO₂ can be significant during peak months. The lowest ACH values, either measured in situ or calculated from an empirical formula (based on measured ACH values as a function of cave volume and similar measured caves), are used to determine the potential for elevated CO₂ levels in each cave. Statistical values based on environmen-

tal data collected over a number of years indicate how many days per month over the summer period those caves with active deterioration will likely require closure because of infiltrating high ambient humidity. Table 1 illustrates that on the average over the monitored five-and-a-half-year period, 68 percent RH was exceeded less than 5 percent (36 hours) of the month of July; however, in any single year a relative humidity higher than 68 percent can occur for a longer period as the climate varies from year to year.

Deterioration monitoring. Methods of monitoring for visitor-induced deterioration were established and put in place in four environmentally monitored test caves in 2002. Areas of active deterioration are monitored photographically (e.g., fig. 3), through written observations, and by collection and weighing of fine particles of plaster and, rarely, paint flakes fallen from the walls. Two of these caves were closed to visitation as control caves, and two were subject to routine visitation, allowing for comparison in the rate of change of unvisited and visited caves.

Salt-laden clay coupons identical to those cycled in the lab were installed in the caves to determine their feasibility for use as long-term deterioration monitoring tools. If and when the coupons show signs of deterioration, they will be compared to the reference deterioration index produced in the lab and assigned a rank of severity. The coupons are intended to supplement in situ inspection and provide standardized monitors for deterioration, over the long term, in susceptible caves.

Visitor management research and assessment. Visitor-related research and assessment have focused on three areas: visitor behavior and satisfaction; appropriate physical capacity or occupancy (for the usable area of the main chamber of each open cave) (fig. 6) and CO₂ safety levels; and current visitor management policies and capacity.

Table 1 Summer Monthly Percentile Rank of Surface Relative Humidity at the West Wall of Cave 29 Based on Data Collected over a Five-and-a-Half-Year Period

Month	7.2 Hours per Month RH Exceeded	36 Hours per Month RH Exceeded	72 Hours per Month RH Exceeded
May	56%	43%	35%
June	83%	55%	43%
July	84%	68%	59%
August	81%	62%	52%
September	60%	47%	35%



FIGURE 6 The physical capacity of a cave, based on usable area of the main chamber, varies markedly, with many caves being too small to handle a group of twenty-five persons. Inevitably, groups tend to cluster close to the guides and the main focal points. Photo: Richard Ross © J. Paul Getty Trust

Since 2002 visitor surveys and observations have been conducted by the Dunhuang Academy and the Australian Department of the Environment and Heritage to assess visitor behavior and satisfaction.⁸ Poor air quality and high CO₂ have long been a source of discomfort for visitors in the summer months. Acceptable limits for physical capacity (2 persons per square meter) and CO₂ levels (not to exceed 1,500 parts per million [ppm]) were established based on bibliographic research and industry standards.⁹ These values become critical parameters for defining the limiting conditions (see below and table 2).

“Management capacity” refers to the ability of management to protect the caves and to service the visitors in the Grotto Zone; it is premised on existing policies, practices, and capabilities of management. While there are many management issues that affect the carrying capacity of the site (e.g., water resources, visitor service facilities, parking capacity), the principal policies and practices that have an impact on the visitor capacity of the Grotto Zone are those related to guiding, tour reservations, the number of qualified guides and their language capabilities, duration of visits, and routing pattern of groups along elevated, narrow walkways (see fig. 2).

Table 2 Summary of Limiting Conditions and Implications for Visitation

	Limiting Condition	Implications for Visitation
“Winnowing” Conditions	Significance	Only caves of significance rankings A (Highest) and B (High) are considered acceptable for visitation by the Dunhuang Academy.
	Safety and access	Only caves with no safety risks or access restrictions are acceptable for visitation.
	Physical capacity	Only caves that have a minimum physical capacity of 25 persons (the maximum allowable group size) are amenable to visitation.
	Unacceptable risk	Caves assessed as being at an unacceptable risk from visitation cannot be opened.
Restricting Conditions	CO ₂ capacity	The CO ₂ capacity may limit the number of visits per day for caves with low ACH. The method developed allows for a preset number of visits per hour based on projections of CO ₂ (not to exceed 1,500 ppm) using ACH rates for caves with door left open. The resulting value is expressed as number of tours per hour @ 25 persons per tour that a cave can handle.
	Risk to wall paintings from humidity	High-risk caves are susceptible to deterioration from influx of humid air. A key limiting condition will thus be periods of high humidity outside (e.g., summer months, when ambient RH rises and rain events occur). This will require closing vulnerable caves during high humidity and monitoring for signs of change. It will not, however, have a great effect on daily carrying capacity if suitable “replacement” caves are identified for substitution when conditions require closure.
	Management capacity	The number of visitors who can be handled by management in the Grotto Zone is limited by guides available, tour group size, number of tours per guide, number of caves per tour, hours of opening, duration of cave visit, and routing constraints on the walkways of the grotto cliff face.

Assessment of cave physical condition and visitation potential. An assessment of physical condition and visitation potential is being undertaken for each of the 492 painted caves at Mogao. The principal objective is to determine which caves may be opened to visitation as a function of their physical condition (assessment of risk level to the wall paintings from visitation) and visitation potential (cultural significance, safety and access, physical capacity, and capacity set by the CO₂ limit). The CO₂ capacity of a cave is defined (for purposes of this study) as the number of visits of twenty-five persons that the cave can accommodate such that the CO₂ concentration does not exceed 1,500 ppm. In addition, the assessment will serve to plan for regular monitoring of the caves and periodic reevaluation of risk status.

A principal purpose of the risk assessment is to determine those caves that are at risk from visitation due to the salt-related mechanisms of deterioration. Those caves require careful monitoring and temporary closure under certain exterior environmental conditions. Other risks from visitation include the potential impact of humidity fluctuations or air movement on fragile paint layers (e.g., severe flaking) and mechanical damage from visitors touching the paintings. The risk assessment is used to establish a provisional carrying capacity and is the first stage in a process to ensure that there is no present or future impact from visitation. The preliminary ranking of risk will need to be confirmed and periodically reassessed as part of an ongoing monitoring program. The assessment process will result in a “portfolio” for each cave comprising a compilation of information on the date, location, size, dimensions, significance, visitation history, safety issues, and previous interventions, in addition to a record of its current physical condition. This information will become part of an integrated management system for both visitor management and conservation planning to be defined in Stage 2 of the carrying capacity study.

Defining the limiting conditions: The limiting conditions are the parameters that will restrict visitation to each cave and that may require management responses. They are derived from the research and assessment strategy discussed above and may be characterized as either “winnowing” or “restricting” conditions. The winnowers—principally significance, safety and access, and physical capacity but also including an unacceptable level of risk to the wall paintings—provide clear thresholds that must be met for caves to be open to visitors for purposes of establishing the initial

carrying capacity. These conditions thus winnow, or separate out, the caves currently suitable for visitation from those that cannot be visited.

The restricting conditions, which are applied to the winnowed caves, are risk to wall paintings, CO₂ capacity, and management capacity. Risk to wall paintings and CO₂ capacity will restrict visitation in certain caves under specific conditions but will not prevent their use. Management capacity, limited by factors such as tour group size, number of guides, and hours of opening will also play a role in restricting the total number of visitors that can be accommodated in a single day.

All of these limiting conditions are potentially amenable to mitigation strategies, which might allow a higher threshold of visitation. Some of these strategies may be viable in the short term (e.g., the use of smaller tour group size to allow for visitation of smaller caves), but others may require a period of investigation, testing, and monitoring to determine their efficacy (e.g., the use of fans to increase air exchange, which may create new risks, or undertaking conservation of caves at unacceptable risk). The limiting conditions and their implications for visitation are summarized in table 2.

Stage 2: Response

In the response stage of the methodology the limiting conditions described above are used to establish the carrying capacity of the grottoes. Each open cave will have a maximum number of possible tour groups per hour, based on the CO₂ limit and natural air change rates. For a number of reasons, forced air exchange is not considered practicable or desirable. These numbers will be adjusted further due to periodic climatic events (e.g., rain), requiring open caves at risk to be temporarily closed. The carrying capacity of the Grotto Zone will therefore vary as a consequence of management responses to environmental changes or a change in visitor management capacities and policies (e.g., size of groups, opening hours, or number of guides).

Long-term monitoring and management tools are needed for sustainable visitor capacity. Ongoing monitoring of the wall paintings and cave microenvironments will be necessary to determine if and when change occurs. Methods of monitoring that will trigger management responses, such as real-time data capture and display of the environment within selected caves, are in development by the Dunhuang Academy. In addition to such sophisticated monitoring, simple tools are being tested for use. For instance, small paper

sachets of different dry deliquescent salts (NaBr at 59%, KI at 70%, and NaCl at 75% RH) mixed with water-soluble dyestuff (crystal violet) have proved effective as a relative humidity indicator. Placed inside a cave, these “sentinels” indicate, by staining the paper, that a particular relative humidity has occurred or has been exceeded. Portable CO₂ readers are also being utilized for spot measurement of CO₂ in selected caves. Condition monitoring, based on the risk assessment and assigned risk level, is designed to provide evidence of ongoing deterioration or damage. When the monitoring indicates change from desired conditions, specific actions need to be defined and set in motion. This will mean closing those caves with active salt-induced deterioration when exterior humidity rises above 62 percent, or reducing the number of daily tours or the period between visits (while keeping doors open to allow natural ventilation to flush the cave) if CO₂ limits are exceeded, or reassigning risk level if deterioration is shown to be continuing.

Concluding Remarks

The correlation and interpretation of all the generated data and observations are complex and represent a long-term effort to develop a comprehensive and rational visitor capacity for the open caves over the summer period of high visitation to the site. The initial carrying capacity for the Grotto Zone will need to be validated over time and adjusted as necessary. Management systems will need to be developed that will be responsive to changing conditions, on a daily basis, and staff trained to ensure the upkeep and efficient running of these systems. The Dunhuang Academy has already put some of these systems in place, such as a reservation system, which is critical for managing visitors to the site. Others are in development, such as a visitor flow simulation model, which will determine the most effective way to move visitors through the site,¹⁰ and an off-site visitor orientation center, which will reduce the visual intrusions on the landscape, provide visitors with an introduction to the grottoes, and manage the flow of visitors to the site.

The strength of the carrying capacity study for the Grotto Zone is that it provides an objective, scientific basis for understanding and assessing the impact of visitation on the cultural resource at Mogao—the wall paintings. The difficulty of relating visitor use to impacts has been cited as the primary challenge to applying carrying capacity planning to cultural resources, as distinct from impacts to natural resources, which can be quantified (Valliere and Manning

2003: 237). Although we cannot yet quantify the impact of visitation on the wall paintings, we can use the theoretical model of deterioration to mitigate or prevent it. Continued research and monitoring will be needed to validate and refine our understanding of the causes of deterioration and their relationship to visitor use.

Like a living ecosystem, carrying capacity is an outcome of a complex system of relationships that function as an integrated unit. The carrying capacity study for the Grotto Zone described here is one essential component of that system that has as its central aim the preservation of the wall paintings for posterity rather than for the sole benefit of the present generation. The carrying capacity will not be sustainable, or effective, however, without constant vigilance and careful integration into the larger system of visitor management for the site.

Notes

- 1 For details of visitation, see Altenburg et al., this volume.
- 2 The *Principles for the Conservation of Heritage Sites in China*, developed through a collaboration between China's State Administration of Cultural Heritage, the Getty Conservation Institute, and the Australian Heritage Council, were issued by China ICOMOS in 2000. Available at www.getty.edu/conservation/publications/pdf_publications/china_prin_1chinese.pdf and www.getty.edu/conservation/publications/pdf_publications/china_prin_2english.pdf. See also Agnew et al. 2006 for application of the China Principles through the master planning process at the Mogao Grottoes and the Imperial Mountain Resort at Chengde.
- 3 Buddha's birthday, which takes place on the eighth day of the fourth month of the Chinese lunar calendar (usually in May), is also a time of excessive visitation but mainly involving people from the local community, who use the setting of the site for picnics and visit only a few selected caves.
- 4 Many examples of the methodology and application of VERP can be found on the Web. See, e.g., VERP 1997; Merced River Plan 2000.
- 5 The cave 85 project, a joint undertaking of the Dunhuang Academy and the Getty Conservation Institute, is described in numerous papers in this volume.
- 6 See Maekawa 1996 for early experimentation of the effect of visitation on the microenvironment.
- 7 This was demonstrated in cave 85 (see Maekawa et al., this volume).
- 8 See Li Ping et al., this volume.

- 9 Perceptions of crowding (encroachment on personal space) vary among cultural groups, with generally lower tolerance among Western tourists and higher tolerance among Asian visitors (for a discussion of crowding and analysis at the Glowworm cave site in New Zealand, see Doorne 2000). Visitor surveys at Mogao have shown that complaints about overcrowding during peak periods coincide with a general decline in satisfaction (see Li Ping et al., this volume).

CO₂ occurs as a component of the atmosphere, where its concentration is around 340 ppm. High levels in confined spaces are injurious to health. There are two aspects of CO₂ concentration relevant to Mogao visitation. Foremost is the comfort and safety limit. Industry standards for CO₂ are determined for commercial facilities and do not exist for exotic places such as caves; standards also vary among regions of the world, with European standards, for instance, being similar to or higher than U.S. standards (1,000 ppm), and are based on continuous exposure (ASHRAE 2007). In certain caves at Mogao, CO₂ levels frequently exceed 3,000 ppm in peak periods. Since visits are 5 to 8 minutes per cave and do not involve continuous exposure to the cave environment, the CO₂ limit has been set at 1,500 ppm.

The second equally important aspect is CO₂ as an air quality indicator. Heat stress on visitors, physical exertion, dehydration, and body odors combine with high CO₂ to result in degradation of visitor experience and instances of fainting, particularly among elderly or unfit visitors.

- 10 The Visitor Flow Simulation Model is being developed under contract to the Dunhuang Academy by Kiran Consulting Group, San Diego.

References

- Agnew, N., K. Altenburg, M. Demas, and S. Sullivan. 2006. Tourism: A good servant, but a bad master: Strategies for visitor management at Chengde and Mogao, China. *Historic Environment* 19 (2): 13–19.
- ASHRAE. 2007. *American National Standard Institute (ANSI)/ American Society of Heating, Refrigerating, and Air-Conditioning Engineers (ASHRAE) Standard 62, 1-2007, Ventilation for Acceptable Indoor Air Quality*. Atlanta, GA: American Society of Heating, Refrigerating, and Air-Conditioning Engineers.
- Doorne, S. 2000. Caves, cultures and crowds: Carrying capacity meets consumer sovereignty. *Journal of Sustainable Tourism* 8 (2): 116–30.
- Maekawa, S. 1996. Preventive strategies for reducing the impact of visitors on the microenvironments of caves at the Mogao Grottoes. In *Archaeological Conservation and Its Consequences: Preprints of the Contributions to the Copenhagen Congress, 26–30 August 1996*, ed. A. Roy and P. Smith, 76–79. London: International Institute for Conservation of Historic and Artistic Works (IIC).
- Merced River Plan. 2000. Yosemite National Park. www.nps.gov/archive/YOSE/planning/mrp/2000/final_mpr/html/mrpverp.htm.
- Valliere, W., and R. Manning. 2003. Applying the Visitor Experience and Resource Protection (VERP) framework to cultural resources in the national parks. In *Proceedings of the 2002 Northeastern Recreation Research Symposium*, ed. and comp. R. Schuster, 234–38. Gen. Tech. Rep. NE-302. Newtown Square, PA: U.S. Department of Agriculture, Forest Service, Northeastern Research Station.
- VERP. 1997. *The Visitor Experience and Resource Protection (VERP) Framework: A Handbook for Planners and Managers*. Washington, DC: U.S. Department of the Interior. National Park Service. <http://planning.nps.gov/document/verphandbook.pdf>.

Social and Environmental Monitoring as a Tool for Managing Visitor Impact at Jenolan Caves, Australia

Richard Mackay

Abstract: *The Jenolan Caves Reserve is a karst (limestone) landform within Australia's Greater Blue Mountains World Heritage Area. The reserve was set aside for the preservation of the caves in the 1860s—before the establishment of the world's first national park (Yellowstone, 1872). Of the 350 caves known in this ancient landform, sixteen are developed and open for public use, providing a major tourist destination and income for the reserve management. The reserve contains outstanding natural landforms and a fragile ecosystem that includes rare and endangered flora and fauna, as well as a rich cultural heritage comprising both indigenous sites and postcolonial structures with associative values related to the historic development of the caves for tourism.*

As part of the process for evaluating future management scenarios under increased visitation loads, the Jenolan Caves Reserve Trust (a management agency appointed by the government) commissioned a carrying capacity study in 1995. No finite carrying capacity was determined; instead, the study identified a complex interrelationship among visitor behavior, site management, and physical and biological impacts. Arising from this study, the trust put in place a social and environmental monitoring system that remains at the heart of conservation management for the reserve and forms a basis for balancing tourism pressures with conservation needs. This monitoring system examines a range of geophysical, biological, and social-experiential conditions. It seeks to determine relevant environmental and social factors, desired conditions, indicators to be monitored, methods for monitoring the indicators, causes of problems, priority of causal effects, and appropriate management responses. This paper showcases a small selection of the monitoring programs to illustrate how indicators and causal relationships with visitation are determined.

The Jenolan Caves Reserve encompasses a limestone valley studded with a system of caves set within a broader, dramatic, and heavily dissected sandstone plateau. The cave system includes more than 45 kilometers of known passageways, which are divided into 350 separately identified caves. Of these, sixteen caves are developed and open for public use. The 2,422-hectare (24 km²) reserve is within Australia's Greater Blue Mountains World Heritage Area. It is one of the country's outstanding tourist destinations, boasting a spectacular but fragile natural environment and a rich cultural heritage. In the 1860s—before the establishment of the world's first national park, Yellowstone, designated in 1872—the Jenolan Caves Reserve was set aside for the preservation of its caves, nine of which are currently open to tourists. The reserve is located in eastern Australia, in New South Wales, approximately 200 kilometers west of Sydney.

The Jenolan Caves Reserve Trust, the management body responsible for the reserve, was established in 1989, following previous management by state agencies responsible for railways, tourism, and Crown lands. The trust's statutory role is to conserve Jenolan Caves and promote them as a leading tourist destination in a manner that is environmentally, culturally, and commercially sustainable.

The reserve contains outstanding natural limestone (karst) landforms and a fragile ecosystem that includes rare and endangered flora and fauna, as well as a rich cultural heritage comprising both indigenous sites and late-nineteenth- and early-twentieth-century historical structures with associative values related to the historic development of the caves for tourism. Visitors to the cave system are predominantly day trippers—a mix of inbound international visitors and residents of the greater Sydney area. Current



FIGURE 1 The Grand Arch, an outstanding karst formation at the Jenolan Caves Reserve, NSW, Australia.

visitation is around 250,000 visitors per year, although over the past decade, the number has reached almost 300,000. On busy days, visitation results in excessive pedestrian and vehicular congestion within the confined Jenolan valley.

The cave system is at the bottom of a narrow valley, and the main access road passes through the Grand Arch, a large, partially collapsed cave that is one of the major visual icons of the reserve (fig. 1).¹ In 1989 the management plan for the reserve identified the impact of vehicles on both visitor enjoyment of the caves and physical damage to the Grand Arch and the caves' ecosystem, perceiving that the nexus between transport, environment, and visitor numbers was the critical issue for effective natural and cultural heritage management.

The analysis of the situation at Jenolan Caves and the remedial approach adopted in the 1989 management plan fit well with the model recently espoused by the World Tourism Organization in its *Tourism Congestion Management at Natural and Cultural Sites: A Guidebook* (World Tourism Organization 2004: 4–5), prepared in conjunction with ICOMOS. The parameters of the situation at Jenolan Caves fall squarely within the guidebook's model,² in that both destination management (in particular, the process of arriving at this heritage site) and site management are recognized

as critical to achieving the dual objective of care for the resource and a high-quality visitor experience.

Carrying Capacity Study

In 1995, as part of its process for evaluating future management scenarios for the reserve under increased visitation loads resulting from alternative access arrangements, the Jenolan Caves Reserve Trust commissioned a carrying capacity study. The results of this study have had far-reaching ramifications for management of the site as both an important heritage place and a major tourism destination.

The study was undertaken with a grant from the Australian Commonwealth Department of Tourism under the Sites of National Tourism Significance Program. The study was carried out by Manidis Roberts Consultants and was launched in 1995 by the minister for the environment.

The initial study brief required the development of a framework for determining the carrying capacity of the reserve, including the caves system. The study process quickly identified the need for a more complex understanding of the resources and issues involved. Therefore, the objectives were modified, requiring the study team to

- develop a clear understanding of the social, environmental, and infrastructure issues that face Jenolan Caves Reserve;
- apply the Visitor Impact Management process as a framework for determining carrying capacity at Jenolan Caves Reserve; and
- use the Visitor Impact Management process to develop an ongoing monitoring program and relate this to the management of the Jenolan Caves Reserve (Mackay 1995: 224).

A critical element of the study process was a three-day interactive workshop held at Jenolan Caves, involving staff and both national and international experts in visitor and karst management.

No finite carrying capacity was determined for the reserve; instead, the study identified a complex interrelationship among visitor behavior, site management, and physical and biological impacts. Using the results of this study, the trust put in place a program for social and environmental monitoring that remains at the heart of conservation management for the reserve and forms a basis for balancing tourism pressures with conservation needs.

The study identified the following major issues relating to managing the environment at the Jenolan Caves Reserve:

- overall objectives for the reserve
 - conservation of the resource
 - high-quality visitor experiences
- resource management and research
 - use of science and research in decision making
 - need for baseline data
 - environmental monitoring
- visitors and visitor experience
 - recognition of interpretation and education as crucial elements of visitor experience
 - need for information (what do they want/what do they get?)
 - relating Jenolan Caves to visitors' spectrum of recreational experiences
- infrastructure and transport
 - pedestrian/vehicle conflict (especially in the Grand Arch area)
 - vehicle parking capacity (which currently determines maximum visitor numbers)
 - access limits
 - impacts of emissions, runoff, and so on
 - need for further research

Visitor Impact Management

Application of a rigid carrying capacity limit at the reserve was rejected because it may have resulted in the oversimplification of a complex issue. Instead, two existing approaches were adopted for managing areas with high resource values and visitor use: *The Limits of Acceptable Change (LAC) System for Wilderness Planning* (Stankey et al. 1985) and *Management Process for Visitor Activities* (Parks Canada 1985).

A major premise of these methodologies is that management goals, which are qualitative in nature, must be translated into measurable (quantitative) management objectives through the use of indicators and standards. Environmental goals are therefore achieved by employing standards that are monitored through the use of suitable indicators. Monitoring programs are now in place at Jenolan Caves for a range of geophysical, biological, and social/experiential conditions.

The management approach for Jenolan Caves seeks to determine the following:

- relevant environmental and social factors/issues
- desired conditions
- indicators to be monitored
- methods for monitoring the indicators
- causes of problems
- priority of cause and effect
- appropriate management responses

The range of issues addressed through this process is broad and includes environmental considerations, physical impacts, biology, occupational health and safety concerns, and the visitor experience. Given the time and resources used to accumulate baseline data, the monitoring system remains at a relatively early stage. Even so, outputs are now directly influencing management decisions.

Operation of the monitoring program is the day-to-day responsibility of expert staff, assisted by cave guides and maintenance staff. From time to time, aspects of the monitoring work are included in the visitor program. For example, if personnel or equipment are observable during cave tours, the tours may pause to allow for explanations of the monitoring process. In addition, to provide a theoretical framework and a link with academic institutions and other relevant expertise, the Jenolan Caves Reserve Trust appointed an advisory group—the Social and Environmental Monitoring Committee—that has guided the program since 1996. The results of this structure have been excellent and have included an impressive array of graduate and undergraduate research projects and academic publications.

Table 1 describes the various components of the Jenolan Caves Reserve Visitor Impact Monitoring System.

Examples of the Monitoring Process for Jenolan Caves

Space does not permit a comprehensive discussion of the full range of issues monitored at Jenolan Caves and the entirety of the social and environmental monitoring process. Instead, the following eight monitoring issues are outlined briefly below:

- air quality (carbon dioxide)
- hydrology
- cave desiccation and humidity
- trail quality
- lampen flora

Table 1 Implementation and Evaluation of the Jenolan Caves Reserve Visitor Impact Monitoring System (Adapted from Manidis Roberts Consultants 1995)

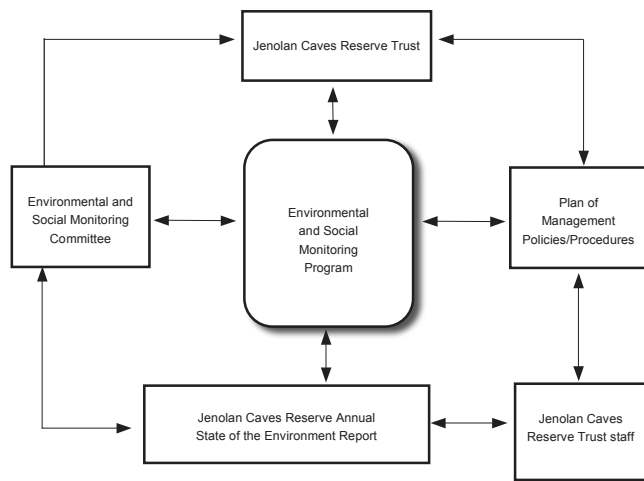

- dust, lint, hair, skin flakes
- radon
- visitor experience

Table 2 summarizes how the social and environmental monitoring program applies to these examples. The information has been adapted from an internal report on the initial years of operation (Thurgate and Hamilton-Smith 1999).

Air Quality (Carbon Dioxide)

Air quality is measured both above- and belowground with the aim of achieving atmospheric conditions that are normal for a particular area or cave. Indicators for high carbon dioxide levels are increases in parts per million (ppm) above background level but, more significantly, corrosion of calcium carbonate (i.e., cave formations) and/or visitor distress. Michie (1997: 215–16) suggests that surrogate measures such as the design intention for ventilation of buildings offer appropriate guidance for permissible levels of carbon dioxide, as the national occupational health and safety standards suggest levels for short-term exposure (15 minutes) that could result in serious visitor discomfort or distress. A general level of 1,000 ppm (0.1%) is recommended, although a very short exposure of up to 5,000 ppm (0.5%) is acknowledged as being possible.

Air quality is monitored with a Dräger apparatus to obtain in situ infrared grab sampling and continuous sam-

pling (fig. 2). These measurements are taken periodically and can be used to determine cave recovery times, that is, the time needed for the air quality in a particular area to return to a normal background level. Some of this information has been correlated with meteorological, microclimatic, and cave visitation data (e.g., Michie 1997: 181–215).

Periodically, carbon dioxide readings are significantly higher than normal in aboveground areas (no doubt, a result of high vehicle numbers). However, the current levels of pollution are relatively low, although concerns continue regarding the contribution of carbon dioxide to weathering of exposed limestone areas. Belowground the situation is more serious. Monitoring has established that the presence and frequency of visitors in the caves during the peak summer season raises the carbon dioxide levels such that they do not “relax” to the normal background level within the target time of twelve hours. While these levels are not currently a threat to visitor health, the desirability of ongoing monitoring in this area is self-evident.

Measuring of physical corrosion resulting from high levels of carbon dioxide will need to continue. The corrosion threshold appears to be site-specific, and active formations do not appear to be threatened (Thurgate and Hamilton-Smith 1999).

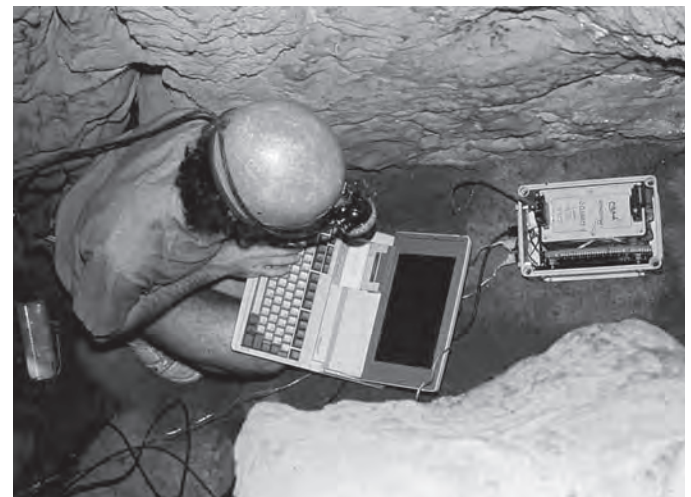

FIGURE 2 A scientist downloads information recorded during hydrological and water quality tests. Courtesy of Jenolan Caves Reserve Trust

Table 2 Monitoring Process at Jenolan Caves for Selected Social and Environmental Issues

Issue	Desired Condition	Indicators	Monitoring Methods	Causes of Problems	Priority	Management Response
Air quality (e.g., CO ₂)	Normal levels for cave based on adequate characterization study	Visitor discomfort (as observed by cave guides) CO ₂ levels above 1,000 ppm Corrosion of calcium carbonate	DRÄGER apparatus for in situ infrared grab sampling and continuous sampling to determine cave relaxation times; Meteorological and microclimate monitoring	Vehicles in Grand Arch and vicinity	High	Exclude vehicles from Grand Arch vicinity
				People	High	Monitor/modify visitation
				Microbial decay of organic material	Low	Reduce organic material
				Disruption of cave air-flow patterns	Low	
Hydrology – Physical – Chemical – Biological	Near-natural conditions	Increased peak flows; poor water quality; low biodiversity	Historical records; stream gauging; water quality studies; biological surveys	Introduction of hard surfaces (such as concrete paths)	High	Increase and diffuse recharge areas
				Vegetation changes	High	Revegetate catchment
				Channeling of traffic and people	High	Relocate some structures, i.e., parking lots; traffic and people management
Unnatural cave desiccation	Near-natural conditions; Presence of indicator organisms at baseline levels	Dust dryness; Change in composition or decline in fauna	Temperature, evaporation/humidity; Indicator organisms	Paved surfaces and drainage systems	High	Reestablish natural drainage
				Unnatural air exchange	High	Install doors in caves to stop unnatural air exchange
				Stream diversion	High	Manage tour frequency
Trail quality	High safety levels; constructed to standards as outlined in manuals; trails providing a diversity of experience	Quality of surface; signage; trail width; amount of vegetation disturbed	Visual assessment by trained staff; relevancy to desired experience	Poor construction	Medium	Development of plan, brochures, and interpretation for trails Close trails at times of adverse weather and high visitation
				Lack of maintenance; no policy for trails	Medium	
				Focus of staff and resources on high visitor use areas	Medium	
Lampen flora (algae, moss, ferns, etc.)	Minimal growth; low treatment rate; no permanent physical damage by roots	Rate of treatment	Detailed records of treatment for each site	Exposure to light; use of unclean wash water; infection through introduction of spores	High, if significant growth on cave deposits	Reduce exposure time to light; infection control; develop new control techniques; studies on long-term effects of lampen flora
Lint (primarily hair, skin, and other organic materials)	Minimal level	Visible dulling of formation	Lint collection stations; petrie dish collection	Visitors	High	Require overalls to be worn; cyclical cleaning; remove wire netting from edge of cave paths; consider electrostatic removal systems
Radon	No health and safety issues for guides	Direct measure of emission	Radon badges/meters	Radioactive gravel deposits	High	Limit guide hours underground to safe level (1,000 hours per year)
Quality of visitor experience	High rating of experience; people going away wanting more; range of experiences achieved	Frequency of return visits; experiences achieved; ratings of experience	Visitor interviews, surveys, observation; guide feedback	Group size	High	Develop comprehensive visitor services plan using appropriate research
				Condition of cave	High	
				Number of visitors in cave at one time	Medium	
				Quality of interpretation	High	
				Program design	High	
				Vehicles in Grand Arch	High	
				Pricing	Low	

Source: Manidis Roberts Consultants 1995



FIGURE 3 Freshwater cave fauna like this tiny shrimplike crustacean known as a syncarid are good indicators of environmental change. Courtesy of Jenolan Caves Reserve Trust

Hydrology

Hydrological issues are at the heart of the health of the caves system. The desired condition is near-natural water conditions. Impacts are indicated by unseasonable peak flows, decline in water quality, or specific impacts on aquatic flora and fauna.

In the initial phases of implementing the monitoring program at the reserve, emphasis was placed on the physicochemical properties of the water (depth, pH, conductivity, temperature). Since these results were inconclusive, monitoring of freshwater invertebrates was added to the program in connection with a statewide project (fig. 3). Fecal coliform bacteria and other indicators of pollutants are also measured.

The hydrological studies are encouraging and suggest that although there is some pollution in the Grand Arch vicinity, water quality is generally good. Fecal contamination is present but at levels low enough to meet relevant standards for recreational water quality (although not for drinking water). It is therefore clear that ongoing monitoring is a major priority and that close attention must continue to be paid to bacteriological surveys.

Cave Desiccation/Humidity

Of the 350 identified caves at Jenolan, 16 are developed and open for public use. Physical modifications to the cave system to facilitate mass tourism have altered airflow and humidity. Although the desired condition is a near-natural

state inside the cave system, the altered airflow and humidity and the introduction of particulates and vehicle emissions are unavoidably affecting what can be achieved.

Indicators monitored include particulates, dryness, and changes in the composition of flora or fauna. Over an extended period, weekly measures have been made of humidity, temperature, and evaporation, as well as particulate levels. The data indicate that metal-rich dust related to vehicle emissions is penetrating up to 50 meters inside some of the caves near the Grand Arch area and then is being disturbed and redistributed by visitors. The most obvious effect is increased dullness of some formations and consequent reduction in the visitors' aesthetic experience.

Data regarding the amount of water and humidity in the caves are gathered using some interesting techniques—including the attachment of rubber condoms to some formations (fig. 4). Desiccation and visitation frequency, rather than absolute visitor numbers, appear to be correlated. Management responses to desiccation include controlling the frequency of opening airtight doors that have been installed in the caves (fig. 5) rather than limiting the size of tour groups.



FIGURE 4 Rubber condoms are attached to some cave formations to measure the quantity of water entering the cave system. These data may be correlated with both external data (e.g., rainfall) and internal cave data (e.g., visitation numbers and frequency, desiccation). Courtesy of Jenolan Caves Reserve Trust



FIGURE 5 The opening and closing of airtight doors installed in the caves is used to stabilize humidity and manage desiccation. Courtesy of Jenolan Caves Reserve Trust

Trail Quality

The reserve features a network of scenic trails, many of which were constructed in the early twentieth century. The desired conditions for trails include high standards of safety, compliance with statutory controls, and a high-quality, diverse visitor experience. The impact on trail quality can be measured in a number of ways, including the quality of the surface and the amount of disturbance.

In view of the importance of trails to the total visitor experience at the reserve (not to mention obligations regarding public safety and potential liability), the trust has designed its own apparatus for measuring trail degradation and erosion using a “track profile comb” and photo monitoring (fig. 6).

This work reveals not only that the quality of some trails is substandard, but that trails are especially subject to erosion where they have existing soft substrate and during periods of wet weather and concurrent high visitation. These results are yet to be translated into management, but an obvious approach would be to consider closure of some susceptible trails after periods of inclement weather.

Lampen Flora

Lampen flora are algae, moss, ferns, and other plants that colonize new areas of the caves as a result of lighting introduced for visitation or management. The desired condition is



FIGURE 6 This specialized “track profile comb” was developed to measure and monitor trail degradation and erosion. Courtesy of Jenolan Caves Reserve Trust.

minimal flora growth in the first place, with minimal need for treatment or management, and, of course, no permanent physical damage to the cave formations.

Although the presence of lampen flora is a highly visible impact to the caves, relatively little work has been done to date either on indicators or on monitoring, although staff currently keep detailed records of treatment at each site. (Treatments include manual removal and careful use of herbicide.) A number of management actions are possible, including relocating lighting, using herbicides, or cleaning; however, the problem is not considered sufficiently profound to warrant an active management response at this stage.

Dust, Lint, Hair, Skin Flakes

Visitors introduce dust, lint, and other organic particulates such as skin flakes and hair to the cave system. These organic particulates, in turn, may be the source of additional food for cave microbes and new bacteria. The desired condition is a dust- and lint-free cave system with pristine formations (rather than the discolored or “fuzzy” formations visible in the more heavily visited areas), as well as near-natural bacterial activity.

The accumulation of dust and lint can be measured directly, as has occurred at Jenolan Caves over an extended period using strategically placed Petri dishes as part of a doctoral thesis project (Michie 1997). The collection points were

located in both visited and wild (off-limits) caves. The presence of the Petri dishes provided opportunities for guides to explain the monitoring processes to interested visitors.

Not surprisingly, dust and lint accumulation correlates with visitor numbers; it is a cumulative, ongoing problem at Jenolan Caves. Cleaning cave formations with low-pressure plain water is possible, but the additional workload is not desirable. Although cleaning produces an aesthetically pleasing result, it does not fully address the implied introduction of an artificial bacterial food supply.

Significantly, Michie's work indicates that the impact of lint fibers on the cave ecosystem has been overstated relative to the subtler but longer-term physical change wrought by the mineral content of dust. Michie (1997: 179) attributes this to the high visibility of the lint fiber.

The current management regime is, therefore, minimal, comprising strategic placing of regularly cleaned mats on some pathways and periodic cleaning of limestone formations with water. Supplying lint-free overalls to visitors to fragile areas has been suggested as another control strategy, but it has not been implemented. There has also been discussion (but not implementation) of introducing lint pickers (small specialized implements to remove lint) and/or electrostatic devices at the entrance to some cave areas.

Radon

Radon, a radioactive element, has been identified in low concentrations in some of the mineral deposits within the cave system. While radon is of minimal danger per se, high cumulative doses may present health problems. Based on an extensive 1994–95 survey of Australian tourist caves (Solomon et al. 1996) and on national occupational health and safety standards, an action level, that is, a maximum level above which action must be taken, has been determined for radon. There is also the risk that visitors will perceive a health threat (e.g., through word of mouth, possibly leading to adverse publicity) and stay away from the caves. The desired condition with respect to radon is obviously that there be no health or safety issues. Radon concentrations are directly measured in the cave system using simple CR-39 detectors (Solomon et al. 1996: 4).

The trust is mindful that prolonged exposure to high concentrations of radon and its radioactive decay products is linked to an increased risk of cancer (Jenolan Caves Reserve Trust 1997). However, it is abundantly clear from the data gathered to date that visitors are not exposed to radon for long enough periods for this to be a problem. Nevertheless,

radon exposure is an occupational health and safety issue for guides and other staff. The trust has therefore introduced a provisional policy that limits staff underground hours to a maximum of one thousand hours per year and requires routine monitoring of individual exposure with personal radon measuring devices.

Visitor Experience

Provision of an outstanding visitor experience to Jenolan Caves is one of the key statutory and corporate objectives of the trust. The caliber of visitor experience can be measured through a range of indicators, including visitor survey responses, the frequency of return visits, or observation of visitor behavior and the impact of crowding on people and services. A range of visitor surveys have been undertaken, including group discussions, personal interviews, and written surveys. External consultants, graduate students, and trust staff have conducted a number of observational activities, and there have been surveys of bus tour groups and independent travelers. The visitor surveys and monitoring conducted at the reserve are directly related to a range of other trust activities, including marketing and customer service.

Survey results suggest that visitors are generally satisfied with their experience but express dissatisfaction relating to crowding, access, and excessive time underground. It is clear that tour group size is a major issue. (Other visitor satisfaction issues arise from negative experiences with some of the accommodations and with food and beverage concessions operating at the reserve, but these are not addressed here.)

Results of monitoring visitor experiences at Jenolan Caves have been used by trust management in a number of ways, in particular, in the development of visitor services and interpretation plans.

Summary

The Jenolan Caves Reserve is one of Australia's great natural wonders, enhanced by a rich cultural history and a superb built environment. The challenge for managers of this extraordinary but increasingly popular attraction is to prevent it from being "loved to death." Implementation of the environmental and social monitoring program at Jenolan Caves is still in its infancy. The trust continues to allocate resources to gathering baseline data.

The Visitor Impact Management framework adopted by the trust provides a structured basis for dealing with

the potential for increased visitation while at the same time minimizing environmental impacts and enhancing visitor opportunities and experiences. The process enables the Jenolan Caves Reserve management to measure and understand the effects of actions on both visitors and the fragile ecosystem.

Acknowledgments

This paper and the process it summarizes represent the combined efforts of a dedicated consultant team from Manidis Roberts Consultants and their expert advisers, as well as the Jenolan Caves Reserve Trust Board and its committees and staff, in particular Ted Reedy and Andrew Fletcher, general managers; Ernst Holland and Mia Thurgate, karst resources managers; and Stephen Meehan, senior environmental manager. The study was funded by the Australian Commonwealth Department of Tourism under the Sites of National Tourism Significance Program. I am grateful to Felicity Watson for editorial assistance and to Sharon Sullivan of Sullivan Blazejowski and Associates, Australia, for presenting this paper on my behalf at the Second International Conference on the Conservation of Grotto Sites.

Notes

- 1 Concerns about the impact of this road on the karst ecosystem and the visitor experience led, in the mid-1990s, to consideration of alternative access arrangements that included aerial (cable car or gondola) proposals that would have relied on a major increase in visitors. Government officials have decided not to proceed with any of these proposals at this stage.
- 2 This model offers an integrated approach to congestion management that recognizes that the congestion of sites cannot be solved by site managers alone and that site managers require the active support of other key stakeholders, including local authorities and other private-sector services that provide infrastructure allowing transport to and from the site. Congestion is minimized through destination management and demand management, issues linked by the experience of the visitor through three stages of demand: choosing a destination and time to travel (Demand Management) and the subsequent journey to the destination; the destination (Destination Management); and the site (Site Management).

References

- Jenolan Caves Reserve Trust. 1997. State of the environment report. In *Jenolan Caves Reserve Trust Annual Report 1996/1997*. Bathurst, NSW: Jenolan Caves Reserve Trust.
- . 2003. *Jenolan Caves Reserve Trust Annual Report 2002/2003*. Bathurst, NSW: Jenolan Caves Reserve Trust. www.jenolancaves.org.au/.
- Mackay, R. 1995. Visitor impact management: Determining a social and environmental carrying capacity for Jenolan Caves. In *Ecotourism and Nature-Based Tourism: Taking the Next Step: Proceedings of the Ecotourism Association of Australia National Conference, 18–23 November 1995, Alice Springs, Northern Territory, Australia*, ed. H. Richins, J. Richardson, and A. Crabtree, 223–28. Alice Springs, NT: Ecotourism Association of Australia and the Commonwealth Department of Tourism.
- Manidis Roberts Consultants. 1995. Determining an environmental and social carrying capacity for Jenolan Caves Reserve: Applying a Visitor Impact Management System. Report prepared for Jenolan Caves Reserve Trust. Funded under the Commonwealth Department of Tourism, Sites of National Tourism Significance Program.
- Michie, N. A. 1997. An investigation of the climate, carbon dioxide and dust in Jenolan Caves, NSW. Ph.D. diss., Macquarie University. www.es.mq.edu.au/physgeog/research/theses/p_abs/michie_abs1.rtf.
- Parks Canada. 1985. *Management Process for Visitor Activities*. Ottawa: National Parks Directorate.
- Solomon, S. B., J. R. Pegg, R. Langroo, R. G. Lyons, and J. M. James. 1996. *Occupational Exposure to Radon in Australian Tourist Caves: An Australia-Wide Study of Radon Levels: Final Report of Worksafe Australia Research Grant (93/0436)*. Yallambie, Vic.: Australian Radiation Laboratory. <http://www.arpansa.gov.au/pubs/technicalreports/arl119tx.pdf>.
- Stankey, G. H., D. N. Cole, R. C. Lucas, M. E. Petersen, and S. S. Frissell. 1985. *The Limits of Acceptable Change (LAC) System for Wilderness Planning*. USDA Forest Service General Technical Report, no. INT-176. Ogden, UT: Intermountain Forest and Range Experiment Station, Forest Service, U.S. Dept. of Agriculture. www.fs.fed.us/r8/boone/documents/lac/lacsummary.pdf.
- Thurgate, M., and E. Hamilton-Smith. 1999. Table of social and environmental monitoring (SEM) achievements to December 1999. Unpublished report for Jenolan Caves Reserve Trust. Bathurst, NSW.
- World Tourism Organization. 2004. *Tourism Congestion Management at Natural and Cultural Sites: A Guidebook*. Madrid, Spain: World Tourism Organization.

PART FIVE

Scientific Research



Nature and Distribution of Cohesion Forces in Earthen Building Materials

Henri Van Damme, Mokhtar Zabat, Jean-Paul Laurent, Patrick Dudoignon, Anne Pantet, David Gélard, and Hugo Houben

Abstract: *Is there a certain type of interparticle force to which earth-based materials owe their cohesion and which has to be absolutely preserved in order to avoid deterioration? Considering the complex fabric of most earthen materials and the variety of conditions to which they are exposed, it is unlikely that there is one single type of dominant interaction for all types of earthen materials. It is much more likely that there are a number of forces, each of them dominant in given composition and hydration conditions. The collaborative study (GCI, CRATerre-EAG, ICCROM) discussed in this paper aims to provide a basic understanding of this, through a combination of experimental and modeling techniques. First, a review is presented of the main cohesive forces that have been identified in sand, clays, and Portland cement, pointing to the properties of the most universal among them: capillary forces and van der Waals forces. Second, an experimental study is presented of the cohesion of a model material made of a sand-kaolinite mixture, in which the cohesion is precisely expected to stem from capillary and van der Waals forces. This composition is representative of a wide range of earthen materials. The fabric of the samples was characterized by scanning electron microscopy and synchrotron radiation microtomography. Both techniques revealed sand grains surrounded and bridged by clay particles. Cohesion was measured by using classical soil mechanics techniques. Third, a model for the cohesion is proposed and compared with the experimental results, taking into account both the capillary forces and the van der Waals forces. The main conclusion is that water is an essential component of earth cohesion, even in clay-rich*

materials, and that finding the optimum water content is essential for successful conservation.

The deterioration of earthen cultural heritage, including wall paintings on earthen supports, is most often due to a loss of cohesion of the base material. This makes the understanding of the source of this cohesion an integral part of a rational conservation approach. What are the interparticle forces responsible for the cohesion of earthen walls, substrates, or plasters? Considering the extreme compositional variability of the raw materials used in earthen construction and artwork, ranging from sandy soils to lateritic crusts or almost pure clay deposits, it is unlikely that a single type of interaction dominates.

Earth is a highly heterogeneous material, with many different components interacting with each other and with interstitial fluids. Unlike that of metals or ceramics, the cohesion of earth is the result of a complex equilibrium between attractive, repulsive, and frictional interparticle forces that depend in a subtle way on the raw mineral composition, preparation method, water content, and atmospheric conditions. Yet knowledge of these forces and their dependency on environmental parameters is essential for successful conservation.

In this paper we report some results from a collaborative study that aims to provide a basic understanding of these forces, through a combination of experimental and modeling approaches applied to a simple model material representative of a wide range of earthen materials. This research was conducted within the framework of Project TERRA,¹ in coordination with research at the Getty Conservation Institute on

the interaction of water with earthen building materials and at ICCROM on the compositional and textural characterization of original materials from archaeological and historical earthen structures.

Cohesion and Interparticle Bonds

Before examining the different forces that may be operating in earthen materials, it is worth looking at the concept of cohesion itself. What is the difference between a 1-meter-high sand castle on a beach and a seven-story earthen building in Yemen? In terms of the mechanics of elementary granular materials going back to Coulomb in 1773, the difference is cohesion, C . Cohesion is the internal stress that, together with intergranular friction, prevents a granular material subject to a force (its own weight) from dividing in two, that is, sliding along a failure plane.

In its simplest form, the failure criterion (Nedderman 1992) for a dry, cohesionless sand heap is

$$\Delta P_{top} = 2\gamma_{sv} / \rho \quad (1)$$

where τ and σ are the shear and normal stresses on the sliding plane, respectively, and μ is the friction coefficient. This equation states that the top layer of a sand heap cannot withstand a stress along the slope larger than a fraction μ of the stress perpendicular to the slope (fig. 1a). A simple geometric argument shows that μ can also be expressed as $\tan\theta$, where θ is the maximum angle of stability. If attractive interparticle forces provide some cohesion to the material, a larger stability angle can be achieved (fig. 1b), and equation 1 becomes

$$\tau = \mu\sigma + C \quad (2)$$

The cohesion C has units of energy per unit of material volume. At the microscopic level, cohesion is the energy necessary to break all the interparticle bonds.

There are several ways to classify bonds between atoms, molecules, or mineral particles. One of them is to consider chemical forces, on the one hand, and physical forces, on the other. Chemical forces are quantum mechanical in nature. The very strong attractive force called the covalent bond, which stems from electrons being shared between atoms, is one such chemical force, operating at very short interatomic separations on the order of 0.1 or 0.2 nanometer. Molecules, like the water molecule, or solids, like quartz, graphite, or glass, owe their cohesion to covalent bonds.

Physical forces are much more diverse. They originate either from purely electrostatic interactions between electric charges of ions, or dipoles, or from polarization effects. They can be almost as strong as covalent forces, but most of them are weaker. They also operate over a much longer range, up to several nanometers. Physical forces are responsible for the cohesion of all living matter. Since they act between macroscopic bodies close to each other, physical forces are also called surface forces.

In the case of earthen materials, an extensive network of chemical (covalent) bonds between mineral particles is highly unlikely. Unlike for other porous materials, such as sandstone, brick, or porous glass, the interatomic chemical bonding continuity of earthen materials is very limited, if there is any. When earthen material is scrutinized on the microscopic level, it is interrupted almost everywhere by air voids or liquid water films in the *interparticle* space. The best demonstration of this is the swelling and loss of cohesion that is observed when earth is dispersed in water. Yet earthen materials are often able to withstand stresses of the same order of magnitude as a soft rock or a low-cement mortar.

FIGURE 1 In a noncohesive material (a) tilted at an angle θ , the top layer remains stable as long as the shear stress parallel to the slope, τ , does not exceed a fraction, $\mu = \tan\theta$, of the normal stress perpendicular to the slope, σ . If this limit is exceeded, an avalanche starts. The parameter is the intergranular friction coefficient. In a cohesive material (b), larger slopes are allowed, thanks to attractive intergranular forces. The extra shear stress is, by definition, the cohesion C of the material.

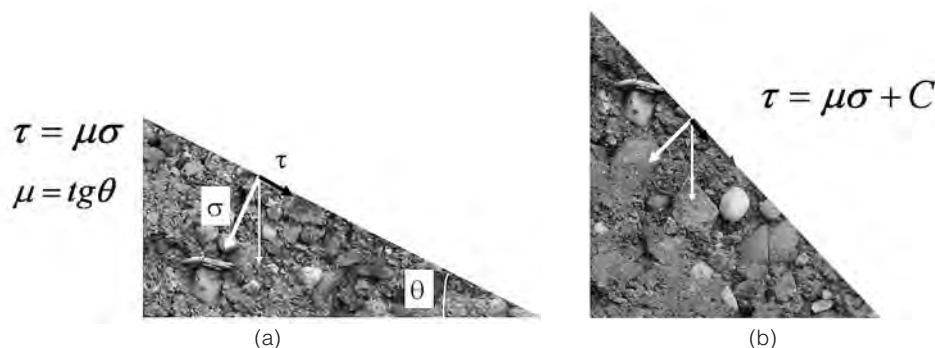

Capillary Cohesion: The Art of Building Sand Castles

In dry sand, cohesion is vanishingly small, and building even the smallest vertical wall with this material is virtually impossible. An avalanche starts and flows until the slope reaches the equilibrium angle determined by the friction coefficient. As soon as the air contains water vapor, some cohesion may be detected, due to microscopic liquid bridges between the grains. These bridges form by condensation of the vapor, well before the dew point temperature is reached, due to the attractive forces between the water molecules and the surface atoms of the sand grains. This is so-called capillary condensation (Adamson and Gast 1997). Then, building a vertical wall is still risky but feasible, up to moderate heights. The cohesion stems from the pressure difference between the pressure in the liquid in the bridge and that of the humid air outside (fig. 2). This pressure difference is called the Laplace pressure or capillary pressure, the negative curvature of the meniscus (the center of curvature is outside the liquid). This is a result of the pressure being less in the liquid than in the air, giving rise to a net attractive force.

The capillary pressure across the air/water meniscus is written as

$$\Delta P_{cap} = 2\gamma_{LV} / \rho \quad (3)$$

where γ_{LV} is the air/water surface tension and ρ the meniscus radius. Under equilibrium conditions, the meniscus radius is determined by the relative humidity (RH), via the Kelvin equation,

$$\ln RH = -\frac{\gamma_{LV} \bar{V}}{RT \rho} \quad (4)$$

where \bar{V} is the molar volume of water (18 cm³ per mole). So, if the relative humidity is known, the capillary or Laplace pressure is automatically determined. The larger the RH, the larger the meniscus radius in equilibrium with that RH; at 100 percent RH the meniscus radius is infinite, which means that the liquid surface is flat. Conversely, the lower the relative humidity, the smaller the meniscus radius and the larger the attractive pressure will be. For small meniscus radii, say, in the submicrometer range, the capillary pressure becomes considerable. For instance, in dry conditions at 30 percent RH, which corresponds to equilibrium meniscus

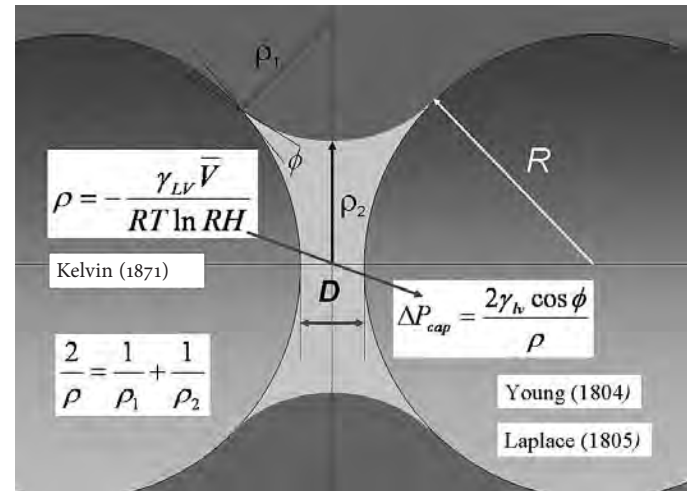

FIGURE 2 A liquid bridge between two particles is characterized by an average curvature radius ρ , which is directly related to the two principal curvature radii of the meniscus, and ρ_1 and ρ_2 . Kelvin established the conditions of capillary condensation, that is, the relationship between this average curvature radius and the relative humidity RH , whereas Young and Laplace established the relationship between the average curvature radius and the attractive pressure ΔP_{cap} inside the liquid bridge.

radii on the order of 1 nanometer, the capillary pressure would reach the extreme value of 1,000 atmospheres. What is yet unclear is what happens in very narrow pore conditions, when the meniscus radius is approaching the size of a water molecule. It is likely that the macroscopic theories leading to Kelvin equation break down under these molecular-level conditions.

On the basis of equations 3 and 4, assuming that macroscopic theories remain valid, one might think that extreme dry conditions are the best conditions for cohesion resulting from capillary pressure. This is not true for one simple reason: *what is important is not the pressure in the liquid bridge but the force that pulls the particles to each other*. Since $[Force] = [Pressure] \times [Bridge \text{ cross-sectional area}]$, the shrinkage of the liquid bridge has to be considered also. As the atmosphere becomes dryer, the attractive pressure increases but, simultaneously, the area decreases. The mathematical analysis shows that for two *smooth* spherical particles, the liquid bridge shrinkage when the RH decreases is exactly compensated by the increase of the attractive capillary pressure. This leads to the following result for the

capillary force between two spherical particles in contact (Fisher and Israelachvili 1981):

$$F_{cap} \cong 2\pi R \gamma_{LV} \cos\theta_e \quad (5)$$

where R is the particle radius and θ_e the equilibrium contact angle between the liquid and the solid particles (see fig. 2). Surprisingly, this expression does not contain any parameter related to the meniscus size. In other words, it predicts that the force should be independent of the volume of liquid in the bridge, even in very dry conditions. This is in contrast to the experience of any child who knows that the cohesion of sand totally saturated by water is as small as that of sand that is totally dry and that the optimum cohesion is obtained at some intermediate water content. The decrease in cohesion when the amount of water is so large that it starts filling all the space between the sand grains is easy to understand, because in those conditions approaching liquid saturation the menisci progressively coalesce, and the water/air interface is repelled toward the outer surface of the sand heap and water flows around the particles. The decrease in cohesion when the amount of water becomes very small is much less obvious and has been explained only recently (Albert et al. 1997; Halsey and Levine 1998; Hornbaker et al. 1997). The explanation lies in the roughness of the particles. All surfaces are rough at some length scale, and sand grains are no exception. At very small RH, say, of the order of 5 percent, capillary condensation occurs only between the two asperities (or spikes) in contact. This is the “asperity regime.” “Asperity” refers to single spikes. “Roughness” refers to a whole profile with many spikes in which the force increases nonlinearly with RH. A second regime appears when the menisci between neighboring asperities merge but the cross section of the liquid bridge is still small compared to the radius of curvature of the particles. Here the force increases linearly with the liquid volume. A third regime, the classical saturation regime, in which the force is independent of liquid volume, is recovered when the size of the bridge becomes comparable to the roughness. Finally, the cohesion vanishes when all liquid bridges coalesce, and water percolates through the medium. All four regimes are summarized in figure 3. The important point—trivial for all experienced sand castle builders—is that there is an optimum water content for cohesion that provides the strength, bounded by humidity conditions, both high and low, both of which lead to collapse.

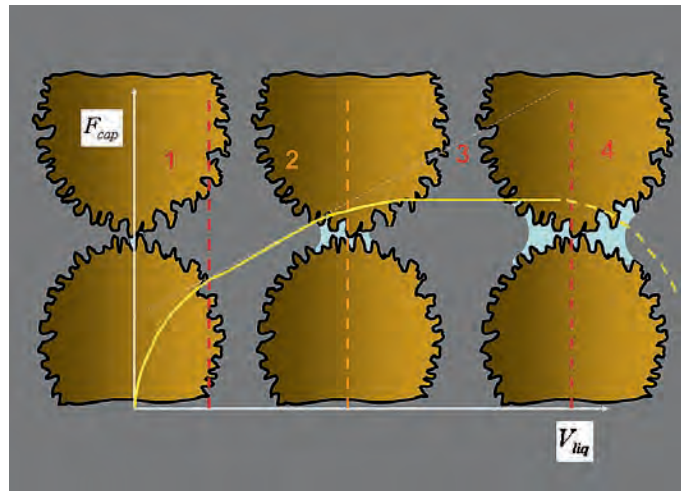

FIGURE 3 The attractive force due to a capillary condensation bridge between two spherical particles with a rough surface exhibits four different regimes. In regime 1 (asperity regime), condensation takes place between the asperities in contact, and the cohesive force increases nonlinearly with the amount of water. In regime 2 (roughness regime), the force increases linearly with the amount of water due to the lateral spreading of the liquid bridge over several asperities. However, in this regime, the meniscus is not yet sensitive to the average spherical curvature of the particles. In regime 3 (classical regime), the meniscus is no longer sensitive to the roughness, and the cohesive force is independent of the amount of water, as between two smooth spheres. Finally, in regime 4 (saturation regime), when so much water has been added that neighboring liquid bridges coalesce, the cohesion vanishes.

Can the cohesion of clays be explained only in terms of capillary forces, like that of sand? No universally valid answer can be given to this question, due to the extreme variability of clay surface properties, but capillary forces always contribute at least to some part of cohesion. However, the calculation of the cohesion is not simple because the form and nature of the clay particles is not simple either. We will come back to this subject later.

Electronic and Ionic Polarization Forces: The Strength of Cement

Besides capillary forces, the most universal attractive forces are undoubtedly dispersion or van der Waals forces, which are due to electronic polarization phenomena. As electrons orbit the nuclei of a molecule, they induce a temporary deformation of the electron cloud of the neighboring molecule.

This in-phase deformation of the two electron clouds generates an attractive force that is strong when the molecules are in contact but that decays rapidly as the separation distance increases. Doubling the separation distance leads to a sixty-four-fold decrease in the force. Between larger bodies, for instance, mineral particles, containing a large number of atoms, the situation is different because one has to sum the interaction of every atom of the first particle with all the atoms of the second particle. This leads to a force that is still very strong at contact but that decays much more slowly with distance. The theory of van der Waals forces has been extensively developed, and the forces can be computed very accurately, provided the shape of the particles and their separation are known. For instance, the expression for the attractive van der Waals pressure between two plates that are alike and of finite thickness, t , parallel to each other at distance D in a third medium, is shown in equation 6 (Israelachvili 1992). It has been confirmed experimentally by direct force measurements between two mica surfaces.

$$P_A = -\frac{A}{6\pi} \left[\frac{1}{D^3} + \frac{1}{(D+2t)^3} - \frac{2}{(D+t)^3} \right] \quad (6)$$

where A is the Hamaker constant, which represents the physics of the dipolar interactions between atoms giving rise to the attractive force. A known feature of van der Waals forces is that the Hamaker constant A is not very sensitive to the precise composition of the material, within a given family of minerals. The Hamaker constant for the surface of muscovite mica in water, determined experimentally, is 2.2×10^{-20} J (Bergström 1997). The Hamaker constant for different clays such as illite, kaolinite, montmorillonite, and chlorite is not much different. Thus the van der Waals pressure between two 1-nanometer-thick montmorillonite platelets at a separation of 1 nanometer is approximately 10 atmospheres, which is smaller than the capillary pressure. At a separation of 0.5 nanometer, it is close to 100 atmospheres. For kaolinite or illite platelets, which are thicker, the pressure would be approximately 20 percent more, which is not a significant difference.

Akin to van der Waals forces are the so-called ion-ion correlation forces. Instead of being due to the polarization of electron clouds, they are due to the polarization of ion clouds. Many mineral particles bear an electric charge. Whatever the origin of the surface charge, it has to be compensated by a charge of equal magnitude and opposite sign. This compensating charge is brought about by a cloud of ions

of opposite sign, the counterions. The cloud of counterions constitutes the ionic double layer. When two double layers face each other, they undergo strong fluctuations. An excess of ions on one side with respect to the midplane generates a fluctuating deficit of charge on the other side. This generates an attractive force that may become highly significant when the charge density on the particles is high and when the counterions are multivalent ions, like Ca^{2+} ions. This is the case in ordinary Portland cement and also in calcium-exchanged smectite clays (Van Damme 2002). On the other hand, ion correlation forces are totally inactive in neutral or weakly charged clays such as kaolinite.

Can Water Be the Glue? A Sample Case

In light of the previous discussion, an experimental study was performed on a model earthen material, with the aim of comparing measured cohesion values with calculated ones (Gélard 2005). The samples were prepared by mixing fine sand with a kaolinite clay slurry in water at neutral pH. Enough water was added to produce a soft paste consistency. The mixture was placed into cylindrical molds (height: 76 mm; diameter: 38 mm) and allowed to dry at room temperature at about 60 percent RH. Samples with three different clay/sand ratios were prepared: 5, 10, and 15 percent, weight by weight.

Scanning electron microscopy (SEM) (fig. 4) and synchrotron radiation microtomography (fig. 5) of this experimental earthen material show that the sand particles are covered by a layer of clay platelets and are linked by clay bridges with a shape that is clearly reminiscent of liquid capillary bridges. This shape may be interpreted as the signature of the kaolinite bridges that formed during impregnation of the sand with the clay in water slurry. Similar configurations are found in natural sedimentary rock samples (lower right inset of fig. 4).

Cohesion in the experimental earthen material was measured by classical soil mechanics testing methods in a triaxial apparatus allowing for application of a confining pressure to the sample (Muir Wood 1990). Cohesion was found to be highest in the sample containing 15 percent clay, at a value of 120 KPa, or 1.2 atmospheres (Gélard 2005). A cohesion value of a few atmospheres is low, and, indeed, our samples are very brittle, but this is expected for this type of illite- and smectite-free sandy material.

This cohesion value (120 KPa) can be compared to the cohesion calculated for a simple model fabric inspired by the micrographs of the experimental material, that is, two

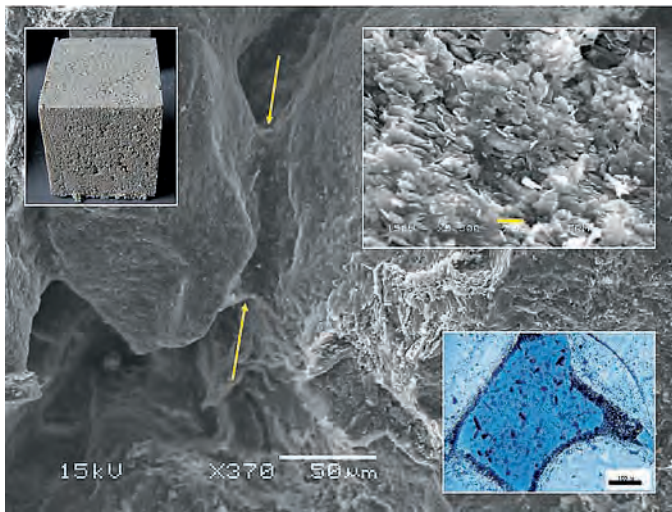

FIGURE 4 SEM image of the model experimental earthen material used in this study. A clay bridge between two sand particles is clearly visible in the background image. Upper left inset: A picture of the molded earthen block (size ~ 10 cm). Upper right inset: High-magnification SEM image of the clay coating on the sand particles. Lower right: For comparison with the experimental earthen material, an SEM image of a naturally occurring, clay-rich sandstone, showing the clay bridge (dark blue area) between the sand grains.

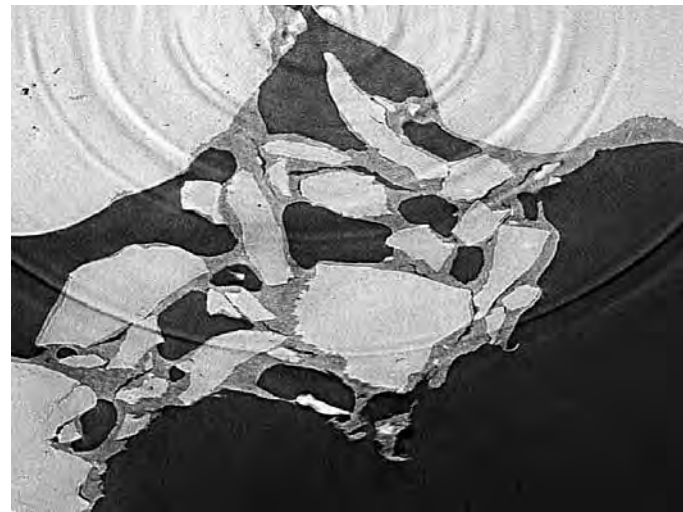

FIGURE 5 2D slice of a 3D image of our experimental earthen material obtained by X-ray synchrotron radiation microtomography. Notice the clay coatings and the clay bridges around and between the sand particles.

spherical sand particles separated by a porous bridge of kaolinite particles (fig. 6). As pointed out earlier, it is difficult to take fully into account the complex fabric of the clay platelets in the experimental material. However, the essential features of this fabric can be incorporated into the model. Those features are (a) the platelets are rigid particles with a high width/thickness ratio, which brings them on average in *almost* parallel orientation when they are densely packed; and (b) due to this small but significant disorientation, the true edge-to-face contact area between platelets is also small, on average. These two features were incorporated into the model by keeping a small contact area but replacing the orientational disorder with a stacking disorder. The platelets were assumed to be parallel to each other but with a strong lateral disorder such that only a small fraction of the surface of each platelet is facing its nearest neighbors. In addition, the disorder is self-similar, meaning that the overall geometry of the system is the same at all length scales (fig. 7). This model has already been used to calculate the contribution of van der Waals forces to the cohesion of pure clay deposits (Van Damme et al. 1985; Fripiat and Setton 1987).

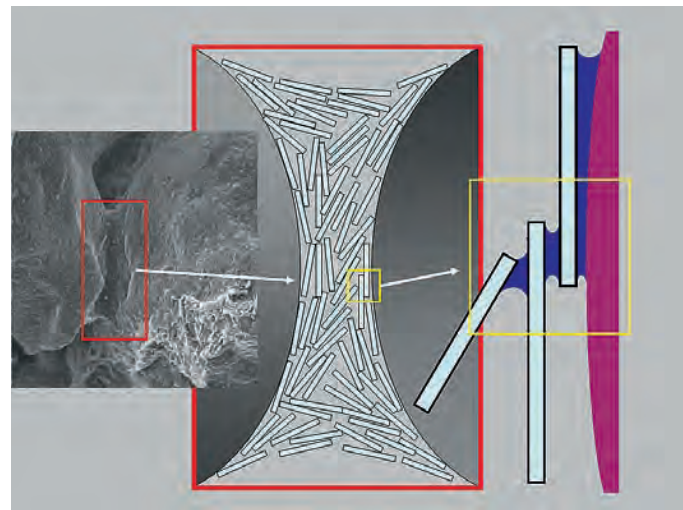

FIGURE 6 Center: Simplified model of the sand/clay fabric based on the SEM image (left) and the X-ray synchrotron radiation microtomography (see fig. 5) of the experimental earthen material. Two sand particles are bridged by clay. The clay bridge is made of rigid kaolinite platelets, mostly in low angle, edge-to-face contact (center). Capillary condensation occurs between clay platelets and also between sand grains and clay platelets (right).

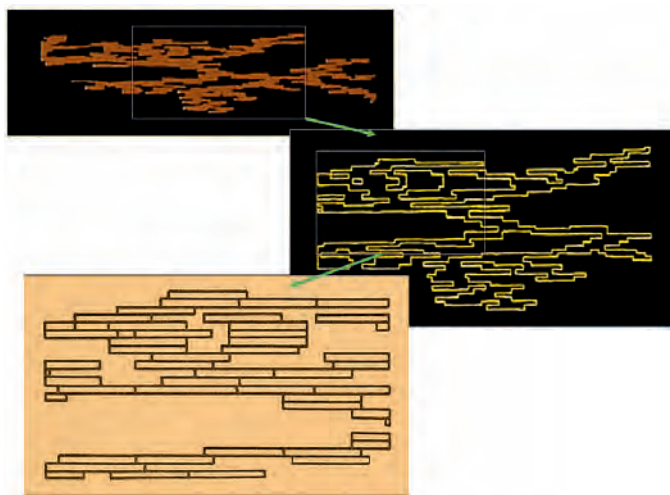

FIGURE 7 Sketch of the simplified model used to calculate the cohesion in the clay bridge between sand grains (see fig. 6, center): the orientational disorder of figure 6 has been replaced by a translational disorder. The average overlap area between neighboring platelets is small, as in the edge-to-face contacts.

We used the same model here, allowing the platelets to be separated by liquid water coming from condensation of the vapor. Capillary condensation starts between neighboring particles and extends progressively toward larger separations. A capillary gap is either totally filled by water, if the relative humidity is higher than the value given by Kelvin equation (eq. 4), or totally empty, if the relative humidity is lower. We assumed that the distance of closest approach of the platelets was the equilibrium meniscus curvature radius at the relative humidity of the experiments (60%), that is, ≈ 2 nm. Thus only capillary forces between nearest neighboring platelets contribute to the cohesion. The capillary pressure for a radius of 2 nm amounts to $\sim 7 \times 10^7$ Pa, that is, 700 atmospheres. At the same distance, with a Hamaker constant of 3×10^{-20} J, the van der Waals pressure is only 2×10^5 Pa (2 atmospheres), which is 350 times smaller than the capillary pressure. Without any further calculation, this means that the van der Waals contribution to the cohesion of our sample is negligible.

Two ingredients are still missing before a quantitative estimate of the macroscopic cohesion can be made. One is the fraction of platelet surfaces in nearest-neighbor configuration. We assumed, as previously (Fripiat and Setton 1987), that this is on the order of 1 percent. This is low, but it is well in line with edge-to-face contacts between platelets

in kaolinite. The last data needed is the cross section of the clay bridge, s , relative to the sand grain cross section. From the SEM and synchrotron data, this was estimated to be between 0.1 and 0.4. The cohesion values obtained for these two boundaries are summarized in table 1. The calculated capillary cohesion is of the right order of magnitude. It is very close to the experimentally measured value for $s \approx 0.3$. This value is in qualitative agreement with the SEM and microtomography data.

What can we learn from this discussion of cohesion forces and from the comparison between experiments and simplified models? The first lesson is certainly that cohesion of earthen materials is a property controlled by several different factors. Depending on the types of minerals in the earthen materials and their morphology, particle size, and texture, the important forces may be quite different.

Another lesson is that water is not itself necessarily the enemy of cohesion. Water films control capillary forces, but they also mediate the action of ion correlation forces, and they lubricate contacts between grains, allowing for particle position adjustment toward stable positions. In some cases, such as the model experimental material used in this study, capillary water is virtually the only source of cohesion. In other earthen materials containing highly charged mineral particles and ions, such as some calcium-smectites, the water-controlled contribution of the ion correlation forces to cohesion may be much higher (this is not the case for sodium-smectites, due to the low charge of the sodium ions). Thus, in general, the best conditions for high cohesion are not the driest conditions. For any earthen material, there should be an optimal water content for optimal cohesion and preservation. In dry and hot climates, this optimal water content may be greater than the existing water content in equilibrium with the surrounding atmosphere. Appropriate

Table 1 Calculated Cohesion (C) of the Sand/Kaolinite Experimental Material as a Function of the Fraction of Kaolinite Platelet Surfaces in a Nearest-Neighbor Situation (s)

s	C (kPa)
0.1	15
0.2	60
0.3	135
0.4	240

rehumidification may prove necessary, up to the optimum. Finally, it should be pointed out that finding and maintaining this optimum water content may also be important for the cohesion of any decorative coating made of fine-grained pigments.

Acknowledgments

The authors gratefully acknowledge the Conseil Régional Rhône-Alpes for providing a grant to David Gélard. We are also indebted to Stephane Sammartino for providing access to the ESRF synchrotron facility in Grenoble, France.

Notes

- 1 Established in 1997, Project TERRA is a partnership between the Getty Conservation Institute, the International Centre for Earth Construction–School of Architecture of Grenoble (CRATerre-EAG), and the International Centre for the Study of the Preservation and the Restoration of Cultural Property (ICCROM), Rome. Among other goals, Project TERRA fosters cooperative scientific research on binding and deterioration mechanisms of earthen materials.

References

- Adamson, A. W., and A. P. Gast. 1997. *Physical Chemistry of Surfaces*. 6th ed. New York: Wiley.
- Albert, R., I. Albert, D. Hornbaker, P. Schiffer, and A.-L. Barabási. 1997. Maximum angle of stability in wet and dry spherical granular media. *Physical Review E—Statistical Physics, Plasmas, Fluids, and Related Interdisciplinary Topics* 56 (6): R6271–74.
- Bergström, L. 1997. Hamaker constants of inorganic materials. *Advances in Colloid and Interface Science* 70 (1–3): 125–69.
- Fisher, L. R., and J. N. Israelachvili. 1981. Direct measurement of the effect of meniscus forces on adhesion: A study of the applicability of macroscopic thermodynamics to microscopic liquid interfaces. *Colloids and Surfaces* 3 (4): 303–19.
- Fripiat, J. J., and R. Setton. 1987. Cohesion energy in anisotropic particles aqueous slurries. *Journal of Applied Physics* 61 (5): 1811–15.
- Gélard, D. 2005. Identification et caractérisation de la cohésion interne du matériau terre dans ses conditions naturelles de conservation. Ph.D. diss, Université de Grenoble.
- Halsey, T. C., and A. J. Levine. 1998. How sandcastles fall. *Physical Review Letters* 80 (14): 3141–44.
- Hornbaker, D. J., R. Albert, I. Albert, A.-L. Barabasi, and P. Schiffer. 1997. What keeps sandcastles standing? *Nature* 387 (6635): 765.
- Israelachvili, Jacob N. 1992. *Intermolecular and Surface Forces*. 2nd ed. Ed. Jacob N. Israelachvili. London: Academic Press.
- Muir Wood, David. 1990. *Soil Behaviour and Critical State Soil Mechanics*. Cambridge: Cambridge University Press.
- Nedderman, R. M. 1992. *Statics and Kinematics of Granular Materials*. New York: Cambridge University Press.
- Van Damme, H. 2002. Colloidal chemo-mechanics of cement hydrates and smectite clays: Cohesion vs. swelling. In *Encyclopedia of Surface and Colloid Science*, ed. A. T. Hubbard, 1087–1103. New York: Marcel Dekker.
- Van Damme, H., P. Levitz, J. J. Fripiat, J. F. Alcover, L. Gatineau, and F. Bergaya. 1985. Clay minerals: A molecular approach to their fractal microstructure. In *Physics of Finely Divided Matter: Proceedings of the Winter School, Les Houches, France, March 25–April 5, 1985*, ed. N. Boccara and M. Daoud, 24–30. Springer Proceedings in Physics, no. 5. Berlin: Springer-Verlag.

Geology and Hydrogeology at the Mogao Grottoes, Dunhuang

Chikaosa Tanimoto, Chunze Piao, Keigo Koizumi, Shuichi Iwata, Tadashi Masuya, Li Zuixiong, Wang Xudong, and Guo Qinglin

Abstract: *The Mogao Grottoes are located at the eastern edge of the Mingsha Dunes and face toward the Sanwei Mountains, a range within the Qilian Mountains. The caves were excavated into a cliff along the west bank of the Daquan River. The rock stratum in which the caves were excavated is the alluvial and pluvial Jiuquan conglomerate, containing argillaceous and calcareous cementation. The wall paintings in the caves are subject to severe deterioration caused by recrystallization of salt, related to the movement of liquid water and water vapor in the rock formation. This deterioration has resulted in the partial separation of plaster from the cave roofs and walls. Our measurements of relative humidity in drill holes made into the walls of caves 72 and 108 suggest that even if the cave surface registers low humidity (30–50%), the humidity at a depth of 30 centimeters is almost 95 to 100 percent. This suggests that moisture moves from inside the rock formation to the cave surface. We consider four possible sources for the water and moisture affecting the Mogao caves: river water from the Daquan, rainwater from the top of the cliff, moisture moving through pores in the permeable rock formation and through fissures, and excessive irrigation of the vegetation in front of the caves. This paper describes the regional movement of groundwater that reaches the Mogao caves and the possibility that this groundwater is the source of moisture moving through the rock in which the caves were excavated.*

Knowledge of geology and rock mechanics can play an important role in the preservation and conservation of natural stone monuments. Not only does this knowledge directly contribute to repairs and reinforcement of these monuments; it also deepens our understanding of the geologic environment, construction method, long-term durability, weather-

ing and deterioration processes, the effect of rock joints, movement of groundwater and moisture, and global climate change. We have focused our research on the relationship between the movement of moisture within relatively young porous rocks and the resulting deterioration of these rocks.

Contrary to what may be the common wisdom, groundwater must exist even in an arid area such as the widespread desert of Egypt (Tanimoto, Tonouchi, and Yoshimura 1992; Tanimoto, Yoshimura, and Kondo 1993). Groundwater can move incredibly long distances, sometimes over several thousand kilometers, through faults, fissures, and pores in solid rock. As groundwater, even water vapor, moves along the same path repeatedly over a long time, it transports salt substances from one place to another, and evaporation accelerates the accumulation of salts inside the rock and on the rock surface. The Mogao caves are no exception to this process. It occurs in the rock behind many of the caves' wall paintings and causes the paintings to separate from the walls.

Considering the rivers and oases, vegetation, and subsurface structure in the Dunhuang area, we suggest through our geologic survey and satellite image analysis that a certain network of groundwater exists in the area.

Geographic and Geologic Environments of the Mogao Area

The Mogao Grottoes are located on the southeastern margin of the Dunhuang oasis 25 kilometers from the city of Dunhuang, as shown in figure 1. The figure is a composite obtained by superposing possible surface water flows onto a LANDSAT5/TM satellite image. The Sanwei Mountains are to the east of the Mogao Grottoes, and the Mingsha sand

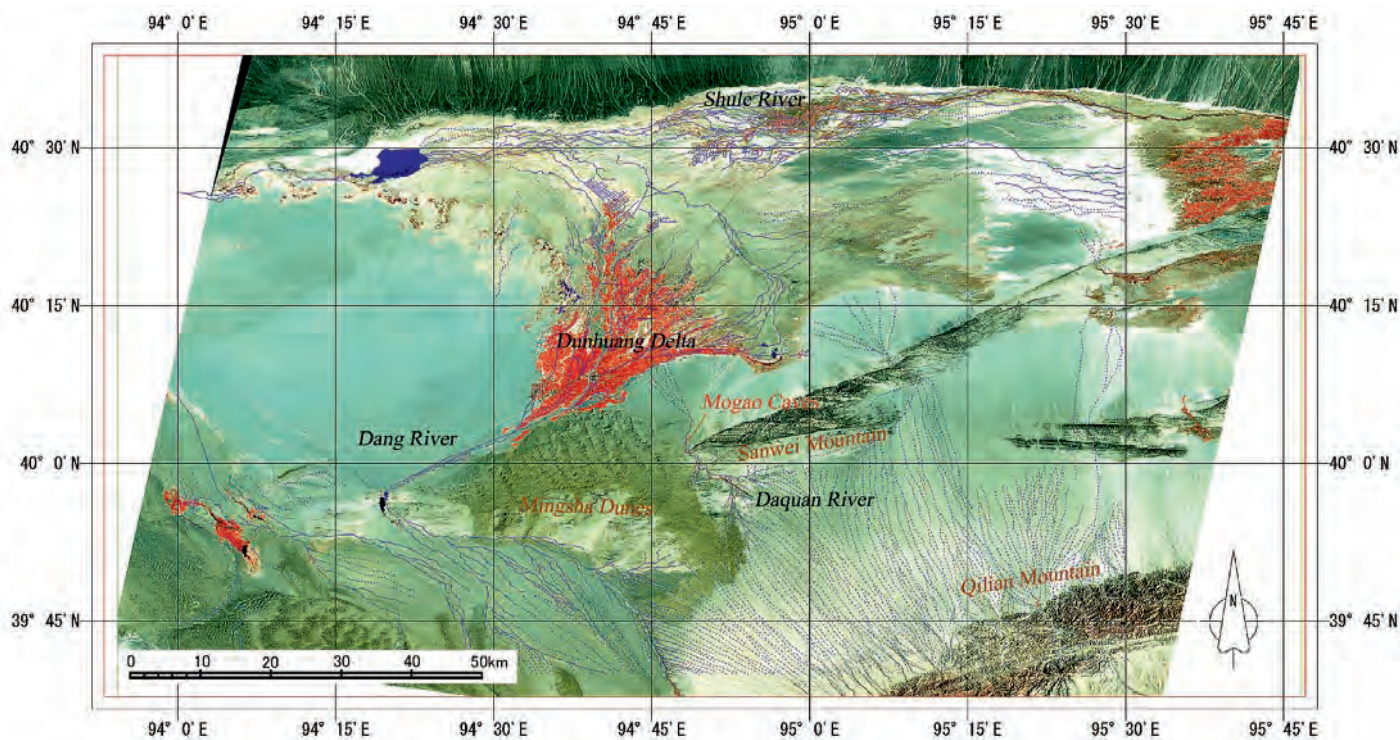

FIGURE 1 Composite topography and LANDSAT5/TM satellite image of the Dunhuang area. Red areas show vegetation.

dunes are to the west, with the Daquan River valley in between. The vast Gobi Desert is to the north. The Mogao area lies at the western end of the Hexi corridor, a long and narrow basin in northwestern China, and is constantly under the influence of the Mongolian high pressure system. The climate is characterized by extreme aridity, low precipitation, great seasonal temperature variation, and frequent windblown sand activity. The average annual precipitation is 23.2 millimeters; annual evaporation is 3,479 millimeters, which is 150 times the precipitation level; and the average relative humidity is 32 percent (Ling Yuquan et al. 1997).

From the topography of the Dunhuang area, it can be seen that the basin surrounded by the Sanwei and Aerjin (Qilian) Mountains is the catchment area for the Dang, Yulin, and Daquan Rivers (fig. 2). The Aerjin fault belt, which consists of shear-compression faults, stretches over 1,000 kilometers in western China. The Daquan River, which runs in front of the Mogao Grottoes, was formed by a conjugate fault system and frequent floods since the beginning of the Quaternary period around 1.8 million years ago.

The rock of the Mogao area consists of two different strata, the Precambrian gneiss and the Pleistocene conglomerate. During the Quaternary period, about one million years ago, aggressive tectonic movements took place, causing granite to be intruded into the gneiss in the Dunhuang area. It can be seen that the major direction of high mountain ridges, which were subjected to extraordinarily high thrust forces, is generated from the south. The magnitude of the tectonic stress in this area is believed to be the highest in the world (Kaizuka 1997; Ma Lifang, Qiao Xiufu, and Liu Nailong 2002). Many textbook reverse faults can be seen along the Daquan River. During the Quaternary period, the Precambrian gneiss was strongly thrust over the Pleistocene conglomerate (fig. 3).

The Aerjin Mountains, whose highest peak is 5,788 meters, are the western extension of the Qilian mountain range and form a tremendous wall 3,600 to 4,400 meters high in the east-west direction. There is a huge highland basin 4,000 to 5,000 meters above sea level to the south and another at 1,400 to 2,000 meters between the Aerjin and Sanwei Mountains. These plateaus, highlands, and basins contribute to a large underground reservoir (aquifer) that provides steady groundwater year-round. It is important to note that many highland lakes exist at the several-thousand-

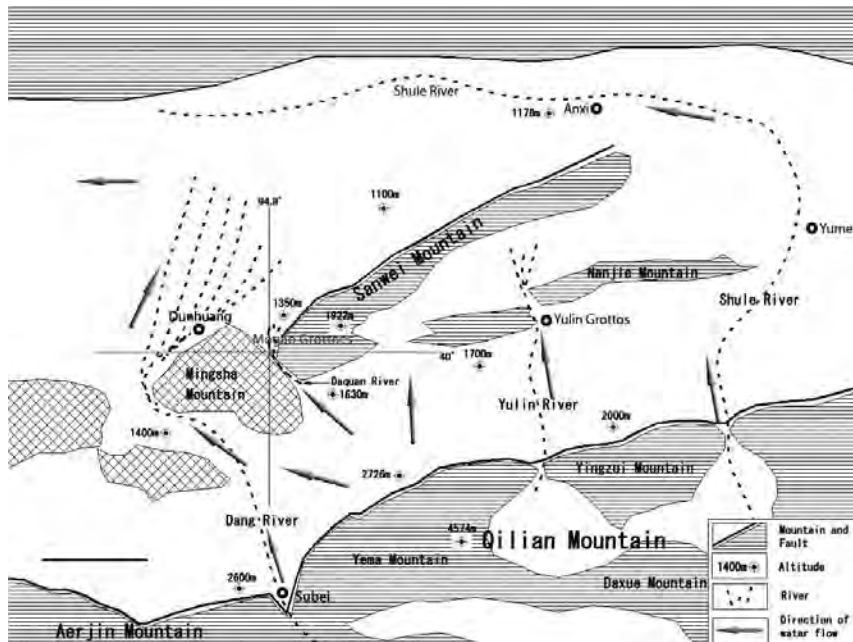

FIGURE 2 Topographical location of the Dunhuang area.

meter level. That is, the existence of many large highland lakes in Qinghai province (not visible in fig. 1) strongly suggests that the area is rich in groundwater.

The underground reservoir sandwiched between the Aerjin (Qilian) and Sanwei Mountains provides water from south to north and from east to west as the main stream. A

large amount of water is received by the Dang River, running from south to north, which resulted from faulting in the north-south direction. Since the magnitude and scale of the faulting at the Daquan River are much less than that at the Dang River, the water volume of the Daquan is much less than that of the Dang south of the Mogao Grottoes. However, the movement of water along the Daquan River could be a possible source of water and moisture affecting the Mogao Grottoes.



FIGURE 3 Reverse fault seen along the upper Daquan River where the Precambrian gneiss has been thrust over the Pleistocene conglomerate.

Geologic Profile of Mogao Conglomerate

The geologic profile of the Mogao area is described by Kuchitsu and Duan Xiuye (1997). The 215- to 230-meter-thick local conglomerate was formed with sediments/deposits from frequent floods in the early, middle, and late Pleistocene. The different strata in this conglomerate are classified into three groups, Q1, Q2, and Q3, which date respectively to 1.8–0.78, 0.78–0.13, and 0.13–0.01 million years ago (Ma). The youngest formation formed in the Holocene (0.01 Ma–present); this group is called Q4. In the literature, the Q1 and Q2 groups are designated old alluvial fan deposits, and the Q3 and Q4 groups are designated new alluvial fan deposits (Kuchitsu and Duan Xiuye 1997). In cross section, the approximate thicknesses of the four groups on the south side of the Nine-Storey Pagoda at Mogao are 35–40 meters, 160–70 meters,

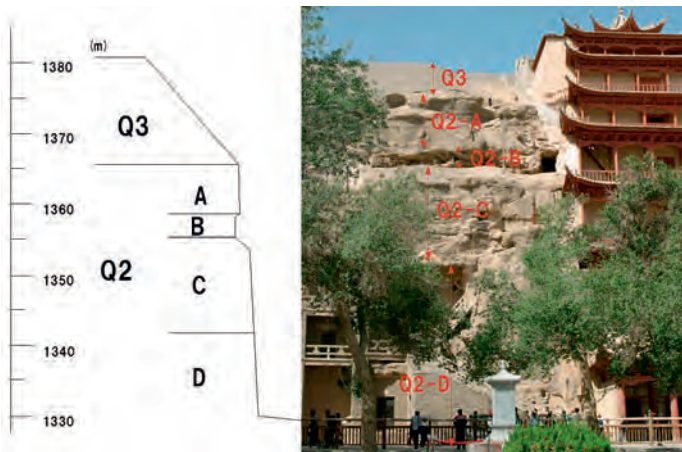

FIGURE 4 Geologic profile of the Q2 conglomerate layer in which the Mogao Grottoes were excavated.

and less than 20 meters for Q1, Q2, Q3, and Q4 in total thickness from the bottom to the top.

Many different kinds of gravels are observed in the conglomerate, showing that floods and glaciers in the past had transported these gravels from the Qilian mountain

range over both near and far distances. Most of the Mogao Grottoes were excavated between the fourth and fourteenth centuries in the Q2 group, which is about 30 meters thick. The Q2 group is further subdivided into four layers—A, B, C, and D—based on the particle size distribution (fig. 4). In front of the Nine-Storey Pagoda, ground level is at an elevation of 1,330 meters. The Precambrian basement rock is believed to be below 1,100 meters elevation.

Satellite Remote Sensing

Because the Dunhuang basin between the Sanwei and Aerjin Mountains is situated in an arid region with little vegetation, it is easy for us to understand its geologic structure through satellite remote sensing. For our work, we examined satellite images of the Mogao area taken by LANDSAT5 and JERS-1 in 1996 and 1997. The LANDSAT5 image clearly shows a zigzag-like flow of the Daquan River (fig. 5a) and alluvial fan deposits (fig. 5b).

For our analyses, several combinations of spectral bands were chosen that emphasize differences in the reflec-

FIGURE 5 LANDSAT5 false-color image of the Mogao Grottoes.



(a)

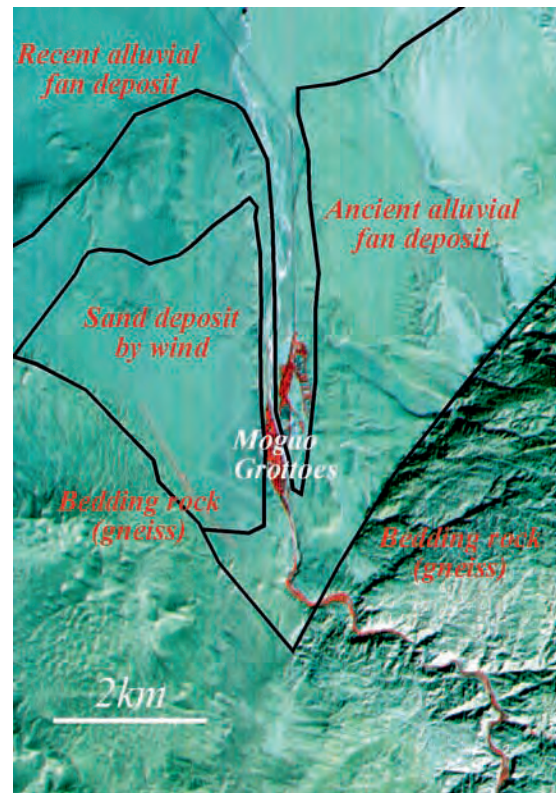

(b)

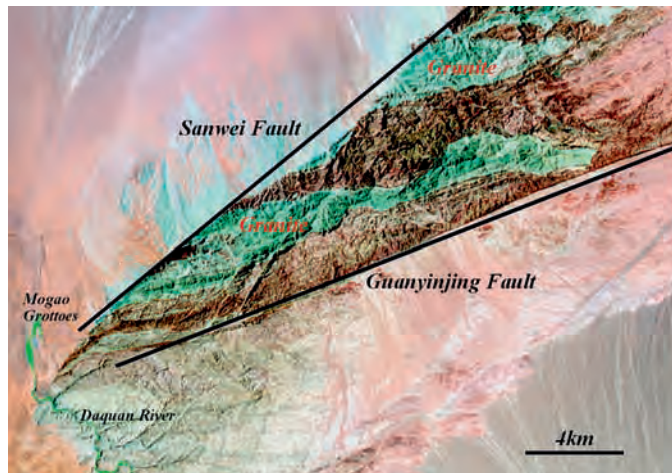

FIGURE 6 False-color satellite image showing faulting and granite intrusion (blue) in the Mogao area.

tance patterns of rocks. First a false color image (e.g., B:G:R = 2:3:4, where B:G:R shows the band that assigns blue, green, and red, respectively) was created from the satellite image. Then a *ratioing* image was obtained; that is, digital image processing was used to enhance the contrast between features in the image. Figures 5a and 5b are examples of false color images through B:G:R = 2:3:4. Figure 6 is another example of a false-color image of the Sanwei Mountains through B:G:R = 2:4:7. Two straight lines clearly appear in this image. They correspond to the Sanwei Mountain and the Guanyinjing faults, and they meet at the base of the Mingsha dunes, which are at the westernmost end of the Sanwei Mountains. Figure 6 shows that granite (blue in this image) intruded into the Sanwei Mountain formation (gneiss). On the north side of the Sanwei Mountains, the granite is cut off by the Sanwei Mountain fault, suggesting that tectonic movement took place after the intrusion of the granite.

Based on our satellite image analyses, we conclude that the present geologic situation of the Mogao area was produced in the following order:

1. formation of Precambrian metamorphic rock (gneiss) as the basement rock;
2. intrusion of granite;
3. fault movement and resulting crushing action;
4. uplifting of the earth's crust;
5. fault movement and resulting crushing action; and
6. formation of conglomerate strata in the Quaternary.

As figure 5a shows, the Daquan River changes its flow direction at many points along the faults. The Precambrian gneiss (fig. 5b) has been crushed heavily and turned counter-clockwise. A large dislocation is clearly visible in the strike direction.

Possible Water Sources Affecting the Mogao Area

It is suggested that young geologic formations with high porosity, such as the Eocene limestone in Giza, Egypt, and the Pleistocene conglomerate in Dunhuang, hold groundwater. Furthermore, depending on the hydraulic gradient (slope of the aquifer), not only groundwater but also water vapor slowly but constantly moves down through the chains of pores and fissures under high hydraulic pressure. Therefore, possible water sources affecting the Mogao Grottoes are the following:

1. capillary rise of water from the Daquan River through the conglomerate;
2. rainwater seeping down from the top of the Mogao cliff;
3. moisture moving through pores in the permeable strata and through fissures; and
4. irrigation water applied to vegetation close to the Mogao Grottoes.

Daquan River

Table 1 shows data obtained by the Dang River Control Office in Subei for the catchment areas and annual flow rates of the Daquan, Yulin, and Dang Rivers. The observed annual flow rate of the Daquan River was approximately 1.5 percent that of the Dang River from the observed water volume in 1980.

Table 1 Water Supply from the Qilian Mountains to the Daquan, Yulin, and Dang/Shule Rivers (Data from 1980)

	Catchment Area (km ²)	Annual Flow Rate (×10 ⁶ m ³ /yr)
Daquan	~250 (1%)	5
Yulin	>3,500 (12%)	48
Dang	>25,000 (87%)	366

Source: Dang River Control Office, Subei (Gansu province), China.

FIGURE 7 Depth profiles of relative humidity measured in drill holes made in (a) the floor of cave 72 and (b) the south and west walls of cave 108. Black dots show location of drill holes.

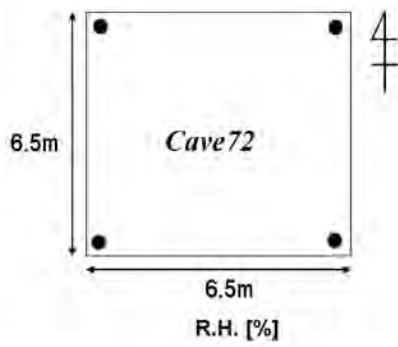

	NW	SW	SE	NE
0	34.3	30.7	30.7	30.4
10	64.9	70.4	83.1	67.1
20	73.7	73.6	83.3	75.9
30	94.5	89.6	99.5	94.2

(a)

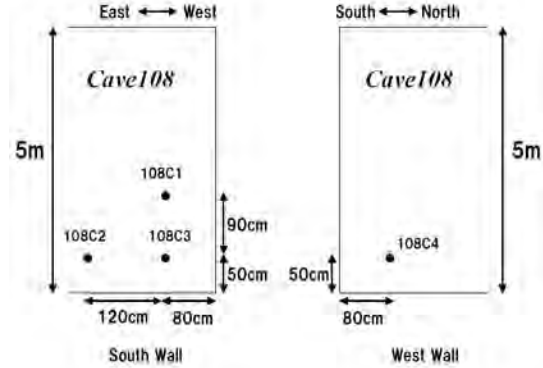

	South			West
	108 C1	108 C2	108 C3	108 C4
0	35.6	32.1	34.1	35.7
10	47.6	55.7	76.0	68.5
20	55.3	66.8	88.4	77.4
30	59.0	73.0	96.7	85.4

(b)

Water and Moisture Movement

Figures 7a and 7b show the depth profiles of relative humidity measured in drill holes, 30 centimeters deep and 4 centimeters in diameter, made in caves 72 and 108 at Mogao. The caves are located at the bottom of the cliff on the south and north sides of the Nine-Storey Pagoda. Figure 7a shows the aggressive change in humidity in cave 72 along holes drilled vertically downward into the floor at the four corners of the cave. The relative humidity at depths of 0 meter (floor surface), 10 centimeters, 20 centimeters, and 30 centimeters rapidly changes from 30–34 percent (floor surface) to 65–83 percent (10 cm) to 74–83 percent (20 cm) to 90–100 percent (30 cm). The same tendency is seen in cave 108. Figure 7b shows the depth profile of relative humidity along holes drilled horizontally into the wall at the southwest corner of cave 108. These results strongly suggest that moisture moves upward through the rock.

The movement of moisture or water through the rock formation beneath the floor of cave 72 has been verified through electric resistivity measurements carried out between the irrigation field in front of the cave and the cave. The irrigation field is filled with enough water to create a 20- to 30-centimeter-deep pond. The irrigation water moves from east to west, showing a low value of electric

resistivity in the range of 60 to 80 Ωm (fig. 8). These results suggest that the irrigation water should be minimized to the extent possible.

Summary

Based on our work at Mogao, we make the following observations:

1. Rivers run along faults with few exceptions, and these faults tend to be a cause of the deterioration of buildings and monuments over time. Therefore, in general, we should pay more attention to the existence of potential fissures relating to not only instability but also water conductivity, for better preservation of stone monuments.
2. Deterioration processes should be studied more intensively from the mechanical aspect (i.e., slaking, or the deterioration of rock due to the repetition of dry-wet conditions, salinization, loss of cementation, etc.).
3. Hydrogeologic features of the Mogao area should be examined from the macroscopic to the microscopic level.

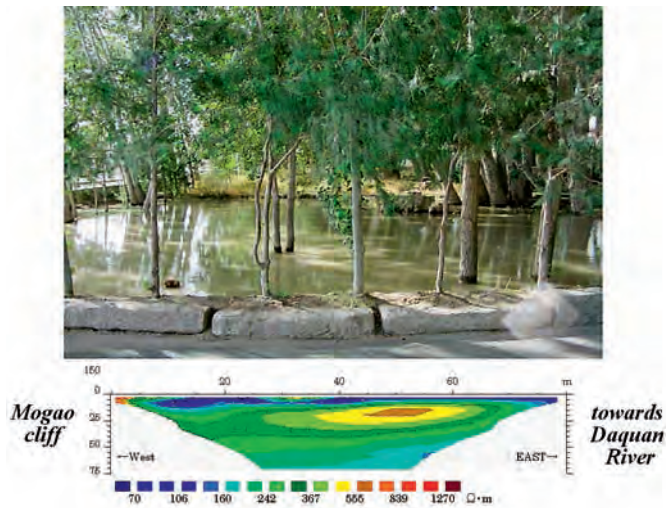

FIGURE 8 Irrigation pond in front of cave 72 (top) and electric resistivity measurements (bottom) in the rock beneath the cave.

It is important to obtain results from a variety of analytic methods in order to significantly contribute to a better understanding of the Mogao area's complicated geologic and hydrological issues. Only such an integrated approach will open up possibilities for preserving World Heritage Sites.

Acknowledgments

This joint work has been carried out with the help of many colleagues in China. The authors would like to express their sincere thanks to them, especially Xue Ping, Li Weitang, and Ding Shujun of the Dunhuang Academy.

References

- Kaizuka, S. 1997. *Landforms of the World*. Tokyo: University of Tokyo Press.
- Kuchitsu, N., and Duan Xiuye. 1997. Geological environment of the Mogao Grottoes at Dunhuang. In *Conservation of Ancient Sites on the Silk Road: Proceedings of an International Conference on the Conservation of Grotto Sites*, ed. N. Agnew, 244–48. Los Angeles: Getty Conservation Institute.
- Ling Yuquan, Qu Jianjun, Fan Jinshi, and Li Yunhe. 1997. Research into the control of damage by windblown sand at the Mogao Grottoes. In *Conservation of Ancient Sites on the Silk Road: Proceedings of an International Conference on the Conservation of Grotto Sites*, ed. N. Agnew, 213–26. Los Angeles: Getty Conservation Institute.
- Ma Lifang, Qiao Xiufu, and Liu Nailong, eds. 2002. *Geological Atlas of China*. Beijing: Geological Publishing House.
- Tanimoto, C., S. Tonouchi, and S. Yoshimura. 1992. Rock mechanical observation and high-tech use of latest prospecting techniques in archaeological findings in Egypt. In *Rock Characterization: ISRM Symposium, Eurock 92, Chester, UK, 14–17 September 1992 = Caractérisation des roches = Gesteinsansprache*, ed. J. A. Hudson, 456–61. London: British Geotechnical Society.
- Tanimoto, C., S. Yoshimura, and J. Kondo. 1993. Long-term stability of the underground cavern for the Pharaoh and the deterioration of the Great Sphinx. *International Journal of Rock Mechanics and Mining Sciences & Geomechanics Abstracts* 30 (7): 1545–51.

The Influence of Water on the Stone Carvings of the Yungang Grottoes

Huang Jizhong

Abstract: *The Yungang Grottoes World Heritage Site in Shanxi province was created in the late fifth and sixth century during the Northern Wei dynasty. The stone sculpture has suffered severely from capillary rise of groundwater, condensation, dissolution of mineral components, transformation of feldspar into clays, and freeze-thaw cycles. In recent decades coal industry-related pollution has worsened deterioration. This paper describes the types of stone weathering and the role of water and discusses current and future plans to mitigate deterioration through the exclusion or control of access of water to the cave temples.*

The Yungang Grottoes, excavated during the Northern Wei dynasty (460–524 C.E.), are located in the western suburb of Datong City, Shanxi province. Carved into the cliff of the Wuzhou Mountains and extending 1 kilometer from east to west, the site, with 45 major caves and 51,000 Buddha statues including reliefs, is one of the largest ancient grotto groups in China. The Yungang Grottoes were ratified as a key cultural heritage protected site in China by the State Council in 1961 and inscribed in the list of World Heritage Sites in 2001.

Over the centuries, the Yungang Grottoes have experienced weathering due to natural forces, primarily water (fig. 1), as well as man-made problems such as pollution from coal mining. Studies have shown that water at the site has four sources: capillary groundwater, condensation, seepage from the rock, and direct impact of rain.

Since 1960 channels have been dug on top of the escarpment above the grottoes to drain water to the east and west ravines and away from the site. In 1992 the Yungang Grottoes Research Institute for Historical and Cultural Relics, the

China National Institute of Cultural Property, and the Getty Conservation Institute conducted joint experimental research to control the seepage problem.

Over many years, the Yungang Grottoes Research Institute has undertaken studies and conducted conserva-



FIGURE 1 Weathering of the lower part of the west wall of cave 1 due to groundwater.



FIGURE 2 Tufa-shaped and stalactite-type weathering.

tion work. However, the pervasive problem of water damage has not been completely resolved, and the negative influence of water on the grottoes continues. Statistics from many years of observation show that among the forty-five major grottoes at the site, those that have a record of water seepage are caves 2, 3, 5, 6, 14, 21, 23, and 34.

Main Mechanisms of Water-Caused Deterioration

Powdering of the Sandstone

A layer of white or light yellow powderlike weathered substance forms on the surface of many statues and cave walls. White and hard stalactite-like weathering substances, with protruding granules 1 to 2 millimeters in diameter are also formed. This weathering is especially serious in the lower parts of all the caves and in the caves located in the east section (figs. 2, 3). The weathered products are extremely fragile and fall off at the slightest touch.

Flaking and Scaling

Flaking and scaling result in thin layers of stone lifting from the surface of statues and cave walls. The thickness of the detached layers is dependent on the size of the mineral grains. Flakes from coarse sandstone are about 3 to 4 millimeters thick; those from fine sandstone are about 0.5 to 1 millimeter thick. There is often multilayered exfoliation. Between the layers and between the detached layers and the base rock is white powder. In places with adequate sunlight and good ventilation, such damage is especially serious



FIGURE 3 Powderlike weathering.

(fig. 4), and one can often find detached flakes and scaling parallel to the surfaces of the statues and rocks.

Stratigraphic Weathering

Banded weathering occurs on the surfaces of the statues and rocks approximately parallel to the natural layers of rock (fig. 5).

Slablike Weathering

It is often the case that pieces of rock from the ceilings of caves and in the corners and on protruding parts of large statues detach and fall in the form of slabs 2 to 4 centimeters in thickness (fig. 6).



FIGURE 4 Scaling of the statues.



FIGURE 5 Stratigraphic weathering in cave 3.

Erosion by Wind and Acid Rain

Gamma ray and electrical instrumental tests show that the entrance pillars of caves 9, 10, and 12 are seriously eroded. Erosion of the five front pillars in caves 9 and 10, whose diameters are 80 to 100 centimeters, has reached a depth of 20 centimeters. Our study of weight-bearing safety factors indicates that they are in a dangerous condition. The weathering of these pillars has been caused mainly by wind and rain, especially acid rain, and snow. Due to the high content of SO_2 in the atmosphere in the district, as a result of coal mining and burning, acid rain and snow are prevalent, with serious consequences for the exposed statues. Figures 7a and 7b compare the different degrees of erosion of the same pillars on the outer and inner sides.

Water Sources in the Caves

There are four sources of water in the caves: (1) seepage directly from the ceilings and fissures in the walls; (2) capillary groundwater from the floors; (3) spring water (cave 2); and (4) atmospheric condensation.



FIGURE 6 Slab-type weathering and loss at the top of cave 19's side chamber.

There is a perennial spring in cave 2, which was eliminated during a reinforcement project in 1964, when a deep hidden ditch was dug to drain the water. This lowered the outflow level substantially, and as a result the spring no longer affects the cave.

The inside/outside temperature difference in the Yungang Grottoes in summer is large, and the humidity is as high as 100 percent during rain periods. When warm humid air flows into the caves and meets the comparatively cold rocks, the moisture condenses onto the surfaces. In cave 5, for instance, when the humidity inside the cave is 80 percent and the temperature inside is 10°C , the mass of condensed water over twenty-four hours is estimated to be 23 kilograms.

Water Quality and Its Influence on the Grottoes

During the period from 2002 to 2003, the chemical composition of many sources of natural water around Yungang were analyzed, including coal mine water, well water, cave 2 spring water, river water, cave seepage water, rain (snow), and bore hole and seepage water. These were compared with analyses undertaken in the 1960s.

Conclusions from analyses conducted over nearly four decades are as follows:

- Seepage water from cave 3 was found to be the closest to snow water in total mineral content, sulfate,



(a)



(b)

FIGURE 7 (a) Carvings on the inner sides of the pillars remain in comparatively good condition. (b) Carvings on the outer sides of the pillars are seriously eroded.

and chloride content, which indicates that this water is probably melted snow water.

- The mineralization of all the samples from bores B6, B7, B1, and T₃, cave 3 water, and cave 2 spring, as well as snow, water are less than 1,000 milligrams per gram, which means that there is good groundwater circulation, and those areas can be seen as a water containment system.
- The mineralization of water from a well in Yungang village and bore holes B₃ and B₁₀ is comparatively high, and water from those places and from the coal mine belong to the same category. They represent deep groundwater, with comparatively weak circulation. They have little to do with precipitation and are mainly influenced by the chemical environment of the deep system.

Based on the chemical analysis of the natural waters around the Yungang Grottoes, the pH, and the concentration of bicarbonate ion (HCO_3^-), a number of charts have been plotted (fig. 8). It is clear that bicarbonate content is higher in spring and seepage water than in snow and rain, while the spring water contains the highest bicarbonate because it has a large area to react with carbonate and dissolve bicarbonate.

The seepage water in the caves is rainwater, and it has only a short time to react with the carbonate rock. Therefore, the concentrations of bicarbonate in spring water are between that of seepage water and that of groundwater.

Similarly, the pH value of rain and snow is lower than that of the seepage and spring water. Rain and snow are characterized by their low pH value and high erosion ability. Figure 9 shows that the pH value of cave 2 spring water in 2003 has considerably decreased compared to that in the 1960s, especially in winter, when pollution becomes more severe and sometimes shows acidity. Meanwhile, the content of various ionic substances has increased, and changes in values of potassium, sodium and sulfate, and chloride (K^+ , Na^+ , SO_4^{2-} , and Cl^-) are especially obvious. The above changes are a consequence of the serious pollution in the Yungang Grottoes area.

Effects of Water on Yungang Sandstone Sculptures

Effects on Rock with Fissures

Infiltration of water through pores and fissures, followed by dissolution of salts and chemical reactions in the rock, results in both physical and chemical deterioration. For example,

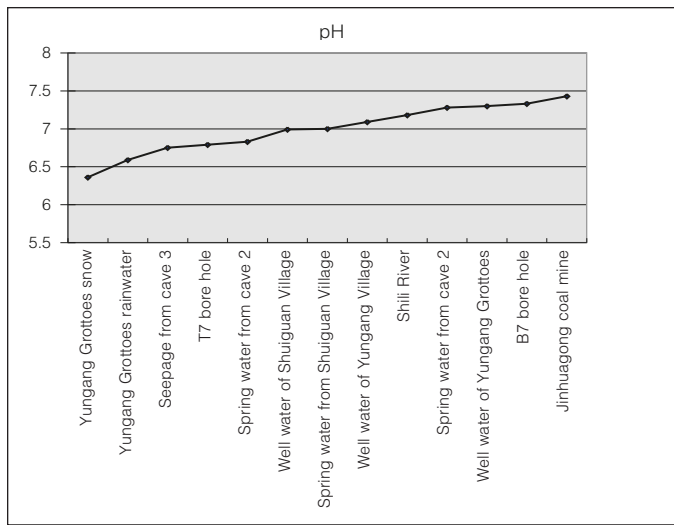

(a)

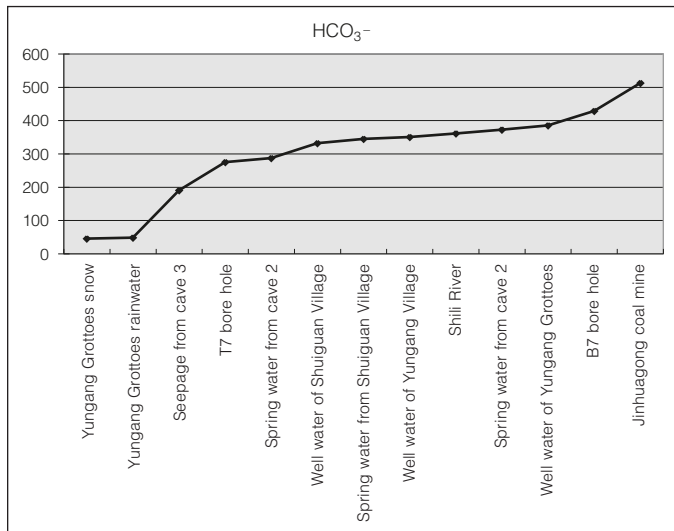

(b)

FIGURE 8 (a) The pH of and (b) the concentration of HCO_3^- in water.

chemical reaction of water may result in accumulation of clay and mineral substances within fissures. Hydrophilic clay and other minerals expand when water is absorbed and shrink when it is lost. This is why stone fragments have fallen from cave walls after rains that follow a long period of drought. For example, on August 18, 2002, after a period of rain, more than one ton of rock fell in cave 1.

Freeze-Thaw Damage. Freeze-thaw cycles at Yungang are one of the main causes of stone damage. Figure 10 shows

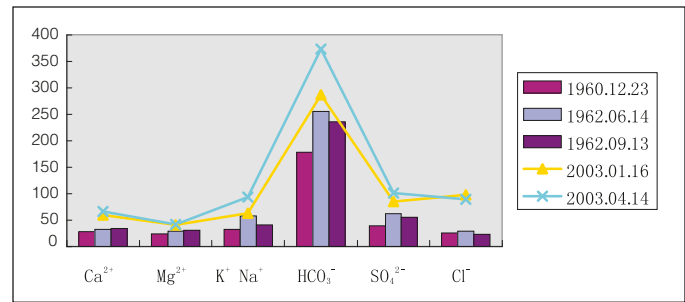

(a)

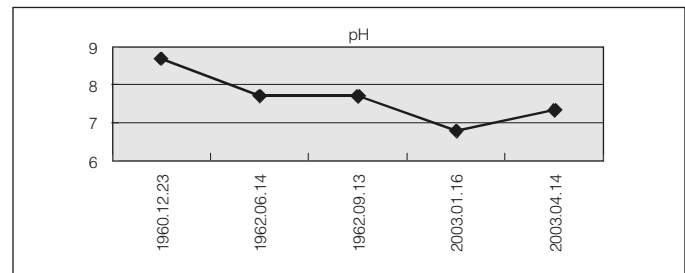

(b)

FIGURE 9 (a) Comparison of the cave 2 water quality in the 1960s and in the survey of 2003. (b) Comparison of the pH values of water in cave 2 in the 1960s and in the 2003 water quality survey.

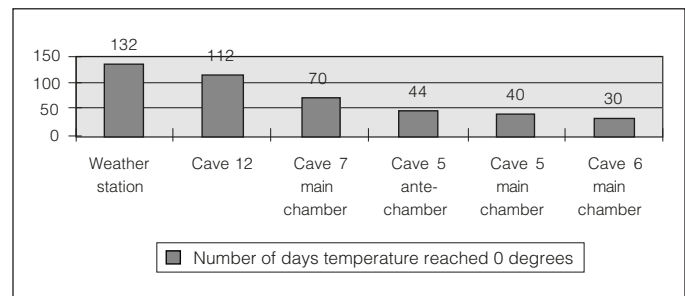
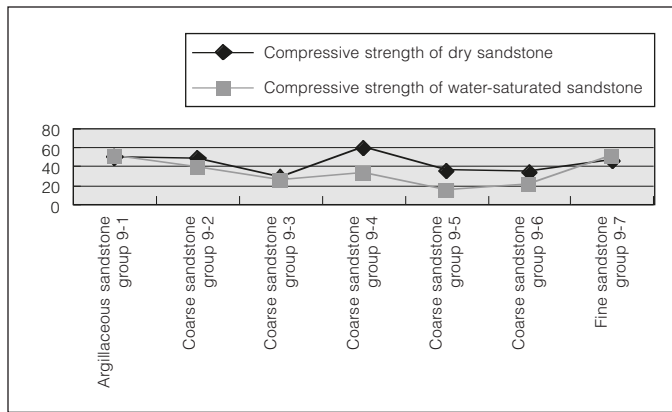

FIGURE 10 Number of days in 2002 and 2003 when the temperature reached 0°C inside and outside the caves.

the number of days in 2002 and 2003 when the temperature was below freezing inside and outside of caves 12, 7, 5 (front and back chambers), and 6.

Salt Crystallization Pressure. A frequently seen and pervasive weathering phenomenon of carved stone at Yungang is salt crystallization, resulting in powderlike weathering from salt fretting, flaking, and scaling, with loss and sub-florescence. When the concentration of salt gets to a certain point, the shear strength of the stone is exceeded. The sand-



(a)

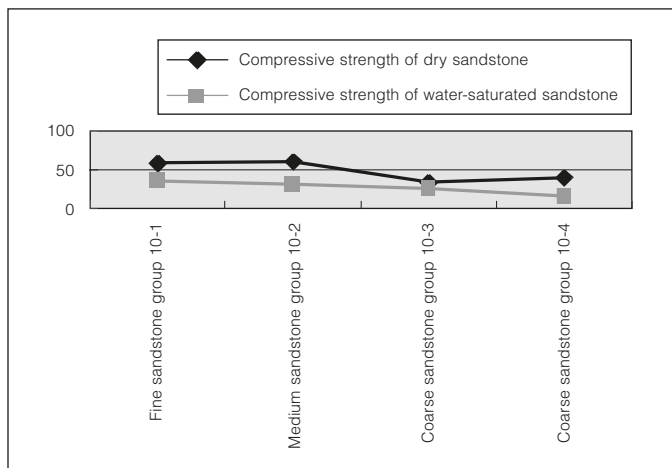

(b)

FIGURE 11 Uniaxial compressive strength comparison of dry sandstone and water-saturated sandstone.

stone at Yungang has a compressive stress of 10.8 and a shear stress of 18.7 Nmm⁻².

Hydration Pressure. Certain salts, including those found in the Yungang sandstone, react with moisture to form crystals containing lattice water. During this process, the volume of the crystals increases considerably. Although the hydration pressures of different salts containing water of crystallization vary with temperature and humidity and are sometimes considerably different, there is a common consequence for all: hydration pressures are greatest when temperature is low and humidity is high. Such pressures are comparable with the shear strength of the sandstone at Yungang. Figure 11 compares the uniaxial compression strength of the sandstone when it is dry and water saturated.

Chemical Effects of Water-Rock Reactions

A series of water-rock reactions occur during the chemical weathering process of the sedimentary rock of Yungang. Among those reactions, the following are most important: the solution of carbonate cement, the hydrolysis of sedimentary rock, and the formation and transformation of iron oxide and iron hydroxide minerals.

Solution of Carbonate Cement. Carbonate cement exists extensively in the fresh sedimentary rock at Yungang. Its content in coarse and medium sandstone is often between 10 and 20 percent. Therefore, the solution of cement can result in obvious changes in porosity and permeability of the rock. Comparison of the characteristics reveals that as the degree of weathering increases, more carbonate cement will dissolve and the porosity of the rock will increase. Mercury porosimetry on sedimentary rock has shown that rock porosity is also increased and that the radius of the pores of the rocks becomes larger as porosity increases; consequently, water is absorbed by the rock in greater amounts.

Hydrolysis of Feldspar. Feldspar is hydrolyzed in surface weathering. Hydrolysis produces a number of substances. Feldspar in the sedimentary rock at Yungang is mainly microcline, which experienced alternation to kaolinite in the lithogenic process. Therefore, it is comparatively difficult to identify the product of its hypergenesis.

Using microscopy, we have compared microcline in the rocks that are in different phases of weathering and classified the hydrolysis in the process of chemical weathering according to the following phases:

- **Argillization:** the surface of the feldspar in this phase is “dirty” compared to the clean surface of fresh feldspar. The secondary minerals are of very small size, and it is difficult to determine their composition.
- **Illite:** In this phase, there are bright, minute minerals inside the feldspar. Given that the interference colors are of a high order, we have identified them as illite.
- **Kaolinite:** Here the crystal of feldspar has completely weathered into kaolinite, or just a very small amount of it still remains.

When the feldspar has been weathered into illite, kaolinite, and other clay minerals, the mechanical strength of the rock decreases and the power of the destructive expansion of the soluble salt crystals increases. Inevitably, the stone carvings are eroded or weathered.

Conclusion

Water has played an important part in the weathering of the stone carvings at the Yungang Grottoes. All types of deterioration, including loss of stone fragments and cracks, are more or less caused by the mechanical effects of the water-rock reaction.

In terms of water-mediated chemical weathering, the following reactions are important: the solution of carbonate cement, the hydrolysis of sedimentary rock, and the transformation of iron oxide and iron hydroxide minerals. Such reactions decrease the mechanical strength of the stone and result in weathering.

The problem of severe water erosion at Yungang has led to concern from national and international scholars and the Chinese government. Currently, a conservation project to prevent water erosion impact has started, and a comprehensive survey has been completed.

A preliminary plan of water exclusion applied to the area above the caves has been discussed several times by experts. The final plan is in process; in the near future, implementation of the project will minimize the impact of water erosion and greatly slow the deterioration of the Yungang cave temples.

A Chinese-German Cooperative Project for the Preservation of the Cultural Heritage of Shaanxi Province: Conservation of the Polychrome Clay Sculpture and Investigation of Painting Materials in the Great Hall of the Shuilu'an Buddhist Temple

Catharina Blaensdorf and Ma Tao

Abstract: *The Shuilu'an Buddhist temple complex is located near the city of Lantian in Shaanxi province, about 60 kilometers west of the provincial capital, Xi'an. The temple may date to the Tang dynasty (618–907 C.E.) or even earlier, to the Sui dynasty (581–618 C.E.). Of the three original structures (halls) in the complex, the one known as the Great Hall, or Shuilu Hall, has always been the focal point of the temple. The walls of Shuilu Hall are decorated with more than a thousand clay figures, including sculptures of Buddhas and bodhisattvas, and lively relief scenes that include architecture, animals, and nature. The sculptures and reliefs are of high artistic quality and retain their original polychromy. For more than one 150 years, water had penetrated through the leaky roof of Shuilu Hall, creating voids in the walls, detaching the clay sculptures and reliefs, and eroding surfaces. Although prior repairs and renovations were carried out, the continued detachment of sculptures and reliefs is a conservation challenge. An increase in both tourism and religious life in the region has brought more attention to the temple complex, making conservation more imperative.*

In 2000 an agreement was reached between the Bavarian State Department of Historical Monuments and the Xi'an Center for the Conservation and Restoration of Cultural Property of Shaanxi Province to conserve Shuilu Hall. The Chinese-German cooperative program, which ended in late 2002, included research on the hall's art history, materials analyses, and tests for the conservation of the clay reliefs and sculptures. This paper presents results on the history of Shuilu Hall and its construction, the modeling and painting tech-

niques used for the clay sculptures and reliefs, the materials used, and the conservation tests and interventions conducted.

Shuilu'an is a Buddhist temple complex that dates to the Tang dynasty (618–907 C.E.) or even earlier, to the Sui dynasty (581–618 C.E.). The temple complex was built on an island in the Qing River, at the foot of the Wangshun Mountains, about 10 kilometers from the city of Lantian in Shaanxi province and about 60 kilometers west of the provincial capital, Xi'an.

The temple complex consists of three original buildings (halls) arranged in a line, flanked by secondary buildings (fig. 1). The entire complex is enclosed within walls. The history of the temple's construction is not completely settled. Although the foundation and early buildings might date to the Tang or Sui dynasty, legend has it that between 1563 and 1568 C.E., during the Ming dynasty, a prince renovated the temple for his family's use as a sacrifice hall. However, an inscription inside the temple names Qing Houli from Lantian as the initiator and benefactor of this renovation. No other records mention the prince or the local donor.

From the temple's entrance, which was added twenty years ago, one reaches the front hall (empty today) and then the middle hall, which was refurbished in 1981 with a clay sculpture of the Buddha Mile fo and wall paintings. Behind this hall lies the Great Hall, or Zhu sheng shui lu dian (Water-Earth Hall of All Saints). This Great Hall, referred to here as Shuilu Hall, has always been the focal point of the temple.



FIGURE 1 Shuilu'an Buddhist temple complex, Shaanxi province. Credit: A. Borchert, University of Heidelberg, 2001

Iconography and History of Shuilu Hall

The walls of Shuilu Hall are covered with exquisite displays of polychrome clay sculpture consisting of complicated scenes in relief, as well as three-dimensional figures, from a few cen-

timeters to 1.6 meters high. The hall also houses twelve larger-than-life-size sculptures of Buddhas and bodhisattvas.

Figure 2 shows the layout of Shuilu Hall, whose entrance faces east. As in many temples, the hall is divided into a larger main section in the front and a smaller rear section by a freestanding middle wall that spans about two-thirds the width of the hall and by two short wall projections. This construction allows worshipers to walk in procession around the middle wall, which is the center of the temple and contains the most important religious images.

Main Section

In front of the middle wall are three large Buddha sculptures representing the “Three Great Teachers” (*san da shi*): Yaoshi fo (Buddha of healing), Sakyamuni (historical Buddha), and Amitabha (Buddha of infinite light). Four additional large Buddha and bodhisattva sculptures are positioned in the corners of the main section: Yaowang pusa (bodhisattva Baisajyaguru, at the southern wall projection), Dizang pusa (bodhisattva Ksitigarba, at the northern wall projection), Yingshen fo (Buddha, at the southern part of the east wall), and Baoshen fo (Buddha, at the northern part of the east wall).

FIGURE 2 Shuilu'an Buddhist temple complex, Shaanxi province. Credit: A. Borchert, University of Heidelberg, 2001

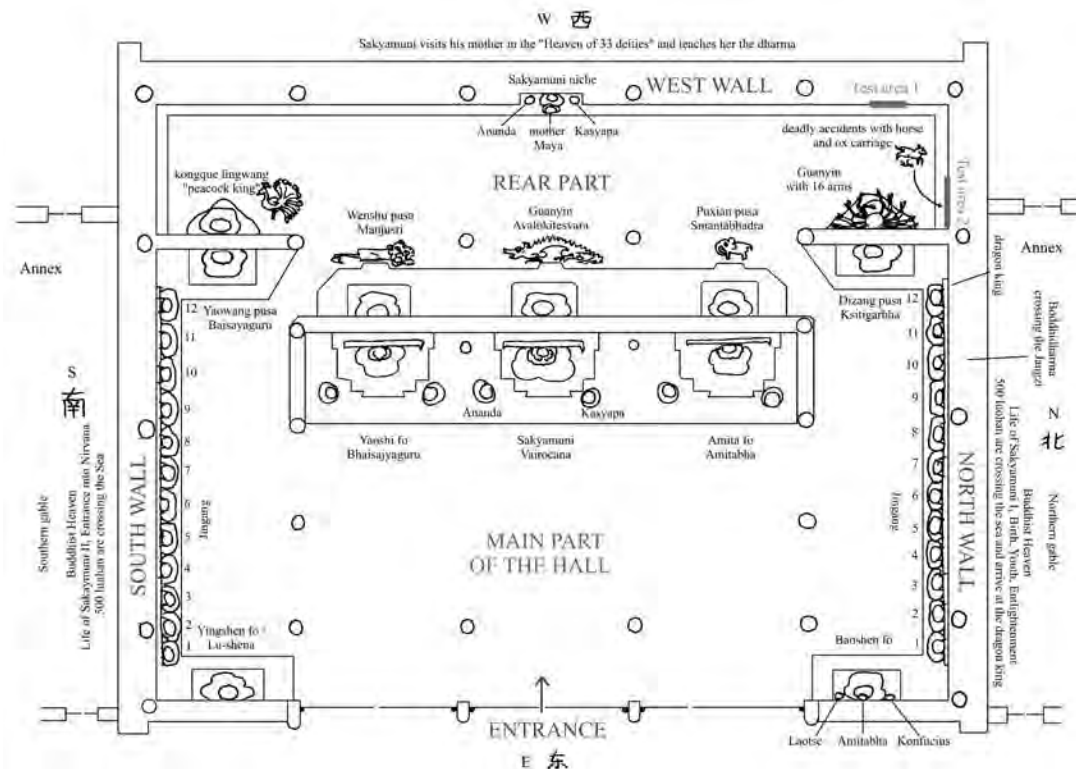



FIGURE 3 Elaborate clay relief on north wall of Shuilu Hall depicting birth and youth of Sakyamuni. Credit: S. Scheder, Bayerisches Landesamt für Denkmalpflege München, 2002

The north and south walls are gabled and decorated with numerous artistic representations arranged on four levels. Along the bottom of each wall there are twelve life-size sculptures of *jingang* (protective deities) from 140 to 160 centimeters high. These sculptures are connected to the wall at their backs. Above them is a relief depicting five hundred *luohan* (enlightened beings) crossing the sea and visiting the Dragon King. Above this scene are large, elaborate reliefs showing the eight stages in the life of Sakyamuni, starting on the north wall with his birth and youth (fig. 3) and steps to his enlightenment and continuing on the south wall with his entrance into nirvana; the central scene depicts mourning disciples at his deathbed. The triangular upper areas of the walls are filled with reliefs showing scenes of Buddhist heaven.

Rear Section

The rear section of Shuilu Hall contains five large bodhisattva sculptures: the three along the rear-facing side of the free-standing middle wall are Puxian pusa (bodhisattva Smantabhadra on an elephant), Guanyin (bodhisattva Avalo-

kitesvara on a dragon), and Wenshu pusa (bodhisattva Manjusri on a white lion). The two sculptures against the short wall projections extending out from the north and south sides of the hall are, respectively, the sixteen-armed Guanyin and the Peacock King (*konque lingwang*, a gold-skinned deity riding a peacock). The reliefs on the west wall and parts of the north and south walls depict “Sakyamuni in the Heaven of the 33 Deities.” This scene focuses on a central niche in the west wall showing Sakyamuni’s mother kneeling in front of him, surrounded by about three hundred sculptures arranged in four tiers.

The Shuilu Rite

Shuilu refers to the “Water-Land” rite that arose in the tenth century and still exists today. The ceremony is performed to plead for the remission of sins of the deceased, especially those who were not buried in an appropriate way. It is a syncretic ceremony in which the deities of Confucianism, Buddhism, and Daoism and popular beliefs are invoked. Two scenes in Shuilu Hall relate to this rite. The first scene appears above the head of the large Baoshen Buddha flanking the entrance on the north side, where there are three small sculptures of Confucius, the Buddha Amitabha, and Laotse (founder of Daoism), thus assembling the three main religions/philosophies of China. The second scene, a relief near the northwest corner, depicts brutal accidents: a man is trampled by a horse, and another is run over by the wheels of an oxcart. Scenes of deadly accidents are often shown in the context of the Shuilu rite, which involves praying for the unhappy souls of accident victims.

The Chinese-German Cooperative Project to Protect Shuilu Hall

Since 1988, when the Chinese-German Cooperative Project for the Preservation of the Cultural Heritage of Shaanxi Province began, Shuilu Hall had been discussed as a possible site for a joint conservation effort. Consideration of such a project was based on the exquisite quality of the clay reliefs and sculptures, the rareness of this technique in Shaanxi province, and the endangered condition of Shuilu Hall. At that time, the temple complex was located in a military district, cut off from public access and attention and therefore almost forgotten.

Early Repair Efforts

For more than 150 years, water had penetrated through the leaky roof of Shuilu Hall. Rainwater ran down the wooden

pillars, creating voids in the walls, detaching the clay sculptures, and eroding surfaces. This resulted in severe damage to areas below the roof and in the corners.

Starting in the early twentieth century, large-scale repairs and renovations of Shuilu Hall were undertaken. New walls of fired brick were constructed around the building (1919) to protect the original clay walls against further weathering, and the roof was repaired several times (1959 and 1981–85). During the repair campaigns of 1981–85, the clay reliefs were secured by steel anchoring. Many endangered figures in the upper parts of the walls next to the roof were removed at that time and subsequently reattached, although some figures on the west wall were attached in the wrong places. The clay walls on the east side of the hall, flanking the entrance doors, were demolished and rebuilt using fired bricks. The reliefs on these walls were secured to the roof beams with wire. The original small windows in the west wall were sealed; two openings were then cut into the east and west corners of the building, and ventilators were installed to decrease humidity in the summer.

In 1990 the fragile situation became evident when a large part of the peacock feather mandorla behind the head of the Peacock King sculpture collapsed due to vibrations from a passing airplane. In 1994 a report on the situation was compiled by the Xi'an Center for the Conservation and Restoration of Cultural Property of Shaanxi Province (Fan Juan 1994). This report became the basis for all future investigations and conservation measures. Basic work to stabilize the building was carried out until 1997. Today Shuilu Hall appears stable. The roof is watertight, and existing cracks have not become larger over the years. The climatic conditions are fairly stable.

In 1998 the site where the temple complex is located was no longer designated a military zone, and a road was built, allowing public access. Since then the temple complex has enjoyed a revival, culminating in the construction of a new hall in front of the entrance hall that is used for praying and where at least one monk lives. An increase in both tourism and religious life in the region resulted—bringing more attention to the temple complex but also making conservation more imperative.

The Chinese-German Conservation Campaign

In 2000 an agreement was made between the Bavarian State Department of Historical Monuments and the Xi'an Center for the Conservation and Restoration of Cultural Property of

Shaanxi Province to cooperate in the research and conservation of Shuilu Hall. The agreement includes research on art history, materials analyses, and tests for the conservation of the clay reliefs and sculptures. The art historical research comprises the history and religious importance of the temple, the iconography, and the style of the reliefs and sculptures. This includes information on building and renovation phases, artists, donors, and religious activity. Materials analyses served to identify most of the pigments used for the sculpture polychromy. Carbon 14 dating of organic material provided data on the history and prior repairs of the building. The style of the sculptures and reliefs in Shuilu Hall indicate that its interior could have been completed in the 1560s. However, the rear section of the hall is quite different in style and looks rather old-fashioned compared to the animated and complicatedly arranged scenes in the main section. It had been thought that the rear section might be considerably older than the main section and thus spared from the Ming dynasty renovation, but the carbon 14 dating of organic additives in the mortars used in that section do not support this theory.¹

The practical work was carried out during two campaigns of three weeks each: in September–October 2001 and in August 2002. Interventions were carried out on two test areas to determine the best methods for conserving two detached figures and a deformed, partially detached relief, as well as the walls behind them. **In preparation for the conservation tests**, the German-Chinese research team made maps of Shuilu Hall based on drawings and digital photographs to document in detail the extent of earlier repairs, the methods applied, and the materials used (some of which, such as concrete, were completely inappropriate). The team examined existing damage to the walls and to the at-risk sculpture. With the help of a video-borescope, they also examined conditions inside the walls. During this initial investigation and documentation of the entire wall space in Shuilu Hall, the team determined that there are 1,372 figures.

Building Technique of Shuilu Hall

Shuilu Hall is a classical construction with wooden pillars and walls, about 30 centimeters thick, made of clay and clay bricks. The lower part of the walls up to a height of 150 centimeters is made of rammed earth; the upper part of the walls is built with air-dried clay bricks. The bricks are spaced a few centimeters apart and are connected only with small amounts of mortar between them.

The walls have a 2-centimeter-thick rough cast surface made of clay mortar containing much straw and chaff. This

building technique has been used for many centuries in this region and can still be seen on old houses in Xi'an and in the countryside.

Modeling Technique used for Clay Sculptures and Reliefs in Shuilu Hall

The exquisite display of Buddhist clay sculpture in Shuilu Hall dates from the Ming dynasty, providing rare examples of this technique in Shaanxi province. Clay sculptures and reliefs are often found in Buddhist contexts. The works in Shuilu Hall show a high level of skill in sculpting and painting and were executed with a classical clay modeling technique.

A number of important temples with clay sculptures and reliefs are located in Shanxi, the province northeast of Shaanxi, some dating to the Tang dynasty (ca. 800 C.E.). These early temples have only sculptures and sometimes painted walls, but temples from the Ming dynasty often have clay reliefs covering the walls completely or in part. In this context, an inscription on the pedestal of the main sculpture of Sakyamuni in Shuilu Hall is interesting. It reads:

Qiao Zhongchao, master of Buddhist sculptures from Shanxi [province], together with four men, has made these reliefs.

Although no record of the artist has been found, this inscription indicates that the technique and the style used in Shuilu Hall indeed came from the neighboring province of Shanxi.

Modeling sculptures in clay is a very old technique in China, described as early as 90 B.C.E. in the *Shiji* (The Grand Scribe's Record) by Sima Qian. The technique has remained relatively unchanged since then and includes the following:

1. wooden support structure;
2. hemp rope or strings wound around the wooden support to provide an attachment surface for the clay;
3. rough modeling layer with clay containing straw;
4. finely detailed modeling;
5. fine clay finish containing fibers such as hemp, silk, or cotton;
6. partial or complete paper coating followed by white primer and sizing;
7. application of decorative *pastiglia* (in Chinese, *lifan*)² and gilding; and
8. painting of the sculpture.



FIGURE 4 Severely damaged clay figure showing internal support structure. Credit: S. Wallner, Bayerisches Landesamt für Denkmalpflege München, 2001

This technique was also used in Shuilu Hall. All sculptures and reliefs were modeled in place in the temple. Dowels attached the art to the walls. The dowels were inserted at an oblique angle to keep the sculpture in position by its own weight, even if the dowel loosened to a certain degree.

The support structure inside the sculptures and reliefs is made of bamboo sticks or wood. For the smaller figures (up to about 50 cm high), the support often consists of only one or two vertical bamboo sticks for the body (fig. 4), with small twigs inside the forearms and wrists. The larger figures, up to about 5 meters high, have a more complicated support structure of wooden sticks and panels, reed, and wire that forms a more or less detailed outline of the sculpture. Long parts of figures such as fluttering scarves, strands of hair, or decorations on headwear are supported by a wire core. Reed bundles form the internal support for architecture and landscape reliefs.

A rough modeling layer was applied over the support structure and consisted of a coarse clay with the same composition as the clay mortar (clay with chaff and straw) on

the walls. The fine clay finish (about 3–5 mm thick) contains hemp fibers as well as sand. It was applied on the sculptures and the walls at the same time, so the same material covers all surfaces of Shuilu Hall.

Some smaller elements that were needed in large quantities were made using molds and attached with clay slip. This technique was used for such ornamental elements as clouds, railings, and roof tiles of pavilions, as well as for the faces of the smaller wall sculptures such as those on the west wall.

The clay modeling in Shuilu hall is very fine and shows detailed structures even on the smallest figurines. The fine clay finish is adapted to what will be depicted; for example, it is very smooth in preparation for architectural scenes but sandy and rough where landscapes or clouds were planned.

The twenty-four life-size *jingang* possess black glass eyes. Today all these glass eyes are broken, but several that are held in the palms of the sixteen-armed Guanyin have survived intact.

Painting Technique

The dominant colors used on the Shuilu Hall sculpture are green, red, white, and gold, often in sharp contrast. Walls, reliefs, and sculptures were painted at the same time, so the polychromy of the sculptures is the same as that of background scenes painted as murals. The polychromy is carefully applied down to the smallest details. The smallest figurines and elements (a few centimeters tall) are finely painted, even if they are barely visible.

Preparatory Layers. These started with a sizing layer, possibly of animal glue, followed by a white ground layer and another thin layer of sizing. The white ground layer consists of a white earth (the main component is muscovite mica, not kaolinite). The ground layer was grayed with charcoal black when used for painted landscapes. Joints in the modeling were covered with thin strips of paper before or during addition of the ground.

Underpainting. These preliminary paint layers were colored according to the color of the final coat. For example, gray underpainting was used for a final coat of blue, light green for greens, or orange for red. Underdrawings of orange and green demarcated areas of different color.

Overpainting. The final colors were translucent and applied in several layers, thus making them increasingly opaque with each additional layer, a technique similar to watercolor painting. The effect of this technique is highly visible on the multicolored trimmings of robes, where at

least four layers were applied, making the color darker and brighter with each layer.

Binding Medium. The binding medium has not yet been identified. The paint layers today appear matte and are highly sensitive to water, so an aqueous binding medium such as plant gum or animal glue might have been used for both the primer and the colors.

Pigments. The pigments identified so far are white earth (in robes, architecture, clouds); a mixture of lead white and shell white (in white lines and faces); cinnabar, often with an underpainting of minium (red lead); hematite and orpiment (to create brown colors); atacamite; indigo; and charcoal black. Pink consists of white earth mixed with red iron oxide when used for clouds or garments but mixed with cinnabar when used for faces.

Special colors in this palette are the greens and the blues. Instead of malachite and azurite, the pigments normally used for these colors, atacamite and indigo were found. The atacamite is artificial, as seen in its morphology. The indigo was extended with natural chalk, a material that was not found in any other place in Shuilu Hall.

Gilding. Gilding was applied with an aqueous medium and was not burnished. On smaller decorations, gold leaf cut into tiny squares, often only 5 by 5 millimeters, was applied. In contrast to the usual order of creating traditional Chinese clay sculpture, this gilding was executed after the painting.

Decoration Techniques. For decorations on garments with flower or geometric patterns, different techniques were used. The garments of the larger sculptures are decorated with elaborate patterns of painted or gilded *pastiglia*. *Pastiglia* and painted decorations are often combined (fig. 5). On the pedestals of the large Buddhas, very fine clay decorations made in molds were used instead of *pastiglia*. Four small scenes of flying cranes and landscapes were created in fine gold *sgraffiti*.³

Mordant gilding, in which a sticky, viscose material was used to adhere gold leaf to the paint layer, was used for geometrical decorations on the robes of smaller figures.

Conservation Challenges of Shuilu Hall

The biggest conservation problem for Shuilu Hall is the continued detachment of sculptures and reliefs, especially from the west wall and the adjacent parts of the north and south walls. The sculptures and relief sections tilt away from the wall under their own weight. The dowels attaching the sculptures and reliefs to the walls are pulled into a horizontal

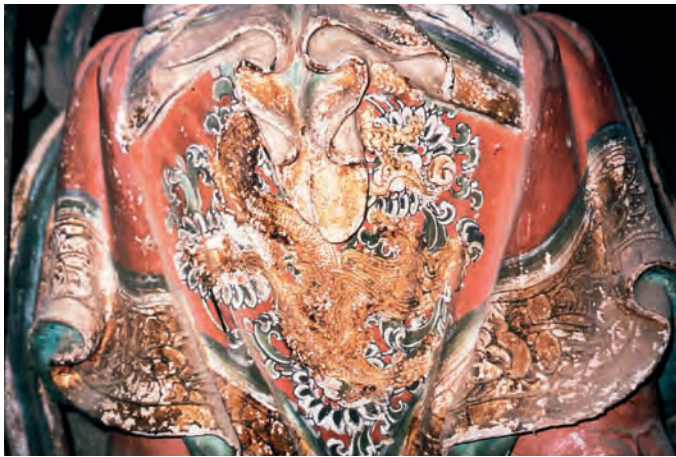

FIGURE 5 Gilded *pastiglia* dragon and painted flowers on the robe of a *jingang* sculpture. Credit: S. Wallner, Bayerisches Landesamt für Denkmalpflege München, 2001

position and can no longer hold up the art. Some reliefs have deformed considerably because of this process. On the west wall, in particular, many of the figures, about 50 centimeters high and weighing 3 kilograms, now hang only at the tip of a single dowel. Consequently, the figures tend to fall from the walls. Temporary fixes—for example, securing the sculpture

with wire attached to nails in the wall—are not sufficient and are visually objectionable (fig. 6).

The visual appearance of the walls is especially affected by surface damage. Parts of the wall sculptures are severely eroded by water or are missing completely. Water damage has caused the paint layer to lose its cohesion and turn into powder. Heads, small figures, and parts of architecture are often missing in areas that were easily reachable by visitors, before barriers were installed. All surfaces are covered with dust, a problem that has increased because of the added ventilation system. The ventilators draw in dusty air from the courtyard. There are screens in front of the ventilators to exclude birds, but these are not fine enough to prevent the entrance of dust. The areas below the ventilators are especially dusty.

Many white painted areas, especially in faces, appear slightly gray today due to discoloration of the lead white in the paint layers caused by sulfur from the air. Interestingly, minium (red lead), which as a lead oxide can also be affected by sulfur, does not show any recognizable changes.

Conservation Tests

The Chinese-German team began work on Shuilu Hall in 2001. Two test areas were selected for conservation in the northwest corner to be representative of the severer damage (see fig. 2).



FIGURE 6 Test area 1 prior to conservation, showing two detached clay figures held in place by wire and nails. Credit: S. Scheder, Bayerisches Landesamt für Denkmalpflege München



FIGURE 7 Test area 1 after conservation. Credit: C. Blaensdorf, Bayerisches Landesamt für Denkmalpflege München



FIGURE 8 Test area 2: "Deadly accident" relief after conservation. Credit: Technical Center for Conservation, Xi'an, China

Test area 1 consists of two figures detaching from the west wall; they were held in place by only a few nails and wires as the dowels had completely loosened from the wall. Figure 6 shows these figures before conservation; figure 7 shows them after conservation. One detached sculpture was used for tests to stabilize the clay layers.⁴

Test area 2 was the relief of the "deadly accident" scenes described earlier. This is a large relief, measuring about 2 square meters (fig. 8).

The two test areas were used to determine the best methods for the following:

- cleaning the surfaces;
- consolidating the powdery paint layers;
- removing poorly or erroneously attached sculptures from the walls;
- repairing the walls behind the reliefs and sculptures;
- structurally stabilizing the wooden support structure and clay layers of the figures;
- resecuring the sculptures or reliefs to the walls; and
- completing missing pieces of the clay sculpture (only if necessary for their stabilization).

Conservation Interventions

The primary goal of the conservation effort was to keep interventions to a minimum and to stabilize the walls and sculptures in their current condition. The following describes the initial actions taken for the two test areas.

Paint Layer. After several tests with different adhesives, the surface of the paint layers was dry-cleaned and consolidated with polyvinyl alcohol (Mowitol 4-88; 2% and 5% diluted with water).

Clay Layers of Walls and Sculpture. The best results for stabilizing the clay layers and grouting voids were achieved by applying the same type of material that had been used for the fine clay finish. This consisted of clay from local deposits mixed with hemp paper and sand.⁵ Grouting was used for the smaller voids inside the wall in test area 1.

Deformed Clay Relief. The deformed “deadly accident” relief in test area 2 was no longer in contact with the eroded wall; it was standing on a ledge along its lower edge and was partially attached to another relief along its upper edge. Behind the lower part of the deformed relief, the gap measured about 6 centimeters. Investigations with the video-borescope showed that the dowels originally used to attach the relief had slipped out of the wall and, unable to carry the relief’s weight, had broken off. After a long discussion, it was decided to remove the deformed relief. This is a highly invasive action, and it is not planned on a larger scale for the rest of Shuilu hall. The detached relief was reshaped into its original form by placing it facedown on a soft but stable support and moistening the back side. The moisture softened the relief slightly so that it straightened out under its own weight. After the wall had been stabilized and a new layer of clay mortar applied, the relief was reattached. Two years later, no new damage has occurred, except for recent layers of dust covering the surfaces.

Conclusion

The exemplary conservation work done in Shuilu Hall, executed in two campaigns of only three weeks each, demonstrates that conservation of the entire hall will be possible with promising results at a rather low cost. Although the reliefs and sculptures in Shuilu Hall are fragile in places and minor areas cannot be reconstructed, the building is stable and important parts of sculptures and reliefs are still preserved and can be rescued. Thus it is still possible

to understand the temple’s special iconographic program, that is, its imagery or symbolism, associated with tantric Buddhism in relation to the syncretic Shuilu rite, and to enjoy its artistic quality.

The Chinese-German conservation effort concluded in late 2002, when funding from Germany ended. During winter 2002–3, seven more figures at risk of falling had to be removed from the walls. This illustrates the dangerous situation of the sculpture in Shuilu Hall and the urgency of the conservation work. The Xi’an Center for the Conservation and Restoration of Cultural Property of Shaanxi Province has applied for financial support from the Shaanxi Cultural Relics Bureau for the conservation of the entire Shuilu’an temple complex. We hope to find a way to continue this urgent task.

Acknowledgments

The authors wish to extend special thanks to Director Hou Weidong and Yang Qi of the Xi’an Center for the Conservation and Restoration of Cultural Property of Shaanxi Province; to Fan Juan, formerly with the Technical Center; and to Rolf Snethlage, of Bayerisches Landesamt für Denkmalpflege, head of the German side of the project. We also wish to thank Zhang Xiaorong, Liu Linxi, Yang Qiuying, and Dang Xiaojuan of the Xi’an Center for the Conservation and Restoration of Cultural Property of Shaanxi Province, all of whom worked on the conservation campaign. Zhen Gang, photographer at the Xi’an Center for the Conservation and Restoration of Cultural Property of Shaanxi Province, provided the first professional detailed photographs of the reliefs. Siegfried Scheder, freelance conservator from Ochsenfurt, carried out the practical work, from mapping to conservation, in the Shuilu’an temple complex, along with student assistant Stephanie Wallner. Vojislav Tucic and Rupert Utz, of Bayerisches Landesamt für Denkmalpflege, conducted additional analyses; Angelika Borchert, of the University of Heidelberg, Department of East Asian Research, researched the Shuilu’an temple complex’s history and iconography and the Shuilu rite as part of her Ph.D. dissertation; Lucien Van Valen, with the Research School of Asian, African, and Amer-Indian Studies, Leiden, contributed additional information on painting techniques and materials.

Notes

- 1 The results of seventeen samples indicate a date between 1440 and 1630 C.E. (except for one sample from the west wall dated at 1030–1380). The ¹⁴C-AMS (accelerator mass spectrometry) dating was done by Gerhard Morgenroth, University of Erlangen, Germany, and Georges Bonani, Institute for Particle Physics, Swiss Federal Institute of Technology (ETH), Zurich.
- 2 *Pastiglia* are raised decorations made by the application of a priming material on the white primer or between priming layers. The composition of the decoration material is different from the primer and usually is white, ocher yellow, or reddish.
- 3 *Sgraffito* is a method for creating a design by incising one layer of color to reveal another color underneath. To create the scenes of flying cranes and landscapes, a plain area was first gilded and burnished and then covered with a translucent paint layer. A fine pointed tool was used to scratch off the color in the desired design, creating a golden scene on a colored background.

- 4 The sculpture had been stored in the office of the temple director, and its original location in the hall was not recorded.
- 5 Following a recipe provided by local workers, a layer of clay mixed with water was placed in a bucket and covered with a layer of paper made of hemp. This was followed by several more layers of clay and paper as well as sand. After twenty-four hours, the contents of the bucket were stirred, causing the paper to separate into fibers.

References

- Fan Juan. 1994. Shaanxi sheng Lantian Shuilu'an, nizhi caihui bisu fenghua jilu ji jia gu jishu yanqiong (Studies on the weathering mechanisms of the painted clay sculptures in Shuilu'an temple). Internal report in Chinese. Partial translation into German in the Bayerisches Landesamt für Denkmalpflege, Munich.
- Sima Qian. 1936. *Shiji (The Grand Scribe's Record) ca. 90 B.C.E.* Shanghai: Shang wu yin shu guan.

Two Methods for the Conservation of the Polychromy of the Terracotta Army of Qin Shihuang: Electron Beam Polymerization of Methacrylic Monomers and Consolidation Using Polyethylene Glycol

Daniela Bathelt and Heinz Langhals

Abstract: *The life-size sculptures of the Terracotta Army of the first Chinese emperor, Qin Shihuang, are among the most famous archaeological monuments in the world. The site, located in Lintong, about 45 kilometers northeast of Xi'an, is still being excavated. Rows of soldiers are on display in the site museum. The sculptures, gray-brown in color, originally were painted vividly, then buried for 2,200 years in humid soil. Soon after excavation and exposure to a dry environment, the polychromy of the terracotta sculptures flaked off rapidly as water was lost from the ground layer, which is made of East Asian qi-lacquer. For this reason, after excavation and before conservation begins on other terracotta pieces, the objects are maintained in a humid environment to prevent detachment of the paint layer. Our project concerns the development and testing of special conservation methods to preserve the polychromy of the Terracotta Army. This work is being carried out in both Germany and China.*

The problem facing conservation of the terracotta figures is stabilizing the lacquer layer in such a way that it no longer shrinks when it loses water. None of the substances usually used for restoration give positive results. This paper discusses two new strategies that have been developed for conserving the polychromy: polyethylene glycol (PEG) consolidation and electron beam polymerization of 2-hydroxyethyl methacrylate (HEMA). Both PEG consolidation and electron beam polymerization have proven capability to serve the conservation needs of the Terracotta Army. Both have clear advantages, but each also has room for improvement.

The Terracotta Army is among the most famous archaeological monuments in the world and one of China's greatest tourist attractions. Almost everyone has seen pictures of

the rows of life-size soldiers, gray-brown in color, like the earth around them (figs. 1, 2). But it is not well known that



FIGURE 1 View of the Terracotta Army in pit no. 1.



FIGURE 2 Colored kneeling archers in pit no. 2.

these figures were originally painted vividly; the colors were lost after the figures were excavated (Rogner et al. 2001). This paper discusses the problem encountered in trying to preserve the polychromy on other terracotta figures and the solutions we have developed.

The Terracotta Army

When the Terracotta Army was discovered on March 29, 1974, in Lintong, about 45 kilometers northeast of Xi'an, it quickly became a sensation. Approximately eight thousand life-size terracotta warriors and horses had been entombed in four pits about 1.5 kilometers from the tomb of the first emperor of China, Qin Shihuang (259–210 B.C.E.). The Terracotta Army is said to protect the “city” of the “sleeping emperor,” whose mausoleum has not yet been excavated. There are about one hundred other pits in the burial complex, containing not only terracotta figures but also life-size horses, weapons, carriages, and birds made of bronze and armor carved out of limestone. In 1987 UNESCO added the Terracotta Army and the Tomb of the First Qin Emperor to the World Heritage List.

When the emperor died, the burial complex was pilaged. The weapons of the terracotta warriors were stolen, and the underground wooden structures that protected the warriors were set on fire. The structures collapsed, burying the figures in water-saturated soil for two millennia and creating challenges for the conservation of the polychromy on the figures.

Polychromy

Structure

As shown in figure 3, the polychromy on the terracotta figures consists of

- a base, or ground, of qi-lacquer (Kryo-SEM [scanning electron microscopy] clearly shows that the qi-lacquer was applied as a double layer, each layer 20 microns [μm] thick; fig. 4); and
- a pigment layer. The binding media could not be identified.

Although analysis has not identified an isolation layer below the base, this third layer must have existed to prevent the qi-lacquer from penetrating the terracotta.

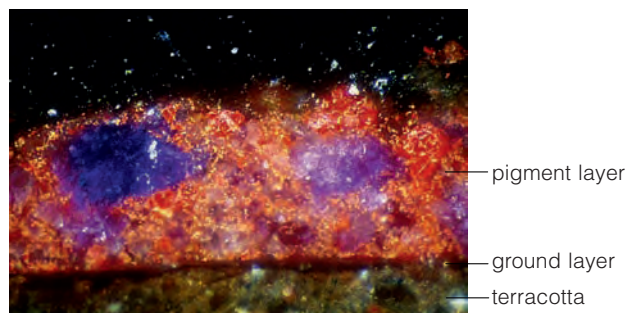

FIGURE 3 Polychromy structure.

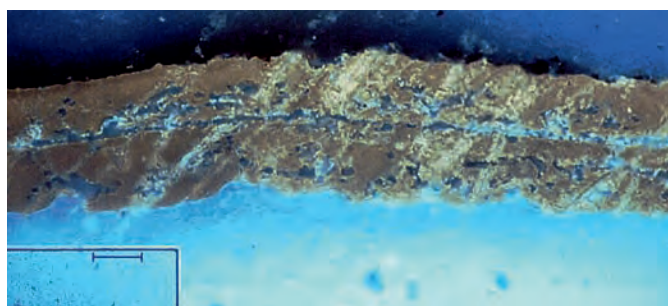

FIGURE 4 Double layer of qi-lacquer ground.

Qi-lacquer is a hydrophobic material (Thieme et al. 1995) obtained from the East Asian lacquer tree *Toxicodendron vernicifluum*. In addition to water, the main components of the raw material are polysaccharides, glycoproteins, and benzcatechin derivatives, which polymerize to form a black lacquer.

The painted figures of the Terracotta Army had been buried for 2,200 years in damp soil. As long as the figures are kept in a humid environment, water remains incorporated in the lacquer layer. But after excavation and exposure to a dry environment, the lacquer quickly loses water (fig. 5). This layer soon shrinks, develops a detailed cracking pattern, shows deformation, loses its adhesion to the terracotta, and falls off.

If flaking occurs, conservation is problematic; there is no satisfactory way to reattach the detached layers to the terracotta. For this reason, after excavation of new pieces and before conservation begins, the objects are maintained in a saturated atmosphere—100 percent relative humidity (% RH)—to prevent detachment of the paint layer.

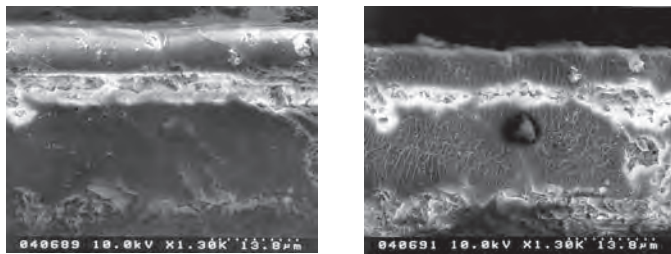

FIGURE 5 Kryo-SEM images of the qi-lacquer ground saturated with water (left) and dry (right).

Stabilization and Consolidation

In order to conserve the terracotta figures, the lacquer layer must be stabilized in such a way that it no longer shrinks when it loses water. Previous conservation attempts and analysis of the lacquer's structure indicate that the lacquer layer can be stabilized by substituting a hydrophilic consolidant for the water in the lacquer. This substitution must be undertaken in several steps, with increasing concentration of the consolidant. If the substitution is done too quickly, cracks form.

The material used as consolidant and adhesive has to have good long-term stability and be at least partially reversible. Further, it must tolerate seasonal climate changes (winter, down to 2°C, as low as 20% RH; summer, up to 37°C, as high as 85% RH) since the exhibition halls where the Terracotta Army is on display are not climate controlled to museum conditions.

Our group tried many times to find a way to stabilize and consolidate the lacquer, but none of the substances usually used for restoration gave positive results. Two new possibilities have been developed to conserve the polychromy: PEG consolidation and electron beam polymerization.

PEG Consolidation

PEG consolidation uses short-chain polyethylene glycol 200 (PEG-200), which is well known for conserving waterlogged wood. The PEG-200 consolidant is applied as a poultice in three steps to slowly substitute for 30, 60, and 80 percent of the water in the lacquer base. Each step takes two days. An adhesive dispersion is added in the first step to stabilize the layer. We have used a polyurethane dispersion, which shows good adhesion. For better long-term stability, however, a polyacrylate dispersion should be used.

Electron Beam Polymerization

With electron beam polymerization, one substance takes over the tasks of stabilization and consolidation. The object being treated is first soaked in a monomer that replaces the water in the lacquer layer. Afterward the object is irradiated by an electron beam. The irradiation creates free radicals of the monomers, which start a chain reaction that builds up the polymer in situ, at the important interface between the terracotta and the lacquer. As with PEG consolidation, a poultice is used to apply the monomer in three steps for 30, 60, and 80 percent water substitution. Each step lasts at least forty-eight hours.

The monomer used for this method has to be highly miscible with water and, on irradiation, form a polymer with a low glass transition point and good aging characteristics. A monomer that has these properties and has already been used to conserve waterlogged materials is 2-hydroxyethyl methacrylate, a derivative of methacrylic acid (Rogner 2000). With its OH-function, it is very hydrophilic. HEMA is miscible with water in any ratio, has a glass transition temperature of about 11°C, and has acceptable aging properties. For these reasons, HEMA was used for initial tests to stabilize the polychromy.

Polymerization can be initiated once the final concentration of monomer in the object has reached 80 percent. Various techniques were considered, but most of them failed:

- UV/visible light of any wavelength cannot penetrate the black lacquer.
- X-rays and γ -rays either damage the terracotta or do not generate enough radicals (Rogner 2000).
- High temperature damages the lacquer.

Molecular radical initiators cannot be applied at the interface between lacquer and terracotta. The only possibility left is electron beam irradiation. The accelerated electrons can penetrate the terracotta down to about 2 millimeters. They generate reactive radicals of the HEMA monomer, which themselves react with other monomers to form a relatively homogeneous polymer that stabilizes and consolidates the polychromy (fig. 6). The polymerization takes place mainly in the upper layer of the terracotta, where the electrons are absorbed, and it does not cause any side reactions with the pigments, which remain stable during irradiation (Barcellona Vero et al. 1976; Bathelt 2002; Serra 1972).

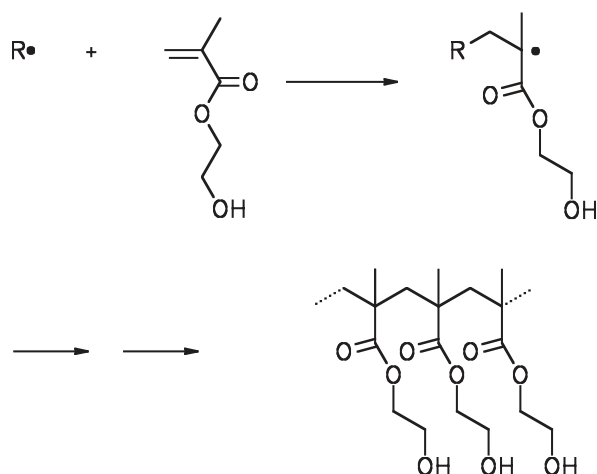

FIGURE 6 Polymerization reaction of HEMA.

HEMA itself does not form a sufficiently adhesive polymer in the terracotta. Therefore, a polyfunctional monomer has to be added to the mixture to cause cross-linking in the polymer. The cross-linking inhibits migration of the polymer and effects better adhesion of the polychromy to the terracotta.

For the cross-linking agent, polyethylene glycol dimethacrylate 550 (PEG-DMA 550) was used. During the first attempts at cross-linking, a high ratio of PEG-DMA 550 (15 w% of acrylate in the aqueous consolidation mixture) was used. This high ratio resulted in a highly brittle polymer that is sensitive to environmental changes. Therefore, the ratio of cross-linking agent was reduced.

Not all the monomer molecules in the consolidant are polymerized by electron beam irradiation. Most of them are still unreacted after irradiation and remain in the terracotta. HEMA evaporates after a while, but PEG-DMA 550 does not. This kind of cross-linking agent remains in the terracotta and undergoes delayed polymerization via metal catalysis, mostly promoted by copper-containing pigments. The copper-containing pigments used for the statues in the Terracotta Army are Han purple, $BaCuSi_2O_6$; malachite, $Cu_2CO_3(OH)_2$; and azurite, $Cu_3(CO)_3(OH)_2$.

Metal-catalyzed polymerization, especially with copper-containing pigments, produces shiny spots on the surface of the polychromy. The spots emerge months after treatment; they are soft in the beginning and become harder with time. Fourier transform infrared spectroscopy reveals that the spots consist of polymerized PEG-DMA.

To avoid these effects, the cross-linking monomer has been changed to a shorter chain: ethylene glycol dimethacrylate (EG-DMA). EG-DMA is able to cross-link HEMA in a way similar to that of PEG-DMA, and it evaporates more easily at normal room climate. In contrast to PEG-DMA, EG-DMA is applied in a lower ratio, producing a less rigid polymer. In this way, it should be possible to avoid shiny spots.

Physical Setup for Electron Beam Polymerization

Electron beam polymerization is easily done, but it requires access to an electron beam facility, which is not usually available. Fortunately, we have access to one at the Institute for Polymer Research in Dresden, Germany, as well as at the Xi'an Radiation Research Center in Lintong, China.

At the Dresden facility, the object to be irradiated is placed on a tray that passes through several shielding gates on its way to the outlet of the electron accelerator. Electrons are generated in a vacuum by a heated cathode, and the emitted electrons are accelerated in an electrostatic field applied between cathode and anode. Acceleration takes place between the cathode, which is at high negative voltage potential, and the grounded accelerator vessel (anode). The energy gain of the electrons is proportional to the accelerating high voltage. After moving past the outlet of the accelerator, the tray passes through several additional shielding gates to the exit. The shielding is necessary because of the X-rays (Bremsstrahlung) that are generated during the production of the electron beam. One should also be aware of the large amount of ozone that is a by-product.

Electron beam polymerization was developed in cooperation with the Institute of Polymer Research in Dresden, where an ELV-2, INP Novosibirsk accelerator is used. The energy of the electron beam at the Dresden facility can be varied between 0.6 million electron volts (MeV) and 1.5 MeV; the maximum current is 25 milliamps (mA). This polymerization method has also been adapted to the ELV-8, INP Novosibirsk accelerator used at the Lintong facility.

To determine the best irradiation values to use for treating an object, the following parameters have to be taken into account:

- the distance from the tray to the outlet of the accelerator, since oxygen in the air slows down accelerated electrons; and
- the electron beam radiation dose, since heat develops in the object and increases enormously with increasing dose.

Various tests showed that the best values for irradiating objects are 1 MeV, 2 mA, and 60 kGy (radiation dose). At a dose lower than 60 kGy, the polymer does not harden enough to consolidate. At a higher dose, the heat generation is so high that the polychromy becomes seriously damaged.

Conclusion

Both PEG consolidation and electron beam polymerization have proven capability to serve the conservation needs of the Terracotta Army. Both have clear advantages, but each also has room for improvement.

Electron Beam Polymerization. Objects treated with this method retain what was probably the original matte appearance of the pigments. However, cracks and shiny spots have developed in the polychromy of some treated objects. Further research is needed to improve the resulting polymer, for example, by using a shorter chain cross-linker such as EG-DMA. In addition, it will be necessary to build a device to treat round objects under the electron beam.

PEG Consolidation. This treatment can be applied in situ, while objects are still in the pit immediately after excavation, as well as on objects that already show damage from drying. Treated objects do not develop cracks and shiny spots, but they look much darker after treatment and stay wet. Their appearance is duller than with electron beam polymerization, and they tend to attract dust.

Acknowledgments

The authors would like to thank Wu Yongqi, Zhou Tie, Zhang Zhijun, Rong Bo, Xia Yin, and Zhang Shangxin of the Museum of the Terracotta Army of Qin Shihuang, Lintong, Shaanxi, China; Ingo Rogner, Cristina Thieme, Christoph Herm, and Rupert Utz, former coworkers on the China Project at the Bavarian State Department of Historical Monuments, Munich, Germany; Sandra Bucher, Felix Horn, Catharina Blänsdorf, and Rolf Snethlage, current coworkers on the China Project at the Bavarian State Department of Historical Monuments, Munich, Germany; Herbert Juling of MPA Bremen, Germany; Gerd Gülker, Arne Kraft, and Akram El Jarad of the University of Oldenburg, Germany; and BMBF for financial support.

References

- Barcellona Vero, L., G. Magaudo, Rota Rossi-Doria, and M. Tabasso Laurenzi. 1976. Radiosterilizzazione di tavole dipinte: Azione sui microrganismi ed effetti collaterali sulla colla di coniglio e su alcuni pigmenti. In *International Conference, Applications of Nuclear Methods in the Field of Works of Art (Rome-Venice, 24–29 May 1973) = Congresso internazionale, applicazione dei metodi nucleari nel campo delle opere d'arte (Roma-Venezia, 24–29 maggio 1973)*, ed. R. Cesareo. Atti dei convegni lincei. no. 11. Roma: Accademia nazionale dei Lincei.
- Bathelt, D. 2002. *Forschungsbericht 2001–2002 des Projektes “Eprobrung und Optimierung der Konservierungstechnologien für Kunst- und Kulturgüter der Provinz Shaanxi, VR China” = Work Report of 2001 and 2002 for the “Project Testing and Optimising of Conservation Technologies for the Preservation of Cultural Heritage of the Shaanxi Province, PR China.”* Munich: Bayerisches Landesamt für Denkmalpflege.
- Rogner, I. 2000. Festigung und Erhaltung der polychromen Qi-Lackschichten der Terrakottakrieger des Qin Shihuangdi durch Behandlung mit Methacryl-Monomeren und Elektronenbestrahlung (Teil 1): Untersuchungen zu Synthese der 6,6'-Bis (diorganyl amino)-oxindigos (Teil 2). Ph.D. dissertation, Ludwig-Maximilians-Universität München. http://edoc.ub.uni-muenchen.de/309/1/Rogner_Ingo.pdf.
- Rogner, I., H. Langhals, Zhou Tie, Zhang Zhijun, Rong Bo, and C. Herm. 2001. Consolidation and preservation of the polychrome qi-lacquer layers of the Terracotta Army of Qin Shihuang by treatment with methacrylic monomers and electron beam curing. In *Die Terrakottaarmee des ersten chinesischen Kaisers Qin Shihuang = The Terracotta Army of the First Chinese Emperor = Qin Shihuang ling bingmayong*, ed. C. Blänsdorf, E. Emmerling, and M. Petzet, 594–617. Arbeitshefte des Bayerischen Landesamtes für Denkmalpflege, vol. 8. Munich: Bayerisches Landesamt für Denkmalpflege.
- Serra, M. 1972. Controllo dei colori sottoposti a radiazioni gamma. *Quaderno de la Ricerca Scientifica* 81: 50–54.
- Thieme, C., E. Emmerling, C. Herm, Wu Yongqi, Zhou Tie, and Zhang Zhijun. 1995. Research on paint materials, paint techniques and conservation experiments on the polychrome Terracotta Army of the first emperor Qin Shi Huang. In *The Ceramics Cultural Heritage: Proceedings of the International Symposium, The Ceramics Heritage, of the 8th CIMTEC—World Ceramics Congress and Forum on New Materials, Florence, Italy, June 28–July 2, 1994*, ed. P. Vincenzini, 591–601. Monographs in Materials and Society, no. 2. Faenza: Techna.

The Stone Armor from the Burial Complex of Qin Shihuang in Lintong, China: Methodology for Excavation, Restoration, and Conservation, including the Use of Cyclododecane, a Volatile Temporary Consolidant

Sandra Bucher and Xia Yin

Abstract: In 1998 more than eighty sets of ceremonial stone armor, including forty helmets for soldiers and horses, were discovered near the mausoleum at Lintong of Qin Shihuang, the first Chinese emperor, through the systematic work of Chinese archaeologists. The armor was made from limestone plates connected with bronze wires. The material showed a wide spectrum of conditions. Some parts were well preserved; others were severely damaged by a fire set during the succeeding dynasty.

In May 2000 a Chinese-German partnership between the Museum of the Terracotta Warriors and Horses in Lintong and the Bavarian State Department of Historical Monuments in Munich began to investigate ways to preserve the stone armor. The limestone and the bronze were analyzed by instrumental techniques. In addition, petrographic analyses determined water uptake, and tensile strength and porosity of the armor were measured. The investigations yielded information about production techniques, materials used, conditions of the materials, and the decay process affecting the stone plates and its physical and chemical causes. Based on these results, a conservation plan is being developed for the armor.

A new method was tested for preventing the deterioration of the material during excavation. With the use of cyclododecane (CDD), a volatile binding medium, as a reversible consolidant, good results were achieved. CDD has been used in conservation mainly for stabilizing wall paintings. More recently, it was adopted for use in the conservation of archaeological objects. This paper reports the successful removal of a complete set of armor using CDD.

In 1998 Chinese archaeologists systematically exploring a 120-square-meter area near the mausoleum of Qin Shihuang,

the first Chinese emperor, made a spectacular discovery: about eighty sets of ceremonial body armor for warriors, including forty helmets, as well as armor for horses, all made of small limestone plates. The stone armor was discovered in a burial chamber in the southeast section of the mausoleum, 1.5 kilometers west of the Terracotta Army.

Each set of armor consists of at least six hundred individual small limestone plates connected with bronze wire in a highly complicated system that allowed the armor to move (fig. 1). Although life-size, this armor was never intended for use. Rather, it represents copies of real armor that was made of iron or leather, and the different types vary in design in accordance with a warrior's rank. The two main types of armor were (a) copies of leather armor made with rectangular plates and (b) copies of metal armor whose plates resembled fish scales (Sheng kao gu yan jiu suo and Qin shi huang bing ma yong bo wu guan 2006: 271).

The current situation in the excavation pit is very complex. The sets of armor lie on top of one another in several layers (fig. 2). In some places the individual plates are still connected; in other places they lie in jumbled disorder. The result resembles 80 different puzzles, each with about 600 pieces thrown together in a pile. Some sets of armor are well preserved; others were severely damaged by a fire set during the succeeding dynasty.

It is unclear how the armor and the helmets were originally displayed in the pit. Based on the position of the plates today, it is surmised that the armor was hung from the ceiling of the burial chamber. However, nothing is preserved of any wooden substructure, if one existed.

In May 2000 a team of Chinese and German researchers, representing a partnership between the Museum of the



FIGURE 1 Set of stone body armor and helmet. Reproduced by permission of the Museum of the Terracotta Warriors and Horses of Qin Shihuang, Lintong, China

Terracotta Warriors and Horses in Lintong and the Bavarian State Department of Historical Monuments in Munich, began a project to investigate ways to preserve the stone armor. During the course of this study, numerous analyses were conducted to determine the characteristics of the limestone and the bronze. The materials were analyzed in cross section and thin section using X-ray fluorescence, X-ray diffraction, infrared spectroscopy, mass spectrometry, and optical emission spectroscopy. In addition, specific petrographic analyses were conducted to determine water uptake



FIGURE 2 Current condition of stone armor in the excavation pit. Reproduced by permission of the Museum of the Terracotta Warriors and Horses of Qin Shihuang, Lintong, China

and tensile strength. Ultrasonic and porosity measurements (by mercury intrusion) were made to determine damage caused by the fire. The investigations yielded fundamental information about the production techniques and materials used for the stone armor, the condition of the materials, and the physical and chemical alterations experienced by some of the armor during the fire (Bucher and Weichert 2002; Langhals, Bathelt, and Bucher 2005). Based on these results, a conservation treatment plan is being developed.

Stone Armor Production Techniques

To produce the stone armor, craftsmen sawed and split many thousands of individual plates from a dark limestone, filing and polishing them into perfect form. The majority of the plates are rectangular in shape and measure approximately 5 by 4 by 0.5 centimeters. There are also square, trapezoidal, scaled, and irregular shapes.

Recently, tools that were used to produce the limestone armor were found in a well from the Qin period close to the grave site. With the tools were several unfinished or broken limestone plates, probably discarded waste material. Various sandstone grinding and polishing stones used to

treat the surfaces of the plates were also found. The discovery of tools, as well as traces of the workmanship left on the stone plates, documents that making the armor was a laborious undertaking.

Connecting Wires

A clay mold was discovered that provides insight into how the bronze connecting wires were made. The mold, approximately 10 centimeters long and 4 centimeters in diameter, is perforated along its length. The holes are close together, and their cross section reveals the square shape and size of the original wires. Thus it seems likely that the wires were cast and mass produced at almost industrialized speed, not drawn, as was usual in Europe. Metallurgical investigations of the cross sections of the wires, using a scanning electron microscope, reveal the typical crystal form of cast metal.

Drilling Technique

In order to be connected with one another, each of the armor plates had to be drilled through several times. Technical aspects of this drilling technique were investigated, including the form and material of the drill point, the abrasiveness of the drill, the optimal pressure placed on the drill, and the kind of supports used during drilling. The relevant literature, substantiated by scientific investigations, leads to the conclusion that a spiral hand drill was used on the limestone plates. X-ray diffraction of a metal particle discovered in one of the drill holes identified it as iron, thus suggesting that the holes were made with an iron drill. Practical experiments with a spiral hand drill showed that a maximum of three minutes were necessary to drill one hole. Based on this rate, and the fact that each plate contains between six and fourteen holes, we calculated that about 350 working hours were needed merely to drill the holes in the plates for a single set of armor.

Condition of the Stone Armor

The armor and helmets not affected by the fire are astonishingly well preserved, whereas the damage to those pieces exposed to the fire is disastrous. The affected limestone plates, originally dark gray, had turned white as the bituminous component of the stone escaped when the temperature from the fire reached 600°C.

Initially the limestone was chemically altered into calcium oxide. Then, in combination with air and moisture from the ground, this was slaked to calcium hydroxide (lime). All

phases of the chemical alteration of the limestone were documented through X-ray diffraction, thin section analysis, and scanning electron microscopy.

When the pit was opened, the fire-damaged plates initially displayed their original shape. However, once in contact with air, within some weeks the plates recarbonated and swelled to about nine times their volume. They became severely cracked and friable. Many plates decomposed completely into powder.

The bronze connecting wires of the fire-damaged plates were also corroded. Some of them were broken, or they had become so deformed that in some parts of the pit the armor can no longer be put back together.

Restoring the Stone Armor

After the condition of individual armor plates and wires was documented, attention turned to removing and conserving the armor.

Removal

The stone armor was fragile, even those pieces not burned, and its removal from the pit posed a special challenge. During initial salvage efforts, it was not possible to remove a complete set of armor together with its bronze connecting wires. Instead, the wires had to be cut and removed, and then the plates were individually extracted from the ground and reconnected using new wires. Unfortunately, cutting the wires irretrievably lost precious original material, and removing the plates individually lost important information concerning their production. Some other way had to be found to remove the armor intact, without altering the arrangement of the individual plates.

To avoid future losses, trials were conducted using cyclododecane (CDD) as a reversible consolidant. CDD is a nonpolar hydrocarbon compound that is solid at room temperature. It melts at 58–61°C, and it can be applied as a liquid to an object, after which it solidifies quickly into a waxlike coating. Its high vapor pressure causes it to sublime at ambient temperature (20–23°C) at a rate of 4.5 milligrams per day, leaving practically no trace behind, thus making it particularly gentle for use on fragile objects (Geller and Hiby 2002: 15).

Because of its special properties, CDD has been increasingly used in the restoration field. The material has been successfully used to temporarily stabilize fragile objects, from sculpture to wall paintings, during transport



FIGURE 3 Close-up of cyclododecane-coated stone armor plates with lifting straps. Reproduced by permission of the Bavarian State Department of Historical Monuments, Munich, Germany

and consolidation (Brückle et al. 1999; Hangleiter 1998; Hiby 1999; Scharff and Huesmann 1998; Stein et al. 2000). CDD is also used as a hydrophobic coating. Only recently has the material been used, on a limited basis, to remove archaeological objects safely.

Cyclododecane Trials

An initial experiment was conducted in 2002 to stabilize a section of armor containing about one hundred plates with CDD. A hot wax gun was used to spray the material onto the armor. The resulting waxlike layer, about 3 millimeters thick, held the individual plates and their connecting wires together, and the entire section was removed from the ground using attached straps (fig. 3). After the CDD evaporates (the time can be shortened significantly by raising the room temperature and increasing air circulation), restoration work can be undertaken.

This was the first time that CDD had been used to remove an interconnected armor segment in preparation for conservation. Because a CDD coating is weak, however, it has a tendency to break. This posed a risk for the removal of a complete set of armor, which weighs about 20 kilograms. For this reason, further improvements in the procedure were sought, and a new method was tested.

After a series of tests using an exact dummy of a set of armor, a new salvage experiment was initiated in summer



FIGURE 4 Brush application of cyclododecane over cotton gauze on test section of armor. Reproduced by permission of the Bavarian State Department of Historical Monuments, Munich, Germany

2004 on an intact segment of armor. The individual steps of the operation, described below, were more complicated than those of the initial experiment, but this guaranteed that the weight of a complete set of armor could be removed without any problem.

- *Step 1:* The melted cyclododecane was mixed with 10 percent of heptane, thus making it possible to apply it with a brush. The cyclododecane was applied to several layers of cotton gauze placed over the armor (fig. 4). This produced a solid protective layer.
- *Step 2:* After a wait of about twenty-four hours to be sure that the heptane had evaporated, the treated armor was encircled with a cardboard frame. This was filled with a layer of polyurethane foam, about 10 centimeters thick, and a wooden reinforcement grid and lifting straps were embedded in the foam (figs. 5, 6).
- *Step 3:* After the foam hardened completely, it was possible to raise the unit out of the ground with the lifting straps. The armor released cleanly from the ground without leaving behind any pieces. Turning the unit upside down revealed the side of the armor that originally had been faced down on the ground (fig. 7).



FIGURE 5 Removal unit with wooden reinforcement grid and lifting straps before addition of polyurethane foam. Reproduced by permission of the Bavarian State Department of Historical Monuments, Munich, Germany



FIGURE 6 Removal unit with lifting straps embedded in polyurethane foam. Reproduced by permission of the Bavarian State Department of Historical Monuments, Munich, Germany



FIGURE 7 Underside of removal unit, revealing intact armor plates. Reproduced by permission of the Bavarian State Department of Historical Monuments, Munich, Germany

Cleaning

The exposed stone plates and wires were carefully cleaned, and any loose stone elements were glued in place with polybutyl-methylacrylate (Mowital B30 H15).¹ After cleaning, a plastic layer was applied over the exposed armor and a negative mold of the surface was made out of gypsum plaster, making it possible to turn over the armor. The plaster layer then became a support. Next, the polyurethane foam and layers of CDD-impregnated cotton gauze, now on top, were removed. This removal was done with a bath of heptane that penetrated the gauze and dissolved the CDD. The now-loosened fabric and foam were removed, revealing the side of the armor that had been faceup on the ground. Now this side could be cleaned. The restored test section of armor is shown in figure 8.

Promise for the Future

The promising results using CDD-based stabilization to salvage a test section of stone armor meant that researchers could confidently proceed with the removal of a complete set of armor. In May 2005 we did so, successfully lifting and transporting a complete set of armor from the burial pit to the conservation workshop, where it will be restored



FIGURE 8 Restored test section of stone armor. Reproduced by permission of the Bavarian State Department of Historical Monuments, Munich, Germany

and prepared for exposition to the general public. The final plans for the ceremonial stone armor of Emperor Qin's army include construction of a museum around the pit where the armor was found. This museum will join the Terracotta Army museum and other excavations at the site of Qin's mausoleum, providing scientists and visitors with the opportunity to see the armor in its historical context.

Acknowledgments

The authors extend special thanks to Yang Mangmang, Archaeological Institute of Shaanxi Province, Xi'an, China; Wang Dongfeng, Wang Weifeng, and Li Hua, Museum of the Terracotta Warriors and Horses of Qin Shihuang, Lintong, China, for their help during excavation; German conservator Hans Hangleiter and trainee Leonie Salzmann for ideas about a more stable excavation method and for help in conducting one of the project tests; Vojislav Tucic, Bavarian State Department of Historical Monuments, Munich, and Herbert Juling, Materialprüfanstalt, Bremen, for metal and stone analysis; and Maya Weichert, conservator and former member of the team, for her contributions to the work and for conducting one of the project tests.

Materials List

Cyclododecane
 Dr. Georg Kremer, Dipl.-Chemiker, Farbmühle
 Hauptstrasse 41-47, D-88317 Aichstetten/Allgäu
 Tel. + 49 (0)7565-1011 oder - 91120; Fax + 49 (0)7565-1606
 e-mail: kremer-pigmente@t-online.de

Kremer Pigments, Inc.
 228 Elizabeth Street
 New York, NY
 Tel. + 1 212 219 2394; Fax. + 1 212 219 2395
 e-mail: kremerinc@aol.com

Mowital B30 H15
 Clariant (Germany) GmbH
 Wiesentalstrasse 27
 Postfach 2280
 D-79512 Lörrach, Germany
 Tel. + 49 7621 417 0; Fax + 49 7621 417 150

Notes

- 1 Mowital B30 H15 was used for gluing, instead of Paraloid® B72, because of its higher glass transition temperature (65°C). In summer, the temperature in Lintong can quickly rise above 40°C, and in the past this has led to problems with Paraloid®. The material becomes soft and sticky, with severely diminished adhesion, and particles of dirt remain stuck to objects. Tests of Mowital's bonding strength on limestone produced sufficiently good results.

References

- Archaeological work report of the mausoleum of Qin Shihuang. 2000. Archaeological Institute of Shaanxi Province and the Museum of the Terracotta Warriors and Horses, Beijing.
- Brückle, I., J. Thornton, K. Nichols, and G. Strickler. 1999. Cyclododecane: Technical note on some uses in paper and objects conservation. *Journal of the American Institute for Conservation* 38 (2): 162-75.
- Bucher, S., and M. Weichert. 2002. Konservierung und Restaurierung der Kalksteinpanzer = Analysis of deterioration processes of the burnt limestone plates. In *Forschungsbericht 2001-2002 des Projektes "Eprobung und Optimierung der Konservierungstechnologien für Kunst- und Kulturgüter der Provinz Shaanxi, VR China" = Work Report of 2001 and 2002 for the "Project Testing and Optimising of Conservation Technologies for the Preservation of Cultural Heritage of the Shaanxi Province, PR China,"* 112-30. Munich: Bayerisches Landesamt für Denkmalpflege.

- Geller, B., and G. Hiby. 2000. *Flüchtige Bindemittel in der Papierrestaurierung sowie Gemälde- und Skulpturenrestaurierung*. Kölner Beiträge zur Restaurierung und Konservierung von Kunst- und Kulturgut, no. 10. Munich: Siegl.
- Hangleiter, H. M. 1998. Erfahrungen mit flüchtigen Bindemitteln. Teil 2: Vorübergehende Verfestigung, schützende oder verdämmende Versiegelung von Oberflächen an Gemälden, Stein oder Wandmalereien. *Restauro* 7: 468–73.
- Hiby, G. 1999. Cyclododecan als temporäre Transportsicherung: Materialeigenschaften des flüchtigen Bindemittels bei Bild- und Fassungsschichten. *Restauro* 5: 358–63.
- Langhals, H., D. Bathelt, and S. Bucher. 2005. The tomb of the first Chinese emperor: A challenge for conservation = Das Grabmal des ersten chinesischen Kaisers: Eine konservatorische Herausforderung. *Chemie in Unserer Zeit* 39 (3): 196–211.
- Scharff, W., and I. Huesmann. 1998. Conservation of archaeological metal artifacts: Thermal treatment methods for iron objects and temporary consolidation of fragile corrosion products with volatile binders. In *Metal 98: Proceedings of the International Conference on Metals Conservation = Actes de la conférence internationale sur la conservation des métaux: Draguignan-Figanières, France, 27–29 May 1998*, ed. W. Mourey and L. Robbiola, 155–61. London: James & James.
- Shaanxi Sheng kao gu yan jiu suo and Qin shi huang bing ma yong bo wu guan. 2006. *Qin shi huang di ling yuan kao gu bao gao (2000) = Report on Archaeological Researches of the Qin Shihuang Mausoleum Precinct in 2000*. Ed. Di 1 ban. Beijing: Wen wu chu ban she.
- Stein, R., J. Kimmel, M. Marincola, and F. Klemm. 2000. Observations on cyclododecane as a temporary consolidant for stone. *Journal of the American Institute for Conservation* 39 (3): 355–69.

The Development of Ancient Synthetic Copper-Based Blue and Purple Pigments

Heinz Berke, Armin Portmann, Soraya Bouherour, Ferdinand Wild, Ma Qinglin, and Hans-Georg Wiedemann

Abstract: Mineral sources for stable blue and purple pigments were rare in antiquity. Efforts to improve availability of such pigments began more than five thousand years ago, in predynastic Egypt, with the synthesis of Egyptian blue, a defined chemical compound of the composition $\text{CaCuSi}_4\text{O}_{10}$. This synthetic pigment became widespread, and archeometric studies have shown that it was definitely used in the Mesopotamian, Greek, and Roman civilizations.

In China, where the lack of mineral blue pigments also became a challenge, the synthetic pigments Chinese blue and purple, also known as Han blue and purple, were developed. It is known that they existed by the late Western Zhou dynasty, around 800 B.C.E. Artifacts containing Chinese blue or purple that we have investigated so far include beads, earrings, and octagonal sticks. These pigments were also found in pigment layers of the Terracotta Army from the Qin dynasty (221–207 B.C.E.) and on wall paintings of Han dynasty tombs (206 B.C.E.–220 C.E.). In two beads we studied, ultramarine blue was found along with Chinese blue or purple. It is plausible that the ultramarine blue was of synthetic and not mineral origin (from lapis lazuli). Chinese blue and purple are even more complex than Egyptian blue, and their production is more sophisticated because of the higher temperatures required and the need to carefully control component quantities and the physical conditions of the synthesis. These difficulties, along with the chemical similarities to Egyptian blue, suggest that the Chinese pigments were likely to have been improvements on the Egyptian predecessor rather than independent developments. The question remains as to how knowledge about Egyptian blue spread to China. A technology transfer might have occurred along the Silk Road, but this is a matter to be addressed by future archeometric studies.

Colors had great meaning to people in prehistoric times and in antiquity. Earth colors were readily available as they could be obtained directly from soil. Some colors, such as blue and purple, however, depended on mineral sources that were exceptionally rare in antiquity and not always accessible. Lapis lazuli and azurite were the main pigment minerals for blue color as well as for purple,¹ which was achieved by mixing blue pigment with red (iron oxides, vermilion). Azurite is quite abundant but not very stable, whereas lapis lazuli, which was highly valued in antiquity, is rare and restricted in use. Thus, although earth colors were used in prehistoric cave paintings (Ball 2001), blue colors are strikingly absent. Later civilizations, even highly developed ones, also suffered from frequent shortages of stable blue pigments, and this probably accounted for their high idealistic and materialistic esteem. This situation did not change until the nineteenth century, when industrialization led to the chemical mass production of dyes and pigments.

The limited availability and stability of natural blue pigments in antiquity presumably stimulated the invention of appropriate synthetic materials. The Egyptians created Egyptian blue, the Chinese invented Chinese (or Han) blue and purple, and the Maya synthesized Maya blue (Chiari, Giustetto, and Ricchiardi 2003: 21–33). Various civilizations also made a blue pigment (smalt) by grinding cobalt-containing glass and glazes (Berke 2004: 401–5). The different types of ancient man-made blues and purple are listed in table 1 together with their chemical compositions and brief historical data.

This paper focuses on the chemical development of the important synthetic pigments of antiquity: Egyptian blue, Chinese blue, and Chinese purple (Berke 2002). These

Table 1 Compilation of Various Synthetic Blue and Purple Pigments Produced in Antiquity (Berke 2004: 401–5)

Name	Composition	Material Type	Approximate Time of Appearance
Egyptian blue	$\text{CaCuSi}_4\text{O}_{10}$	Alkaline-earth copper silicate	3600 B.C.E.
Smalt (cobalt blue)	$\text{CoO}(\text{SiO}_2)_n$	Cobalt oxide in a glass matrix	1000 B.C.E.
Chinese (Han) blue	$\text{BaCuSi}_4\text{O}_{10}$	Alkaline-earth copper silicate	800 B.C.E.
Chinese (Han) purple	$\text{BaCuSi}_2\text{O}_6$	Alkaline-earth copper silicate	800 B.C.E.
Ultramarine blue	$\text{Na}_{0.9}[\text{Al}_{5.6}\text{Si}_{6.4}\text{O}_{24}]\text{S}_{2.0}$	Sodalite cages filled with S_n^-	800 B.C.E.
Maya blue	$(\text{C}_{16}\text{H}_{10}\text{N}_2\text{O}_2)_y \cdot [(\text{Mg},\text{Al})_4\text{Si}_8(\text{O},\text{OH},\text{H}_2\text{O})_{24}]_m \cdot x \text{H}_2\text{O}$	Indigo as a host molecule in white clay	400 B.C.E.

pigments were developed through complex experimentation based on a related alkaline-earth copper silicate chemistry (*alkaline-earth* refers to such elements as calcium and barium). This paper also discusses a recently detected ultramarine blue pigment, which appears to be the serendipitous outcome of experimentation with alkaline-earth copper silicate chemistry in antiquity.

Alkaline-Earth Copper Silicate Pigments

Azurite is an abundant mineral source for natural blue pigment, but the color is not very stable. In antiquity, Egyptians and Chinese learned how to use azurite or another copper mineral as the starting component for the synthesis of stable blue and purple copper silicate pigments.

Egyptian Blue

Egyptian blue is the oldest man-made pigment, developed in predynastic Egypt more than five thousand years ago (Chase 1971: 80–90).

Chemistry. Egyptian blue is a defined chemical compound with the formula $\text{CaCuSi}_4\text{O}_{10}$. Figure 1 is a schematic representation of this pigment's chemical structure.² The copper ions in Egyptian blue function as chromophores (structures that give color to the pigment).

Synthesis. In ancient times, Egyptian blue was prepared by heating ground limestone, quartz (sand), and a copper mineral such as malachite, azurite, kinoite, or even copper metal to 800 to 900°C in the presence of a flux (Bayer and Wiedemann 1976: 20–39). Certain other physical and chemical conditions, such as an excess of air and control over stoichiometric ratios of the starting materials, also had to be satisfied to obtain products of high quality. Apparently ancient Egyptians had knowledge of the necessary ratios for mixing the ingredients, since the various elemental constituents were kept relatively constant over more than two thousand years, as shown in table 2 (Wiedemann and Berke 2001).

Distribution. Egyptian blue became widespread in the Mediterranean region, especially later, during the Greek and Roman civilizations (Riederer 1997: 23–45). It continued to

FIGURE 1 Schematic representation of the silicate sheet framework for both Egyptian blue ($\text{CaCuSi}_4\text{O}_{10}$) and Chinese blue ($\text{BaCuSi}_4\text{O}_{10}$). The calcium (Ca) or barium (Ba) ions are located between layers but are omitted here for clarity. The copper (Cu) ions, which give the pigments their color, are shown in blue. Silicon (Si) is shown in green; oxygen (O), in red.

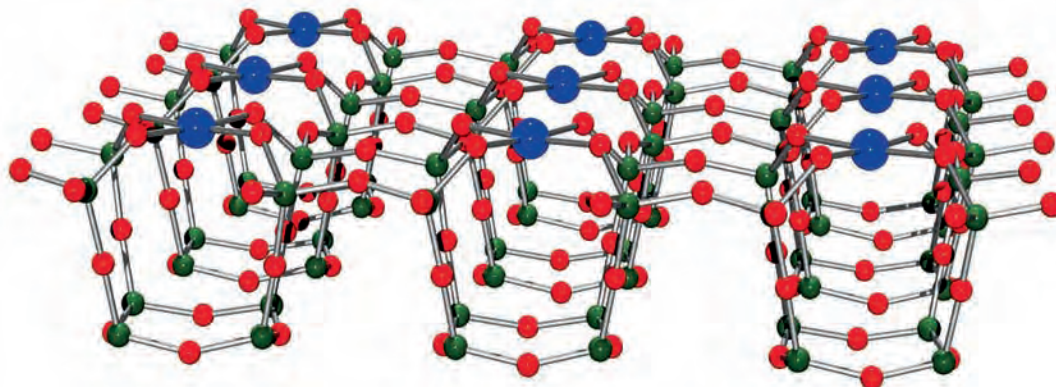

Table 2 Ancient Egyptian Artifacts Containing Egyptian Blue Pigment and Its Respective Elemental Composition (Wiedemann and Berke 1999: 154–70)

Artifact and Location	Dynastic Period	Time	Composition (in oxide percent)		
			Ca	Cu	Si
Mastaba of Mereruka, Saqqara, Egypt	Old Kingdom	2575–2134 B.C.E.	15.2	21.3	63.0
Tomb of Intef*, Thebes, Egypt	Middle Kingdom	2040–1640 B.C.E.	14.9	21.5	63.8
Akhenaten Temple, Talatat Stones, Amarna, Egypt	New Kingdom	1353 B.C.E.	24.0	22.5	53.5
Nefertiti, Berlin, Germany	New Kingdom	1340 B.C.E.	17.4	30.2	52.3
Bes amulet, unknown location	Late Period	712–332 B.C.E.	13.6	28.5	58.3
Mummy coffin, unknown location	Greek-Roman	332 BCE–395 C.E.	18.4	22.5	59.2
Average composition			17.3	24.4	58.4
Theoretical composition			18.6	29.4	52.0

*General Intef, Middle Kingdom, 11th dynasty, reported to Mentuhotep II

spread east into Mesopotamia and Persia. Completing the distribution map of Egyptian blue remains a great challenge. At present it is not certain how far east and north this synthetic pigment spread and whether its geographic distribution also followed the Silk Road into central Asia and the Far East. Any new Egyptian blue finds in these eastern regions could help to establish whether the chemical experimentation that led to the development of Egyptian blue had also influenced the development of the chemically related Chinese blue and purple or if an independent synthesis was found for them. Samples of Egyptian blue as well as Chinese blue and purple made by contemporary synthesis are shown in figure 2. With comparable particle size, Egyptian blue and Chinese blue are nearly identical in color. The pigments appear different in figure 2 because the Chinese blue particles are coarse and the Egyptian blue is finely ground, producing a lighter tone.



FIGURE 2 Left: Egyptian blue ($\text{CaCuSi}_4\text{O}_{10}$); middle: Chinese purple ($\text{BaCuSi}_2\text{O}_6$); right: Chinese blue ($\text{BaCuSi}_4\text{O}_{10}$).

Chinese (Han) Blue and Purple

Chemistry. Chinese blue and purple are distinct chemical compounds with the compositions $\text{BaCuSi}_4\text{O}_{10}$ and $\text{BaCuSi}_2\text{O}_6$, respectively. As alkaline-earth copper silicates, they are closely related chemically to each other and to Egyptian blue. Chinese blue differs very little from Egyptian blue: the calcium in Egyptian blue is replaced by the chemically similar element barium to create Chinese blue. Consequently, Chinese blue has a chemical structure closely related to Egyptian blue and likewise belongs to the class of sheet silicates (see fig. 1).

Although Chinese purple is chemically similar to Chinese blue and Egyptian blue, this pigment has a unique layered structure (Janczak and Kubiak 1992), as shown in figure 3.³ This unique structure gives Chinese purple physical and chemical properties that differ from those of the two blue pigments—not only its purple color, but its lower thermal stability and low chemical resistance to acidic agents.

Synthesis. Chinese blue and purple are more difficult to make than Egyptian blue. These pigments are synthesized at higher temperatures (900–1,000°C)—about 150°C higher than for Egyptian blue. In ancient times, this temperature range was technologically more difficult to achieve. In addition to quartz and a copper starting mineral, a barium source was needed. Barium minerals are generally much less abundant than the limestone used for Egyptian blue, although they are nevertheless common in some areas of China. Either barite (BaSO_4) or witherite (BaCO_3) was used in antiquity, and both

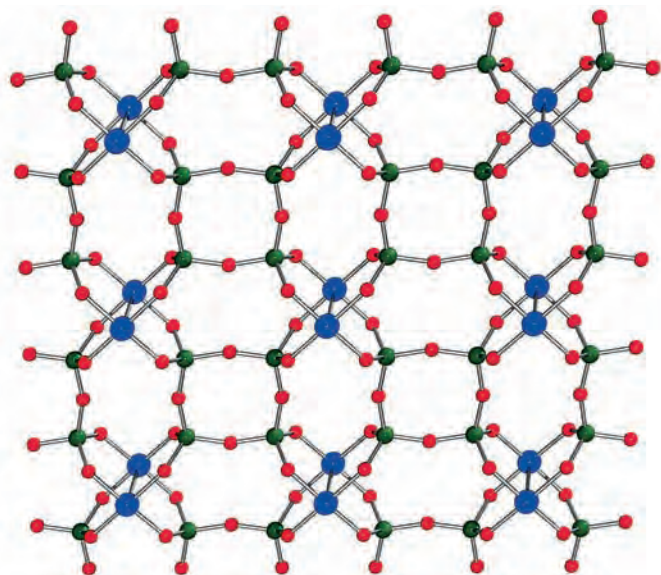

FIGURE 3 Schematic representation of the silicate structure of Chinese purple ($\text{BaCuSi}_2\text{O}_6$). The barium (Ba) ions, which are located between layers, are omitted for clarity. Silicon (Si) is shown in green; oxygen (O), in red; and copper (Cu), in blue.

require comprehensive mineralogical knowledge for their utilization. For example, when the more abundant barite was used, lead salts had to be added to obtain satisfactory pigment qualities. The lead salts had two chemical functions—that of a catalyst to break down the barite and that of a flux. Thus the production of the Chinese pigments was developed based on more sophisticated technologies and was on the whole a more complicated process than that involved in the production of Egyptian blue (Wiedemann and Bayer 1997; Wiedemann, Bayer, and Reller 1997).

Historical Use. Blue pigment played an important role in China's historical development (Ma Qinglin et al. 2001), apparently beginning in the late Western Zhou dynasty, about 800 B.C.E. Whether this date really marks the earliest appearance of Chinese blue and purple is open to speculation. New discoveries are expected from still older archaeological sites, and the earliest date of the historical appearance of the pigment may perhaps be about 900 to 1000 B.C.E. This period would coincide with the beginning of an important technological era in ancient northwestern China.

Samples of Chinese blue and purple that we investigated cover a range of one thousand years of use. The pigments were found in decorative objects, such as glazed blue beads and earrings from the late Western Zhou dynasty

and the Spring and Autumn period of the Eastern Zhou dynasty (800–475 B.C.E.) and octagonal sticks probably used as a commodity for paint applications or decoration from the Warring States period of the Eastern Zhou dynasty (475–221 B.C.E.), from the Qin dynasty (221–207 B.C.E.), and from the Western and Eastern Han dynasties (206 B.C.E.–220 C.E.) (FitzHugh and Zycherman 1983, 1992).

Figure 4 presents a selection of recently studied Chinese objects containing blue and purple pigments from the earlier periods (Ma Qinglin et al. 2006). Bead 1 has a glassy surface containing Chinese purple and ultramarine blue with a white inner core and dated to 777–766 B.C.E. (Dai Chunyang 2000). Bead 2 has a glassy outer layer containing primarily Chinese blue and ultramarine blue with a colored inner core and dated to the eighth–sixth century B.C.E. Both beads were recovered from northwestern China. Bead 3 consists of a heterogeneous compact blue body containing Chinese blue and dated to the sixth–fourth century B.C.E. (Archaeology Team of Baoji City 1993). The octagonal stick is uniformly colored with Chinese purple and consists of partly crystalline, partly vitreous sinter material with high lead and barium content with a weathered whitish outer layer, dated to the fifth–third century B.C.E. (Archaeology Team of Luoyang City 1999; Ma Qinglin et al. 2006; Zibo Museum 1997).

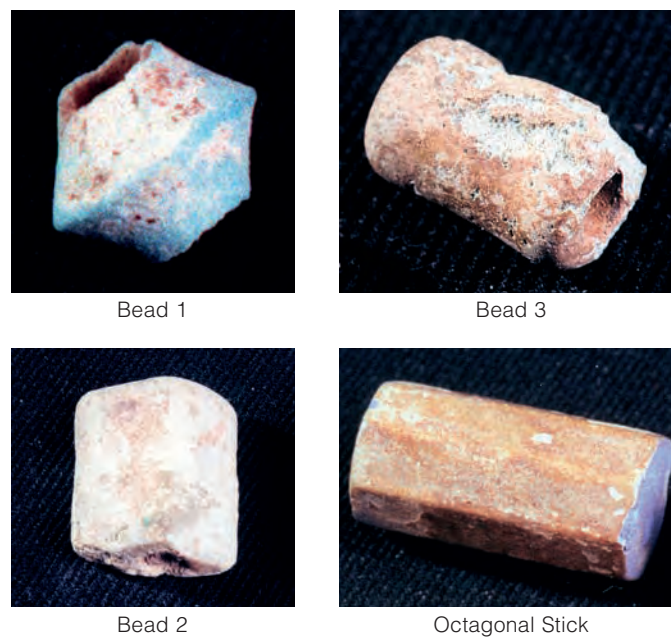

FIGURE 4 Chinese artifacts containing synthetic blue and purple pigments.

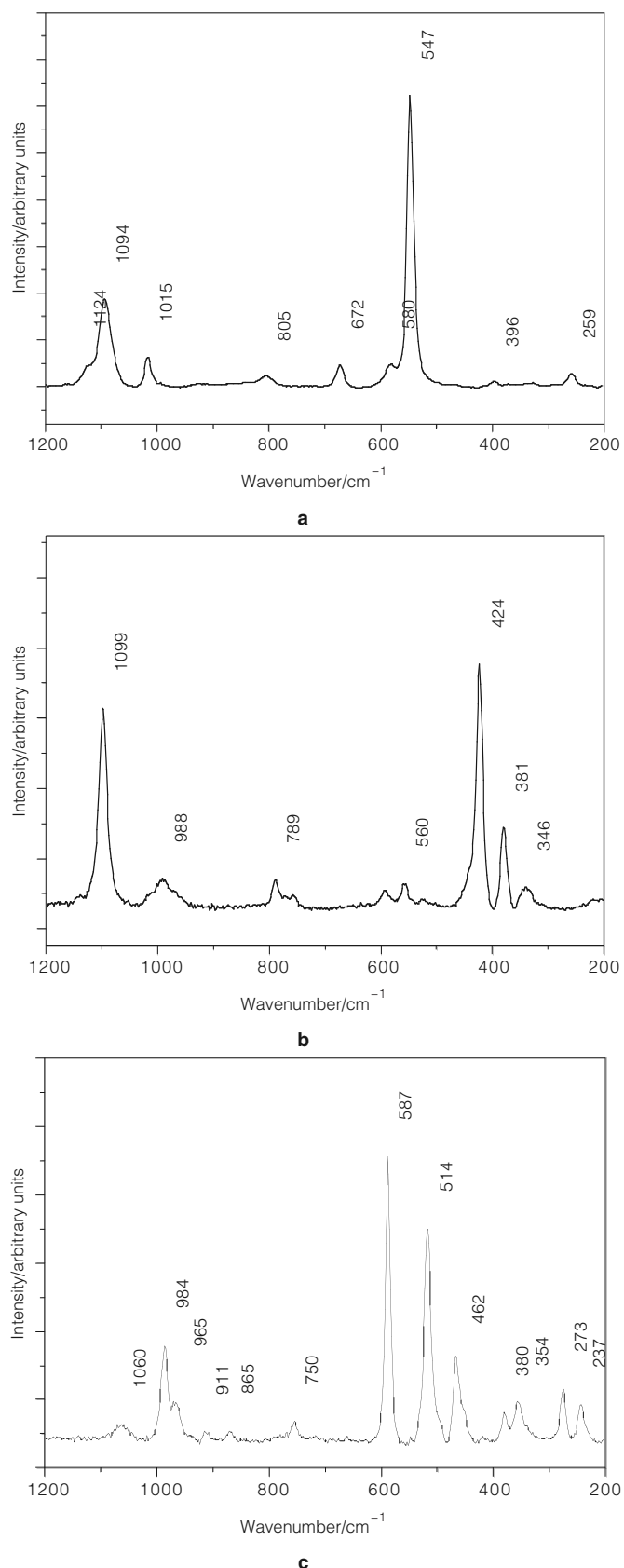

FIGURE 5 Raman spectra of ultramarine blue in bead 1 (a); of Chinese blue in bead 3 (b); and of Chinese purple in the octagonal stick (c) in the range 1200–200 cm^{-1} .

Detailed archeometric investigations of these objects by Raman spectroscopy and scanning electron microscopy (SEM/EDX) revealed that Chinese blue was more frequently present in the earlier objects. In contrast, Chinese purple was the predominant pigment in objects from later periods, not only in the octagonal sticks we studied, but in pigment samples from the Terracotta Army of the Qin dynasty (221–207 B.C.E.) (Thieme 2001; Thieme et al. 1995; Zhou Tie 2001) and in wall paintings in tombs of the Eastern Han dynasty. It should be noted that all the Chinese blue and purple samples always contained considerable amounts of lead. As described earlier, lead additives in these pigments act as catalyst and flux.

Ultramarine Blue

In two of the beads we studied (fig. 4, beads 1 and 2) from the late Western Zhou dynasty and the Spring and Autumn period, Raman spectroscopy detected ultramarine blue particles in the glassy surface in conjunction with either Chinese blue or Chinese purple (fig. 5).

Natural ultramarine blue pigment was originally prepared from lazurite (the primary blue mineral component of lapis lazuli). However, natural ultramarine blue was rarely used in ancient China (Berke and Wiedemann 2000); when it was used, it was applied in much later periods, for example, in the Kizil Grottoes dating from the second and third centuries C.E. (Su Bomin, Li Zuixiong, and Hu Zhide 1999; Su Bomin et al. 2000).

Finding ultramarine blue in these older beads is as yet unprecedented. Although the origin of the pigment—synthetic or mineral—in these objects is still open to question, we suggest that it is a synthetic product, formed serendipitously during the firing process at temperatures ranging from 800 to 1000°C when Chinese purple or Chinese blue was actually being synthesized. A modern synthesis of ultramarine blue uses silica, kaolin, soda or sodium sulfate, sulfur, and charcoal (Seel et al. 1974). At temperatures around 800°C and reducing conditions, sodalite forms and hosts the sulfur molecules, which play the key role in coloring the pigment (see below). These conditions are quite close to the manufacturing process of Chinese blue and Chinese purple, with the charcoal and reducing conditions coming

from the kiln. Only kaolin has to be added, either voluntarily for making a glaze or accidentally as a by-product of the other minerals.

Chemistry. The mineral lazurite—with the empirical formula $\text{Na}_3\text{CaAl}_3\text{Si}_3\text{O}_{12}\text{S}_4$ —from which natural ultramarine blue was prepared—and synthetic ultramarine pigment—with an empirical formula $\text{Na}_{6.9}[\text{Al}_{5.6}\text{Si}_{6.4}\text{O}_{24}]_2\text{S}_2$ (Reinen and Lindner 1999)—both contain sulfur molecules consisting of two or three sulfur atoms trapped in a cage of sodalite. Sodalite is the principal constituent of both lazurite and synthetic ultramarine and has the formula $(\text{Na}_8[\text{Al}_6\text{Si}_6\text{O}_{24}]\text{Cl}_2)_5$.⁵ The typical blue color of both the natural and synthetic pigments comes from blue sulfur radical ions (S_3^-) substituting for sodalite's chloride ions. In synthetic ultramarine, a yellow sulfur ion (S_2^-) often accompanies the blue sulfur ion in varying amounts, resulting in a green (blue plus yellow) variety of this pigment.

In the beads we studied, the radical sulfur anions $\text{S}_2^{\cdot-}$ and $\text{S}_3^{\cdot-}$ were identified simultaneously by Raman spectroscopy (Clark 1995; Clark and Cobbold 1978; Colombari 2003), but the Raman analysis cannot distinguish if the ultramarine pigment is of synthetic or natural origin. However, given the notable absence of pyrite (FeS_2) and the very low content of iron in the ultramarine blue found in the beads, this pigment could not be attributed to the mineral lazurite obtained from lapis lazuli, which has pyrite as a minor component. Rather, it had to be assigned to a synthetic variant.

As mentioned earlier, ultramarine blue particles were found embedded in the glaze of the beads, and this glassy layer would provide all the necessary ingredients for the pigment formation. Other major conditions for the formation of synthetic ultramarine blue are the presence of basic ingredients, such as carbonate (CO_3^{2-}) from plant ash or from witherite (BaCO_3) and sulfur presumably present as sulfate (SO_4^{2-}) from barite, as well as the presence of a reducing agent, here carbon black particles presumably resulting from the operating conditions of a wood-fired kiln.

Thoughts on the Historical Development of the Alkaline-Earth Copper Silicate Pigments

It is still too early to put forth any definitive theory on whether the blue and purple pigments were developed independently of each other or through technology transfer. Some of the evidence for both sides is discussed below.

Evidence for Independent Development

The development of the barium copper silicate pigments—Chinese blue and purple—and serendipitously that of ultramarine blue represents a great ancient Chinese “high-tech” achievement. These blue and purple pigments were used in a relatively confined geographic area of ancient China—the regions of today's Gansu, Shanxi, Shaanxi, and Henan provinces in northwest China, the easternmost part of the Silk Road (Dai Chunyang 2000; Archaeology Institute of Henan Province 1987; Department of Archaeology of Beijing University 1994). To our knowledge, there was no further geographic spread of these Chinese pigments or geographic overlap with the distribution of Egyptian blue. This would suggest that no transmission of the technical know-how for making these very similar pigments took place. However, the picture of the distribution of Egyptian blue in central Asia and that of the Chinese pigments is still incomplete.

Other evidence for the independent origins of the blue and purple pigments comes from the development of vitreous materials (some of the Chinese objects that were investigated for their pigment, including the octagonal sticks, consist partly of vitreous phases). The development of vitreous materials in Egypt and Mesopotamia was widespread and took advantage of the lighter alkaline and alkaline-earth elements, such as calcium, as glassing agents (Tite, Shortland, and Paynter 2002). In contrast, the development of vitreous materials in northwestern China was quite localized. Also, heavy elements such as barium and lead were predominantly used (Brill 1993; Brill, Tong, and Dohrenwend 1991; Brill, Barnes, and Joel 1991; Brill, Tong, and Zhang Fukang 1989). Figure 6 summarizes the hypothesized developments that eventually led to the production of blue and purple pigments in the Western and Eastern worlds.

The chemistry involved in the production of vitreous materials in Mesopotamia or Egypt could have led to the development of Egyptian blue. Likewise, in ancient China, the production of early glassy materials such as glazed stones and faience that used barium and lead could also have led to the development of Chinese blue and purple. These developments of glassy or vitreous materials occurred independently of each other, thus arguing for the independent development of the blue and purple pigments.

Evidence for Technology Transfer

The chemical similarities between Egyptian blue and the Chinese pigments are both striking and intriguing, sug-

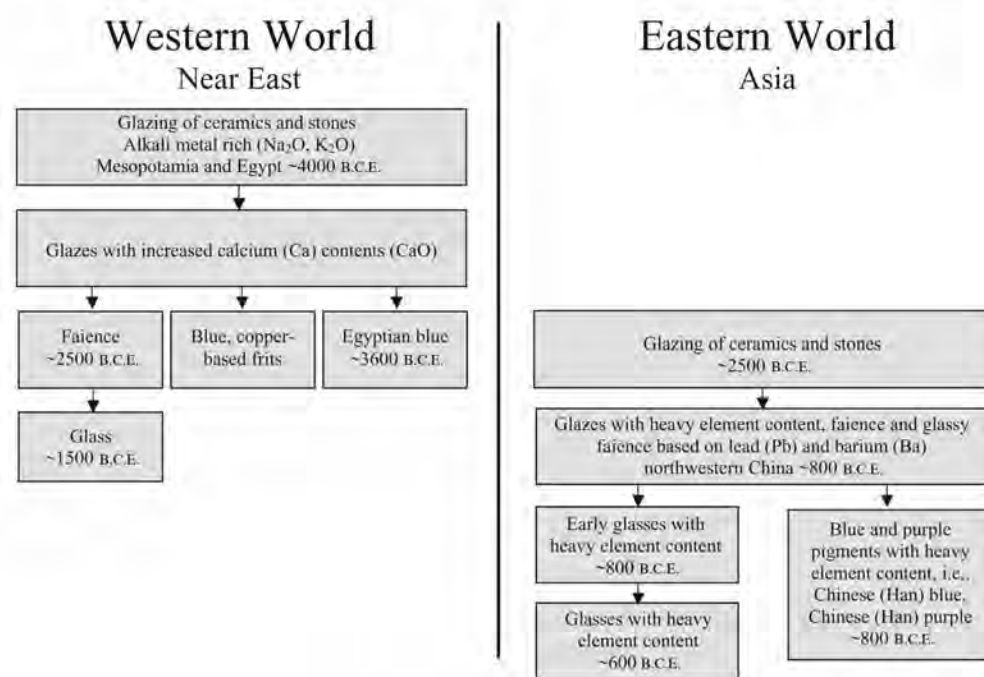

FIGURE 6 Flowchart showing possible pathways for the separate but parallel development of Egyptian blue and Chinese blue and purple in antiquity.

gesting that the Chinese syntheses were based on knowledge of the synthesis of the historically earlier Egyptian blue. Moreover, production of the Chinese pigments is more sophisticated because of the higher temperatures required and the need to carefully control component quantities and the physical conditions of the synthesis. These difficulties, along with the chemical similarities to Egyptian blue, suggest that the Chinese pigments were likely to have been improvements on the Egyptian predecessor rather than independent developments. The question remains as to how knowledge about Egyptian blue spread to China. A technology transfer might have occurred along the Silk Road, but this is a matter to be addressed by future archeometric studies.

Acknowledgments

We would like to thank Neville Agnew and David A. Scott of the Getty Conservation Institute for supporting Ma Qinglin as a visiting scientist during 2001. Thanks also to R. H. Brill of the Corning Museum of Glass for his referral to coauthor Ma Qinglin. We are indebted to the Ägyptisches Museum der Staatlichen Museen Preussischer Kulturbesitz zu Berlin, Germany, for providing a sample of the crown of Nefertiti to H.-G. W.

Notes

- 1 Lapis lazuli is a rock type. The term, however, is often used synonymously for its main mineral component, lazurite (empirical formula $\text{Na}_3\text{CaAl}_3\text{Si}_3\text{O}_{12}\text{S}$ or $(\text{Na,Ca})_8(\text{AlSiO}_4)_6(\text{S}, \text{SO}_4;\text{Cl})_{1-2}$), which is the source of the rock's distinctive blue color. The name ultramarine refers either to the blue pigment obtained from processed lapis lazuli rock or to the synthetically made variety.
- 2 The chemical structure of Egyptian blue possesses a highly robust, infinitely connected, puckered silicate sheet framework that binds to the alkaline earth and the copper ions (Pabst 1959).
- 3 Chinese purple has a unique structure with a copper-copper bond as its crucial structural moiety. Furthermore, although Chinese purple also has a layered structure, its layers are built up from planar isolated $[\text{Si}_4\text{O}_{12}]^{8-}$ rings held together by $[\text{Cu}_2]^{4+}$ units with the Ba^{2+} ions located between layers. The main feature is the Cu_2 unit, which has a Cu-Cu distance of 2.73 Å. It is held together by four bridging SiO_2 moieties from the eight-member silicate rings. Each copper ion is in a square pyramidal geometry.
- 4 Lazurite's somewhat variable calcium content is better shown by the notation $(\text{Na,Ca})_8(\text{AlSiO}_4)_6(\text{S}, \text{SO}_4, \text{Cl})_{1-2}$.
- 5 Sodalite is a defined aluminosilicate containing a framework built from six AlSiO_4 moieties.

References

- Archaeological Institute of Henan Province. 1987. The tombs of Guo State in the village of Shang Cunling, Sanmenxia, Henan. *Hua Xia kao gu = Huaxia kaogu* 3: 104–13.
- Archaeology Team of Baoji City. 1993. Excavation of the tomb no. 2 of the Spring and Autumn period at Yimencun in Baoji City, Shaanxi. *Wen wu* 10: 1–14.
- Archaeology Team of Luoyang City. 1999. Excavation of some Warring States tombs in Luoyang. *Wen wu* 8: 4–13.
- Ball, P. 2001. *Bright Earth: Art and the Invention of Color*. New York: Farrar, Straus & Giroux.
- Bayer, G., and H. G. Wiedemann. 1976. Ägyptisch Blau, ein synthetisches Farbpigment des Altertums, Wissenschaftlich betrachtet. *Sandoz Bulletin: Sonderausgabe* 40: 20–39.
- Berke, H. 2002. Chemistry in ancient times: The development of blue and purple pigments. *Angewandte Chemie—International Edition* 41 (14): 2483–87.
- . 2004. Blau und purpur: Die Erfindung von Farbpigmenten im Altertum. *Restaurio* 110 (6): 401–5.
- Berke, H., and H. G. Wiedemann. 2000. The chemistry and fabrication of the anthropogenic pigments Chinese blue and purple in ancient China. *East Asian Science, Technology, and Medicine* 17: 94–120.
- Bouherour, S., H. Berke, and H. G. Wiedemann. 2001. Ancient man-made copper silicate pigments studied by Raman microscopy. *Chimia* 55 (11): 942–51.
- Brill, R. H. 1993. Glass and glassmaking in ancient China, and some other things from other places. *Glass Art Society Journal: The Toledo Conference*: 56–69.
- Brill, R. H., I. L. Barnes, and E. C. Joel. 1991. Lead isotope studies of early Chinese glasses. In *Scientific Research in Early Chinese Glass: Proceedings of the Archaeometry of Glass Sessions of the 1984 International Symposium on Glass, Beijing, September 7, 1984, with Supplementary Papers*, ed. R. H. Brill and J. H. Martin, 65–83. Corning, NY: Corning Museum of Glass.
- Brill, R. H., Shi Meiguang, E. C. Joel, and R. D. Vocke. 1991. Addendum to chapter 5. In *Scientific Research in Early Chinese Glass: Proceedings of the Archaeometry of Glass Sessions of the 1984 International Symposium on Glass, Beijing, September 7, 1984, with Supplementary Papers*, ed. R. H. Brill and J. H. Martin, 84–89. Corning, NY: Corning Museum of Glass.
- Brill, R. H., S. S. C. Tong, and D. Dohrenwend. 1991. Chemical analyses of some early Chinese glasses. In *Scientific Research in Early Chinese Glass: Proceedings of the Archaeometry of Glass Sessions of the 1984 International Symposium on Glass, Beijing, September 7, 1984, with Supplementary Papers*, ed. R. H. Brill and J. H. Martin, 31–58. Corning, NY: Corning Museum of Glass.
- Brill, R. H., S. S. C. Tong, and Zhang Fukang. 1989. The chemical composition of a faience bead from China. *Journal of Glass Studies* 31: 11–15.
- Chase, W. T. 1971. Egyptian blue as a pigment and ceramic material. In *Science and Archaeology: Papers*, ed. R. H. Brill, 80–90. Cambridge, MA: MIT Press.
- Chiari, G., R. Guistetto, and G. Ricchiardi. 2003. Crystal structure refinements of palygorskite and Maya blue from molecular modelling and powder synchrotron diffraction. *European Journal of Mineralogy* 15 (1): 21–33.
- Clark, R. J. H. 1995. Raman microscopy: Application to the identification of pigments on medieval manuscripts. *Chemical Society Reviews* 24 (3): 187–96.
- Clark, R. J. H., and D. G. Cobbold. 1978. Characterization of sulfur radical anions in solutions of alkali polysulfides in dimethylformamide and hexamethylphosphoramide and in the solid state in ultramarine blue, green, and red. *Inorganic Chemistry* 17 (11): 3169–74.
- Colomban, P. 2003. Lapis lazuli as unexpected blue pigment in Iranian Lājvardina ceramics. *Journal of Raman Spectroscopy* 34 (6): 420–23.
- Dai Chunyang. 2000. Several problems concerning the royal graveyard of the Qin state at Dabuzi, Li-Xian, Gansu. *Wen wu* 5: 74–80.
- Department of Archaeology of Beijing University and Institute of Archaeology of Shanxi Province. 1994. Second excavation of the cemetery of Jin State at Beizhao in Tianma-Qucun Site. *Wen wu* 1: 4–34.
- Fenn, P. M., R. H. Brill, and M. G. Shi. 1991. Addendum to chapter 4. In *Scientific Research in Early Chinese Glass: Proceedings of the Archaeometry of Glass Sessions of the 1984 International Symposium on Glass, Beijing, September 7, 1984, with Supplementary Papers*, ed. R. H. Brill and J. H. Martin, 59–64. Corning, NY: Corning Museum of Glass.
- FitzHugh, E. W., and L. A. Zycherman. 1983. An early man-made blue pigment from China: Barium copper silicate. *Studies in Conservation* 28 (1): 15–23.
- . 1992. A purple barium copper silicate pigment from early China. *Studies in Conservation* 37 (3): 145–54.
- Janczak, J., and R. Kubiak. 1992. Refinement of the structure of barium copper silicate BaCu[Si₄O₁₀] at 300 K. *Acta Crystallographica—Section C* 48: 1299–1301.
- Ma Qinglin, A. Portmann, F. Wild, and H. Berke. 2006. Raman and SEM studies of man-made barium copper silicate pigments in ancient Chinese artifacts. *Studies in Conservation* 51 (2): 81–98.
- Ma Qinglin, Su Bomin, Li Zuixiong, and Hu Zhide. 2001. Ancient Chinese pigments. In *Scientific Research and Conservation of Ancient Chinese Materials*, ed. S. J. Cao, 201–21. Beijing: Science Press.

- Pabst, A. 1959. Structures of some tetragonal sheet silicates. *Acta Crystallographica* 12: 733–39.
- Reinen, D., and G.-G. Lindner. 1999. The nature of the chalcogen colour centres in ultramarine-type solids. *Chemistry Society Reviews* 28 (2): 75–84.
- Riederer, J. 1997. Egyptian blue. In *Artists' Pigments: A Handbook of Their History and Characteristics*, ed. E. W. FitzHugh, 3:23–45. Oxford: Oxford University Press; Washington, DC: National Gallery of Art.
- Seel, F., G. Schäfer, H.-J. Güttler, and G. Simon. 1974. Das geheimnis des lapis lazuli. *Chemie in unserer Zeit* 8 (3): 65–71.
- Su Bomin, Li Zuixiong, and Hu Zhide. 1999. Research on pigments of Kizil Grottoes. In *Conservation of Wall Paintings in Asia: Proceedings of the Ninth Seminar on the Conservation of Asian Cultural Heritage: November 16–19, 1999, Tokyo, Japan*, 59–67. Tokyo: National Research Institute for Cultural Properties.
- Su Bomin, Li Zuixiong, Ma Zengang, Li Shi, and Ma Qinglin. 2000. Research on pigments of Kizil Grottoes. *Dunhuang Research* 63 (1): 65–75.
- Thieme, C. 2001. Paint layers and pigments on the Terracotta Army: A comparison with other cultures of antiquity. In *The Polychromy of Antique Sculptures and the Terracotta Army of the First Chinese Emperor: Studies on Materials, Painting Techniques, and Conservation, International Conference in Xi'an, Shaanxi History Museum, March 22–28, 1999 = [Gu dai diao su cai hui Qiushihuang bing ma yong: Cai liao, hui hua ji shu he bao hu zhi yan jiu]*, ed. Wu Yongqi, Zhang Tingbao, M. Petzet, E. Emmerling, and C. Blänsdorf, 52–58. Arbeitsheft (Bayerisches Landesamt für Denkmalpflege), vol. 111. Munich: Bayerisches Landesamt für Denkmalpflege.
- Thieme, C., E. Emmerling, C. Herm, Yon Qi Wu, Zhou Tie, and Zhang Zhijun. 1995. Research on paint materials, paint techniques, and conservation experiments on the polychrome Terracotta Army of the first emperor Qin Shi Huang. In *The Ceramics Cultural Heritage: Proceedings of the International Symposium, The Ceramics Heritage, of the 8th CIMTEC—World Ceramics Congress and Forum on New Materials, Florence, Italy, June 28–July 2, 1994*, ed. P. Vincenzini, 591–601. Monographs in Materials and Society, no. 2. Faenza: Techna.
- Tite, M., A. Shortland, and S. Paynter. 2002. The beginnings of vitreous materials in the Near East and Egypt. *Accounts of Chemical Research* 35 (8): 585–93.
- Wiedemann, H. G., and G. Bayer. 1997. Formation and stability of Chinese barium copper silicate pigments. In *Conservation of Ancient Sites on the Silk Road: Proceedings of an International Conference on the Conservation of Grotto Sites*, ed. N. Agnew, 379–87. Los Angeles: Getty Conservation Institute.
- Wiedemann, H. G., G. Bayer, and A. Reller. 1997. Egyptian blue and Chinese blue: Production technologies and applications of two historically important blue pigments. In *La couleur dans la peinture et l'émaillage de l'Égypte ancienne: Actes de la Table ronde, Ravello, 20–22 mars 1997*, ed. S. Colinart and M. Menu, 195–203. Scienze e materiali del patrimonio culturale, no. 4. Bari: Edipuglia.
- Wiedemann, H. G., and H. Berke. 2001. Chemical and physical investigations of Egyptian blue and Chinese blue and purple. In *The Polychromy of Antique Sculptures and the Terracotta Army of the First Chinese Emperor: Studies on Materials, Painting Techniques, and Conservation, International Conference in Xi'an, Shaanxi History Museum, March 22–28, 1999 = [Gu dai diao su cai hui Qiushihuang bing ma yong: Cai liao, hui hua ji shu he bao hu zhi yan jiu]*, ed. Wu Yongqi, Zhang Tingbao, M. Petzet, E. Emmerling, and C. Blänsdorf, 154–70. Arbeitsheft (Bayerisches Landesamt für Denkmalpflege), vol. 111. Munich: Bayerisches Landesamt für Denkmalpflege.
- Zhou Tie. 2001. New developments in the conservation of the polychromy of the Terracotta Army. In *The Polychromy of Antique Sculptures and the Terracotta Army of the First Chinese Emperor: Studies on Materials, Painting Techniques, and Conservation, International Conference in Xi'an, Shaanxi History Museum, March 22–28, 1999 = [Gu dai diao su cai hui Qiushihuang bing ma yong: Cai liao, hui hua ji shu he bao hu zhi yan jiu]*, ed. Wu Yongqi, Zhang Tingbao, M. Petzet, E. Emmerling, and C. Blänsdorf, 23–30. Arbeitsheft (Bayerisches Landesamt für Denkmalpflege), vol. 111. Munich: Bayerisches Landesamt für Denkmalpflege.
- Zibo Museum. 1997. Excavation of the Warring States tomb at Shangwangcun, Linzi, Shandong. *Wen wu* 6: 14–26.

Ishkor Glazes of Uzbekistan

Pamela B. Vandiver, Amy Vandiver, Akbar Rakhimov, and Alisher Rakhimov

Abstract: Reverse engineering of early craft technologies involves using the basics of materials science and engineering to a new end—their preservation and continuity. This paper presents a case study of the analysis and reconstruction of the traditional glazed pottery and tile technologies of Samarkand, Bukhara, Khiva, and other Silk Route cities of Uzbekistan that date to the twelfth century C.E. and possibly earlier. A comparison is made of these analyses to the analysis of wares of modern artisans who have kept alive traditional craft practices that they can document to the sixteenth century. Tiles made by the traditional *ishkor*, or plant ash, process are more durable and have a brilliant, translucent appearance similar to that of the architectural tiles on ancient monuments along the Silk Road and are once again being used in restoration. Further analysis has shown why the modern tiles typically used in restoration are not durable and do not have the correct appearance.

From the thirteenth to the nineteenth century C.E., public architecture in Samarkand, Bukhara, Khiva, and other World Heritage Sites along the Silk Road in Uzbekistan was decorated with brilliant, glossy, translucent glazed tiles that display great variation in visual effect and underlying technology. The characteristic glaze, known as *ishkor* in Uzbek, is produced from the ash of desert plants. Conservation practice for these structures prior to this study was that modern tiles were manufactured in industrial factories in Uzbekistan with commercial materials first from Russia and later from Italy and Vietnam to replace ancient ones that had deteriorated or been lost. However, most of the modern tiles deteriorate faster than the old ones they replace, or they are fired to such a high temperature that they match neither the color

nor the gloss of either the original tiles or older replacement tiles. To solve the problem of producing glazed tiles with a similar visual appearance, we studied traditional tile- and pottery-making workshops in Uzbekistan, many of which trace their master potter lineage to the seventeenth century. In this study, master potters were interviewed,¹ their working methods studied, and both raw materials and finished products sampled for analysis. Results of analyses of the traditionally made wares were compared with those of ancient tiles, and the traditionally made tiles were evaluated for durability.

Many of the modern but traditional Uzbek ceramic practices match the technologies used for the ancient tiles. However, these practices are no longer economically viable and should be considered as intangible cultural heritage. The International Council of Museums in October 2004 accepted a new UNESCO charter for the preservation of intangible cultural property, defined as performance-based arts and technologies (UNESCO and Korean National Committee 2003). Examples are cultural masterpieces of music, dance, puppetry, theater, festivals, and traditional craft knowledge and practice. This charter is similar to the Burra Charter of Australia ICOMOS (2000) and the Convention for World Cultural and Natural Heritage Protection (UNESCO 1972), which serve as the legal framework to preserve World Heritage Sites. Both charters have three major selection criteria for cultural property: cultural significance, authenticity, and integrity. Continuity is not one of these criteria. Thus craft knowledge, lost through disuse, death, or cultural calamity, can be reverse engineered, revived, and transmitted as intangible cultural heritage. Analysis and reconstruction of ancient technologies usually involves an iterative process

of contextual investigation, resource survey, analytical characterization, replication and use of standards, and, finally, reanalysis of the mechanisms of material transformations and their application to modern materials. The critical factor that is being recognized is the knowledge of the practitioner, or, as stated in the charter, the “outstanding value as a masterpiece of . . . human creativity” (UNESCO 1972: 30).

Many European and Asian countries have revived ancient and historic ceramic styles of cultural significance, and the products are sold as replicas, although they are not labeled as such. Ceramics are sold with an artist’s signature only if value is enhanced, and in Asia this involves acceptance of Euro-American art standards. The Asian view, predominant in China for the past thousand years as well as in contemporary Uzbekistan, is that replicas are not fakes and forgeries but a complement to a past tradition that is being revived, continued, and collected as an heir to that tradition. The onus and challenge reside in the scholarship of the collector or collection agency to determine date or period of production. Only when a modern replica is described or sold as ancient is there intent to deceive, and only then does the object become a fake or forgery. The Asian view is that such replicas satisfy the market, keep a tradition and its attendant craft knowledge alive through practice, and remove at least some of the temptation to loot sites and ignore antiquities laws by carrying on illicit trade.

Uzbekistan is most fortunate to have more than twenty-five families practicing ceramics in traditional workshops, but each workshop master keeps its special practices secret. In 1930 more than one hundred pottery and tile workshops were documented (Rakhimov 1961). Today the traditional workshops produce only pottery, although tiles are produced in the traditional manner for use on private family tombs. UNESCO is helping to support a pottery school in Tashkent with the aim of transferring the old ceramic technology to future generations. That school was organized and is run by the last two authors of this study (Khakimov 1999). Our role as materials analysts is to reconstruct the missing steps and variability in the technology that the masters are unwilling to describe and to evaluate the durability of the ceramics and their suitability for monument conservation. This paper presents a case study of traditional glazed-tile technologies that date from the thirteenth to nineteenth centuries C.E. and that are still being practiced in Samarkand, Bukhara, Khiva, and other Silk Road cities of Uzbekistan, although they are no longer known and practiced in western China, Mongolia, or Turkmenistan.

Variation in Appearance of Traditional *Ishkor* Glazed Architectural Styles Used on Public Monuments

In addition to a distinguished tradition of pottery (Golombek, Mason, and Baily 1996), Uzbekistan is heir to an astounding and varied glazed-tile and glazed-brick architectural tradition (Michaud, Michaud, and Barry 1995). The characteristic glaze, or *ishkor*, is produced from the ash of desert plants. Most early monuments were made of earthen adobe walls, but starting in the twelfth and thirteenth centuries building walls were constructed of fired bricks made from local loess that fired at 1,100°C or below to yield a yellow color. The fired brick produces a much more durable monument even if only the surface is clad in fired tile (Amery and Curran 2001: cf. fired brick styles, 103–5, 109–12; and cover to preservation of unfired brick structures, 78, 129). Several special *ishkor* glazed architectural styles have developed.

Inset Ceramic Panel in Brick or Tile

The oldest Islamic style, dating to the twelfth and thirteenth centuries in Bukhara, is characterized by the stacking of bricks into deeply textured relief patterns; in some cases as many as twenty-five different stacking patterns occur in the same building. Some pattern blocks had bricks placed in mostly diagonal patterns, similar to woven reed patterns, with holes through the walls that allowed air to circulate inside the building for cooling. Inscriptions and relief friezes were glazed with a soft, almost opaque turquoise blue *ishkor* glaze that contrasts beautifully with the yellow brick; these glazed pieces were placed into only a few important places on the exteriors of buildings. This textured brick architectural style survives today in Khiva in the more highly fired (approx. 1200–1250°C) stacked patterns in reddish brick with dark brown trim bricks.

Single-Color Distributed Glazed Brick

The most common and widespread Uzbek monument style is rectilinear and dates from the thirteenth century; it continues to the present. It is characterized by uniform-sized yellow bricks stacked on edge in a variety of patterns and interspersed with same-sized bricks glazed on a single, exterior side with copper turquoise blue most commonly but also cobalt blue and, rarely, yellow and white. One example is the exterior of the Bibi Khanom mosque (1399 C.E.) in Samarkand (Michaud, Michaud, and Barry 1995: 82–83). This

architectural style and the one described above can be read and recognized at a considerable distance.

Mosaic Tile Panels and Surfaces

Uzbek architecture has a variety of other ways to employ *ishkor* glazes, primarily on tiles that are inset into walls or domes or applied to columns. Imported from the south, Afghanistan and Iran, are Persian-style mosaic-style tiles from the fourteenth and fifteenth centuries. The visual effect is much like curvilinear patterns in Persian carpets. Single-color glazed tiles are fired, and then, with a labor-intensive process akin to stone-working, different pattern pieces are cut and ground and closely fit together into a complex, multicolored, flat mosaic design. Many inset mosaic panels are found at the Shakhizinda burial complex, the Registan World Heritage Site, and the Bibi Khanom mosque, all in close proximity in Samarkand (see, e.g., Michaud, Michaud, and Barry 1995: 88, 89, 92, 93). In Turkey and Iran this mosaic style is practiced on a relatively small scale, with mosaic tile panels inset into niches, but in Uzbekistan this style is practiced on a monumental scale.

Deep Hand-Cut Incised Tiles

This style involves producing repeat curvilinear patterns in deep relief (Michaud, Michaud, and Barry 1995: 108–9, 113). A complex pattern is overlaid from a stamp or stencil; then a pattern is cut into the soft clay tile, followed by glazing. The pattern appears as in relief.

Molded Relief Tiles

An unfired, quite plastic clay body is pressed with or into an open-face mold that contains a design in deep relief (Michaud, Michaud, and Barry 1995: 114, 119). After the tile is removed from the mold, the relief is refined by hand tooling. This style is commonly found on single-colored tiles on the exterior of buildings, for example, at the Shakhizinda. The difference between this and the previous style is difficult to detect and requires examination of the tool marks in the indented pattern.

Applied Quartz-Slip Relief Tile

A quartz-based slip is applied to a flat tile to produce a gentle raised relief pattern that is only a few millimeters thick (Michaud, Michaud, and Barry 1995: 118–19). When the tile is painted and glazed with the background in a deep blue reserve, the light is reflected from the white, somewhat rounded and raised sculpted floral patterns. As one approaches a building with these tiles, it appears to shimmer in sunlight.

Interior Cobalt Blue, Gold-Foil Dome Tiles

Cobalt blue glazed tiles on the interiors of domes are decorated with gold-foil stars and other geometric shapes that are attached by applying and firing an opaque red, iron oxide-containing overglaze enamel onto the glazed tile where the foil is attached and beyond the edge of the foil, as seen, for example, at the Shakhizinda burial complex in Samarkand. While the enamel is still wet, the gold foil or gold leaf pieces are applied. The tile is then refired at a lower temperature than that used for the original glaze firing, such that the enamel partially melts to adhere the foil. Gazing upward into one of these domes is like viewing a dome of the night sky, a motif common to both Chinese and Egyptian tombs, but in the Islamic architecture of central Asia the reflection from the glassy and metallic surfaces produces an optical effect in which the stars flicker and the sky shimmers with light.

Each of these very different and wonderful visual effects is produced by a general *ishkor* glaze technology that is applied in a special way with certain difficult steps. The visual effect of these different glazed bricks and tiles changes depending on the light source—candles, oil lamps, or sunlight—and on the time of day and the extent of shadow and reflection.

Preserving Ancient Tiled Monuments

The use of commercial replacement tiles on ancient tiled monuments in Uzbekistan is creating preservation problems. These commercial tiles often have been fired at too low a temperature, resulting in porous tiles that are attacked by high groundwater levels, high humidity, and rain. Through capillary action, groundwater climbs through the walls of monuments to levels of 8 to 10 meters, leaving salts and discoloration, delaminating tiles, and partially eroding the walls, particularly at brick joints. Some industrial plants making commercial tiles also fire them quite high, to 1,200°C or more. Above this temperature the yellow-firing clay tends to turn reddish and darken, such that the color of the commercial tiles does not match that of the ancient tiles they are replacing. In addition, some firms state that they use glazes and colorants from Italy and Vietnam because of their low cost. The same industry that makes tile for interior floors and walls also makes replacement tiles for the exteriors and interiors of ancient monuments. The commercial glazed tiles that were being used at the Bibi Khanom mosque in Samarkand appeared quite opaque and lacked the brilliance and gloss of even the tiles that were used to replace originals during an early-twentieth-century restoration. The new tiles also dete-

Table 1 Chemical Composition of Glaze from Modern vs. Sixteenth-Century Tiles from Bibi Khanom Mosque, Samarkand, Uzbekistan

Modern (2001) Restoration Tiles: Tile body made of 80 wt% Khojigadish calcareous loess and 20% Angren clay															
Glaze	Composition														
	SiO ₂	Al ₂ O ₃	Fe ₂ O ₃	CaO	MgO	K ₂ O	Na ₂ O	P ₂ O ₅	PbO	TiO ₂	CuO	CoO	MnO		
White, clear	43.31	3.59	1.02	2.03	1.04	1.27	8.34	0.24	32.02	0.12	0.79	0.08	0.04		
Blue, CuO	42.43	3.34	1.15	2.46	1.18	1.3	5.27	0.18	33.88	0.02	1.18	0.06	0.02		
Blue, CoO	38.01	1.9	0.57	1.38	0.38	0.75	2.33	0.04	47.85	0.43	0.03	0.58	0.04		
Blue, CuO	42.9	2.59	0.82	1.8	1.52	1.94	3.55	0.16	40.16	0.02	0.76	0.25	0.03		
Sixteenth-Century Tile: Tile body probably made of Khojigadish calcareous loess and quartz sand with 0.03 wt% Fe ₂ O ₃ impurity*															
Glaze	Composition														
	SiO ₂	Al ₂ O ₃	Fe ₂ O ₃	CaO	MgO	K ₂ O	Na ₂ O	P ₂ O ₅	PbO	TiO ₂	CuO	CoO	MnO	SO ₃	Cl
Blue, CuO	49.78	4.23	0.91	2.18	1.09	2.08	7.05	0.15	24.99	0.1	1.29	0.05	0.01		
Blue, CoO	40.38	1.2	0.46	1.14	0.64	0.83	3.81	0.09	42.94	0.01	0.04	0.63	0.01		
Green, CuO	33.22	3.52	0.29	0.57	0.11	0.54	0.12	0.02	52.47	0.1	2.3	0.04	0.01		
Body	Composition														
Blue, CuO	62.89	24.46	3.37	2.45	0.8	3.02	1.25	0.27	0	0.94	0.17	0.14	0	0.22	0.02
Blue, CoO	62.08	22.5	4.12	1.26	1.25	3.4	0.78	0.28	0	0.95	0	0	0	0.44	0.14
Green, FeO	63.95	22.17	2.68	3.85	0.97	4.2	0.61	0	0.73	0.91	0	0	0	Present	Present

*These samples were collected by Mukhitdin Rakhimov, who believed they came from one workshop as they were placed in a mosaic panel alongside one another.

Analysis of polished, carbon-coated sample cross sections by electron probe microanalysis (EPMA, or microprobe analysis) using a wavelength-dispersive Cameca V, run at 15 V accelerating voltage, 10 seconds or 10,000 count, beam defocused to 10 microns and calibrated with geologic standards. Major elements are accurate to 3 to 5%; minor elements, to 10%. Each analysis is the average of 5 to 9 points.

riorated rapidly, displaying surface cracks that localize salts, especially at the end of drying, and that lead to delamination of the glaze from the body.

We analyzed glaze samples from modern tiles used during restoration of the Bibi Khanom mosque in 2001 and compared them with old tiles placed in the sixteenth century. The results showed that the chemical compositions of the old and new glazes do not differ significantly (table 1). However, the microstructures of the two glazes were very different (figs. 1, 2), and this explains the differences in visual appearance and durability. The color in the modern restoration tiles was concentrated in the upper 10 percent of the thickness of the glaze, leading to a loss of the desired depth and brilliance. This is the result of a manufacturing practice that reduces the amount of colorant used to make the glaze; this reduces costs but produces tiles with a flat, dull appearance.

In addition, quartz particles had been dusted onto the unfired, still-wet glaze surface of floor tiles at the Bibi Khanom mosque, a modern practice common for floor tiles to produce better wear resistance. As the glazed-tile floor wears during use, the quartz particles round a bit but remain in relief at or near their original level and protect the floor from further abrasion. However, these quartz particles have a different rate of contraction than does the glaze, and on cooling in the kiln, cracks form around them. These cracks

are the weak link that serves to initiate corrosion, as the cracks will grow slowly with changes in temperature, relative humidity, and vibration. When moisture evaporates, salts will concentrate in these rough cracked areas. In summary, the modern ceramic technology produces tiles that are deleterious to monument preservation.

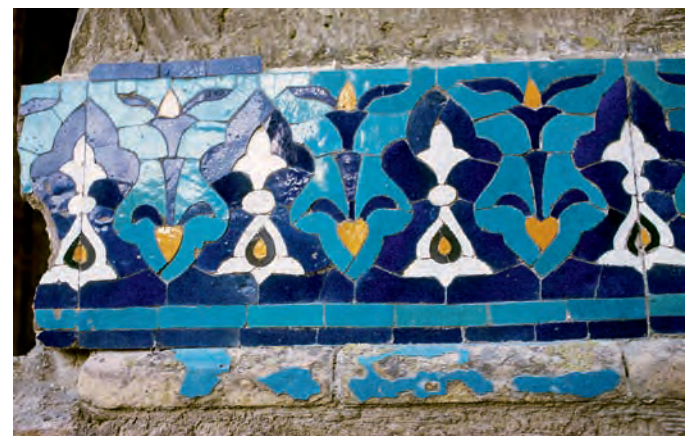

FIGURE 1 Tiles in yellow, white, a lapis lazuli or cobalt blue, and a turquoise or copper green from the Bibi Khanom mosque, sixteenth century. Tiles were glazed as large square tiles and then cut and ground to fit a flower-patterned frieze, using a Persian mosaic style of tile decoration.



FIGURE 2 Modern tiles in a similar pattern and, to the left, the samples we analyzed in table 1.

Composition of Old and New Glazes

As table 1 shows, the traditional glazes have a wider range of composition than the glazes used on modern restoration tiles. The glazes were analyzed by electron probe micro-analysis (EPMA), as described in table 1. However, both glazes are of a similar type, lead-alkali-silicates, but both are complex, each having several sources of alkali, alkaline earth, and other constituents. Having a range of these constituents is advantageous for melting the glaze during firing and for durability, but it is difficult to assess the sources of the raw materials. For instance, soda and potassa together are a stronger flux than either alone—known as the mixed-alkali effect, producing melting at a lower temperature than does the single alkali. For instance, the alkaline earths, MgO and CaO, that produce stability are in a ratio of about 1:2 and are similar to the ratio in a dolomite source rock. The process of understanding the technology involves thinking about the role of the different constituents, but in this case complex glaze compositions clearly were preferred; we cannot specify whether they were compounded from many raw materials or from a single complex material without additional information. The practice of modern pottery and

tile workshops producing traditional pottery glazes involves the use of special plant ashes, and potters can document this practice for several hundred years as a conservative technological style or special, repeated way of making a culturally significant object. Akbar Rakhimov once characterized this special technology as the making of “natural vegetable glazes with organics.”

Ishkor or Desert Plant Ash Glazes

To produce the varied visual effects seen in traditional glazed tiles made over a seven-hundred-year period involves a well-developed technology that could be practiced over a large geographic area with relatively little risk of failure. A readily available, single source of raw materials for the glaze was and still is available to potters in the form of plant ash, or *ishkor* in Uzbek, made from many desert plants. In the family Chenopodiaceae, special salt-concentrating *Salicornia* and *Salsola* desert plants, better known as tumbleweeds, saltwort, or Russian thistle, of which seventy-two are known in Uzbekistan (Komarov and Shishkin 1970), are harvested at the end of the summer, dried, and slowly burned in a reducing or smoky atmosphere at perhaps 500°C to 700°C to produce the ash. These plants include *Salsola soda*, *S. kali*, *S. foetida*, *Haloxyton recurvum*, *H. multiflorum*, and *Salicornia*, and we have found many of them from Khiva to Tashkent, as well as in the Ferghana Valley. Near Khiva, an especially revered grove of these plants was near tree height, about 20 feet tall, and could only be appreciated as a special vegetable by a hungry camel or a knowledgeable potter. The lumps and cakes of ash produced from these plants vary in appearance from black stonelike or slaglike with conchoidal fracture to a dense, gray ash with black carbonized plant debris and residual stems and plant bits.² To make an *ishkor* glaze out of the plant ash involves fritting and grinding the ash, sometimes repeatedly, and adding other constituents, such as quartz, colorants, and sometimes lead oxide as a flux and brightener and tin oxide as an opacifier and whitener. The use of plant ash in glass and glazes is widespread in the desert regions of a large part of central and southwestern Asia and the Mediterranean basin, and the formulations are quite consistent.³ Ethnographic interviews with potters as well as textual evidence repeatedly suggest that to one part powdered quartz is added one to one and a half parts dried and ashed desert plants, that is, 50 to 60 wt% SiO₂. When Rye and Evans (1976) observed ashing, they noted that the best-quality alkali material formed a liquid below the burn-

ing plants, fused at a relatively low temperature, and could be used in the glaze or glass frit at a 1:1 ratio by weight with quartz. The author Abu'l-Qasim, writing in about 1200, also stated the latter was a high-quality material (Allan 1973); however, Rye and Evans found that Multan potters preferred the lower-quality ash that had to be mixed with quartz at a ratio of 1.5:1 by weight. Thus potters and others who use the ashed plant materials discern variability in composition that they relate to variation in properties that develop during the ashing step, not the variations in soil composition and various environmental factors that affect how the plant acts as a filter for constituents in the soil.

Figures 3–5 show the five plants that Uzbek potters most frequently use for their *ishkor* glazes, with the ash from each plant contributing different properties to the glaze. Based on microscopy of prepared cross sections, Harry Alden, botanist with the Smithsonian Institution, identified them as varieties of *Salsola kali* and *S. soda*. Scientists at the University of Arizona Herbarium stated that these particular Uzbek plants are not common in the American southwestern deserts, unlike many species that were spread with wheat seed by Russian colonists to the American and Canadian West. These plants are the following:

- *Gulaki*: Two red and yellow flowering varieties of *gulaki*, a local Uzbek name meaning “flowering,” provide a low-melting-temperature ash that is used primarily for glazes on pottery vessels, especially serving bowls and plates that are sold in the marketplace to serve and prepare, but not store, food. These vessels have the highest fluxed glaze and are the least stable, and some potters said that they use this ash with the expectation that clients will replace the pottery yearly, an example of planned obsolescence, or that the pottery primarily serves a decorative function in modern homes and offices.
- *Qirqburun*: Two red and yellow flowering varieties of *qirqburun*, meaning “forty joints or knuckles,” are lower in highly fluxing constituents, thus producing glazes that are more durable. They are used on tiles for family graves and on special vessels for display, for storage, and for food preparation. These are ceramics that are meant to last.
- *Balaq kuz*: *Balaq kuz*, meaning “fish-eyes” because of its large round seeds, is found primarily in the south near Termez and Boiysun, an area designated by UNESCO as an intangible cultural and natural



FIGURE 3 *Gulaki* plant in red and yellow flowering varieties and somewhat fused ash cake (upper right).



FIGURE 4 *Qirqburun* plant in red and yellow flowering varieties and poorly fused ash cake (upper right).



FIGURE 5 *Balaq kuz* plant and ash cake with an intermediate amount of glass (upper right).

site, but even there it is not as common as the other plants. This plant can also be found in the Ferghana Valley and near Tashkent, but its occurrence is not sufficiently abundant for use in *ishkor* glazes. The composition is intermediate between those of *gulaki* and *qirqburun*.

Uzbek potters are aware of the ecological problems created by overusing the plants, and many state that they are trying to maintain a delicate balance between using the plants in a way that will not cause their demise and keeping alive a traditional, but very labor-intensive, technology that produces glazes with a beautiful, brilliant appearance. Because of the yearly variability of these plants and the considerable effort required to make the plant ash, many young potters are changing to glaze compositions that are high in lead oxide or that are commercially available. Examples of this are given in note 1.

Analysis of Plants and Ash Used for *Ishkor* Glazes

In general, plants act as filters for elements that are present in the immediate soil environment, and desert plants in particular gather high concentrations of soluble salts and other minerals. Table 2 presents compositions of three common types of plant materials used in the production of *ishkor* glazes. The top group assesses variability in raw, unfired plant parts; the second, ash that is ready for use in a glaze. These analyses were conducted with a scanning electron microscope with simultaneous energy dispersive X-ray analysis (JEOL840-II with Thermo Electron System 6 EDS) using a 20 kV accelerating voltage, 150 to 180 seconds counting time. For concentrations above 10 percent, the numbers are accurate to about 5 percent; for concentrations below 10 percent, accuracy decreases to 10 percent. The analyses were standardized with the working standards of Corning glasses A through D. As shown in figures 3–5 and the upper part of table 1, the compositions of the various unfired or raw plant parts demonstrate lots of variability according to the function served. Analyses of the *gulaki* plants we ashed in August 2000 show a more potassia- and soda-rich ash composition, whereas the *qirqburun* contains more alumina, calcia, iron oxide, and phosphorus pentoxide, yielding a higher melting glass. These compositions are highly variable, but much of the sulfate and chloride in the raw plant parts has burned off. The plants were collected with the ceramic

master, Gofferjahn Marajapov, in a 100-meter area near Gurumsaray in the northern Ferghana Valley and partially dried and burned at about 700°C in late August, though September is the preferred time as it is dryer and the plants contain less water. The Ferghana Valley is a high mountain valley in the east of Uzbekistan that is the source of the Syr Darya River and has served throughout history as an over-summer reserve for caravans wanting to avoid the hot, dry lower deserts and needing to find fodder for their animals.

Reconstructing the Secrets of the Process of *Ishkor* Glaze Production

Here the traditional process for producing and applying *ishkor* glazes is described in more detail. Figures 6–8 show most of the sequence of steps, or chain of operations.

Plant Collection and Ashing

We collected plants from a drainage swale near the town of Namangan in the Ferghana Valley with Gofferjahn Marajapov, a local pottery master. The surface of the soil was not covered with a layer of salt, nor was the soil salty tasting, having a pH of about 7.9, or only slightly alkaline. The plants are usually dried on the ground for about two weeks in the 40°C heat, then ashed in a slow, smoky fire to about 700°C; however, our plants were dried for only a day and then fired in near-windless conditions (fig. 6). The surface of the stack



FIGURE 6 Gofferjahn Marajapov and Akbar Rakhimov ashing a smaller than usual stack of *ishkor* plants in the Ferghana Valley, early September 2001. This firing was primarily a demonstration.

Table 2 Compositions of Plant Parts and Ash from Different Plants Used in *Ishkor* Glazes

	SiO ₂	Al ₂ O ₃	Fe ₂ O ₃	CaO	MgO	K ₂ O	Na ₂ O	P ₂ O ₅	SO ₃	Cl	CuO	TiO ₂	Total
Ishkor Plants Collected near Gurumsaray, Ferghana Valley													
Petal, <i>gulaki</i> , red flower	11.63	13.55	0.94	4.26	21.35	6.1	28.11	1.21	8.97	3.87	0	0	100
Seed, <i>gulaki</i> , red flower	15.36	5.12	8.09	11.48	8.79	12.23	15.4	2.22	17.85	3.09	0.6	0	100
Seed, <i>gulaki</i> , yellow flower	8.74	5.24	0	3.07	15.65	13.37	27.17	2.14	10.77	10.49	0	0	100
Stem exterior, <i>qirqburun</i> , red	34.28	16.17	5.19	8.01	16.35	2.2	10.4	0	5.15	2.26	0	0	100
Stem interior, <i>qirqburun</i> , red	2.06	0.43	0.46	7.49	1.94	26.51	19.18	4.11	15.38	20.89	1.56	0	100
Stem interior, <i>qirqburun</i> , yellow	4.58	0.98	0	5.39	9.08	2.24	50.43	1.45	19.87	5.15	0	0	100
Seed exterior, <i>qirqburun</i> , yellow	35.94	17.37	5.28	7.68	8.18	2.77	13.2	0	6.03	2.77	0.76	0	100
Seed interior, <i>qirqburun</i> , yellow	14.9	5.95	1.52	8.75	4.14	19.43	16.53	3.47	5.94	19.36	0	0	100
Petal, <i>balak kuz</i> , red flower	22.02	10.29	1.86	3.95	4.17	15.77	14.39	0.94	7.34	13.63	5.65	0	100
Seed interior, <i>balak kuz</i>	32.04	11.22	8.74	12.28	4.11	5.91	9.03	0	8.74	11.43	0.7	0	100
Seed exterior, <i>balak kuz</i>	31.72	13.11	4.11	4.19	6.33	4.9	15.29	4.63	7.82	6.36	1.55	0	100
Stem exterior, <i>balak kuz</i>	26.63	13.98	4.17	17.09	10.32	9.16	10.27	0.06	5.73	2.39	0.19	0	100
Stem interior, <i>balak kuz</i>	23.31	14.57	3.38	5.99	12.78	4.58	15.78	0	8.16	10.4	1.03	0	100
Ishkor Plant Ash Cake Made by Authors, Ferghana Valley													
<i>Gulaki</i> ash cake	34.24	2.9	0.36	6.8	2.7	6.35	35.62	0.04	0	0	0	0	100
<i>Qirqburun</i> ash cake	26.74	8.79	0	27.04	1.79	1.08	26.54	3.67	0	0	0.59	0	100
Prepared Plant Ash Samples Collected from Potters in the Ferghana Valley													
Milled, mixed plant ash, Gofferjahn Marajapov, Gurumsaray, #1	58.45	6.34	1.38	9.06	4.76	7.34	12.13	0.32	0	0	0	0.21	100
Milled, mixed plant ash, Gofferjahn Marajapov #2	54.7	6.16	1.57	7.36	4.58	7.76	17.2	0.52	0	0	0	0.24	100
Mixed plant ash, Hakkim Satimov, Gurumsaray	53.31	6.27	1.67	7.59	4.68	6.36	18.7	0.51	0	0	0	0.91	100
Mixed plant ash, Masadullo Turapov, Rishton	55.6	6.52	1.84	8.41	4.57	7.56	14.57	0.5	0	0	0	0.27	100
Mixed plant ash, Ibrihim Kamillov, Rishton	60.03	6.59	0.75	2.45	0.25	4.06	26.02	0.06	0	0	0	0.02	100
Prepared <i>Ishkor</i> Plant Ash Variation, Ferghana Valley													
<i>Ishkor</i> mixed plant ash	63.5	7.62	1.81	5.56	2.91	4.77	13.13	0.37	0	0	0	0.35	100
<i>n</i> = 88 with standard deviations of	3.5	0.9	0.5	0.9	0.3	0.6	1.9	0.2				0.2	
<i>Ishkor</i> mixed plant ash	56.42	6.38	1.44	6.97	3.77	6.62	17.73	0.38	0	0	0	0.33	100
<i>n</i> = 57 with standard deviations of	4.6	0.8	0.4	1	0.4	0.8	2.4	0.2				0.2	

Number of analyses (*n*) was 1, unless otherwise noted. A JEOL 840-II SEM-EDS was used with operating parameters of 20 V, 15 mA. The largest possible single-phase-assemblage areas were analyzed for 2 minutes. Semiquantitative ZAF corrections were applied with totals normalized to 100. Corning Glass standards A to D were analyzed successfully as working standards both before and after those given above. Carbon and oxygen, though the major components of these samples, were not analyzed. Fresh fractured samples and powders were coated with a thin film of carbon using a vacuum evaporator.



FIGURE 7 Hand-operated quern for milling *ishkor* ash, with a bowl of ash for one milling operation on the top in the courtyard of the Marajapov family.

was used to smother the fire within. If the flame threatened to burn through, more plants were added. Each type of plant was fired in a separate stack. The ash was milled dry in a hand quern over a period of one day and sieved to about 120 mesh (fig. 7). One workshop still retains a traditional donkey-driven mill, but it is used primarily for grinding clay, as the amount of *ishkor* glaze production is insufficient. Many workshops now compound an artificial ash composition made from commercial ceramic ingredients. The ash was then mixed at a ratio of 1.5 parts of ash with 1 part of quartz and, occasionally, small amounts of ground glass or lead compounds, then milled again. The final preparation of the glaze involves adding water to make a slurry with the consistency of cream.

Glaze Application and Firing

Wares to be glazed are usually made of a fine red clay for vessels, while the clay for tiles has a sandy, loessic consistency; representative analyses are presented in table 2. Before glazing, the object is coated with a white quartz-containing



FIGURE 8 Gofferjahn Marajapov's circular, updraft kiln with a separate, lower firebox or chamber for fuel, being investigated by Amy Vandiver. Note the quartzite slab at the rear of the firebox.

slip that has been ground and milled to a fine consistency; sometimes a quarter of a percent of an organic binder such as flour is added. After the slip has dried, an artisan paints a design on the ware using colored oxides that are often mixed with a small amount, perhaps a quarter of a percent, of flour binder and occasionally fine quartz. These additions are meant to prevent the colorants from running or blurring when the glaze is applied. The ware is allowed to air dry and is then glazed, dried again, and stacked in the upper chamber of a round cross-section, double chamber updraft kiln. Gofferjahn Marajapov's kiln is shown in figure 8; it is similar to those documented by Yoshida (1972) and Rye and Evans (1976) in Pakistan and Wulff (1966) in Iran. The kiln is fired over several days using field stubble, brush, and scrap wood in oxidizing conditions to a maximum temperature of between 800°C and 1,050°C, sometimes higher in some workshops. Tiles, plates, and small vessels are stacked on ceramic shelves supported by ceramic and occasionally iron rods that fit into holes in the kiln wall. The kiln structure and method of stacking have been excavated from archaeological

sites, the most complete of which are the kilns from Pajikent near Bukhara, and the earliest date of such kilns is late first millennium B.C.E.

Safeguarding Family Secrets

The process described above raises two anomalies that need to be addressed. First, no intermediate step consisting of a glassmaking or fritting process was described by any of the pottery masters. When the ashes of the various plants (see figs. 3–5) direct from field firing are exposed to increasingly high temperatures, the ash does not produce much glass until about 1,200°C and remains as a white to gray to black heterogeneous mass that in our replications does not produce a clear, transparent glaze when we follow the above process firing the ceramics to 1,050°C. In a sustained conversation with Ibrahim Kamillov, formerly senior ceramist in the Academy of Arts and Design of Uzbekistan, he stated that no refiring of the ash occurred, either in the firebox of the kiln or in a separate glass-fritting or melting kiln placed separately on his property, and this is his workshop's secret (fig. 9). This conversation was repeated in interviews with other pottery masters. When Kamillov was pressed further, he stated that the ash melted at 1,200°C, and he did so emphatically



FIGURE 9 Ibrahim Kamillov, the senior potter of Uzbekistan, in his home museum and showroom.

in the only English he used during our interpreter-mediated conversation, thus making it clear that no significant melting occurs during the ashing process. The anomaly, or even impossibility, consists in how a high-melting-temperature ash, when added to an even higher temperature material such as quartz, could produce a glaze, essentially a transparent glass, without any high temperature melting step. Piccolpasso, in his treatise on Renaissance Italian majolica production, tells of an intermediate fritting or partial melting step in the firebox of his kiln and even details the process with drawings (Piccolpasso, Lightbown, and Caiger-Smith 1980). The Multan potters of Pakistan employ it as well (Rye and Evans 1976).

As indicated in the soda-lime-silica phase diagram (Levin, Robbins, and McCurdie 1964: 174–75), we see that the ash-quartz compositions lie below the liquidus region of 1,100°C to 1,200°C, at compositions between 2Na₂O-CaO-3SiO₂ (34.3, 15.6, and 50 wt%, respectively, decomposition $T = 1,141^{\circ}\text{C}$) and Na₂O-2CaO-3SiO₂ (17.5, 31.6, and 50.9 wt%, respectively, melting $T = 1,284^{\circ}\text{C}$). Thus, based on our compositional and refiring studies, the ash does not melt to form a glass or glaze without high temperature. Increasing the silica content actually decreases the melting temperature toward 1,000°C. Thus an intermediate glass-melting step is required in the *ishkor* process.

Traditional family-run tile and pottery-making workshops closely guard the process they use to make *ishkor* glazes, which may explain this first anomaly. Wulff (1966) notes that competition among workshops has led each workshop to protect the future of its family's production, so straightforward information about techniques and materials was difficult to obtain for his famous treatise on Persian crafts. A large quartz or quartzite slab at the back of potter Gofferjahn Marajapov's kiln drew a noncommittal answer about fritting, although it was most likely a fritting platform rather than a target block to spread the heat, as was stated.

A second anomaly that emerged was how desert plants growing in soils with variable compositions and environments could themselves maintain a narrow range of composition, such that the fixed recipes for *ishkor* glaze with a variation of only 10 wt% SiO₂ would work every time without further testing. Often, a 1 to 15 wt% addition of lead oxide to Islamic glazes is interpreted as variability due to different workshops, for instance, with 1 to 3 percent being one workshop and 5 to 7 percent another. Workshops that produce lead glazes are thought to be different from those that produce soda-lime-silicate glazes. The unexpected practice

in Uzbek workshops, however, is to fire lead- and non-lead-containing glazes in the same kiln, though the firing of lead glazes is much more difficult because any reduction smelts a black lead residue on the surface of the glaze. Thus most Uzbek potters know both systems of glazing. Our hypothesis was that the lead compound is added to the mixed-alkali, alkaline-earth silicate ash glaze in various amounts as a flux, or melting aide, to correct for compositional variation in the ash, such that the glaze will melt and have the necessary aesthetic of brilliance and high gloss. The fritted ash is mixed with quartz and is tested to determine whether and how much lead oxide additive is necessary.

At first, this strategy of adding lead oxide is difficult to understand because we live in an industrial economy where the variations in geologic resources are eliminated through homogenization and special processing prior to use, but most Uzbek pottery workshops mine, process, and test the materials they use. Most contemporary potters in Europe and America expect to purchase uniform raw materials, and such uniformity is achieved primarily because of the large commercial and industrial scale on which these are processed and supplied to an entire market. Some modern potters even complain that the uniformity of raw materials precludes some special effects and the diversity of surface and texture that make handcrafted objects so appealing to modern sensibilities. Pye (1968) even suggests that we have lost the small-scale production processes that allow workshops to practice a “craftsmanship of risk” that makes ceramics aesthetically pleasing to view, handle, and use.

We hypothesized and found analytical evidence (table 3) to support that the *ishkor* process involves a yearly cycle with many intermediate steps for the preparation of glaze materials: gathering and ashing the plants at summer’s end; melting, milling, and testing the ash and/or the glaze; and, finally, adjusting the composition with an addition of lead oxide or another flux. The other intermediate step in preparation that potters do not generally acknowledge involves a high-temperature melt, to at least 1,200°C, of the ash cakes, followed by milling to enable rapid melting of a homogeneous transparent glaze in the kiln at a lower temperature, about 1,000°C to 1,050°C. Caiger-Smith (1973) has noted that for centuries glaze making followed the practice of glass making. Years later, at the opening of the school for traditional pottery in Tashkent, where the analytical data for the reconstructed process was presented, representatives of the twenty-five major family pottery workshops corroborated this hypothesized practice. One group even stated that



FIGURE 10 Four bowls by Ibrahim Kamillov, each showing a variation on the *ishkor* technique. Note the difference in gloss as shown in the specular reflectivity. The right side shows two bowls in traditional *ishkor* technique: the upper one with no lead oxide addition and the lower one with low lead. The left side shows two innovative bowls: the upper one with high barium oxide and the lower one with very high lead oxide content.

three melts produced optimum brilliance and clarity and later gave us samples from each of the melts.

Table 3 provides evidence of innovation and special practices in the *ishkor* glazing process in some traditional workshops. For instance, Ibrahim Kamillov’s glazed wares (fig. 10) exhibit a wide range of gloss, reflectance, and translucency that he achieves by using materials, such as barium oxide and probably borax, that are fluxes, but their use is outside the lead and *ishkor* traditions. Rye and Evans (1976) documented the use of borax in glazes among pottery workshops in Pakistan, and the low compositional totals, for example, 94 percent, imply ingredients that we cannot detect by our methods of analysis. Kamillov’s glazes also have lower iron content, evidence that he used especially pure materials, such as quartz, to promote translucency.

These data support the conjecture that ancient glazed ceramics attributed to different workshops alternatively may represent variability within one workshop. Similar variations in quality, appearance, and technology occurred in the

Table 3 Glaze Compositions of Traditional Potters and Calculated *Ishkor* Plant Ash Compositions from the Glazes

	SiO ₂	Al ₂ O ₃	Fe ₂ O ₃	CaO	MgO	K ₂ O	Na ₂ O	P ₂ O ₅	PbO	TiO ₂	CuO	CoO	MnO
Gofferjahn Marajapov #1 (one bowl)													
White, translucent	71.49	3.53	0.88	5.36	2.63	4.34	8.47	0.24	1.01	0.16	0.06	0.02	0.07
Light blue, copper	71.79	4.58	0.86	4.73	2.34	4.64	8.39	0.23	0.92	0.14	0.23	0.01	0.04
Purple, manganese	64.43	4.28	1.85	7.6	4.34	5.35	6.83	0.16	1.32	0.15	0.89	0.01	4.44
Gofferjahn Marajapov #2 (one bowl)													
White, translucent	65	4.45	1.24	5.44	3.43	4.43	14.43	0.4	0.61	0.18	0.25	0.02	0.11
Blue, copper	66.25	4.4	1.17	5	3.06	5.3	11.58	0.33	0.1	0.18	2.53	0	0.36
Purple, manganese	67.85	3.47	0.74	4.28	2.69	5.8	8.21	0.31	0	0.12	0.95	0.12	3.12
Hakkim Satimov (one bowl)													
White, translucent	65.54	4.26	1.09	5.28	3.36	4.4	11.8	0.33	0.55	0.18	0.8	0	0.42
Blue, copper	64.61	4.16	1.15	4.91	2.93	4.13	13.32	0.4	0	0.16	2.93	0	0.8
Masadallo Turapov (one plate)													
Clear	67.83	4.25	1.15	5.95	3.45	4.65	9.6	0.33	0	0.2	0.43	0.01	0.12
Purple, manganese	63.28	4.31	1.16	5.42	3.09	4.97	10.02	0.4	0.19	0.18	2.68	0.07	2.76
Blue, copper, turquoise	67.12	4.22	1.01	4.07	2.43	5.26	9.25	0.29	0.32	0.17	3	0	1.32
Ibrahim Kamillov #1 (one bowl)*													
Clear, transparent	69.95	3.5	0.27	1.85	0.18	2.61	16.04	0.04	1.22	0.09	0.28	0	0.01
Blue, cobalt	69.07	4.26	0.39	1.62	0.12	2.62	16.77	0.04	1.02	0.11	0.43	0.43	0.01
Ibrahim Kamillov #2 (one plate)*													
Blue, cobalt, transparent	66.92	4.26	0.39	1.39	0.16	2.43	16.24	0.35	0.85	0.1	4.05	0.4	0.02
Blue, copper, turquoise [†]	68.04	3.87	0.05	1.36	0.15	2.44	16.3	0.04	0.61	0.1	4.43	0.04	0.02
<i>Ishkor</i> Plant Ash Compositions Calculated from the Above Glaze Compositions^{††}													
Marajapov pot #1	58.45	6.34	1.38	9.06	4.76	7.34	12.13	0.32		0.21			
Marajapov pot #2	54.7	6.15	1.57	7.36	4.58	7.76	17.2	0.52		0.24			
Satimov	53.31	6.27	1.67	7.59	4.68	6.36	18.7	0.51		0.91			
Turapov	55.6	6.52	1.84	8.41	4.57	7.56	14.57	0.5		0.27			
Kamillov	60.03	6.59	0.75	2.45	0.25	4.06	26.02	0.06		0.02			
Average of the 57 analyses	56.42	6.38	1.44	6.97	3.77	6.62	17.73	0.38		0.33			

The above analyses were conducted by microprobe analysis (EPMA) using a wavelength-dispersive Cameca V at 15 V accelerating voltage, 10 seconds or 10,000 count, beam defocused to 10 microns. Major elements are accurate to 5%; minor elements, to 10%. Each analysis is the average of 5 to 9 points taken on a carbon-coated polished cross section.

*These glazes contain 3.7–5.36% BaO, barium oxide, an average of 4.39%. The glazes were renormalized in the table to eliminate this additive, which represents a variant technology. Note the unusually pure ingredients indicated by the low iron oxide concentration and the low MgO, which indicates a limestone source rather than dolomite.

[†]This is the only glaze to have a constantly low probe total of 93%, perhaps due to the addition of borax, B₂O₃.

^{††}A simple calculation of removing 55% of the silica, lead, and colorants should approximate the ash composition. Al₂O₃ and TiO₂ were assumed to have entered the glaze with the ash rather than the quartz, and this assumption is clearly an error but has only a relatively minor effect. Analyses of quartz sands show low alumina but some TiO₂.

central Asian ceramic workshops of the past. It is hoped that these analytical data and reconstructed practices from modern family workshops and inappropriate restorations will aid in the understanding of ancient ceramic craft and in the future conservation, preservation, and appreciation of Silk Road architectural monuments.

Summary

The analysis and reconstruction of the processes of making things are useful to the understanding of art masterpieces and archaeological artifacts and to the elucidation of human behavior, as well as some of the underlying science and technology. Such studies of material culture, when the results are used to sustain a traditional craft, also serve to preserve and project that craft and craft knowledge into the future. They serve to promote a sense of cultural identity and to develop an appreciation of cultural diversity.

Our work aimed to reconstruct Uzbek traditional tile and pottery manufacture and examine it scientifically outside the context of the family pottery workshops. For conservation science, this study helps to provide a baseline for comparison of new and old practices, and it resolves questions of process. For conservation, this study helps to provide appropriate-quality tiles for restoration, as well as objects of the appropriate technology to test new conservation treatments, methods, and materials. Our work has also helped to support establishment of a UNESCO-funded school for traditional pottery and tile production in Tashkent that is run by two of the coauthors, the Rakhimovs, and that provides durable tiles and traditional pottery of the correct appearance, durability, and colors. The school's aim is to protect and promulgate an intangible cultural property, craft knowledge, and craft practice that is at least 500 and perhaps more than 1,000 years old. By encouraging the recognition of excellent practitioners who offer an outstanding alternative to the purchase of illicit antiquities and by helping them to produce wares that are even closer in structure, composition, and appearance to the originals, we are taking some of the pressure off the looting of archaeological sites. One result, we hope, will be the continued development of wares with a strong tie to traditional technologies that will become the antiques of the future.

Acknowledgments

The authors gratefully acknowledge the discussions, guidance, and help of many friends during the research that

led to this paper, among them, Kenneth Domanik, Lunar and Planetary Laboratory, University of Arizona; Michael Barry Lane, formerly head of UNESCO-Tashkent; and the many potters and their families who generously informed this study and whose legendary reputation for hospitality is well deserved. We also wish to thank Richard Englehart and Harry Alden for help, discussions, and comments. The Institute of Geology and Geophysics of Uzbekistan kindly allowed access to their data. The authors wish to thank Neville Agnew and the staff at the Getty Conservation Institute and the Dunhuang Academy for organizing a wonderful conference and field study and for their expertise and perseverance in the production of this volume.

Notes

- 1 Below, listed according to their location in Uzbekistan and the wares they produce, are the master potters who use the *ishkor* glazing process and who were interviewed by the authors (UNESCO 2000: 103–28; Rakhimov 1961, 1968). Table 2 presents analyses of glazes from these workshops.

Ferghana Valley: This high, fertile valley where people and animals traditionally have overwintered on their travels along the Silk Road is where widespread practice of *ishkor* glazing occurs. The potters interviewed and workshops visited are as follows:

Ibrahim Kamillov (b. 1926), Rishtan (this also has a commercial ceramic factory descended from a large state factory); *ishkor* glaze and experimental glaze compositions on white-slipped red earthenware, but two sons, including Ismail (b. 1961), produce only lead-glazed, white-slipped red earthenware that is beautifully decorated beneath the glaze;

Sharafiddin Yusupov (b. 1945), Rishtan; *ishkor* glaze on white-slipped red earthenware, but son, Firdaus (b. 1974), is mainly using lead glazes;

Masadullo Turovov (b. 1952), Gurumsaray, Namangan province; *ishkor* glaze on white-slipped, underpainted, red earthenware;

Khakim Satimov (b. 1900, now deceased), Gurumsaray; *ishkor* glaze on white-slipped, underpainted, red earthenware;

Gofferjahn Marajapov (b. ca. 1939), Gurumsaray; *ishkor* glaze on underglaze painted in copper and manganese oxides over white quartz-rich slip on red earthenware body.

Tashkent area: This political and economic hub combines artistic and industrial ceramic production with a ceramic school and museums. Ash is not locally available, so the *ishkor* process, although practiced and taught, is adapted to city

practice. The potters are two of the authors of this paper and various factory researchers and managers:

Akbar (b. 1949) and Alisher (b. 1975) Rakhimov, Tashkent; coauthors and two generations of potters who use various techniques and are quite experimental in their approach, including use of *ishkor* glaze, lead glazes, and postfire paint. They run a UNESCO-backed school that teaches traditional *ishkor* technology. The senior potter of this family, Muchitdin (b. 1903, d. 1985), researched and wrote two treatises on the decorative ceramics and architectural ceramics of Uzbekistan (Rakhimov 1961, 1968). These serve as the basis for the study of Uzbek ceramics and are being translated into English. Tashkent also has factories and workshops for commercial ceramic production and for production of tiles to be used in architectural restoration.

Samarkand and Bukhara region: In this area of high tourism, potters are turning away from the labor-intensive traditional *ishkor* technology and replacing it with lead glazes and figurine manufacture. A conservation workshop and training center was found here but has since ceased operation. The potters interviewed are:

Alisher (b. 1955) and Abdullo (b. 1965) Nazrullaev, Gijduvan, Bukhara province; redware body, coated with slip and painted with oxides of Cu, Fe, Mn, Cr, and Co; a final lead glaze is applied, but their training and their father's practice was with the *ishkor* glazes;

Numon (b. 1964) and his son Inom (b. 1988) Ablakulov, Urgut, Samarkand region; redware body, partial white quartz slip, incised ornament, clear lead glaze with oxides of Cu and Fe. Through family records, they can trace ancestry of their Urgut ceramists' dynasty through nine generations to potter Abdullo (b. 1648, d. 1735).

Abduakhad Muzaffarov (b. 1955, d. 1990), Shakhrisabz, Kashkadarya province; red earthenware with partial white slip with Cu, Fe, Co, Mn oxides, and Sb complexes underpainted and coated with a lead-containing glaze;

Jabor Rakhimov, Uba, Bukhara province; Islom Muhtarov, Samarkand; and also workshops in Denau, Sukhandarya province; red earthenware body, hand-formed into birds, animals, whistles, whimsical figurines, decorated mostly with postfire paints.

Khiva, Khorezm province: A traditional religious center in the west, Khiva is home to silk, textile, and rug industries and a UNESCO-backed natural dye and rug school; it is also known for a brilliant, shiny variant of *ishkor* glaze, underpainted with detailed geometric scroll patterns, practiced mainly at Madir village. The potters interviewed are Raimberdy (b. 1909) and Odilbek Matchanov (b. 1971), who use a mixture of lead oxide, commercial glass frit, and *ishkor* glaze that they fuse and grind several times and apply on a white-slipped red body.

- 2 The ash lumps and cakes are used to make soap, glass, and glazes. They are ground and used directly to clean silk thread unspun from cocoons prior to drying and dyeing. They are used as a mordant for some dyes and sometimes as food for camels. Sometimes to make a better washing powder for clothes, calcium oxide is added as a whitener, in which case the more friable ash cake (*nura* in Arabic) is used instead of the harder and glassier form (*chinan* or *shinam* in Arabic).
- 3 The use of ashed plants by glassmakers in Herat, Afghanistan, has been filmed and reported by Robert Brill (Brill and Rising 1999). Wulff (1996) documented their use for Iranian blue glazes on white bodies; they have been documented in the ethnographic studies of glazes in Pakistan by Rye and Evans (1976: 182–83). Matson (2000) has collected similar materials and pottery from workshops in an even wider area of Southwest Asia and the Mediterranean. Kenoyer has collected ash from Pakistan, particularly the area around Harappa.

Rye and Evans reviewed studies by botanists who, in the early twentieth century, collected plant and ash specimens, such as *Salsola soda*, *S. kali*, *S. fortida*, *Halozylon recurvum*, *H. multiflorum*, and *Salicornia*, mostly in the family Chenopodiaceae.

In characterizing glazes from Kashan and Iznik, Vandiver found a wide range of chemical variability in the glazes and considered it an anomaly bearing further investigation (Kingery and Vandiver 1986). At Nippur, Iraq, in 1989, Vandiver gathered salty-tasting plants from a low-lying drainage ditch, dried them for a few days, and ashed them with the help of the cook, who used some of them as soap. From them, a reasonably formable, light grayish glass was made. In 1995 Mark Kenoyer gave me plant ash, called *sajji* in Urdu, from Harappa, Pakistan, that produced a similar analysis and glass. Matchanov in Khiva has since shown us results of his tests that show that optimum transparency and clarity are produced by melting the glass three times with a grinding step between melts. This is a process, called drygading, that traditional glass factories in America and Britain commonly used to make high-quality glass in the eighteenth and nineteenth centuries.

References

- Allan, J. W. 1973. Abu'l-Qasim's Treatise on Ceramics. *Iran* 11: 111–20.
- Amery, C., and B. Curran. 2001. *Vanishing Histories: 100 Endangered Sites from the World Monuments Watch*. New York: Harry N. Abrams in association with World Monuments Fund.
- Australia ICOMOS. 2000. *The Burra Charter: Australia ICOMOS Charter for Places of Cultural Significance (1999): With Associated Guidelines and Code on the Ethics of Co-Existence*. www.icomos.org/australia/burra.html.
- Brill, R. H., and B. A. Rising. 1999. *Chemical Analyses of Early Glasses*. 2 vols. Corning, NY: Corning Museum of Glass.

- Caiger-Smith, A. 1973. *Tin-Glaze Pottery in Europe and the Islamic World: The Tradition of 1000 Years in Maiolica, Faience, and Delftware*. London: Faber and Faber.
- Golombek, L., R. B. Mason, and G. A. Bailey. 1996. *Tamerlane's Tableware: A New Approach to the Chinoiserie Ceramics of Fifteenth- and Sixteenth-Century Iran*. *Islamic Art and Architecture*, vol. 6. Costa Mesa, CA: Mazda Publishers in association with Royal Ontario Museum.
- Grazhdankina, N. S., M. K. Rakhimov, and I. E. Pletnev. 1968. *Arkhitekturnaia keramika Uzbekistana: Ocherk istoricheskogo razvitiia I opyt restavratsii*. Tashkent: Fan.
- Khakimov, A. 1999. *Dynasty of Rakhimovs = Rakhimovlar Sulolasi*. Tashkent: n.p.
- Kingery, W. D., and P. B. Vandiver. 1986. *Ceramic Masterpieces: Art, Structure, and Technology*. New York: Free Press; London: Collier Macmillan.
- Komarov, V. L., and B. K. Shishkin, eds. 1970. *Flora of the U.S.S.R.*, vol. 6, *Centrospermae*. Jerusalem: Israel Program for Scientific Translations.
- Levin, E. M., C. R. Robbins, and H. F. McCurdie. 1964. *Phase Diagrams for Ceramists*. Vol. 1. Columbus, OH: American Ceramic Society.
- Michaud, R., S. Michaud, and M. Barry. 1995. *Faïences d'zzur*. Paris: Imprimerie nationale.
- Piccolpasso, C., R. W. Lightbown, and A. Caiger-Smith. 1980. *The Three Books of the Potter's Art = I tre libri dell'arte del vasaio: A facsimile of the manuscript in the Victoria and Albert Museum, London*. London: Scolar Press.
- Pye, D. 1968. *The Nature and Art of Workmanship*. Cambridge: Cambridge University Press.
- Rakhimov, M. K. 1961. *Khudozhestvennaia keramika Uzbekistana*. Tashkent: Izd-vo Akademii nauk Uzbekskoi SSR.
- Rye, O. S., and C. Evans. 1976. *Traditional Pottery Techniques of Pakistan: Field and Laboratory Studies*. Smithsonian Contributions to Anthropology, no. 21. Washington, DC: Smithsonian Institution Press.
- UNESCO. 1972. *Convention Concerning the Protection of the World Cultural and Natural Heritage*. Paris: UNESCO. <http://whc.unesco.org/en/conventiontext/>.
- UNESCO and Korean National Committee for UNESCO. 2003. *Guidelines for the Establishment of Living Human Treasure Systems*. Paris: UNESCO. www.unesco.org/culture/ich/doc/src/00031-EN.pdf.
- UNESCO Tashkent Office, National Commission of the Republic of Uzbekistan for UNESCO. 2000. *Proceedings of the International Symposium on Revitalization of Traditional Ceramic Techniques in Central Asia: "Blue of Samarkand," Samarkand, Uzbekistan, 6-9 June 2000*. Tashkent: UNESCO Tashkent Office [and] National Commission of the Republic of Uzbekistan for UNESCO.
- Vandiver, P. B. 2005. Craft knowledge as an intangible cultural property: A case study of Samarkand tiles and traditional potters in Uzbekistan. In *Materials Issues in Art and Archaeology VII: Symposium Held November 30-December 3, 2004, Boston, Massachusetts, U.S.A.*, ed. P. B. Vandiver, J. L. Mass, and A. Murray, Materials Research Society Symposium Proceedings, vol. 852. Warrendale, PA: Materials Research Society.
- Wulff, H. E. 1966. *The Traditional Crafts of Persia: Their Development, Technology, and Influence on Eastern and Western Civilizations*. Cambridge, MA: MIT Press.
- Yoshida, M. 1972. *In Search of Persian Pottery*. 1st ed. New York: Weatherhill.

PART SIX

Examination and Documentation Techniques



Digital Acquisition, Reconstruction, and Virtual Interpretation of Dunhuang Murals

Lu Dongming, Liu Gang, Liu Yang, and Diao Changyu

Abstract: Acquisition of information on cultural heritage is important work. In this paper, we discuss digital acquisition equipment applicable to large-scale paintings; introduce a series of criteria for acquisition of digital images and the technology for error control of image mosaicing; and present a method for 3D modeling of color statues using a 3D scanner and describe the key technology used for texture acquisition of polychromed statues. Finally, we discuss the creation of a virtual exhibit for the Mogao Grottoes at Dunhuang.

The cave temple mural paintings of the Mogao Grottoes at Dunhuang are famous throughout the world. Zhejiang University's Artificial Intelligence Institute is using image processing, virtual reality (VR), and artificial intelligence technologies to digitally document the murals for a virtual exhibit that will allow more people to enjoy the cave paintings.

The Dunhuang mural paintings and statues have high research and artistic value, but it is hard to acquire images digitally because the murals are very large and the shapes of the statues are complex. A research project was developed for digital acquisition of the painted caves and statues and for determining the best way to display the digital data in real time and in VR settings. The results of this work are presented in this paper.

Digital Image Acquisition of Dunhuang Wall Paintings

Digital photography of the Dunhuang wall paintings requires that data acquisition be factual and without subjective influences. That is to say, the photography is an engineering chal-

lenge, not an artistic production. Therefore, it is important to establish criteria to ensure that the process fulfills all requirements.

Photographic Platform

We designed a photographic platform system that is convenient and flexible and that can be used to obtain image data of wall paintings with high precision and low error. The camera is mounted on the platform, which includes a set of sliding rails, pulleys, a steel frame, and a pedestal. With this system, we can image three configurations of wall paintings: (1) where the area in front of the mural is wide, (2) where the area in front of the mural is narrow, and (3) where the mural is in a corner.

Photography of Paintings in Normal Configuration. Most large paintings can be digitally imaged using the photographic platform if they are flat and rectangular and the area in front of the mural is wide enough. Two main operations are performed during photography of paintings in the normal configuration: the camera platform moves in a horizontal direction and in a vertical direction. These two operations guarantee that the camera's visual angle covers the entire painting.

Photography of Paintings in Corner Configuration. For digital imaging of a mural located in a corner, the photographic platform is oriented to the corner, such as the vertical corner between two walls or the horizontal corner between wall and ceiling. The normal photography arrangement can be used to deal with a wall painting around the horizontal corners by adjusting the tilting angle of the camera platform. The corner photography arrangement can be used for wall paintings around the vertical corners by moving the camera platform along the main post vertically.

These photographic arrangements provide a customized design based on specific requirements and practical needs. Compared with traditional photographic methods, the design of the digital photography platform can be improved significantly for efficiency and accuracy. This platform system has been used at the Dunhuang Academy's Conservation Institute for the research work described here. The system is easily assembled and disassembled. With some modifications, the system can be used to photograph the large scale of cultural artifacts. For example, it was used successfully for the digital acquisition of a large Ming dynasty map, measuring 4.0 by 4.2 meters, that is part of collections stored in the Chinese History Archive Office.

Postphotography Processing: Error Control and Brightness Adjustment

After photography, individual images of the mural are "stitched" together to create a composite image of the entire wall painting. During the stitching process, loss of resolution and precision occurs. The main reason for this is not the stitching process itself but the photographic process. The camera's position, lens distortion, and the undulation of the wall's surface cause errors.

To control error, we first identify the camera's parameters. Using these parameters, we can calculate the relations between distortion and distance. We also can decide on the range that is valid in the separate pictures and control the errors according to our requirements.

If the distance between the camera and object is not the standard distance, as shown in table 1, one should select the standard distance for enough pixel resolution, which is a bit smaller than the real distance. For instance, if the real distance between camera and object is 2.3 meters, then the selected standard distance should be 2 meters. Based on the lens used, one can find the number of pixels that one edge of a selected pane contains, which is defined as $S_{len-opt}(L, Len)$. L is the selected standard distance, and Len is the lens used.

Table 1 Pixel* Chart for Selected Camera Lens and Distance from Object

Distance	1 m	2 m	3 m	5 m
Lens 1	750	1030	1310	1540
Lens 2	710	960	1200	13,809

* Pixel is defined as $\{S_{len-opt}(L, Len)\}$

The digital image's resolution, which must be decided before photography, must be high enough to guarantee research quality and visual appreciation. We know from practical experience that the digital image's precision should be at least 6.25 pixels per square millimeter. If the original mural is a fine line drawing, such as the *Thousand Hand Guanyin* in cave 3, the resolution of the digital image must achieve 9 pixels per square millimeter to fulfill the necessary requirements.

Last, the effects of surface undulations of the wall must be considered. Suppose the lean of the wall is not greater than θ and the required resolution is M pixels per square millimeter; we chose a lens (Len), the visual angle of which is φ ; and the resolution of the camera lens is $W \times H$.

Then, the distance (in meters) between the camera and wall is

$$L = \frac{W \cos \theta}{2000 \sqrt{M}} \cot \frac{\varphi}{2}$$

The camera platform may not move (in meters) more than

$$\frac{S_{len-opt}(L, Len) \times \cos \theta}{1000 \times \sqrt{M}}$$

every time.

Distortion always occurs during photography. There are many complex reasons for distortion, and some cannot be measured and computed accurately. We acquire camera parameters through experimentation and estimate the valid image range to reduce the effects of wall irregularities. This method can guarantee high image resolution and small error (Xu Dan, Bao Ge, and Shi Jiaoyin 2000).

Digital images often have different brightnesses, which induces a disagreeable effect in the composite image. We used a color analogy brightness method to solve this problem. First, the camera flash was used as a light source for photography and for examination of the results. Adjustments were made to even out the light distribution. Then the adjustments were adopted for the entire photographic process.

After solving the above problem, we can establish a set of criteria for the whole process. A normal digital camera and software provide high enough precision and resolution and meet the requirements for research and exhibition. Detailed criteria can be found in Shi Yihui (2002).



FIGURE 1 Reconstructed 3D wall painting with sculptural relief.

3D Digital Image Acquisition

Based on Tape Measurement. Cave dimensions are obtained by traditional tape measurement. 3D modeling software is then used to create a reconstruction of the cave.

Based on Images. There are many curved surfaces in caves apart from the polychrome statuary, such as embossments on the wall, and it is hard to acquire 3D data of these surfaces based on tape measurement. We obtained the 3D data of curved cave surfaces from images, as shown in figure 1.

To obtain 3D data of color statues, we used a 3D scanner called Fast SCAN, which is a handheld instrument that is easy to use and transport. During scanning, the 3D data can be displayed on the computer in real time and also manipulated separately. This scanner also supports output of the standard 3D file format and can handle mosaicing of several scanned surfaces. Figure 2 illustrates use of the 3D scanner.

The main disadvantages of this 3D scanner are its range limit of 1.5 meters and its inability to capture texture.

Texture Acquisition

Most 3D scanners obtain data about structure without texture, but texture is important for the imaging of statues. Photographs of statues cannot be used directly as texture.

How to make use of a set of images taken from different angles to generate a statue's texture became our research problem. This process combines knowledge of computer vision and computer graphics. We designed an algorithm that can generate a texture from multiple images (Chen Ren, Lu Dongming, and Pan Yunhe 2003). Figure 3 demonstrates the process.

Virtual Model of an Outdoor Cave Scene

Our virtual model makes use of a series of photographs to reconstruct an outdoor scene at Dunhuang. This model contains one or more sequences of photographs that support virtual visiting of the site. The user can move within the scene along the predesigned path and change direction freely at some fixed points. In this way, the user has more freedom and experiences better reality than from a panorama, although the virtual model's acquisition of data sources is less strict than with a real 3D model.

Virtual Model of an Indoor Cave Scene

The virtual model of an indoor cave scene consists of two parts: the cave's structural components and paintings and

FIGURE 2 Scanner system used to obtain 3D image of statue.

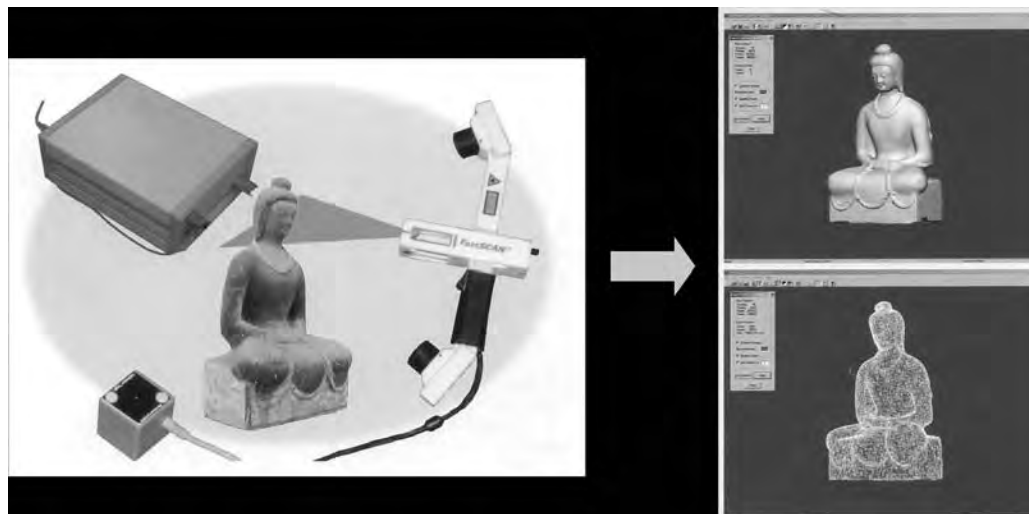

FIGURE 3 Process for generating texture on a statue's image.

the cave's statues. These two models are used to express different parts of the indoor scene.

The cave structure and wall paintings model is constructed from a traditional 3D model. This model can be modified easily and rendered in real time. Special effects can be added, such as light and shadow. Obviously, this model supports full free virtual visiting. Figure 4 is an example of a modeled indoor scene.

The statue model makes use of image-based rendering (IBR) technology. Because the 3D model of a statue is complex and the amount of data is large, it is hard to render the

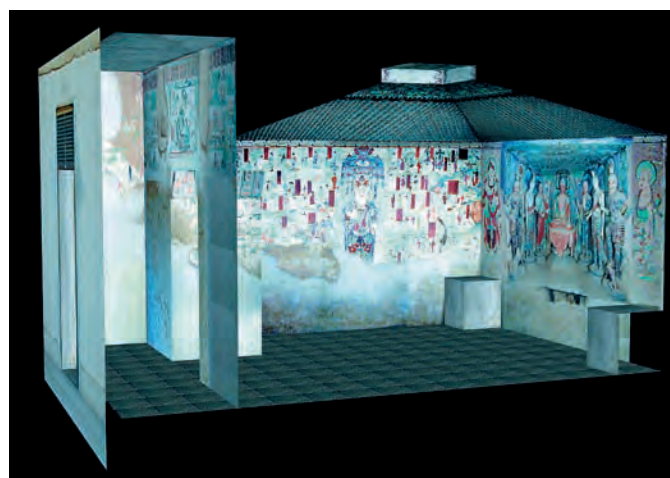

FIGURE 4 3D model of a cave interior.

3D image in real time. We make use of IBR technology and pregenerate a series of images of the statue taken from different directions. This model makes the rendering independent of the statue's complexity and depends only on the image's resolution (Zhou Tian, Lu Dongming, and Pan Yunhe 2001; Seitz and Dyer 1993–2001). Thus its requirements for computer resources are not very high, and it can run in real time on a personal computer.

The Dunhuang Caves Virtual Exhibit

Real-Time Rendering Technologies

IBR Technology. IBR technology renders a scene in real time and with high reality (Bao Hujun and Peng Qunsheng 1998). Because IBR is independent of 3D structure, the rendering time is independent of the complexity of the 3D model, but of course the 3D information of the scene is lost. IBR technology, which combines computer graphics and computer vision (Shi Jiaoying 1998), makes use of a series of images to express the 3D information of the object or scene. And during rendering, these images support the detailed information of the scene (Chen and Williams 1993). We applied IBR technology to create a panoramic image of an outdoor scene to support a virtual visit to Dunhuang, as shown in figure 5.

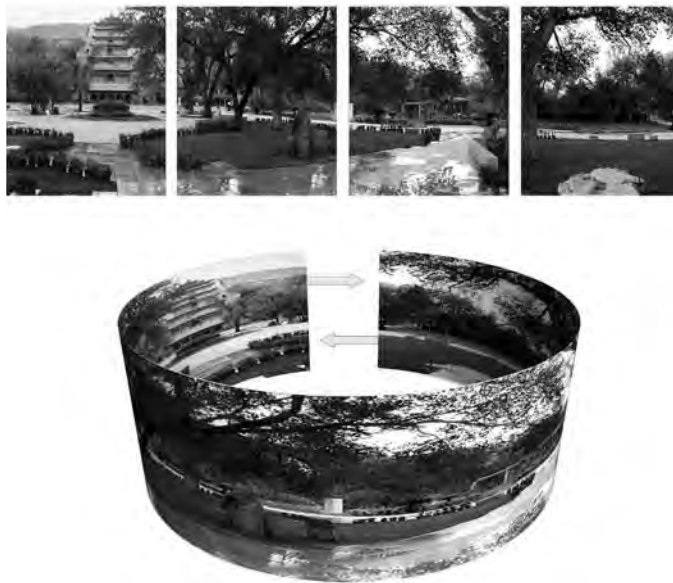

FIGURE 5 Panoramic image of an outdoor scene at Dunhuang.

Level of Detail (LOD) Technology. The advantage of the 3D model is that the 3D information is unabridged, but the triangles of the model may reach millions if the model is complex. It is a challenge to render it in real time if the model is large. Of course, we can reduce the precision of the model to reduce the rendering time to meet the requirements of real time, but this will reduce the effect. LOD technology is a good method for meeting the requirement of rendering in real time without losing the effect (Cheng Chiyi, Pan Zhigeng, and Shi Jiaoying 2001).

This method is based on a simple fact: a close object can be observed clearly, and a far object is blurry. According to this theory, we prepare a set of different precision models for one object. During rendering, the system selects the most appropriate model according to the distance between the viewer's perspective and the object.

Texture Grouping: MIP Map Technique. We also can apply the idea of LOD models to texture. Textures can be classified into several groups. During rendering, only a small number of these texture groups are close to the viewer's perspective; most groups are farther away. According to the perspective projection theory, the textures far from the viewer's perspective are scaled to very small. If every texture uses very high resolution pictures, there are two problems: this consumes a lot of computer resources and computer time; and it causes texture jitter (ragged edges) on the image.

The MIP map technology supported in Open Graphics Library (the industry standard for high-performance graphics) can solve these problems. We can define different resolutions for one texture and during rendering apply appropriate resolution texture according to the distance from the viewer's perspective. This can reduce the computing time and produce a good visual effect. This technology is very useful in our system. Because images of cave wall paintings are high resolution, using MIP map technology can reduce the rendering time significantly, without losing quality.

Reality Rendering Technology

Shadowing. A shadow expresses important relationships about an object's location and the position of the light source. Shadow is a basic element in reality graphics. Rendering reality depends mainly on perspective and shadow. So, in our system, we need shadow effects to achieve better reality.

Shadows can be computed in 3D models because they contain full 3D information. But it is difficult to compute shadow in a system using IBR because it is based on images

that lack sufficient 3D information. We designed a simple model applicable to IBR to solve this problem.

According to the position of the light, we simplify the model and compute the face oriented to the light, marked as (F_1, F_2, \dots, F_n) .

Then we compute the projection matrix for every face, F_i , marked as A_i .

$$M = (a \ b \ c \ d) \cdot \begin{pmatrix} x \\ y \\ z \\ q \end{pmatrix} \cdot \begin{pmatrix} 1 & 0 & 0 & 0 \\ 0 & 1 & 0 & 0 \\ 0 & 0 & 1 & 0 \\ 0 & 0 & 0 & 1 \end{pmatrix} - \begin{pmatrix} a \\ b \\ c \\ d \end{pmatrix} \cdot (x \ y \ z \ q)$$

$$= \begin{pmatrix} by + cz + dq & -ay & -az & -aq \\ -bx & ax + cz + dq & -bz & -bq \\ -cx & -cy & az + by + dq & -cq \\ -dx & -dy & -dz & ax + by + cz \end{pmatrix}$$

The algorithm that computes the shadow, S , on a face is shown below.

Starting with a face (a, b, c, d) :

For every light source (L_i) , for every position $P_i (X_i, Y_i, Z_i)$, and for every face (S_i) , compute the projection of every vertex to the target face; the projected vertexes compose face S_i' , let S' stand for the combination of all the S_i' :

$$S' = \cup S_i'$$

Thus to obtain the shadow for light source L_i : $S_{ii}' = S \cap S'$.

According to the intensity of every light source, we combine projection with the scene texture and generate new texture that contains shadow. Figure 6 shows the generated shadow effects on a 3D computer image of a statue using this approach. The shadow on the statue cannot be generated by a graphics method. IBR loses a lot of information, and we propose a method based on analogy and synthesis to solve this problem.

The statues at Dunhuang are mainly Buddhas, bodhisattvas, and handmaidens. Their gestures are similar, and we can classify them into several categories. Here we describe the use of the analogy-and-synthesis method to produce shadow effects for these statues.

We obtained shadow information when the light source was placed in various positions, designated as I_{s1} . Then we found the relationship between the source image, I_s , and the target image, I_d , and applied the shadow information to the target image, thus obtaining the image, I_{d1} , that has the shadow effect. To achieve this result, we had to obtain information on shadows from different light positions (from I_{s1} to I_{sn}) and construct the analogy relationship between I_s and I_d . Last, we applied shadow information to I_d and acquired target images.

In the algorithm, the analogy information source is approximate to the target under different light positions. We render images from any direction and under any light source for the acquired 3D model of a statue. We then put the rendered images into the source database and thus generate a set of analogy source images, as shown in figure 7.

FIGURE 6 Generated shadow effects on a 3D computer image of a statue.





FIGURE 7 Analogy source images for shadowing.

Last, we acquire a color transform matrix, T_{d1} , T_{d2} , T_{d3} , \dots , T_{dn} from I_d .

Bump Mapping. Bump mapping is similar to texture mapping in that both methods make the object appear more natural. Where texture mapping expresses the object's material attributes, bump mapping expresses the lighting reality by adding surface roughness. Using bump mapping, we can achieve an effect that formerly needed a large number of triangles. Bump mapping is an extension of Phong Shading. In Phong Shading, the normal to the image is used to compute

the pixel's brightness. In bump mapping, we change the angle from the normal slightly, and then the brightness of the pixel changes. Figure 8 shows a section of mural imaged, respectively, without and with bump mapping. In this example, the wall's surface roughness is generated by bump mapping, not by a large number of triangles.

Multimedia Embedded Technology

Although a virtual reality visit is impressive, making it possible to view and study every detail of a scene from different perspectives, the Dunhuang caves offer too much information to be conveyed by virtual reality alone. The cave art, which



(a)



(b)

FIGURE 8 Mural section: (a) imaged without bump mapping; (b) imaged with bump mapping, showing generated surface roughness.

contains information about the ancient civilization, will be more informative to the visitor if we combine multimedia effects such as text, sound, and video with the VR scene.

To handle this additional information within the scene, we proposed a method of embedding multimedia resources in LOD models. The models of the scene consist primarily of elements such as triangles, texture, and light. When visitors walk around in the scene, some objects are expected to be selected or picked up. They could be accessed interactively during the visit if the multimedia information could somehow be linked to the objects.

After the multimedia information is linked to objects in a scene, there must be a way to display this information to the users. Typical multimedia resources include introductory text, background music, narration, video, and animation. Background music and narration can be played by a computer's sound system. However, adding introductory text, video, and animation poses challenges. We proposed two methods to solve these challenges. First, a new window other than the virtual visit window can be used for text or video output. With this method, no change in the scene is required, but the result is not impressive. A second method is to create a specific model in Open Graphics Library by altering the texture of the models. In this way, the text, video, or animation can be seamlessly embedded in the scene, but this also has disadvantages that require changing the content of the scene. Thus it is harder to implement.

Future Work

This paper outlines the technologies and methods used to develop a virtual reality exhibit for the Dunhuang murals. These technologies as applied in our system work well. Our future research will focus on how to make use of the hardware to accelerate rendering speed and enhance reality.

References

- Bao Hujun and Peng Qunsheng. 1998. Image-based rendering technology. *Ji suan ji ke xue = Computer Science* 25.
- Chen Ren, Lu Dongming, and Pan Yunhe. 2003. [Acquiring of irregular object texture based on geometry model and photo series]. *Zhongguo tu xiang tu xing xue bao = Journal of Image and Graphics* 8 (8): 902–6.
- Chen, S. E., and L. Williams. 1993. View interpolation for image synthesis. In *SIGGRAPH 93: Proceedings of the 20th Annual Conference on Computer Graphics and Interactive Techniques*, 279–88. New York: Association for Computing Machinery.
- Cheng Chiyi, Pan Zhigeng, and Shi Jiaoying. 2001. A new representation method for multiresolution models. *Ji suan ji fu zhu she ji yu tu xing xue xue bao = Journal of Computer-Aided Design and Computer Graphics* 13 (7): 610–16.
- Seitz, S. M., and C. R. Dyer. 1993–2001. View morphing. In *SIGGRAPH 96: Proceedings of the 23rd Annual Conference on Computer Graphics and Interactive Techniques*, 21–30. New York: Association for Computing Machinery.
- Shi Jiaoying. 1998. Computer graphics and interaction technologies summarized. *Ji suan ji ke xue = Computer Science* 25.
- Shi Yihui. 2002. Dunhuang cave virtual exhibition. Master's thesis, Zhejiang University.
- Xu Dan, Bao Ge, and Shi Jiaoyin. 2000. Wavelet subspaces view distortion synthesis. *Ruan jian xue bao = Journal of Software* 11 (4): 532–39.
- Zhou Tian, Lu Dongming, and Pan Yunhe. 2001. The extended morphing method facing virtual scene rendering. *Xitong Fangzhen Xuebao = Acta Simulata Systematica Sinica = Xi tong fang zhen xue bao = Journal of System Simulation* 13 (6): 717–19.

High-Resolution Photography at the Dunhuang Grottoes: Northwestern University's Role in the Mellon International Dunhuang Archive

Harlan Wallach

Abstract: *From 1999 to 2003 Northwestern University, in a project funded by the Andrew W. Mellon Foundation, in cooperation with the Dunhuang Academy, photographically documented the murals on the walls of the Dunhuang grottoes: thirty-nine at Mogao and one at Yulin, 180 kilometers to the east. This effort took a two-pronged approach: coverage photography to acquire high-resolution digital images that captured the two-dimensional mural surfaces, and QuickTime Virtual Reality (QTVR) photography to record in situ the three-dimensional nature of the mural surfaces. This paper describes the evolution of the photographic techniques starting in June 1999 with cave 196 at Mogao and culminating in August 2002 with the completion of cave 25 at Yulin. It also describes our efforts in April 2003 to document murals in twenty caves with high-resolution surface and QTVR imagery and in another twenty caves with QTVR imagery alone. Our photographic techniques, in conjunction with a staff training program sponsored by the Andrew W. Mellon Foundation, have the potential to form the basis for systematic and comprehensive photographic documentation that will create a lasting archive of the Dunhuang grottoes for scholars and conservation professionals far into the future.*

In June 1999 Northwestern University, funded by the Andrew W. Mellon Foundation and in cooperation with the Dunhuang Academy, began a four-year project to photographically document the grotto murals at Dunhuang. At the end of that period, in April 2004, thirty-nine grottoes at Mogao and one grotto at Yulin had been completed. This effort was designed to produce a series of extremely high-resolution photographs and panoramic photography

for inclusion in the Mellon International Dunhuang Archive component of ARTSTOR. The Dunhuang Academy's research into digital documentation at Dunhuang has been in progress since about 1993, five years before our collaborative work began on the Mellon International Dunhuang Archive.

The success of our effort required flexible thinking. The ability to address the challenges posed by the varied internal architecture of the grottoes was key to the results we achieved. In almost every situation, we were required to make adaptations to our systems and to tune our equipment and techniques to provide the highest-quality results possible.

This paper briefly describes the history of our efforts to acquire high-quality photography at Dunhuang and uses the example of cave 365 at Mogao to show in detail the techniques used and how we adapted them to a specific shooting environment.

Photographing the Dunhuang Grottoes

The project had two objectives: acquisition of high-resolution images of the two-dimensional wall painting surfaces and QuickTime Virtual Reality (QTVR) photography designed to record in situ the three-dimensional nature of the mural surfaces. QTVR is a form of panoramic photography that allows 360° imaging with panning and zoom controls. Achieving these objectives was possible because of the unique photographic and processing techniques we used. These techniques work together and inform each other. Our effort was divided into three phases, discovery, research, and production.

Discovery Phase

The June 1999 trip to China to work in cave 196 during the discovery phase was unique in several ways. To begin with, the photographic team had not previously visited the grottoes, and this trip was as much a scouting venture as an attempt to successfully capture an entire grotto. This was the only trip during which all the photography was shot on 100-speed Kodak Ektachrome film. A Nikon F5 camera was used with a variety of fixed focal length lenses. The exposed film from this discovery phase photography was carried back to the United States unprocessed. The entire cave 196 was shot without seeing a single processed image of any of the two thousand or so source images we made before leaving China. On our return to the United States, the images were processed and transferred to a Kodak PhotoCD.

The camera platform for supporting and manipulating the photographic equipment was crude. We adapted standard steel scaffolding with auto poles, iron bars, and super clamps and then mounted the entire structure on casters to facilitate moving about in the cave.

Illumination was provided by a portable battery-powered Lumedyne system. This strobe-based illumination was the only aspect of our system to remain consistent throughout the entire process. Within one year, the process would completely evolve from an analog/film-based methodology using off-the-shelf scaffolding into one based on a custom-designed and -fabricated camera platform and an image acquisition system almost entirely dependent on digital camera devices.

Research Phase

The next two trips were taken in November 1999, to photograph caves 16, 17, and 148, and in March 2000, to photograph cave 146. The approach taken during these trips was the basis for all the core innovations we would later implement in the production and completion phases. The two significant changes that occurred in our acquisition efforts took place during the November 1999 trip. These changes involved the introduction of a high-resolution digital camera, specifically the Kodak DCS 660, and high-intensity HMI lights to illuminate the entire cave at once for the QTVR photography.

The Kodak DCS 660, one of the first high-resolution digital field cameras, gave us what is now a familiar benefit of digital photography: the ability to preview the image as it is acquired. Separate images can be seen immediately and can also be “stitched” together in the cave to verify quality,

exposure and focus, the geometry of image sequence, and the order and spacing, and the whole can be assembled into the final textures in the field.

Cave 148 was the first grotto in which we used high-intensity, HMI-style lighting to provide full cave illumination for the QTVR photography. QTVR photography enabled us to capture the three-dimensional nature of the grotto interior in a way that would most closely replicate what visitors would experience if they were actually standing in it. The HMI lights were pointed at reflecting “bounce” cards placed on the floor. The light bounced from these cards closely mimicked exterior daylight coming in through the entrance. This light, however, was completely controlled, and images could be acquired independently of the vagaries of actual daylight.

Caves 16 and 17 were photographed in November 1999. Due to its very small size, cave 17 (the Dunhuang Library Cave) could be shot only with a handheld camera and with a tripod. In contrast, the extremely large cave 16 required a mechanical system that would constrain and control the camera movement and allow quick adjustments. The solution was to add rollers to the camera platform so that it could be moved along a track.

This rolling scaffold system made it possible to control the camera movement as it rolled across the front of a wall mural as well as to raise the platform in controlled and measurable increments. These were the core innovations that were implemented in our photographic acquisition techniques.

Production Phase

Starting with the trip in October 2000, the process accelerated. This trip resulted in imagery from caves 249, 285, and 158, which were photographed in three weeks. With the addition of a second rolling scaffold system, two teams could work simultaneously in different caves. A third team worked in a third cave, shooting the QTVR photography. In this way, we doubled the production of the entire first year of the project. At this point manpower was a key issue, and staff from the Dunhuang Academy worked with each of our groups, thus improving the speed and efficiency of our efforts.

The participation of the academy’s leadership and staff, who handled administration tasks in addition to doing the actual photography in the grottoes with us, was an integral part of our process. This collaborative approach defined the work mode for the next two years. A series of three-week, three-grotto campaigns followed: April 2001 (caves 45, 61,

254), August 2001 (caves 329, 419, 428), and October 2001 (caves 156, 322, 420).

In August 2001 we upgraded our digital equipment. This was a period of rapid technological advance during which the Kodak DCS 660 had become obsolete. Two Hasselblad ELP camera bodies with the Kodak ProBack were added to our camera equipment. This system allowed us to capture individual frames at much higher resolution, essentially three times more data, thereby decreasing the number of frames needed to cover a wall mural. It also made the postproduction assembly of images quicker.

By April 2002 we had enough equipment and trained team members to have four photography teams working simultaneously. On the final campaign, from July to August 2003, we shot two grottoes, cave 465 (at Mogao) and cave 25 at the Yulin site. The final stage of the project for QTVR photography was in April 2003, when twenty grottoes at Mogao were photographed over a two-week period. For this work, we had upgraded our digital cameras to Nikon D100 bodies mounted on Kaidan spherical QTVR shooting heads.

In general, the in-cave illumination for QTVR photography was achieved with two sources: large HMI lights to simulate daylight and the Lumedyne strobe lights to raise the level of ambient light immediately surrounding the camera. The balance of these two light sources modeled the chamber and provided even illumination for murals closest to the camera.

Staff Training

Throughout the four-year duration of the project, training of our Chinese colleagues was an important component. One training session occurred independently of each of the acquisition trips through August 2001. At the grottoes, two shooting teams worked side by side: one team was crewed by Mellon International Dunhuang Archive personnel with support from Dunhuang Academy staff, and the other consisted of only Academy staff. This made it possible to

assemble a team of Chinese personnel skilled in the project's photography techniques who would later be able to use them in Dunhuang, as well as at other sites in China. The dissemination of these jointly developed photographic techniques into areas that may provide documentation and preservation of the vast cultural resources of China will, we hope, be the final legacy of this project.

Conclusion

In a follow-up to our project, the Dunhuang Academy is exploring the use of high-resolution images for the planned visitor center. Both 2D and 3D images will be used in presentations as part of an educational program. It is hoped that this extension of our work will lead to other new ways of using imagery of this resolution and quality in research and in education, as well as form the basis of new ways to explore, understand, and preserve similar sites.

Acknowledgments

This project could not have happened without the vision, support, and guidance of William G. Bowen, president of the Andrew W. Mellon Foundation; Henry Bienen, president of Northwestern University; and Dunhuang Academy director Fan Jinshi and deputy director Li Zuixiong. My two direct associates at the Dunhuang Academy, Liu Gang and Sun Hongcai, who worked with us and supported our efforts at every step, were integral to the success of this work. The attention and focus of Don Waters, our program officer at the Andrew W. Mellon Foundation, were invaluable during all aspects of this project. My two principal American collaborators on the development of the imaging techniques were James Prinz, who accompanied me on every trip, and Stefani Foster, who was one of our principal photographers and trainers. Sarah Fraser, project director, whose original research on three of the caves was the project's initial inspiration, was invaluable to the success of the project.

Dunhuang Grottoes Conservation and Computer Technologies

Pan Yunhe, Fan Jinshi, and Li Zuixiong

Abstract: *Computer technologies play an increasingly important role in conservation work. They are being implemented in a collaborative project between Zhejiang University and the Dunhuang Academy, which aims to establish a computer-assisted conservation program that entails digital documentation, virtual reconstruction and display, and simulation of pigment color change in the wall paintings of the Mogao Grottoes. In adapting these technologies, several new techniques have been developed for digital documentation and graphic processing. This paper gives an overview of these innovations.*

The Dunhuang area is home to three sites under the Dunhuang Academy's responsibility: Mogao Grottoes, Xiqianfo Grottoes, and Yulin Grottoes, comprising 552 caves with wall paintings and sculpture. This treasury of arts faces the danger of deterioration and fading and the collapse of the cave temples (Li Zuixiong and Liang Weiying 1994: preface). Conservation of this treasury is thus urgent but overwhelming in scale. Traditional conservation methods are irreversible and sometimes unpredictable in their long-term effects. For these reasons, they require a lengthy process of evaluating methods and materials, which may significantly limit their application and scope. By comparison, computer technologies have the advantages of efficiency and repeatability and are risk-free. They can effectively aid traditional conservation methods in documenting, archiving, data analysis and management, and visual replication and have great potential for conservation of the grottoes in the Dunhuang area.

Over the past decade, we have been involved in the collaborative projects Integration of Multimedia, Intelligent

Graphics, and Conservation of Arts, funded by the National Natural Science Foundation of China (1998–2001), and Digital Documentation and Virtual Display of Threatened Cultural Properties, funded by the Key Technologies R&D Program (1996–99). These projects have applied computer technologies to document data, replicate wall paintings, and develop virtual displays. They have resulted in the Virtual Navigation and Wall Painting Restoration System of the Dunhuang Grottoes, which was exhibited at the World's Fair in Hanover, Germany, in June 2000, and the book *Real and Virtual Dunhuang* (Zhejiang University Press, 2003). They have also resulted in three patented designs and programs and the development of the virtual tour system of Dunhuang Mogao Grottoes, the computer-assisted replication and restoration system of the Dunhuang wall paintings, the computer-assisted protection and restoration system of grottoes, and the program to create and display the Dunhuang style designs. The results of these projects have also been presented at conferences and published in articles. This paper presents a number of major technical innovations generated by these projects.

Digital Documentation of the Dunhuang Grottoes

Digital documentation can contribute significantly to the conservation, research, and tourism development of the three sites constituting the Mogao Grottoes. The goal of this project is to build computer-based virtual models of the grottoes, thereby providing high-resolution digital data for information sharing, conservation, scholarly research, art appreciation, and development of tourism. In adapting digi-

tal technologies and computer graphics to the two major forms of art, wall paintings and painted sculptures, we have designed the two documentation programs described below.

Wall Paintings

Wall paintings at Mogao alone measure 50,000 square meters in area. Because most of the paintings are quite large, we divide a wall surface into many regions and shoot area by area so as to acquire high-resolution photographs using flash illumination, which, when patched together, produce a high-resolution image of the whole. The digital cameras are high resolution and high quality. So far several dozen grottoes have been photographed.

There has been no systematic and standardized operational procedure developed for photographing wall paintings. A traditional method is to shoot from preselected positions after mapping the target wall, which results in photographs that are difficult to piece together. To overcome this problem, new shooting platforms and a new operational procedure have been designed, both of which have been patented.

New Shooting Platforms and Procedure

There are three types of wall paintings: large and unobstructed, small or obstructed (by other objects such as altars),

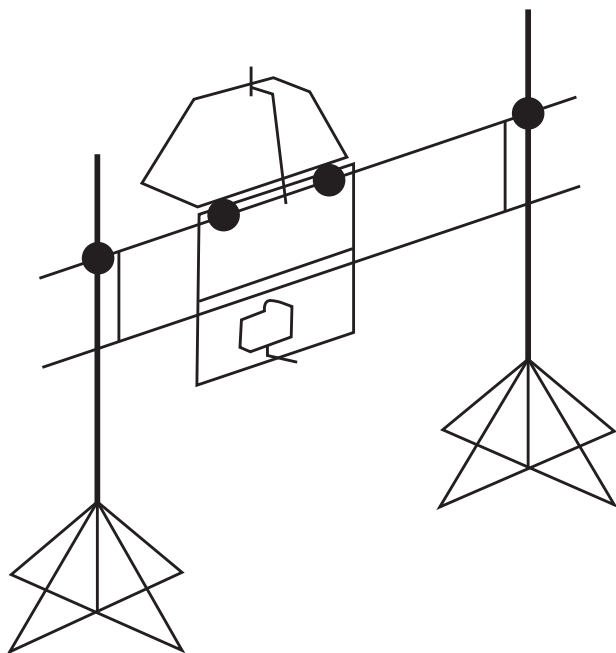

FIGURE 1 Shooting platform, designed by Zhejiang University, 2001, Patent no. CN 01209426.9.

and corner. A shooting platform has been designed for each type. The platform for the first type consists of a sliding board on two rails, two side frames that are affixed to the sliding board, and a frontal frame that is attached to the two side frames. The frontal frame is an independent unit holding a camera and a flashlight and can be used on the second and third types of platforms. The rails are laid parallel to the wall, and the camera and flashlight can move horizontally by sliding the board. The frontal frame can slide on the side frames vertically. The camera and flashlight can move synchronically both horizontally and vertically while maintaining the same distance to the target wall. For the second type, the frontal frame is attached to two horizontal beams but can slide horizontally on them. The two horizontal beams are attached to two standing and fixed poles and can slide vertically. So eventually the camera and flashlight can move both horizontally and vertically (fig. 1). For the third type of fresco, the frontal frame is attached to one standing and fixed pole and can slide vertically on it.

The working procedure consists of the following steps:

1. Measure the wall and divide it into regions, the sizes of which can be calculated based on the desired resolution.
2. Install flashlight and camera on the shooting platform.
3. Adjust camera and flashlight.
4. Test shooting.
5. Begin shooting and record shooting settings, such as position, serial number, resolution, and light.
6. Store photographs on the computer.
7. Patch and edit photographs.

Resolution loss is expected during digital documentation. The loss can be caused by uneven walls, projection distortion, and change of shooting position. It can also result from the fact that resolutions of individual photos vary, and the resolution of the patched photograph is identical to the lowest one. To minimize this loss, each cause is examined, and a course of action to minimize its effect is determined, as follows:

1. We determine the distortion of a lens by testing it. With this we can correct the distortion of each photograph.
2. We select the most cost-effective resolution for the project. Digital documentation demands high

resolution, which not only increases the workload but also consumes computer memory resources. Based on our experience, a resolution of 6.25 pixels per square millimeter is sufficient for documenting most wall paintings, but for those that were painted with fine lines, such as the thousand-arm Avalokitesvara in cave 3 at Mogao, the resolution must be raised to 9 pixels per square millimeter to achieve adequate photographic quality.

3. Finally, we consider the inclination of a wall. In this case it is necessary to determine the angle of deviation from the vertical, and knowing the camera and lens specifications, we are able to develop a complete algorithm for calculating the compensation required.

Painted Sculptures

For 3D objects such as painted sculptures, we use a 3D scanner to acquire their geometric models with millimeter accuracy. Operational procedures have also been designed for painted sculptures of various sizes and various positions. The currently available scanner, however, cannot record the rich color information of painted sculptures. To overcome this defect, we take digital photographs around painted sculptures and put them on the scanned monochrome models using a method previously developed that employs three types of algorithms: projection transformation, triangle morphing, and mosaicing (Chen Ren, Lu Dongming, and Pan Yunhe 2003: 902). The patched photograph is usually not seamless because it is difficult to maintain the exactly identical positions and lights and shades. So we use patching and blending, the Szeliski program in particular, to harmonize them.

This method takes into consideration the shooting conditions during the mosaicing and blending processes and has advantages, we believe, over the texturing method advanced by the Italian National Research Council in that it produces a complete surface of the object that is visual and unambiguous. We can revise texture and edit the image directly, which is useful for virtual restoration of objects and the construction of a multimedia database.

Virtual Display

An Integrated Model

The Virtual Navigation System of the Dunhuang Grottoes is intended to include a broad spectrum of information,

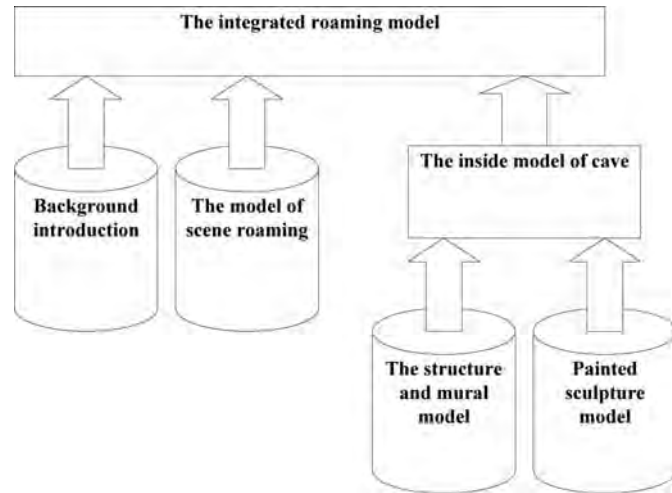

FIGURE 2 Integrated model of the Virtual Navigation System of Dunhuang Grottoes, created by Zhou Tian, 2002.

including external environments, architectural structures, wall paintings, painted sculptures, and an audio information system. We have proposed a metamodel to integrate the models designed for the above-mentioned tasks. The framework of the metamodel is shown in figure 2.

Rendering Based on the LOD Group Model

Rendering is a process of transforming still photographs into motion video, and for this purpose we use the LOD (level of detail) group model. This modeling program first divides the triangles in a 3D model into several groups, which are linked with each other (Diao Changyu 2003: 22). The division of LOD groups is shown schematically in figure 3.

During the rendering process, each group of triangles is textured with one level of detail. The LOD of each group is determined by the distance between the group and the viewpoint. The group nearer to the viewpoint is given the higher complexity and resolution; the one farther from the viewpoint is given the lower complexity and resolution. The working process of the grouping LOD model is shown in figure 4.

Computer-Assisted Wall Painting Replication

Conventional Method

The conventional working procedure for documenting the condition and copying the wall painting consists of five steps: (1) shooting positive photographs of the painting; (2) magni-

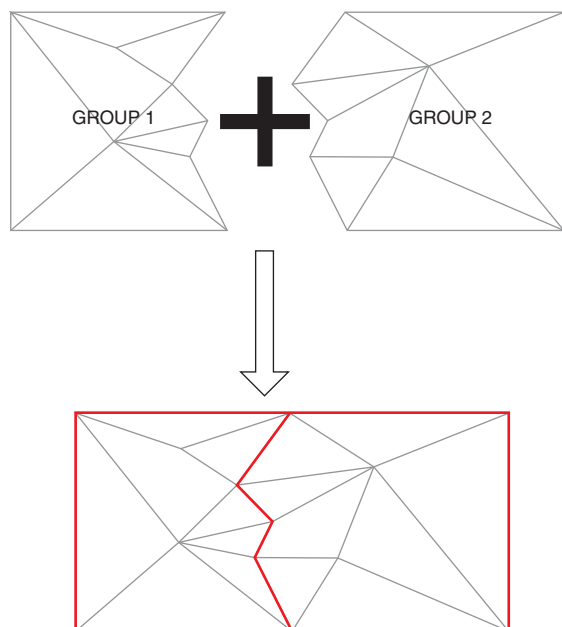

FIGURE 3 Grouping LOD model, created by Diao Changyu, 2003 (top: seen up close; bottom: seen at a distance).

fying the positive film to the original size; (3) editing the film based on the original; (4) copying a line drawing onto a piece of paper; and (5) coloring the drawing based on the original. The production of the copy is extremely time-consuming and labor-intensive. An area of a few square meters may take a year to complete. Coloring also requires knowledge in the fields of chemistry, physics, and art history and is an equally sophisticated process; a casual mistake would cause a great loss of time and labor.

Key Techniques of Computer-Assisted Replication

Intelligent computer techniques enable us to overcome the limitations of the conventional method in both line drawing and coloring as described below.

Computer-Assisted Drawing. Conventional algorithms of partitioning images and acquiring line boundaries cannot satisfy artists' demand for detail. The computer may enable us to acquire more realistic replications of images. To explore this potential of the computer, we have conducted a number of technical studies. First, we used accurate boundary acquiring techniques. The commonly used techniques for partitioning images are threshold, edge detection, region growing, and recursive algorithm. These methods can produce good pictorial effects when used to segment gray images, but when

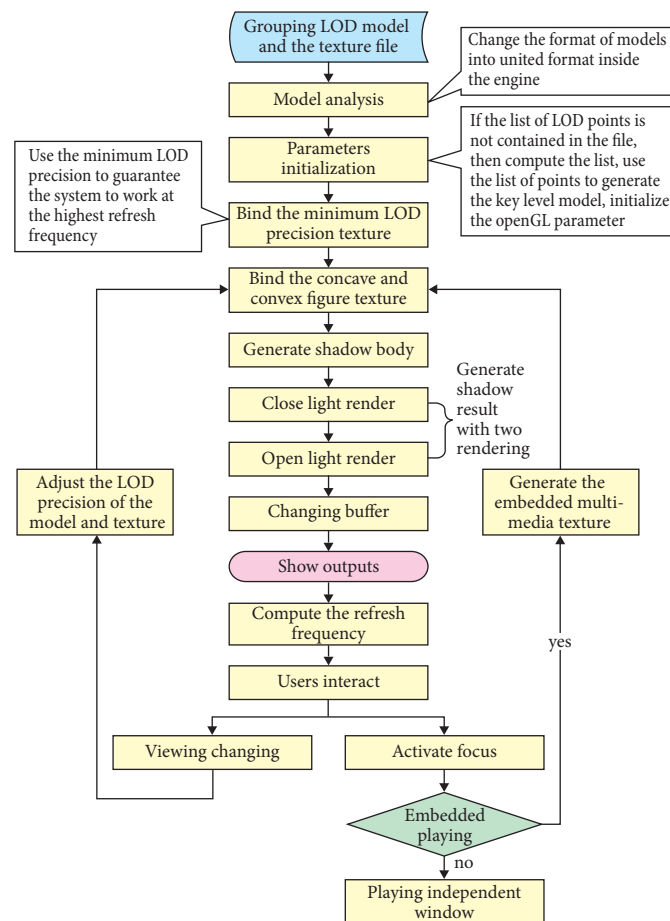

FIGURE 4 Rendering of engine process of the grouping LOD model.

they are used to segment color images, the effect is not satisfactory. In most cases, we cannot obtain the ideal effect by using one method. We were able, however, to improve the effect by applying variously combined segmentation methods to different target regions (Li Xiangyang et al. 1998: 637), thereby effectively determining edge detection on the wall paintings (Wei Baogang et al. 2001: 60).

Next, damaged or lost areas are “replaced” with pictorial models (Wei Baogang and Pan Yunhe 1998: 260). We have built up a database of vector graphics of line drawings and colors produced by contemporary Dunhuang Academy artists who use traditional copying methods. From this database, the best selection is made for replacing or mending the damaged areas. Last, the lines are refined by alternately using the well-developed vectorizing technique and interpolation algorithm to simulate line drawings of various styles.

Computer-Assisted Coloring. To color the computer-generated line drawings, pattern recognition, computer graphics, and nonrealistic drawing techniques are used. First, the target areas are determined. Then the required pictorial elements and specific target regions for coloring are identified. Next, the correct colors are selected from the database using intelligent search. Based on the distinctive coloring technique and brushstrokes of Chinese paintings, we have developed models that imitate conventional brushstrokes. With these models, the spirit of the brushwork of the paintings is re-created to the extent possible.

Conclusion

It appears that the application of digital technologies and computer graphics is beneficial to the conservation of Dunhuang art. In addition, adaptation of computer technologies to the wall paintings inspires the development of new graphic techniques. In the meantime, computer technologies greatly assist conservation methods and can be used extensively in the interpretation of the sites and their art to visitors.

Acknowledgments

The authors wish to thank Diao Changyu for assistance with revisions to the manuscript.

References

- Chen Ren, Lu Dongming, and Pan Yunhe. 2003. [Acquiring of irregular object texture based on geometry model and photo series]. *Zhongguo tu xiang tu xing xue bao = Journal of Image and Graphics* 8 (8): 902–6.
- Diao Changyu. 2003. LOD group models and rendering algorithms. Master's thesis, College of Computer Science, Zhejiang University.
- Li Xiangyang, Lu Dongming, Pan Yunhe, and Z. Hua. 1998. Content and semantics-based image retrieval for the preservation, restoration, and pattern creation of Dunhuang frescoes. In *VSM98: Futurefusion: Application Realities for the Virtual Age: 4th International Conference on Virtual Systems and Multimedia, VSM '98, November 18–20, 1998, Gifu, Japan: Proceedings*, ed. H. Thwaites, 636–41. Burke, VA: IOS Press.
- Li Zuixiong and Liang Weiying. 1994. *Li Zuixiong shi ku bao hu lun wen = A Collection of Papers on Cave Conservation*. Lanzhou: Gansu min zu chu ban she.
- Wei Baogang, Lu Dongming, Pan Yunhe, and Yang Yun. 2001. Interactive image segmentation using multiple color spaces. *Journal of Computer Science* 7: 770–75.
- Wei Baogang and Pan Yunhe. 1999. Frame and rule-based restoration of colors of ancient frescoes. *Journal of Pattern Recognition and Artificial Intelligence* [in Chinese] 12 (3): 258–64.

Multispectral Imaging for Easel and Wall Paintings

Haida Liang, David Saunders, John Cupitt, and Christian Lahanier

Abstract: *As part of the European Union-funded CRISATEL project, a new high-resolution multispectral imaging system has been developed for the efficient, direct imaging of paintings. The CRISATEL camera, fitted with thirteen band-pass interference filters covering a wide spectral range, from ultraviolet to near-infrared (400–1,000 nm), is capable of capturing an image of 12,000 by 20,000 pixels. The camera was tested with a new pigment chart developed as a potential museum standard as it has a wider color gamut and is more representative of the pigments found in easel and wall paintings than the Macbeth ColorChecker chart used in the past. The major improvements over the VASARI multispectral system, developed previously at the National Gallery, is the potential portability of the new camera and the possibility of reconstructing the spectral reflectance per pixel of a painting rather than calculating simple colorimetric data under a given illuminant.*

In this paper, we concentrate on a laboratory version of the CRISATEL camera to assess its application to the imaging of a wall painting fragment. The multispectral data for this wall painting have been used to reconstruct color images of the painting as it would appear under different illuminants, daylight and candlelight in this instance. The spectra for each pixel have been reconstructed, and comparison with measurements made by conventional spectrophotometric means indicates good accuracy. The technique thus has potential for increasing the accuracy of long-term color monitoring over the entire surface of a painting using a noncontact technique. A series of pigment standards have also been imaged using the system, and their spectral reflectances have been reconstructed. These provide the basis of a library of spectra that could be used in pigment identification; the technique was applied successfully to four areas of the wall painting fragment studied.

Since the late 1980s, the National Gallery in London has been engaged in the development of multispectral imaging systems. The initial aim of this research was to monitor long-term color changes in paintings, but the scope of the research has since expanded to encompass accurate color imaging for conservation documentation and, most recently, to investigate the potential of multispectral imaging as an additional method to assist in pigment identification. Although much of this research has centered on easel paintings, the techniques apply equally to wall paintings. We have recently begun to explore the challenges of applying the technology to the examination of paintings on walls.

These imaging systems have been developed through a series of pan-European research initiatives, beginning with the VASARI project,¹ which produced the first multispectral imaging system to examine paintings, based on a monochrome digital camera and a filter system that provided seven bands across the visible range from 400 nanometers (nm) (blue) to 700 nm (red) (Burmester et al. 1992: 201–14; Saunders and Cupitt 1993). The VASARI system made efficient colorimetric measurements on the surface of the painting using a series of targets to calibrate the seven-band data. The color information was stored as standard CIE Lab color coordinates (CIE 1978), and although the seven-band data were also archived, no attempt was made to reconstruct the spectra. The color accuracy was determined by comparing the color data obtained from imaging the twenty-four colors of the Macbeth ColorChecker chart with color data for the same patches measured spectrophotometrically. Over the course of ten years, the calibration process was refined to reduce the color error to the point where it was close to a just-visible difference (Martinez et al. 2002). The main drawbacks

of VASARI systems are that they are more or less immovable once installed, they can measure only smaller paintings, and they were mainly used for producing accurate color images rather than for deriving convincing reconstructions of the reflectance spectra on a per-pixel basis.

The European Union-funded CRISATEL project developed a new high-resolution multispectral imaging system to image paintings and other 2D objects (Lahanier et al. 2002).² The CRISATEL JumboScan camera, fitted with thirteen band-pass interference filters, covering a wide spectral range from visible to near infrared (400–1,000 nm), is capable of capturing an image of 12,000 by 20,000 pixels. The scanner was tested with a new pigment chart developed as a potential museum standard. The new chart covers a wide color gamut and is more representative of the pigments found in modern and old master paintings than the Munsell ColorChecker chart used previously. The major improvement of CRISATEL systems over the existing VASARI multispectral system developed previously at the National Gallery is the potential for reconstruction of the spectral reflectance per pixel of a painting rather than simple colorimetric data under a given illuminant.

The results presented in this paper were obtained using a laboratory version of the CRISATEL system constructed at the National Gallery (referred to here as the NG CRISATEL system) during the development of the large CRISATEL JumboScan camera in Paris (Ribes et al. 2003). The NG CRISATEL system is based on the same set of thirteen filters used with the full CRISATEL system and a simple commercially available camera (Haida Liang, Saunders, and Cupitt 2005).

The NG CRISATEL Multispectral Imaging System

The laboratory version of the CRISATEL multispectral imaging system in use at the National Gallery is based on a monochrome digital camera, Zeiss AxioCam, with a cooled CCD sensor and fourteen-bit electronics fitted with a filter wheel holding the same thirteen interference filters used in the JumboScan. The CCD detector in the camera is a Sony 1,300 by 1,030 pixel sensor with pixel size of 6.7 micrometers, capable of sampling at 3,900 by 3,090 pixels in micro-scanning mode (fig. 1). The lighting system consists of two identical 82-volt, 410-watt tungsten lamps connected through optical fibers to six outlets that are evenly placed around the optical axis, illuminating the target at roughly 45°. The filter wheel is placed between the detector and

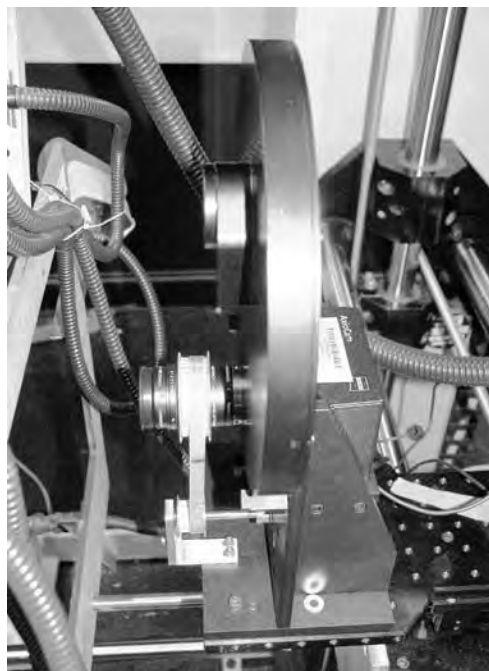

FIGURE 1 NG CRISATEL multispectral imaging system in use at the National Gallery, London.

the Schneider Componon-S lens (80 mm focal length). The camera needs to be refocused with each change of filter because of the variation in filter thickness. This is achieved by adjusting the lens focus automatically. The closest object distance gives a resolution of 20 pixels per millimeter on the painting. An f-number of 5.6 was chosen to give the highest efficiency without vignetting and distortion. For use in the laboratory, both the camera and the lights are mounted on an X-Y scanning stage such that the illumination and viewing geometry are fixed over the entire scan.

The response of the CCD was found to be linear over almost the entire dynamic range, and the mean dark current, which corresponds to the thermal noise of the device, was found to be constant with exposure time. Each series of twelve dark frames was taken at the same exposure as for the target frame, to produce master dark frames to be subtracted from target frames. Exposure times per filter were adjusted such that the frames were not saturated and the total counts accumulated were the same for each filter when a perfect white target (i.e., 100% spectral reflectance across the channels) was imaged.

A white Teflon (PTFE) board was used for flatfielding, that is, correcting the inhomogeneity of the illumination

and the variation in pixel-to-pixel response of the detector for each filter. A Spectralon white from LabSphere was used as a white spectral target to correct for the spectral response of the system. The central area of the dark-subtracted and flatfielded image of the spectral white target was then used to spectrally calibrate the target frames.

Assessing Quality of Spectra and Color

To check the accuracy of the spectra measured with the NG CRISATEL system, two kinds of pigment-based color charts were imaged: (1) the Macbeth ColorChecker DC chart with 240 color and gray scale patches and (2) a chart, developed for the CRISATEL project by the French pigment manufacturer Pébéo,³ with 117 color and gray patches duplicated in both varnished (glossy) and unvarnished versions (the Pébéo chart is more representative of artists' pigments and is a potential museum standard). A Macbeth ColorChecker chart with only twenty-four color and gray patches was also used as a routine test chart for each painting scanned. While the commercially available Macbeth charts are pigment based and have a wide color gamut, they were thought to be unrepresentative of the spectral reflectance of pigments found in old master paintings.

For camera systems designed to reproduce accurate color images of the original, there is a standard colorimetric measure of the quality of the system that gives a clear indication of the significance of a color difference to a human observer, namely, a mean ΔE for a color chart (a $\Delta E \sim 1$ usually means a just-discernible color difference for a human observer). In the case of a multispectral system designed to reproduce not only accurate color but also accurate spectra, an assessment of a combination of a mean ΔE and a mean rms (root mean square) spectral difference between the measured or reconstructed spectra and the "standard" spectra of a color chart measured with a spectrophotometer is needed. These two parameters are used here to judge the quality of our system. In particular, color difference will be expressed in terms of ΔE_{00} under D65 illumination and viewed by a 1931 2° CIE standard observer (Luo, Cui, and Rigg 2001), and rms spectral differences will be calculated between 400 and 700 nm at 10 nm intervals unless otherwise specified.

A simple cubic spline was found to be sufficient to recover the spectral reflectance from multispectral images (fig. 2). Table 1 summarizes the differences in terms of rms spectral differences and ΔE_{00} between the spectral reflectance obtained from the NG CRISATEL multispectral sys-

Table 1 Spectral and Color Differences, CRISATEL System vs. Minolta cm2600d Spectrophotometer ^a

Color Chart	Spectral rms Difference	ΔE_{00}
Macbeth	0.014	1.2
Macbeth DC	0.017	1.6
Pébéo unvarnished	0.016	1.9
Pébéo varnished	0.017	1.8

^aMean differences between the CRISATEL system interpolated spectra and those measured with the Minolta cm2600d spectrophotometer.

tem and those from the Minolta spectrophotometer for the various test charts. The color difference was found to be 1.2 and 1.9 ΔE_{00} units for the various test charts. In this case, the Minolta measurements were made by collecting reflected light from a circular area of 3 mm in diameter, and the multispectral measurements were averaged over an area of 3.5 by 3.5 mm². The differences listed in table 1 include both intrinsic differences between the multispectral system and the Minolta spectrophotometer and random measurement errors and interpolation errors. Some of the intrinsic differences between the systems reflect a limitation in the multispectral system; for example, unlike a spectrophotometer, the multispectral system is an open system in which each measurement area is affected by scattered light from its surroundings. On the other hand, the spectral and color differences that resulted from the difference in illumination and viewing geometry between the systems are not a limitation of the multispectral system. In other words, if we can find a spectrophotometer with the same illumination and viewing geometry as the multispectral system, then the spectral and color differences will be less than those listed in table 1.

Assessing Instrument Stability

The stability of the instrument is important for the purpose of spectral/color monitoring. The stability of the NG CRISATEL system was checked over a period of six months in three independent experiments using a small Macbeth ColorChecker chart of twenty-four color and gray patches. The relative spectral/color differences between the experiments were 0.95 ΔE_{00} unit and a mean rms spectral error of 1.3. The color differences are visually insignificant to a human observer; that is, the CRISATEL multispectral system is sufficiently accurate for the purpose of monitoring color or spectral changes.

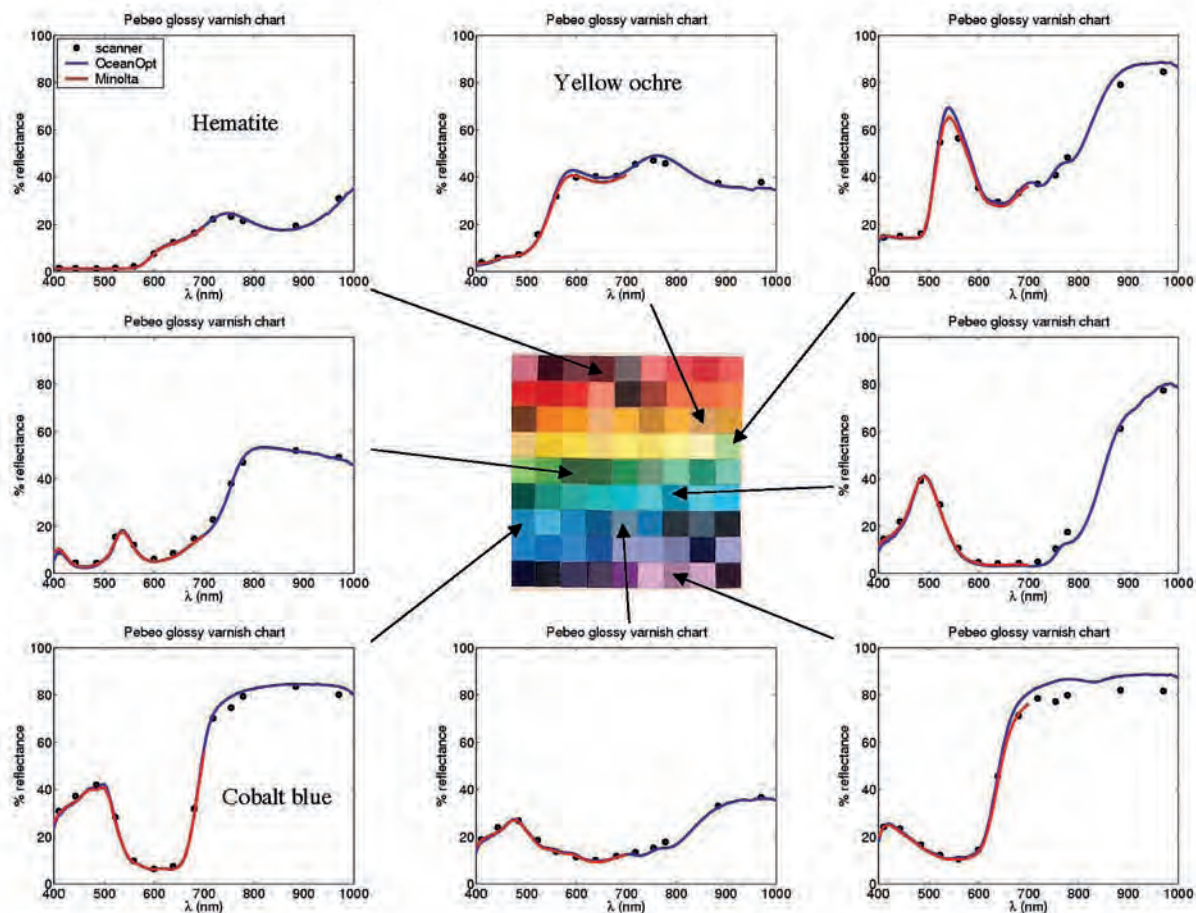

FIGURE 2 Spectra for eight patches from the Pèbeo glossy color chart measured with the Minolta cm2600d and Ocean Optics spectrophotometers and compared with data from the NG CRISATEL multispectral scanner.

Imaging Wall Paintings with the NG CRISATEL System

Although the CRISATEL multispectral systems were developed for use with European easel paintings, we have also used the NG CRISATEL system to image a detached wall painting fragment to demonstrate its applicability to such painted surfaces.

The multispectral system was used to image a fragment of a fifteenth-century Tuscan detached fresco painting (*Heads of Angels*, National Gallery, London, No. 1842). In

this trial a very high resolution was used; the small fragment, measuring 29 by 41 square millimeters, was scanned in twenty individual images per filter, each 1,300 by 1,030 pixels in size, with an overlap between successive images of 100 pixels. At this imaging distance, the change in image scale between filters was less than 1 pixel, and it was not, therefore, necessary to resample the images onto the same scale. The corresponding images through different filters were aligned automatically using a cross-correlation routine in VIPs, an imaging software developed at the National Gallery (Cupitt and Martinez 1996). The twenty images for one reference channel were assembled into a mosaic automatically, and images for the other channels were then assembled using the same parameters. An enlarged detail from the bottom right of the final image (rendered to show the appearance of the fragment as if illuminated by day-



FIGURE 3 Detail from *Heads of Angels* (National Gallery, London, No. 1842) imaged with the NG CRISATEL system, showing the absence of color fringes at the edges of cracks.

light) is shown in figure 3. This demonstrates the accuracy of interchannel image registration, as no color fringes are seen at the edges of the cracks (a common problem with multiband images).

For each pixel in the final assembled image, the spectral reflectance was obtained through a cubic spline interpolation between the thirteen data points from 400 to 1,000 nm. This per-pixel spectral information allows the color of a painting to be simulated as it would appear under different illuminants. For the wall painting fragment examined here, the appearance was simulated under two widely different illuminants: daylight and candlelight. This was achieved by multiplying the spectrum of each pixel by the spectral power distribution of the chosen illuminant, with the results rendered using the 1931 2° CIE standard observer weighting functions (ASTM E 308) to give a color image of the painting under that particular illuminant (figs. 4a, b).

Pigment Identification

Visible spectrometry is not generally an efficient method of pigment identification. The surface color of an area often gives as much information as the spectra themselves, and simple visual inspection under high magnification can



(a)



(b)

FIGURE 4 Color images of *Heads of Angels* rendered under (a) daylight and (b) candlelight.

reveal particle size and shape—two characteristics that greatly assist pigment recognition. However, the addition of the three infrared channels to the new CRISATEL system may aid the identification of pigments by spectral reflectance, as the behavior of pigments in the near-infrared region is not necessarily evident in their color. For example, it is difficult to distinguish between indigo and Prussian blue using conventional microscopy (Berrie 1997; Scheppe 1997), but it is relatively easy to distinguish between the two from their near-infrared reflectance spectra. Comparing the NG CRISATEL system's reconstructed spectra for the Pébéo chart mentioned earlier with those measured with either of the two spectrophotometers (see fig. 2) shows that the new multispectral system is on the whole comparable to a spectrophotometer.

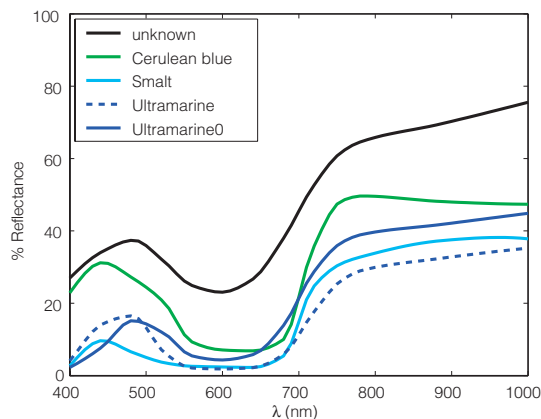

(a)

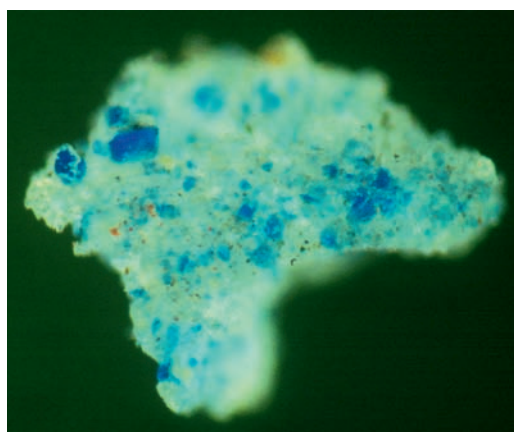

(b)

FIGURE 5 Identification of unknown blue pigment from *Heads of Angels*: (a) reflectance spectra of blue region compared with library spectra for ultramarine in linseed oil, ultramarine in egg tempera, smalt, and cerulean blue, showing the ultramarine samples to be the best matches; (b) photomicrograph under polarized visible light of blue pigment sampled from the same area of the wall painting.

The ability of the multispectral system to produce tentative pigment identifications was assessed on four regions of the *Heads of Angels* wall painting fragment. These regions were the blue robe of the angel on the left in figure 4, the red fabric of the robe of the angel in the middle, the purple robe of angel on the right, and the black background on the left. For each color, the final averaged spectra were obtained from two separate regions, each comprising around 5,000 pixels (3.5 by 3.5 mm²). These spectra were then compared with a spectral library of sixty-three historic artists' pigments to find the best match.

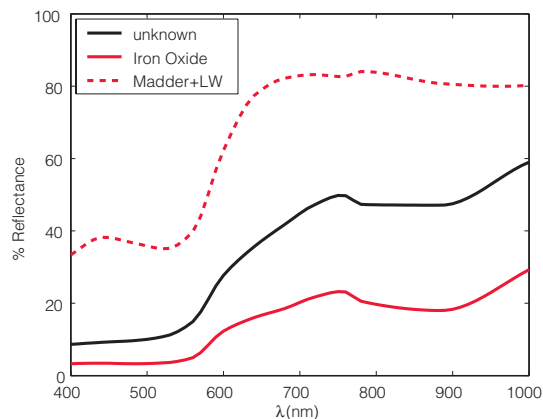

(a)

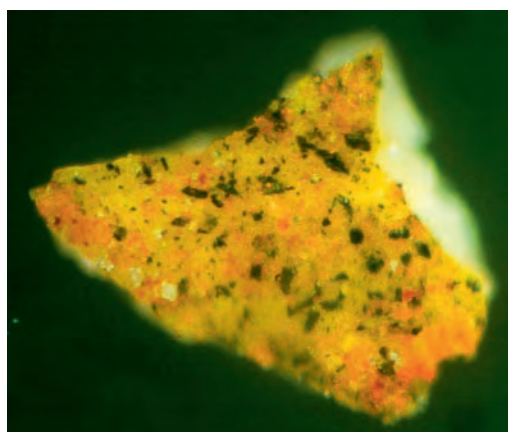

(b)

FIGURE 6 Identification of unknown red pigment from *Heads of Angels*: (a) reflectance spectra of red region compared with library spectra for iron oxide and madder lake (mixed with lead white), showing iron oxide to be the best match; (b) photomicrograph under polarized visible light of red pigment sampled from same area of the wall painting.

The NG CRISATEL spectrum for the blue pigment gave reasonable matches with spectra from two samples of ultramarine (one in linseed oil and the other in egg tempera), smalt, and cerulean blue, but the best matches are with the reflectance curves for ultramarine (fig. 5a). A small sample taken from this region and examined under the microscope (fig. 5b) shows the characteristic angular particles of natural ultramarine. From the spectra in figure 5a, it can be seen that the three infrared channels of the CRISATEL system are particularly useful in differentiating between cerulean blue and the other pigments.

The NG CRISATEL spectrum for the red pigment gives an extremely close match with a standard spectrum of an iron oxide earth pigment but a poor match with the spectrum of a red lake pigment (madder lake mixed with lead white) added for comparison (fig. 6a). A small sample taken from this region and examined under the microscope (fig. 6b) shows the characteristic particles of iron oxide.

The NG CRISATEL spectrum for the purple pigment was matched with the spectrum of iron oxide, but under the microscope it was clear that there is a red lake layer above the iron oxide layer. The spectral features of the iron oxide dominate, and the red lake is not identified using this method, demonstrating the current limitations of the technique.

It was not possible to identify the black pigment either spectrally or with optical microscopy. It was later identified as degraded tin using energy-dispersive XRF analysis.

Future Developments

We have shown that it is possible to produce high-resolution images with high color and spectral accuracy using the NG CRISATEL system with a simple off-the-shelf camera fitted with a set of interference filters. However, so far the system can be used only in a studio environment for imaging small easel paintings. While the large-format CRISATEL JumboScan is more portable than the NG CRISATEL system, it is still not suitable for high-resolution in situ imaging of wall paintings (e.g., ceilings). Currently, imaging such paintings at high resolution requires either scaffolding or a heavy and cumbersome mechanical structure to lift the camera to the upper parts of a wall or ceiling.

A portable multispectral system for remote imaging of wall paintings is currently under development. The prototype remote imaging system consists of a camera and filters similar to those used for the CRISATEL systems but mounted on a small telescope. For quick color images, a simple RGB camera can be substituted. The use of a telescope eliminates the need for scaffolding or a lifting mechanism.

The prototype is designed to have a resolution of 5 pixels per millimeter when imaging a painting at a distance of 30 meters. The pointing direction of the telescope and the focus position of the camera are computer controlled and accurately recorded as the images are taken. This will make it possible to render the wall paintings in 3D. The camera system will be automatically controlled to scan, mosaic, and render the images in 3D by a small portable computer. Both the camera system and the computer stay at ground level

during operation. The system weighs approximately 20 kilograms and can be fitted into a suitcase. The portability of the system means that it can be taken to remote sites to image large paintings in situ from ground level. Details of the prototype portable remote multispectral imaging system and results from the first field tests have been reported (Haida Liang, Keita, and Vajzovic 2007).

Acknowledgments

We would like to thank Marika Spring for sampling the *Heads of Angels* wall painting fragment and providing photomicrographs.

Notes

- 1 VASARI stands for Visual Arts System for Archival and Retrieval of Images.
- 2 The term CRISATEL is derived from the full name of the project, Conservation Restoration Innovation Systems for Image Capture and Digital Archiving to Enhance Training Education and Lifelong Learning.
- 3 See www.pebeo.com.

References

- Berrie, B. H. 1997. Prussian blue. In *Artists' Pigments: A Handbook of Their History and Characteristics*, ed. E. W. FitzHugh, vol. 3, 191–217. Oxford and Washington, DC: Oxford University Press and National Gallery of Art.
- Burmester, A., J. Cupitt, H. Derrien, N. Dessipris, A. Hamber, K. Martinez, M. Müller, and D. Saunders. 1992. The examination of paintings by digital image analysis. In *3a Conferenza internazionale sulle prove non distruttive, metodi microanalitici e indagini ambientali per lo studio e la conservazione delle opere d'arte = 3rd International Conference on Non-Destructive Testing, Microanalytical Methods and Environment Evaluation for Study and Conservation of Works of Art*, ed. M. Marabelli and P. Santopadre, 199–214. Viterbo: Beta Gamma editrice.
- Cupitt, J., and K. Martinez. 1996. VIPS: An image processing system for large images. In *Very High Resolution and Quality Imaging: 31 January–2 February 1996, San Jose, California*, ed. V. R. Algazi, S. Ono, and A. G. Tescher, 19–28. SPIE Proceedings, vol. 2633. Bellingham, WA: SPIE: International Society for Optical Engineering.
- Haida Liang, K. Keita, and T. Vajzovic. 2007. PRISMS: A portable multispectral imaging system for remote in situ examination of wall paintings. In *O3A: Optics for Arts, Architecture, and Archaeology: 20–22 June 2007, Munich, Germany*, ed. R. Salimbeni,

- L. Pezzati, and C. Fotakis, vol. 6618, 661815-1-661815-8. SPIE Proceedings, vol. 6618. Bellingham, WA: SPIE.
- Haida Liang, D. Saunders, and J. Cupitt. 2005. A new multispectral imaging system for examining paintings. *Journal of Imaging Science and Technology* 49 (6): 551-62.
- International Commission on Illumination. 1978. *Recommendations on Uniform Color Spaces, Color-Difference Equations, Psychometric Color Terms = Recommandations sur les espaces chromatiques uniformes, les formules de différence de couleur, les termes psychométriques de la couleur = Empfehlungen für empfindungsgemäss gleichförmige Farbenräume-Farbabstandsformeln und zugehörige Begriffe*. CIE Publication, no. 15 (E-1.3.1) 1971/(TC-1.3). 1978 Suppl. no. 2. Paris: Bureau Central de la CIE.
- Lahanier, C., G. Alquié, P. Cotte, C. Christofides, C. de Deyne, R. Pillay, D. Saunders, and F. Schmitt. 2002. CRISATEL: High definition spectral digital imaging of paintings with simulation of varnish removal. In *13th Triennial Meeting, ICOM-CC, Rio de Janeiro, 22-27 September 2002: Preprints*, ed. R. Vontobel, 295-300. London: James & James.
- Luo, M. R., G. Cui, and B. Rigg. 2001. The development of the CIE 2000 colour-difference formula: CIEDE2000. *Color Research and Application* 26 (5): 340-50.
- Martinez, K., J. Cupitt, D. Saunders, and R. Pillay. 2002. Ten years of art imaging research. *Proceedings of the IEEE* 90 (1): 28-41.
- Ribés, A., H. Brettel, F. Schmitt, Haida Liang, J. Cupitt, and D. Saunders. 2003. Color and multispectral imaging with the CRISATEL multispectral system. In *The Final Program and Proceedings of the PICS Conference, the Digital Photography Conference: Processing Images, Image Quality, Capturing Images, Systems Conference: An Annual International Technical Conference on the Science and Systems of Digital Photography: Including the Fifth International Symposium on Multispectral Color Science: May 13-16, 2003, the Hyatt Regency Hotel, Rochester, New York*, 215-19. Rochester, NY: Society for Imaging Science and Technology.
- Saunders, D., and J. Cupitt. 1993. Image processing at the National Gallery: The VASARI Project. *National Gallery Technical Bulletin* 14 (1): 72-85.
- Schwepe, H. 1997. Indigo and woad. In *Artists' Pigments: A Handbook of Their History and Characteristics*, ed. E. W. FitzHugh, vol. 3, 81-107. Oxford and Washington, DC: Oxford University Press and National Gallery of Art.

Scientific Examination of the Traditional Materials and Techniques Used in Yuan Dynasty Wall Paintings

Rocco Mazzeo, Edith Joseph, Silvia Prati, Ma Tao, Gwénaelle Gautier, and Lucien M. van Valen

Abstract: *Few publications are available on the materials and techniques used by ancient Chinese artists to create Yuan dynasty wall paintings. Most of the information that is available appears in Chinese and is not well known by the international conservation community. This lack of knowledge may affect the interpretation and reliability of scientific examinations of Chinese heritage materials. This paper presents the initial findings from a study to compare the results of a literature survey on Yuan dynasty wall painting materials and techniques with the results of scientific examinations of samples collected from murals in a Yuan dynasty Daoist temple at Yao Wang Shan in Shaanxi province, China.*

The analytical techniques used to characterize the renders, preparation layer, and paint layers of the murals are optical microscopy, polarized light microscopy, scanning electron microscopy coupled with electron probe microanalysis, X-ray diffraction, Fourier transform infrared spectroscopy, Fourier transform infrared microscopy coupled with attenuated total reflectance spectroscopy, pyrolysis-gas chromatography-mass spectrometry, gas chromatography-mass spectrometry, differential thermal analysis, Raman microspectroscopy, and ion chromatography. The results obtained from the different analytical techniques used to characterize the Yao Wang Shan mural paintings are compiled in the Diagnostic Data Archiving System (DIDARS) database.

Few publications are available on the materials and techniques used by ancient Chinese artists to create Yuan dynasty (1271–1368) wall paintings. Most of the information that is available appears in Chinese and is not well known by the international conservation community. This lack of knowl-

edge may affect the interpretation and reliability of scientific examinations of Chinese heritage materials.

This paper presents the initial findings of a study to compare the results of a literature survey on Yuan dynasty wall painting materials and techniques with the results of scientific examinations of samples collected from murals in a Yuan dynasty Daoist temple at Yao Wang Shan (Medicine King Mountain)¹ in Shaanxi province, China.

Yuan Dynasty Murals in the Temple at Yao Wang Shan

The temple at Yao Wang Shan, built in 1272 C.E., during the reign of Zhi Yuan, contains one of the three or four remaining examples of a specific image of a Daoist painting from the Yuan dynasty. This image is called *chaoyuantu*, which can be translated as “Chart for Facing the Origin” or “Worshipping the Origin.”

Our research study was facilitated by the facts that the murals at Yao Wang Shan, unlike others with similar imagery,² are in their original locations and that apparently no restoration interventions had been carried out on them, except for an acrylic resin applied by one of the authors to preconsolidate some detached parts of the paint surface. This allowed scientific examinations to identify the original traditional materials and technique used.

Two murals, covering a total area of about 96 square meters, depicting the tour of the emperor and that of the queen are painted, respectively, on the east and west walls of Hanyuan Hall in the temple (fig. 1). The murals contain twelve groups of figures totaling eighty persons (emperor,

FIGURE 1 Tour of the Emperor mural on east wall of Hanyuan Hall in the Yao Wang Shan temple.



queen, high-ranking officials, concubines, and maid of honor). During the Cultural Revolution, the temple was used as a classroom, and windows were opened to let in sunlight, which destroyed part of the murals. Further damage was caused by small holes left in the walls by nails used to hang the children's school bags.

Literature Survey

Only four publications were found in our literature survey of the materials and techniques used by ancient Chinese artists to create Yuan dynasty wall paintings (Lu Hongnian 1956; Yu Feian, Silbergeld, and McNair 1988; Malenka and Price 1997; Chu Qi'en 2000).

The article by Lu Hongnian (1956) is one of the earliest publications on mural painting technique. He mentions that "in Yuan dynasty a new wet-wall painting technique was introduced using sand and clay mixed with glue for the wall, which was smoothed when still wet and painted before it was dry so that the pigments could seep into the material and become fairly safe from decomposition as long as the moisture level of the wall was under control."

Malenka and Price (1997) studied the materials and technique used to paint Yuan dynasty wall paintings that had been removed from a partially destroyed temple near Xinxiang (Henan province) and purchased in 1924 by the Philadelphia Museum of Art. Their research identified the use of clay, quartz, calcite, and fibers for the coarse render and a mixture of clay and quartz for the preparation

layer. They report that proteinaceous materials were detected in each of the layers, as well as traces of conifer resin in the fine white preparation layer.

Chu (2000), in his study of the murals in Yongle Palace (Shanxi province), refers to the use of sand, loess,³ hemp, sinew, and dried wheat straw for the coarse render and sieved loess and white paper pulp for the fine render. The prepared wall surface was then brushed with two layers of a mixture of bone glue and kaolin clay and allowed to dry before being painted.

Chu makes reference to Lu Di, one of the first generation of researchers in Dunhuang to study wall paintings, who writes that in the ancient wall paintings of the later period great attention was already paid to guard the surface against the alkalinization phenomenon that led to the production of a basic environment responsible for the crystallization of white salts on the surface. According to Chu, the origin of this problem was found to be the use of lime at the time the painting was created. If kaolin is used, this phenomenon does not occur. However, white salt crystallization can also appear if brick walls are the base of the wall painting, although this does not happen if the walls are made of dried mud bricks.

Chu notes that the murals in Minzhao Temple in southern Beijing are painted on walls made of dried mud bricks, and they do not show any alkalinization. He reports that, as was done for the Yongle Palace murals, the alkalinization phenomenon can be avoided, even in the presence of brick walls, by nailing a binding of hemp fibers to the wall surface

and then coating it with three layers of a mixture of sand, earth, and stove ashes.⁴

According to Yu (Yu Feian, Silbergeld, and McNair 1988), during the Yuan dynasty, the painting style changed and ink painting was practiced. However, Yu emphasizes that brightly colored painting was still very much in use. In his discussion of pigments, he describes the proper method for the use of malachite. He recommends using the best-quality malachite and washing, grinding, and then separating it into five grades. After this a clear solution of glue must be added. First-grade green malachite is too coarse, but all the other grades are useful. Yu based his views on those found in the manual of bamboo painting by Li Kan (2000) that dates to the Yuan dynasty.

Apart from Malenka and Price (1997) and Yu Feian, Silbergeld, and McNair (1988), the survey did not clarify the type of binding media used for pigment application. Some differences were found in the composition of the preparation layer; clay mixed with sand and kaolin are both mentioned. For the coarse render used to prepare the walls for painting, the survey showed the common use of clay, sand, and loess with the addition of vegetable fibers. The wet-wall (Lu Hongnian 1956) and dry-wall (Chu Qi'en 2000) painting techniques deserve further investigation.

Sample Analysis

Ten samples of the Yao Wang Shan temple wall paintings were submitted to a complement of analytical methods, which are summarized in table 1. Nine of the samples came from the east wall. Two of those samples, YW₁ and YW₁', were collected from the same location on the mural: YW₁ was used to determine the composition of the renders; YW₁', to evaluate the presence and concentration of soluble salt. Only one sample (YW₈) was taken from the west wall, to compare its composition with that of sample YW₆ from the east wall.

The samples were analyzed with the following techniques: optical microscopy (OM),⁵ polarized light microscopy (PLM), scanning electron microscopy (SEM) coupled with electron probe microanalysis (EPMA),⁶ X-ray diffraction (XRD),⁷ Fourier transform infrared spectroscopy (FTIR), Fourier transform infrared microscopy (μ FTIR) coupled with attenuated total reflectance spectroscopy (ATR),⁸ pyrolysis-gas chromatography-mass spectrometry (Py-GC-MS),⁹ gas chromatography-mass spectrometry (GC-MS),¹⁰ differential thermal analysis (DTA),¹¹ Raman microspectroscopy (μ Raman),¹² and ion chromatography (IC).¹³

Table 1 Mural Samples from Yao Wang Shan Temple

Sample	Color	Location	Analytical Method ^a
YW1	Grayish/white	East wall	OM, PLM, SEM/EPMA, DTA, XRD, IC
YW1'	Grayish/white	East wall	OM, SEM/EPMA
YW2	Green	East wall, near window	OM, SEM/EPMA, Py-GC-MS, GC-MS, μ FTIR/ATR, μ Raman
YW2'	Pale blue	East wall, near window	OM, SEM/EPMA, Py-GC-MS
YW3	Black	East wall, near window	OM, SEM/EPMA, Py-GC-MS, μ FTIR/ATR
YW4	Red	East wall, Emperor's robe	OM, SEM/EPMA, Py-GC-MS, GC-MS
YW5	White	East wall, Emperor's robe	OM, SEM/EPMA, Py-GC-MS
YW6	Blue	East wall, Emperor's robe	OM, SEM/EPMA, Py-GC-MS, μ FTIR/ATR
YW7	Salt efflorescence	East wall, lower part	IC
YW8	Blue	West wall, near window	OM, SEM/EPMA, Py-GC-MS, GC-MS, μ FTIR/ATR

^a Analytical methods:

SEM/EPMA = scanning electron microscopy coupled with electron probe microanalysis

OM = optical microscopy

PLM = polarized light microscopy

DTA = differential thermal analysis

XRD = X-ray diffraction

IC = ion chromatography

Py-GC-MS = pyrolysis gas chromatography-mass spectrometry

GC-MS = gas chromatography-mass spectrometry

μ FTIR/ATR = Fourier transform infrared microscopy coupled with attenuated total reflectance spectroscopy

μ Raman = Raman microspectroscopy

Results

Renders and Preparation Layer

Table 2 summarizes the analytical results for the renders and preparation layer. The Yao Wang Shan murals are painted over a wall made of compressed-earth bricks. A coarse render followed by a finer one was applied before the application of a white preparation layer over which the painting was executed. The presence in the coarse render of hemp fibers and bamboo slivers is clearly detectable by the naked eye, as well as under stereomicroscopy and cross-section observations.

PLM examination of sample YW1 showed the presence in the coarse render of sand, silt, and clay. This same composition was also found in the fine render, along with micritic, bioclastic crystalline limestone and shell fragments, together with *coccio pesto*,¹⁴ plagioclase, and quartz (fig. 2). XRD examination of the three main components of the renders (sand, silt, and clay) showed the presence of kaolinite and illite, together with a large amount of quartz, calcite, and plagioclase. Gypsum is also present.

IC analyses of sample YW1' determined the presence of a fairly large amount of soluble sulfates (3.73%) in the renders, with low concentrations of chloride (0.07%) and nitrate (0.66%). (The low amount of chloride is discussed below, in reference to the possible source of the green pigments.) The same IC results were obtained from the salt efflorescence collected from the surface of the east wall (sample YW7), although in this case the increased sulfate concentration (4.65%) can be associated with the deposition

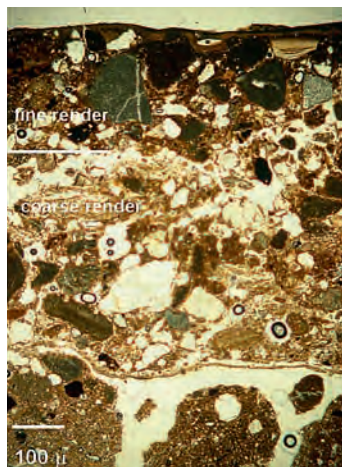

FIGURE 2 Thin section of sample YW1 viewed in transmitted light.

of wind-borne gypsum particles deposited on the surface of the mural.

SEM/EPMA analyses showed that the white preparation layer consists of a fine white clay (illite and kaolinite) with some quartz, feldspar, and needle-like gypsum (fig. 3), with increasing concentration toward the surface of the mural. The iso-oriented morphology of the preparation layer probably indicates that the surface was smoothed before painting.

Paint Layers

Table 3 summarizes the paint palette used for the Yao Wang Shan temple murals. Analysis of cross-sectioned samples

Table 2 Analytical Results for Renders and Preparation Layer of the Yao Wang Shan Temple Murals

Sample	Layer	Identified Compounds	Other Compounds	Identification Method ^a
YW1	Preparation	Illite, kaolinite, quartz, feldspar	Gypsum	PLM, XRD, IC, SEM/EPMA
	Fine render	Sand, silt, clay	Micritic and bioclastic crystalline limestone, shell fragments, <i>coccio pesto</i> , plagioclase, quartz	
	Coarse render	Sand, silt, clay	Hemp fibers, bamboo slivers, kaolinite, illite, quartz, calcite, plagioclase, gypsum, sulfates, chlorides, nitrates	
YW1'	Same as YW1	Sulfates, chlorides, nitrates		IC
YW7	Salt efflorescence	Sulfates, chlorides, nitrates		IC

^a Identification methods:

PLM = polarized light microscopy

XRD = X-ray diffraction

IC = ion chromatography

SEM/EPMA = scanning electron microscopy coupled with electron probe microanalysis

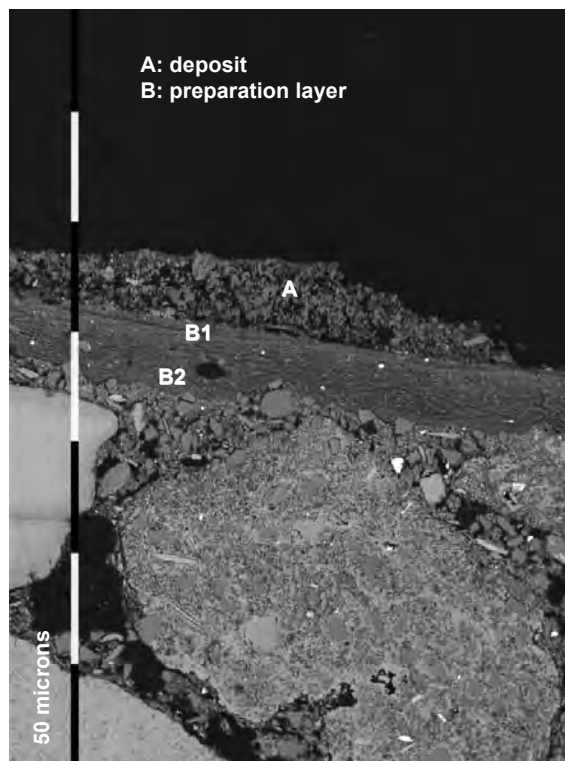

FIGURE 3 Results of SEM/EPMA analyses of the preparation layer in sample YW1.

	% Si	% Al	% Ca	% K	% S	% Fe	% Ti
A°	28.8	10.7	28.8	4.0	20.1	6.9	
B1*	17.2	12.9	38.0	5.19	25.3	1.24	
B2*	37.8	25.3	16.6	12.8	4.6	1.54	1.34

° Micritic limestone + fine needle-like gypsum

* Fine clay (illite-kaolinite) + quartz, feldspar + needle-like gypsum

Table 3 Paint Palette of Yao Wang Shan Temple Murals

Sample	Paint Color	Pigment Identification	Other Compounds	Identification Method ^a
YW2	green	atacamite	gypsum, whewellite, china clay, calcium nitrate, Paraloid B72, siccative oil, pine tree resin	SEM/EPMA, FTIR, μ FTIR/ATR, μ Raman, GC-MS, Py-GC-MS
YW2'	pale blue deep blue	lead white, azurite azurite, calcite, china clay	Paraloid B72, siccative oil, pine tree resin	SEM/EPMA, Py-GC-MS
YW3	black light green	ink lead white, atacamite, azurite	gypsum, whewellite, calcite, china clay, Paraloid B72, siccative oil, pine tree resin	SEM/EPMA, μ FTIR/ATR, Py-GC-MS, GC-MS
YW4	red orange red	vermilion red lead vermilion	Paraloid B72, siccative oil, pine tree resin	SEM/EPMA, Py-GC-MS, GC-MS
YW5	white	lead white	Paraloid B72	SEM/EPMA, Py-GC-MS
YW6	blue white blue	azurite china clay azurite	gypsum, whewellite, Paraloid B72	SEM/EPMA, μ FTIR/ATR, FTIR, Py-GC-MS
YW8	blue	azurite	gypsum, whewellite, china clay, oleic acid, pine tree resin	SEM/EPMA, μ FTIR/ATR, FTIR, Py-GC-MS, GC-MS

^a Analytical techniques:

SEM/EPMA = scanning electron microscopy coupled with electron probe microanalysis

FTIR = Fourier transform infrared spectroscopy

μ FTIR/ATR = Fourier transform infrared microscopy coupled with attenuated total reflectance spectroscopy

μ RAMAN = Raman microspectroscopy

GC-MS = gas chromatography-mass spectrometry

Py-GC-MS = pyrolysis gas chromatography-mass spectrometry

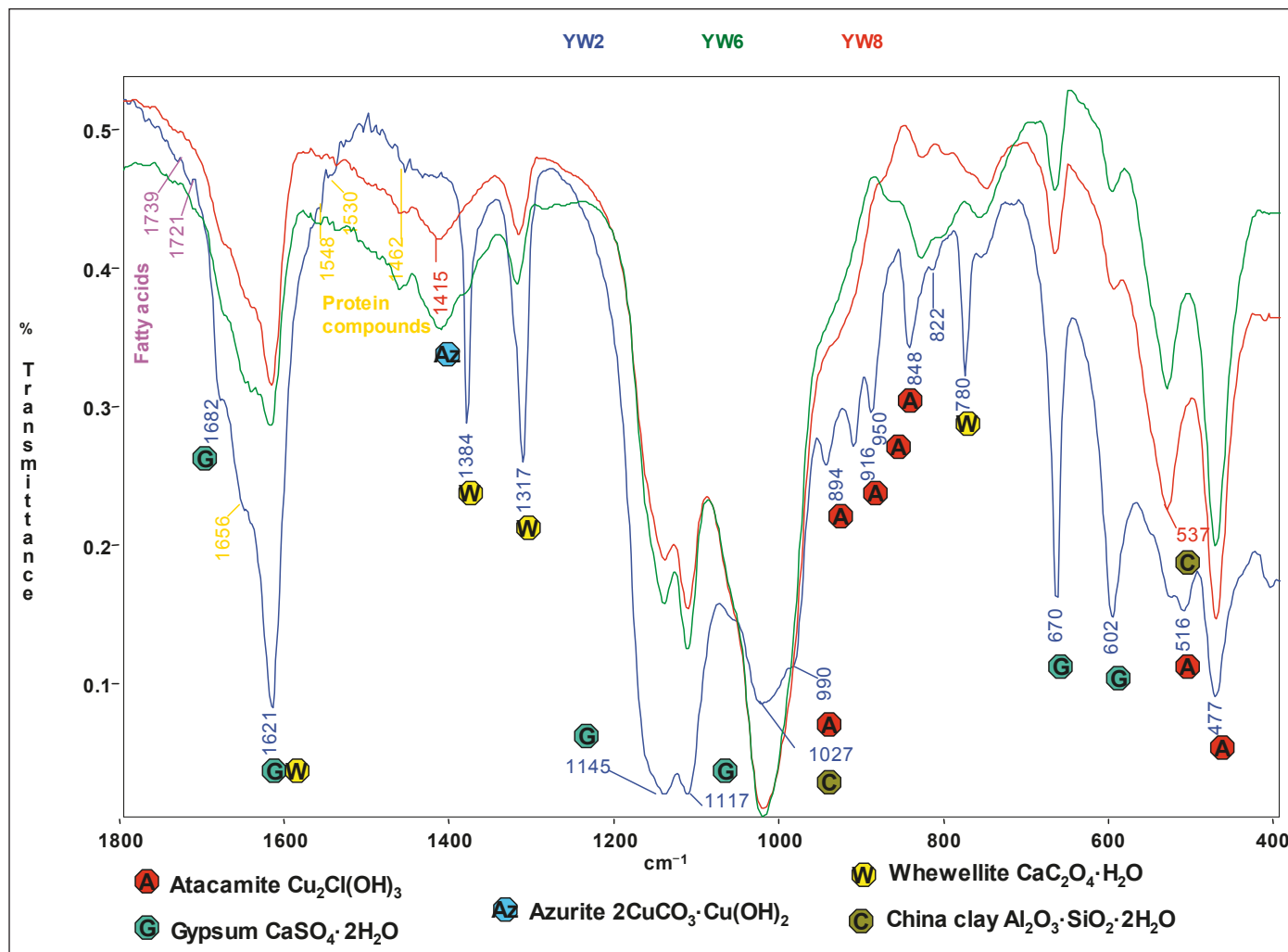

FIGURE 4 FTIR spectra at 2000–400 cm^{-1} for samples YW2, YW6, and YW8.

revealed that in some cases more than one paint layer was applied to achieve a given color tonality. For example, in sample YW4 an orange paint layer (red lead) was applied between two red paint layers (vermilion) to yield a warm tone; and in sample YW6 a white paint layer (white clay) was used between two blue paint layers (azurite) to achieve a lighter tone. Different tonalities were also achieved by mixing pigments, such as the pale blue tones that were obtained by mixing azurite with lead white (sample YW2'); for deeper tones, only azurite was used (sample YW8). Lead white was used to color white areas (sample YW5).

FTIR performed on bulk paint samples (YW2, YW6, YW8) identified the presence of other inorganic compounds,

such as gypsum, calcite, and whewellite (hydrated calcium oxalate, $\text{CaC}_2\text{O}_4 \cdot \text{H}_2\text{O}$) (fig. 4). This analysis confirmed the elemental composition of the samples obtained from the SEM/EPMA analysis. The FTIR spectrum of sample YW2 also showed weak bands at 1462, 1530, 1548, and 1656 cm^{-1} as well as at 1721 and 1739 cm^{-1} , and these bands are associated with the presence of proteinaceous and fatty acid materials.

Particular attention is directed to the green pigments of samples YW2 and YW3 (in sample YW3 the green color is found underneath a black layer of ink).¹⁵ Both paint samples are light colored when viewed in cross section, and they contain rounded green particles with an average diameter of 10 μm . Copper and chlorine are the main chemical constituents of the particles. EPMA analyses performed on a single particle revealed that the copper concentration decreases from the center outward, while the chlorine concentration increases (fig. 5). Both μRaman and $\mu\text{FTIR/ATR}$ analyses

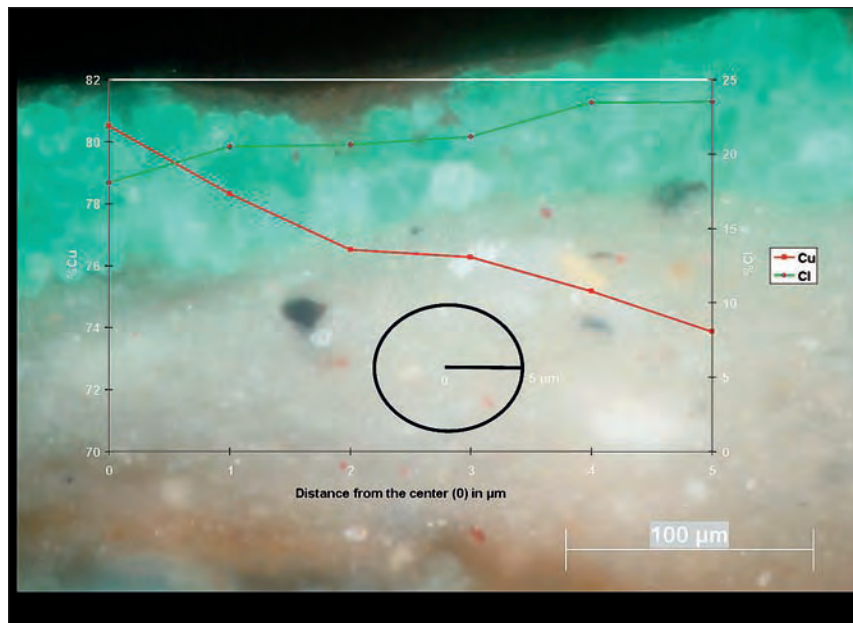

FIGURE 5 Cross-section photomicrograph (background) of rounded particles of green atacamite pigment in sample YW2. Superimposed is an EPMA-obtained profile of the copper and chlorine concentration distribution within a single particle.

performed directly on the cross-sectioned samples confirmed the green pigment is atacamite. Lead white was also detected mixed with atacamite and azurite in sample YW3, imparting an even lighter tonality.

Binding Media

In all samples, the Py-GC-MS analyses performed in both normal and derivatization conditions indicate the presence of Paraloid® B72, an ethyl methacrylate copolymer applied by Chinese conservators two years ago to partially preconsolidate the paint surface (fig. 6).

High concentrations of the dimethyl ester of azelaic acid (nonanedioic acid) that were detected are evidence of a siccative (drying) oil in samples YW2' and YW3. Although this acid is commonly found in old and therefore degraded siccative oils analyzed with Py-GC-MS in TMAH derivatization conditions, it is not possible to assign unambiguously the results to a specific siccative oil (Chiavari et al. 1993; Chiavari et al. 1995; Chiavari et al. 2002). In this case, however, the drying oil is most likely tung oil, obtained from the seeds of tung trees (*Aleurites fordii*, *A. cordata*, and *A. montana*) that are indigenous to the mountain regions of China. This assignment is further supported

by historical information and by consideration of the fact that neither scientific nor historical evidence exists for the use of another type of siccative oil, such as linseed oil, in ancient China (Mazzeo et al. 2004). In *Tiangong kaiwu* (Exploiting the Works of Nature), a book written by Song Yingxing in the seventeenth century, specific reference is made to the use of tung oil mixed with lime for caulking ships or lining the inside of a well. In addition, Qi (1986) makes specific reference to the use of tung oil, mixed with brick powder, lime, flour, and pig blood, as priming material for painting wooden architectural decorations in the Qing dynasty (1644–1911).

Py-GC-MS analyses identified a pine tree resin in samples YW2, YW2', YW3, and YW4 through its characteristic dehydroabiestic acid marker. Because both Py-GC-MS and GC-MS analyses were performed on bulk samples, it is not possible to clarify where in the samples the natural resin is located stratigraphically. Nevertheless, microscope

observation of cross-sectioned samples viewed under UV light showed the presence of a thin layer on top of the colors

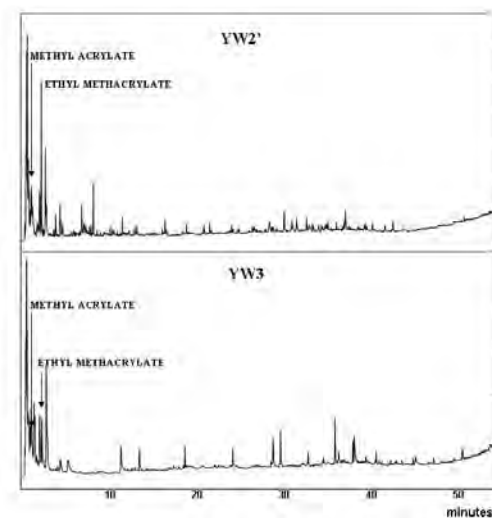

FIGURE 6 Py-GC-MS total ion chromatograms of samples YW2' and YW3, revealing the presence of ethyl methacrylate (Paraloid® B72) in normal conditions.

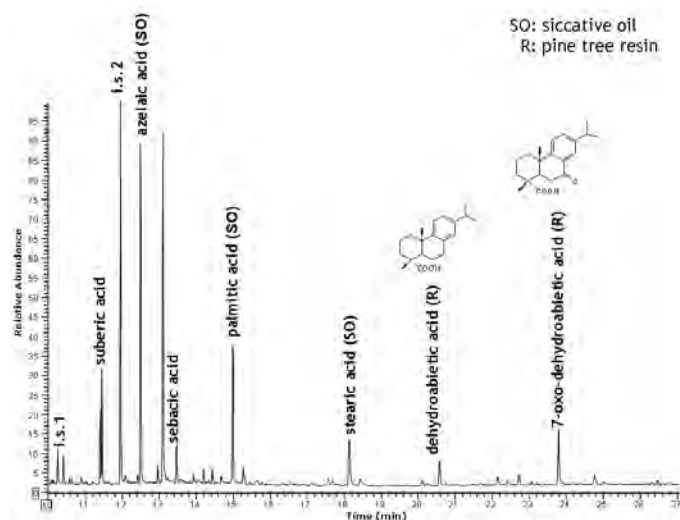

FIGURE 7 GC-MS total ion chromatograms of sample YW4. All acids are in the form of TMS esters.

that fluoresces orange-yellow and can be associated with the presence of a varnish.

In sample YW4, GC-MS analyses (Colombini et al. 2003; Colombini et al. 2004) were negative for protein, apart from a minor amount of glycine detected (0.3% w/w). In general, the gas chromatogram shows a different protein profile if compared with those commonly found in proteinaceous materials. Therefore, the presence of an animal glue used as a binding material can be excluded.

The presence of both a siccative oil (binding medium) and a pine tree resin (varnish) was confirmed through GC-MS analyses of samples YW2, YW4, and YW8 (fig. 7). Nevertheless, the palmitic/stearic acid ratio was not uniform in all samples, ranging from 0.8 (YW2) to 3.4 (YW4), with a very low azelaic acid content in sample YW8, where oleic acid and C15 and C17 fatty acids were also detected. Since the oleic acid is not a component of siccative oil, it may have an animal origin.

Further evidence that a siccative oil was used as a binding medium is found in sample YW4. Microscope observation of a cross section of this sample viewed under UV light shows that both the preparation layer and the red paint layer fluoresce yellow.

Results Database

The results obtained from the different analytical techniques used to characterize the Yao Wang Shan mural paintings

are compiled in the Diagnostic Data Archiving System (DIDARS) database. Sample pages from this database are shown in figure 8. The database was developed by one of the authors as part of a UNESCO-DPRK Funds in Trust project (Mazzeo 2005).¹⁶

The database is a useful archiving tool, especially for compiling results from many different analytical techniques, making it possible for researchers to share results online with participating laboratories. User-friendly, the database is accessible to a range of interested individuals, including conservation scientists, conservator-restorers, archaeologists, and art historians.

Discussion

The analytical results regarding the paint palette and original preparation technique of the Yao Wang Shan mural paintings are in good agreement with the literature survey results. Furthermore, the morphology of these murals is stratigraphically similar to that of other Yuan dynasty wall paintings exhibited in the Philadelphia Museum of Art (Malenka and Price 1997).

The fine white preparation layer was applied over the fine and coarse renders and then smoothed while still wet (Lu Hongnian 1956), a practice that is common to other far East Asian mural paintings (Mazzeo et al. 2004). There is no evidence that colors were applied while the preparation layer was still wet, as analysis of cross sections of samples from the paintings reveal the presence of a discontinuity between the two layers.

Even though the paint palette is restricted to a few colors, some paints were applied in multiple layers as well as in a mixture of pigments to lighten or deepen their tonality, such as for the blues in samples YW2' and YW6 and red in sample YW4. Analyses confirm the presence of a green pigment based on copper hydroxyl chloride compounds (Piqué 1992; Godfraind 2000). Because of the particular rounded shape of the pigment particles and the very low concentration of chlorine detected by IC in the renders, we favor a synthetic origin for this pigment rather than a natural alteration of malachite.

Three kinds of organic materials (siccative oil, conifer resin, and proteinaceous material) were detected in the murals, although their identification was complicated by the Paraloid® B72 that had been applied to the paintings during a previous conservation effort. The amount of proteinaceous material in the samples was very low compared with the



(a)

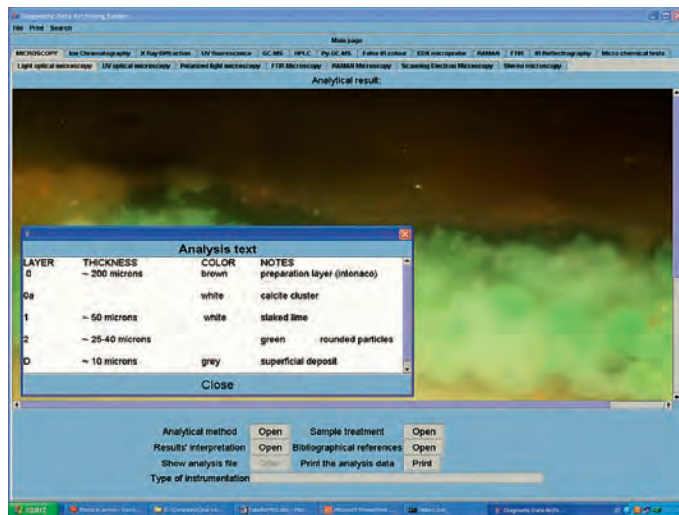

(b)

FIGURE 8 Sample pages from the DIDARS database showing (a) detail from the Yao Wang Shan mural paintings and (b) related sampling information.

amount of siccative oil (probably tung oil) detected. This suggests that an oil painting technique was used to create the murals rather than a tempera (glue) technique.

A pine tree resin appears to have been applied as a varnish on the wall paintings. The dark brown appearance of some parts of the murals (see fig. 1) where samples containing the natural resin were collected may be associated with degraded resin.

Conclusion

The literature survey has shown how important it is for conservation scientists to search for historical information when conducting scientific examinations of Chinese mural paintings. In the case of the Yao Wang Shan murals, the scientific results for the materials used to prepare the walls are in good agreement with the information collected through the literature survey.

On the other hand, except for what Yu (Yu Feian, Silbergeld, and McNair 1988) mentions about pigment, none of the surveyed Chinese publications make specific reference to binding materials or the use of varnish finishes. In particular, the finding of a siccative oil used as a binding medium in the Yao Wang murals is reported here for the first time. This finding points out the need to continue searching for more historical information to improve the interpretation and reliability of our understanding of the materials and techniques used in Yuan dynasty wall paintings.

Acknowledgments

The authors express their gratitude to the Shaanxi Cultural Relics Bureau in Xi'an, China, and the Xi'an Center for the Conservation and Restoration of Cultural Relics for providing samples of the Yao Wang Shan mural paintings. We also extend thanks to Pietro Baraldi, Department of Chemistry, University of Modena, for the Raman analyses; to Sonia Casolari, Department of Chemistry, University of Bologna, for the ion chromatography analyses; and to Sara Piombo, who worked on this project for her bachelor's degree thesis.

Notes

- 1 Yao Wang Shan was the home of Sun Simiao from about 581 to 682 C.E., during the Sui and Tang dynasties. Called the "King of Medicine," Sun Simiao is well known throughout China for his studies of acupuncture and herbal medicine.
- 2 Apart from the murals at Dunhuang and those at Yao Wang Shan, similar paintings have been removed from their original locations, with the resulting contamination of the original constituent painting materials. For example, the thirteenth-century Yongle Temple in Shanxi province had been completely rebuilt at a different location in 1959 to avoid being flooded during construction of irrigation works at the original site. Some of the iconography in the paintings of Yongle Temple are similar to the *chaoyuantu* in the Yao Wang temple. However, because of this relocation, the paint layers are no longer a

- reliable reference with which to study Yuan dynasty painting techniques.
- 3 The original Chinese word means “yellow ocher,” but it actually refers to the local loess, a buff to yellowish brown loamy deposit.
 - 4 In *Yingzao fashi* (1925), a book of architecture from the Song dynasty (960–1279), the use of clay (11.5%), white clay (11.5%), and sand (11.5%) mixed with macerated hemp (64%) and raw hemp (1.3%) is mentioned for the wall surface preparation.
 - 5 Samples were embedded in a resin support, then cross-sectioned and polished according to the conventional method. Dark field observation of cross-sectioned samples was performed using an optical microscope (Olympus BX51M). Photomicrographs were recorded with a scanning digital camera (Olympus DP70).
 - 6 A scanning electron microscope equipped with an energy dispersive X-ray analyzer (Philips XL 20 model SEM-EDX) was used on the same cross-sectioned samples already prepared for the optical microscopy observations. The elemental composition was determined using an acceleration voltage of 25–30 KeV, lifetime > 50 sec, CPS ≈ 2000, and working distance 34 mm. EDX-4 software equipped with a ZAF correction procedure for bulk specimens was used for semiquantitative analyses of the collected X-ray intensities.
 - 7 A Philips PV 1710 with a Cu-K radiation, 40 kV, and 40 mA, Ni filter radiation was used. Diffraction patterns were interpreted by comparison with data from the Joint Committee for Powder Diffraction Standards.
 - 8 FTIR analyses were performed on both bulk and cross-sectioned samples. The KBr pellet technique was used for bulk analyses, and spectra were recorded in transmission mode. Cross-sectioned sample analyses were performed by placing samples directly on the stage of a Thermo Nicolet Continuum FTIR microscope and analyzing each paint layer with the slide-on micro ATR (Si crystal) device in reflection mode.
 - 9 Analytical pyrolysis experiments were performed using an integrated system consisting of a CDS Pyroprobe 1000 heated filament pyrolyzer (Chemical Data System, Oxford, Pa., USA) and a Varian 3400 gas chromatograph coupled to a Saturn II ion-trap mass spectrometer (Varian Analytical Instruments, Walnut Creek, Calif., USA). A DB-5MS J&W capillary column (30 m × 0.25 mm i.d.; 0.25 μ film thickness) was programmed from 50°C to 300°C at 5°C min⁻¹, holding the initial temperature for 2 minutes. The samples, less than 1 mg, were pyrolyzed without treatment in duplicate through a quartz sample holder at 700°C for 10 seconds. The pyrolysis experiments were carried out in methylating conditions adding 5 μl of an aqueous solution of 25% of tetramethylammonium hydroxide (TMAH) to the sample before pyrolysis; in this way, methylation of carboxylic and hydroxyl groups was achieved. The Py-GC interface and the injection port were kept at 250°C. Injection mode was split (1:50 split ratio). The carrier gas was helium at a flow rate of 1.5 ml min⁻¹. Mass spectra (1 scan sec⁻¹) were recorded under electron impact at 70 eV from 40 to 450 m/z.
 - 10 A GC-MS system made up of a 5890 2A gas-chromatograph (Hewlett-Packard-USA) equipped with an on-column injection port and a quadrupole mass spectrometer detector (model 5971A) was used to separate and identify the organic compounds. Chromatographic separation was performed on a chemically bonded fused silica capillary column HP-5MS (i.d. 0.25 mm, length 30 m) with a 2 m deactivated silica precolumn. GC conditions for amino acids were as follows: initial temperature 100°C, 2 min isothermal, 6°C min⁻¹ up to 280°C, 15 min isothermal. Carrier gas: He, constant flow 1.2 ml min⁻¹. GC conditions for fatty acids, terpenic compounds, and nonsaponifiable fraction: initial temperature 80°C, 2 min isothermal, 10°C min⁻¹ up to 200°C, 6°C min⁻¹ up to 280°C, 8 min isothermal. Carrier gas: He, constant flow 1.3 ml min⁻¹. Samples (0.1–0.5 mg) were subjected to ammonia extraction and acid hydrolysis using microwaves. The acidic hydrolyzate was extracted with diethyl ether, and the extract was added to the residue from the ammonia extraction and, after drying, saponified and analyzed by GC-MS for the determination of terpenic species, fatty acids, and sterol content after derivatization with BSTFA (bis-(trimethylsilyl) trifluoroacetamide). The residual acidic hydrolyzate was analyzed by GC-MS after derivatization with MTBSTFA (N-(t-butyltrimethylsilyl)-N-methyltrifluoroacetamide). Quantitative amino acid analysis was performed by using the GC-MS in single ion monitoring (SIM) mode.
 - 11 A SETARAM TAG 24 apparatus was used with a heating speed of 20°C min⁻¹, under a CO₂ flux, and temperature range from 20°C to 1,000°C.
 - 12 Raman microspectroscopy of the paint samples was performed by placing the cross-sectioned samples on the microscope stage and directing the laser light through a 50x objective of an Olympus microscope onto the different paint layers visible under cross section. The Raman analyses were carried out with a micro-Raman Labram and a laser at 632.8 nm, at a power ranging from 0.5 to 5 mW (slit: 5 cm⁻¹), according to the sensitivity of the compounds to be investigated. A CCD (330 × 1,100 pixels) detector cooled by the Peltier effect at 200 K was used.
 - 13 A Dionex DX 100 was used with a conductivity detector.
 - 14 *Coccio pesto* is material consisting of crushed, dehydrated earthenware. It is obtained by pulverizing clay materials, such as bricks and roofing tiles, that are then baked at low temperature (900°C). The addition of *coccio pesto* to plasters confers waterproofing properties.
 - 15 Not enough sample was available to identify the composition of the ink.
 - 16 The project was titled “Preservation of Cultural Heritage in the Democratic People’s Republic of Korea, notably the Yaksuri Tomb and Capacity Building at the Korean Cultural Preservation Centre, DPRK.”

References

- Chiavari, G., D. Fabbri, R. Mazzeo, P. Bocchini, and G. C. Galletti. 1995. Pyrolysis gas chromatography–mass spectrometry of natural resins used for artistic objects. *Chromatographia* 41 (5–6): 273–81.
- Chiavari, G., G. C. Galletti, G. Lanterna, and R. Mazzeo. 1993. The potential of pyrolysis–gas chromatography/mass spectrometry in the recognition of ancient painting media. *Journal of Analytical and Applied Pyrolysis* 24 (3): 227–42.
- Chiavari, G., M. Ioele, S. Prati, and P. Santopadre. 2002. Py-GC-MS of the synthetic polymers used in past restorations on Giotto's mural paintings at the Scrovegni Chapel (Padova). *Chromatographia* 56 (11–12): 763–67.
- Chu Qi'en. 2000. *Zhongguo bi hua shi*. Beijing Shi: Beijing gong yi mei shu chu ban she.
- Colombini, M. P., A. Carmignani, F. Modugno, F. Frezzato, A. Olchini, H. Brecolouaki, V. Vassilopoulou, and P. Karkanias. 2004. Integrated analytical techniques for the study of ancient Greek polychromy. *Talanta* 63 (4): 839–48.
- Colombini, M. P., G. Giachi, F. Modugno, P. Pallecchi, and E. Ribecchini. 2003. The characterization of paints and waterproofing materials from the shipwrecks found at the archaeological site of the Etruscan and Roman harbour of Pisa (Italy). *Archaeometry* 45 (4): 659–74.
- Godfraind, S. 2000. Artificial copper chloride pigments: Methods of production and analysis. Postgraduate diploma diss., Courtauld Institute of Art, University of London.
- Li Jie. 1925. *Ying zao fa shi*. Shanghai: Shang wu yin shu guan.
- Li Kan. 2000. *Zhu pu xiang lu*. *Zhongguo shu hua quan shu*, no. 2. Shanghai Shi: Shanghai shu hua chu ban she.
- Lu Hongnian. 1956. [Notes on the methods of painting walls in China]. *Wen wu can kao zi liao = Journal of Museums and Relics* (8): 15–17.
- Malenka, S., and B. A. Price. 1997. A Chinese wall painting and a palace hall ceiling: Materials, technique, and conservation. In *Conservation of Ancient Sites on the Silk Road: Proceedings of an International Conference on the Conservation of Grotto Sites*, ed. N. Agnew, 127–38. Los Angeles: Getty Conservation Institute.
- Mazzeo, R. 2005. Analyses of painting technique. In *Preservation of the Koguryo Kingdom Tombs*, ed. S. Veg, 42. Paris: UNESCO. <http://whc.unesco.org/uploads/activities/documents/activity-275-1.pdf>.
- Mazzeo, R., P. Baraldi, R. Lujàn, and C. Fagnano. 2004. Characterization of mural painting pigments from the Thubchen Lakhang temple in Lo Manthang, Nepal. *Journal of Raman Spectroscopy* 35 (8–9): 678–85.
- Mazzeo, R., D. Cam, G. Chiavari, D. Fabbri, Ling He, and S. Prati. 2004. Analytical study of traditional decorative materials and techniques used in Ming dynasty wooden architecture: The case of the Drum Tower in Xi'an, P.R. of China. *Journal of Cultural Heritage* 5 (3): 273–83.
- Piqué, F. 1992. Scientific examination of the sculptural polychromy of cave 6, Yungang. M.S. thesis, University of London, Courtauld Institute of Art.
- Qi Yingtao. 1986. *Zhongguo gu dai jian zhu di bao hu yu wei xiu*. Di 1 ban ed. *Zhongguo gu dai jian zhu yan jiu cong shu*. Beijing: Wen wu chu ban she: Xin hua shu dian Beijing fa xing suo fa xing.
- Song Yingxing. 1980. *Tien-kung-kai-wu: Exploitation of the Work of Nature: Chinese Agriculture and Technology in the XVII Century*. Chinese Culture, no. 2–3. Taipei: China Academy.
- Yu Feian, J. Silbergeld, and A. McNair. 1988. *Chinese Painting Colors: Studies on Their Preparation and Application in Traditional and Modern Times*. Seattle: University of Washington Press; Hong Kong: Hong Kong University Press.

Documentation and Emergency Treatment of Wall Paintings in the Chamba Lakhang (Maitreya Temple): Developing a Methodology to Conserve Mural Paintings in India's Ladakh District

Sanjay Dhar

Abstract: India's Ladakh district is located in the Himalayan region of the state of Jammu and Kashmir. It is home to a large number of monasteries of various denominations of lamaistic Buddhism that have remained insular during the past two centuries for geopolitical reasons. Over the past two decades, as a result of growing interest in the region's artistic and cultural heritage, conservation efforts have been undertaken aimed at monuments of historic, religious, and cultural significance. However, not all these efforts have been conducted in a scientific manner. In the absence of a monitoring mechanism and clearly formulated norms and methodologies, it is difficult to regulate the quality of the interventions. Against this backdrop, the documentation and emergency treatment of wall paintings in the sixteenth-century Chamba Lakhang (also known as the Maitreya temple) in the village of Basgo, the first capital of the Namgyal dynasty, establishes a paradigm for future restoration projects in the region.

This paper details the documentation and emergency treatment of the wall paintings in the Chamba Lakhang and reports the manner in which local community participation and sustained efforts by individuals and organizations over the past six years ensured a multidisciplinary approach involving the architectural conservator, soil specialists, structural engineers, and paintings conservators. This approach builds a matrix for traditional conservation methodology and expertise through community participation and scientific conservation techniques. The heritage preservation model so developed complies with international guidelines and has as its ultimate aim the creation of local human resources for the preservation of the tangible and intangible heritage of the region.

Conservation and restoration of wall paintings is a difficult process, owing not only to the varied physical requirements of the building and its micro-environment but also to its social environment. This effort becomes more daunting in the context of developing countries. In India, for instance, with the sheer number of monuments of historic, religious, and cultural significance, the government is barely able to manage a small percentage of the most important sites; and few organizations in the nongovernmental (not-for-profit) and private sectors are equipped to deal with the totality of the complexities of conservation and restoration.

In large parts of India, as a result of overprotection and lack of communication between the authorities and the community, conservation is seen as antidevelopment. There is also the element of devotion and the desire to offer the best to the gods, which leads religious communities to take down damaged sections of structures and rebuild. This approach results from a lack of information about the potential of conservation. More often than not, help for many monuments never arrives due to uninformed authorities or a lack of funds and trained personnel. Add to this scenario a large number of untrained dilettantes, both national and international, working in developing countries, who manage to raise funds for some projects and then leave the sites in worse condition, creating suspicion and mistrust within the community and thus affecting future work in the area.

In 2000 the Namgyal Institute for Research in Ladakhi Art and Culture (NIRLAC) received funding for the documentation and condition assessment of the wall paintings in the Chamba Lakhang (also known as the Maitreya temple) at Basgo, a village located in the Ladakh district, also referred

to as Western Tibet, in the Himalayan region of the North Indian state of Jammu and Kashmir.¹ The Ladakh district is home to a large number of monasteries of various denominations of lamaistic Buddhism that have remained insular during the past two centuries for geopolitical reasons.²

The Chamba Lakhang project gained considerable attention when the Basgo Welfare Committee, the main forum for enabling various social, economic, and educational activities at the village level, raised funds to maintain and care for the monument. At the same time, the committee had an enlightened patron who was able to steer the community away from random reconstruction. Support from NIRLAC and other individuals resulted in the Basgo site being nominated to the World Monuments Watch List of 100 most endangered sites. It was against this backdrop that the project coordination team from NIRLAC, comprising the project coordinator, architectural and paintings consultants, and a member of the village committee, felt that the Chamba Lakhang at Basgo could be used to demonstrate the benefits of conservation in Ladakh and also to develop a benchmark for future projects in the area.

The village of Basgo is located about 35 kilometers west of Leh, the capital of Ladakh. Basgo was the first capital of the Namgyal dynasty, and today the site has the remains of the royal palace, the houses of ministers and nobles, and three temples dedicated to Maitreya located within the remains of the citadel walls, which were fortified with bastions, some of which survive. The largest of the extant historic structures at Basgo is the temple known as the Chamba Lakhang (*Chamba* is the Ladhaki word for Maitreya, the Future Buddha; *lakhang* means “prayer hall”), which was built in the sixteenth century by Tsewang Namgyal. The temple is located on a hill surrounded by a mountain on three sides; the present village of Basgo is located at its base. The main assembly hall of the temple measures approximately 9.6 by 9 meters and is 5.4 meters high. It is flanked on both sides by a stairwell and small rooms that are the residence of the lamas. Originally the temple had another floor over the main hall, but this was demolished during previous repairs, and now only the facade of the second floor survives. There is an additional floor enclosing the bust of Maitreya, with a small window through which he supposedly watches over Basgo, warding off evil and bringing good fortune to the villagers.

On entering the main hall of the temple, one is confronted by a colossal sculpture of Maitreya, but only the legs and part of the bust are visible from the entrance. As one

approaches and looks up, the entire sculpture can be seen. Maitreya is seated on a throne with hands in what is called the “turning the wheel of Dharma” position. On both sides of the pedestal on which Maitreya is seated are the life-size statues of the bodhisattvas Avalokitesvara Padmapani (holding a lotus) and Vajrapani (holding a thunderbolt).

Three walls in the main hall are covered with paintings. The hall has four slender painted pillars, and the ceiling, covered by wooden slats over horizontal support structures (purlins), is also painted with beautiful geometric and figurative designs.

The temple is owned by the Hemis Monastery (the Red Hat sect of Buddhism), which posts a lama who performs rituals and daily prayers at the temple and also looks after the ceremonial and spiritual needs of the villagers.

Chamba Lakhang Wall Paintings

The wall paintings at the Chamba Lakhang stand apart for their beauty and simplicity of execution. The colors, deep and rich against a light blue and green background, provide a profound experience for the viewer. The effect is that of entering a mandala (a Buddhist geometrical design meant for meditation) depicting the paradise of Maitreya and his accompanying deities. The artist has also achieved a distinctive style that marks the beginnings of the Ladakhi style in painting.

On the panel over the entrance is a depiction of the bodhisattva Vajrapani, and on either side are depicted deities known as the Four Heavenly Kings. Flanking Vajrapani on both sides are depictions of Tara, a Buddhist goddess traditionally shown in green and white forms.³

On the right-hand wall of the temple are three Dhyani Buddhas and Tsong-khapa (founder of the Gelugpa, or Yellow Hat, sect of Buddhism), and on the left-hand side is an image of one Dhyani Buddha and a Vajrapani. The other two panels, which depict Padma Karpo (an esteemed teacher of Vajrayana Buddhism) and Avalokitesvara, were repainted some sixty years ago. These are different stylistically from the rest of the paintings.

A register runs along the lower part of the wall painting, about 1.5 meters from the floor, that has scenes depicting the life of Buddha. In one part of the register there is a depiction of the Namgyal ruler who commissioned the temple, along with his family. The lines in the painting are delicate despite its large size. Though it appears to be rendered in panels, the

painting has a unified appearance that gives it a unique character. At the top of the walls there is a pattern of painted cloth that imitates the veil that covers the deity during the night to prevent the evil eye from falling on it.

Nature of the Damage to the Chamba Lakhang

The first time I entered the Chamba Lakhang, I was struck by the quality and intensity of colors. In most other painted chambers in Ladakh, the walls are completely covered with soot, and the paintings can barely be discerned. However, at the Chamba Lakhang, the intensity and the quality of paintings were clear, despite the major structural cracks through most of the panels. The figures in the paintings were also damaged from water seepage, and dried mud encrusted large portions. On closer examination, though the losses seemed limited, the delamination in the plaster, visible around the major cracks, was worrisome. Further, I was shown small fragments of painted plaster that had fallen to the ground. The main columns in the hall were out of plumb and had been supported with additional props; repairs to the roof around the areas of water seepage had damaged the plaster near the beam ends. Despite the damage, mostly of a mechanical nature, the walls appeared to be in good condition.

The present condition of the Chamba Lakhang is testimony to the people of Basgo, who over the years took prompt action to impede deterioration. In the recent past, the Basgo Welfare Committee undertook several measures to ensure that the conservation process would be systematic and scientific. It is a result of this informed approach that a significant part of the paintings have survived in their original condition.

Scientific Examination of the Chamba Lakhang

In order to develop an effective overall conservation strategy for the damaged wall paintings in the Chamba Lakhang, the following studies and tests were commissioned:

1. Detailed architectural drawings and condition assessment of the structure.
2. Geological survey of the stone and soil of the hill on which the temple is located.
3. Contour mapping of the surrounding area up to 100 meters, for a better understanding of water drainage in and around the site, as well as for developing the site map and future planning.
4. Detailed analysis of the mud and mortar samples used in the construction of the Chamba Lakhang and some of the structures in the citadel, specifically, the surviving bastion walls.
5. Detailed analysis of soil samples taken from the vicinity of the site and of the traditional building materials used in the region, to determine the best clay mixtures at the time of conservation.
6. Stratigraphic study of the paint layer and mud plaster.
7. Examination of the paint layer in ultraviolet light.
8. Microscopic analysis of surface patterns (brush-strokes, etc.) of the paint layer to understand the process of paint application and the artist's deliberate play with textures and effects and to determine the nature of deposits on the paint surface.
9. Study of cracks and crevices in the walls to ascertain insect and other biological activity, as well as the layering and deterioration within, using an auriscope (otoscope).
10. Establishment of safety parameters for the use of chemicals and solvents to clean the pictorial surface.
11. Analysis of the properties of the mud bricks used in the wall to determine water absorption rate, clay adhesion, and so on, for the purpose of developing the materials and methodology for conservation.
12. Correlation of the condition of the paintings with the architectural assessment of structural and building-related problems. This was done by superimposing the architectural assessment drawings over the graphic documentation of the wall paintings. This was important for developing a combined strategy for the conservation of the paintings and the structure of the temple.

Causes of Deterioration

The primary causes of deterioration of the paintings in the Chamba Lakhang are water, foundation shift, wind, and human activities.

Water

Most of the disfigurement of the painted surface was due to rainwater seepage. It is reported that this damage occurred over two days of continuous rain. Although the exact time is not clear, on the basis of oral accounts this must have hap-

pened at least 100 to 150 years ago. At that time the temple had been closed and left unattended, and the extent of the damage was only realized later, when it was opened. The damage was extensive, and two panels of the wall paintings were completely repainted. Today one can identify some of the surviving original paint layer in the repainted areas. The subject of this repainting is very different from what must have been there originally, as it is not in consonance with the original paintings. One of the repainted panels was again heavily damaged by water seepage; the exact time of this incident is also not clear (presumably about sixty years ago). It was obvious from our assessment that the roof over this wall had endemic problems that had been repaired several times, but the repairs seem to have always been insufficient.

As is well known, water is one of the strongest agents of deterioration, and mud-brick walls are particularly susceptible. Water moving down the walls during rains cuts into the plaster surface and washes away the water-soluble pigment. Also, water moving down the plaster surface leads to detachment between the various layers of the composite painting, creating areas of loss.

Foundation Shift

The Chamba Lakhang was built on the highest point of a hill, over soil composed of clay and mudstone. The underlying mudstone is extremely brittle and disintegrates into powder with little pressure. Until very recently, the temple's foundation rock was exposed and subjected to wind and snow erosion, which carved a furrow into the rock around the base. This furrow creates a micro-environment, trapping the passing wind and forcing it to circulate around the foundation. Loose particles of soil and sand act as abrasive, cutting into the foundation rock. As a result, portions under the temple walls have collapsed, causing shifts in the foundation, which then causes structural cracks in the walls. From local accounts, these cracks developed very early in the history of the temple. According to reports, no fresh cracks are developing, so it may be assumed that the building's foundation has achieved some sort of equilibrium.

Wind

It is unusual for wind to cause damage to paintings inside a closed structure. As an agent of deterioration inside the Chamba Lakhang, wind plays a subtle but important role. The walls of the temple are laid out in mud bricks, but the mortar is not spread sufficiently, leaving small gaps between the bricks. Due to structural movement, water seepage, frequent

repairs, and changes to the ancillary structure, the plaster on the exterior of the painted walls has disintegrated in most places. Though only one of the three walls with paintings is exposed directly to the elements, several openings in the adjoining structures (stairwell and residence rooms) allow wind to enter the hall. When its velocity is high, wind enters through the small spaces and crevices in the wall and into the main chamber of the temple through structural cracks. As it tries to escape through these cracks, the wind picks up sand particles freed from the mortar between the bricks in the wall, and these particles act as an abrasive, slowly cutting into the ground around the cracks and detaching small pieces of the paint layer along the edges of the cracks.

Human Activities

At the Chamba Lakhang, human activities have caused some damage to the wall paintings. For example, until recently, the devotees at the temple made offerings of ghee (clarified butter), which was poured into lamps that were kept burning all the time, depositing soot over the paintings. In recent years, however, the lamps have been lit in specially designed metal cupboards with a chimney and placed outside the main hall to prevent soot deposition on the paintings. Touching has also abraded the lower regions of the paintings.

Preserving the Chamba Lakhang Wall Paintings

As a proviso to the issues addressed in this paper, it is emphasized that the strict guidelines and processes generally followed in the execution of conservation projects in the West are often compromised in projects in the East, such as at the Chamba Lakhang, because of lack of funds, materials, trained personnel, scientific study, and awareness. In this project we have tried to overcome these problems, within the limited resources available, to develop a sustainable model for the region. The documentation and emergency treatment of the wall paintings in the Chamba Lakhang were planned as a model for future conservation efforts in Ladakh, taking into account the specific conservation needs based on an assessment of past practices in the region. The proposed model is based on international conservation practice and adheres to the various guidelines, charters, and projects that have been accepted as standards in the practice of conservation internationally. We used the opportunity to document the paintings, to undertake much-needed emergency measures, and to develop a treatment methodology after extensive testing of materials and techniques. Most important,

through a series of dialogues, on- and off-site, with all residents of Basgo, the concepts and problems of cleaning, reintegration of the pictorial surface, and ethics and norms of conservation were introduced to the local community.

Objectives for the Conservation Model

- To study the problems of deterioration of the wall paintings in the Chamba Lakhang.
- To record photographically the condition of the paintings to help in the proper assessment of the deterioration.
- To undertake basic experiments to understand the properties of materials used in the wall paintings.
- To undertake tests to establish the safety parameters of solvents for cleaning the paintings and to develop a safe methodology for cleaning the paint layer.
- To undertake emergency treatment in areas of potential loss.
- To explore local material resources and study logistical supply problems during the conservation process.
- To prepare cost estimates and a work schedule for conservation of the paintings in the Chamba Lakhang.
- To introduce the scientific concept of restoration to the local population and concerned authorities; to demonstrate what conservation entails through interaction with the local population while trying to understand their motivations and their expectations from the conservation process.

Anatomy of the Chamba Lakhang Wall Paintings

A detailed on-site study was carried out to fully understand the basic anatomy of the wall paintings and the technique used in their execution. The anatomy of the paintings is simple, as shown in figure 1:

- Wall: cast mud bricks in mud mortar.
- Ground: mud plaster mixed with vegetable fiber and grit and strengthened with a dilute animal glue solution.
- Priming (primer): kaolin mixed with animal glue.
- Paint layer: pigment mixed with animal glue. The paint layer comprises layers of various colors, which have been superimposed in some cases. The pigments that we were able to identify through analysis are yellow ocher, red ocher, lamp black,

orpiment, and cinnabar. Gold leaf has also been applied, and the figures have been outlined in black or deep red to give definition to the drawings.

- Protective coating: shellac was applied in selected areas, mainly over the reds and yellows in the garments. The purpose seems to have been to saturate the color and give a feeling of richness to the painted fabric rather than to serve solely as a protective layer. Tests to identify this varnish as shellac could not be carried out. Its identification is based on empirical observation and its use in the surviving Tibetan painting tradition.

Painting Technique

In art historical literature, the Chamba Lakhang paintings are considered second only to those found in Alchi, an eleventh-century temple group located some 40 kilometers from Basgo and containing the most significant extant examples of the painting style from Kashmir. The stylistics of Indian painting are defined by the art in the Ajanta caves in western India (second century B.C.E.–seventh century C.E.), which are the earliest known paintings in the country. Although a thousand years separate the paintings in the Ajanta caves and those in the Chamba Lakhang at Basgo, the painting technique has remained virtually unchanged. The paintings in the Chamba Lakhang signify the return of a style, fully evolved, that emerged from India, traveled the

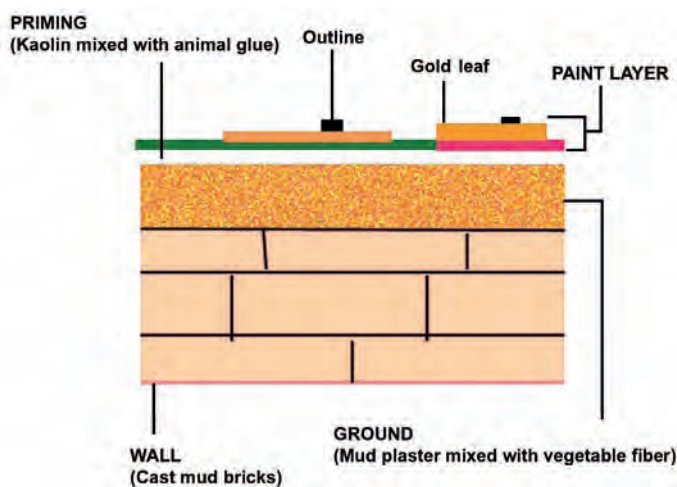

FIGURE 1 Schematic cross section showing the different layers making up the wall paintings in the Chamba Lakhang (Maitreya temple).

Silk Road, and gained from the artistic influences of other cultures, notably the Chinese in Tibet.

The painting technique used in the Chamba Lakhang conforms to the tenets of the seventh-century Indian canonical treatise on painting, the *Vishnudharmottara-Purana* (Shah 1958–61).⁴ Similar texts are also available in the Mahayana tradition, adapted from early Hindu texts, which provide the iconographic and iconometric details of the deities to be painted, details about the painting technique, and instructions on how to prepare the painting materials.

Preparation. The walls of the Chamba Lakhang are of cast mud bricks carefully prepared for application of the ground. The ground comprises clay, properly modified with an additive of pounded vegetable fiber and sand. After this had partially dried, the surface was burnished. Some water may have been used at this stage, as a slight change in the texture of the clay can be seen. Initially, we assumed that this might be due to the application of a separate layer of fine mud plaster. But stratigraphic studies show that the smooth finish seems most likely to be a result of working the surface with a metallic object. At this stage, a dilute hot solution of animal glue in water was applied to the surface by throwing the solution at the prepared wall from a container kept warm on a coal stove (this practice is still in use). After the surface was bone dry, a layer of white kaolin primer, from locally available sources, mixed with animal glue was applied. This formed the surface on which the painting was executed.

Preparatory Drawings. It could not be clearly established if the preparatory drawings were made using rubbings from cartoons. However, it does seem that the drawings may have been done directly on the wall after laying a grid with a snap cord. Although there is no clear indication of this process for transferring a drawing to the wall surface, this technique becomes apparent with observation of the levels of the various features of the wall painting. For example, the pedestal base of all the figures is on the same level, as is the *urna* (mark on the forehead of Buddha).

Painting. After the preparatory drawings were executed on the wall, they were filled in with light colors similar to those seen in the incomplete paintings on the walls flanking the Maitreya statue. Gold leaf was used to fill in areas representing flesh. Also, gold powder mixed with animal glue was used to paint ornaments. The resulting effect is uplifting. As light falls on the different figures in the wall paintings at different times of the day, the figures seem to come to life.

To better understand the materials and technique used in the Chamba Lakhang wall paintings, systematic scien-

tific analysis will be required. Some literature is available on the subject, but more information is required to fully appreciate and understand these paintings from a technical standpoint.

Condition Assessment of the Chamba Lakhang Wall Paintings

Before devising the documentation strategy for the wall paintings in the Chamba Lakhang, it was necessary to develop a uniform standard for recording the condition of the paintings within the broader parameters of the problems of deterioration in the wall paintings of the Ladakh region. To achieve this, we carefully conducted a brief survey of paintings of different representative periods and sites in the region to develop a standard condition assessment legend.

Another important consideration was that trained conservators would not always be available in the future for documentation on other conservation sites. Therefore, we trained para-conservators (locals with some art or science background hired for short durations) specifically for the purpose of documentation.⁵ For this group, it was imperative to keep definitions simple for recording the condition of the wall paintings without compromising the quality of the documentation. Therefore, distinctions were made on the basis of existing condition (as visible), not on the cause of deterioration, which would be assessed separately by the lead conservator and added to the report, along with results from scientific examination of materials and technique, and so on. In this way we formulated the condition assessment methodology.

In order to have access to all painted areas, we acquired a trolley of the cuploc type (a multipurpose scaffold system that allows easy assembly in tight spaces). This was important because pillars obstructed the movement of the trolley, and it had to be disassembled and then reassembled around the obstruction several times.

Before we started the condition assessment, detailed photographic documentation was carried out to record the condition of the wall paintings and various problems. Since the village of Basgo does not have electricity during the day, the interior of the temple was illuminated with solar lanterns (portable lighting devices that use a photovoltaic panel to convert sunlight to electricity and charge the battery). A small generator was also employed for additional illumination and for photography.

An initial survey of the wall paintings was conducted to identify typical problems. The parameters defining the

paintings' condition were also established. For two days, the assessment team familiarized itself with individual problems and their identification before beginning the documentation.

For purposes of graphic documentation, the walls were divided into arbitrary panels according to their composition, with care taken to avoid overlaps and dividing the figures. These panels were then measured and named. The important points in a figure were measured relative to the ceiling, as the floor was uneven, and plotted on a graph. Subsequently, line drawings were prepared. The condition of the wall paintings was recorded by laying transparent sheets over the line drawings and noting the relative position of the problems on them. The condition assessment criteria and format were adapted from the Getty Conservation Institute's project for the conservation of the tomb of Nefertari in Egypt. I have used the methodology developed for this project for my work in Ladakh and other places (see Cather 1991; Corzo and Afshar 1993).

After a detailed survey of the deterioration problems in the Chamba Lakhang, the condition of the painting was broadly categorized as follows:

- *Delamination.* This refers to separation of various layers within the composite structure of the wall surface. Two main types of delamination were recognized: (a) coarse plaster separation from wall (separation between the wall surface and coarse plaster) and (b) fine plaster separation from coarse plaster (separation of paint layer with primer from coarse plaster, as well as separation within the coarse plaster itself).
- *Cracks.* The cracks were divided according to their position and nature. A textile micrometer was used to broadly differentiate between minor cracks and fine cracks. Four main crack types were identified: (1) structural cracks (cracks caused by structural changes and extending down to the wall); (2) major cracks (cracks extending through the coarse plaster); (3) minor cracks (cracks extending through the primer and whose width measured not more than 1.5 mm at the widest point); and (4) fine cracks (cracks extending through the surface coating and/or paint layer and whose width measured less than 0.5 mm).
- *Losses/alterations.* To define the various types and the nature of loss and alteration, the visible layer was used as a reference point. The main cause of

discoloration is water seepage, so any change in the hue of the original color differentiated from the rest was recognized as discoloration regardless of the specific cause and nature; for example, discoloration due to oxidation of pigments was not separately marked. Five main types of losses were identified: (1) wall visible (implying loss of ground and subsequent layers); (2) coarse plaster visible (implying loss of the top surface of ground and subsequent layers); (3) fine plaster visible (implying loss of primer and paint layer); (4) primer visible (implying loss of paint layer and/or protective coating); and (5) flaking (implying potential areas of paint loss).

- *Surface deposits/previous interventions.* This broad category describes any obscuration of the paint surface. It does not distinguish between that caused by a prior intervention and that caused by a foreign substance, for example, between repainting and soot. Seven types of surface obliteration were identified: (1) soot (deposits from burning incense and butter oil); (2) grime (deposits from sweat and oil due to human contact with paintings); (3) clay (clay and/or kaolin from the primer washed down from the upper portions of the wall painting and deposited on the paint surface in the lower parts); (4) dust and dirt (although a uniform coat of dust and dirt is present, only those areas where it completely obliterates the paint layer were noted); (5) repainting; (6) clay infills; and (7) cement infills.

Emergency Treatment of the Chamba Lakhang Wall Paintings

During my first visit to the site, I observed that plaster along the major structural cracks in the painted walls had fragmented due to mechanical stress, with fine cracks radiating into the adjoining plaster. Water seepage had removed the underlying plaster in some areas around these cracks, so that the paint layer and parts of the plaster were hanging precariously. Some of these undermined fragments had already fallen. Slightly larger pieces of plaster that survived the fall had been picked up by the caretaker for safekeeping.

We decided to take emergency measures to protect the paintings for a number of reasons. It was obvious that by the time funds could be raised for conservation and restoration, additional losses would have occurred. In addition,

there was road-widening activity in the vicinity, and tremors from blasting could increase the loss. Further, the temple monks use a yak-tail mop tied to a long stick for removing cobwebs and dust from the walls, and in some places this has resulted in damage to the paint layer. The monks have been asked to discontinue the practice, but sometimes devotees decide to clean the temple themselves and wipe away the flaking paint layer (it is not possible to monitor visitors and devotees at all times).

It was determined that future damage and loss would occur primarily around the areas adjoining the structural and major cracks, in particular, from important areas. For example, in one panel on the west side, the entire face of the Dhyani Buddha is lost. However, one small fragment on the upper edge of this loss defines the topmost position of the hair knot, thus giving a reference for the dimension of the face. The plaster adjoining the cracks, in particular, in areas that also had been affected by water seepage, was delaminated from the wall in most areas, posing a serious threat to its survival. Therefore, as part of the documentation and condition assessment of the wall paintings in the Chamba Lakhang, it was decided to seek additional funds to undertake emergency treatment.

Emergency treatment was designed with the following considerations:

- Intervention should be unobtrusive so that visitors and locals would not look at the treatment as defacing the images.
- Treatments should last without monitoring for a long period and without causing further damage or deterioration.
- Emergency intervention should not be taken as one of the processes of the actual later conservation.
- Integrity of the paint layer should be maintained by not introducing any material for consolidation or waterproofing, so as to allow the conservator a wider choice of techniques and materials at the time of the subsequent restoration.⁶
- Adhesive used for securing damaged areas should be reversible after a long period without affecting the paint layer.
- Adhesive should be soluble in a range of solvents to allow for maximum leeway in handling the paint layer later.
- Emergency intervention should be economical to carry out.
- Emergency intervention should be repeatable under a wide range of conditions typical to the region of Ladakh.
- Emergency treatment should be easy to carry out to allow for the possibility of using para-conservators.

Treatment Approach

Keeping in mind the above considerations, we fully explored the possibilities for securing the damaged areas. The chosen treatment was to secure the plaster pieces with synthetic fabric strips and also to consolidate major areas where the paint was flaking.

After testing different adhesives and facing materials, we decided against covering the entire damaged area with either long-fiber tissue paper or cloth, which would lead to problems during the intervening time and also during removal. It was also observed during tests that application of Paraloid® B72 for fixing the colors to allow for the use of a water-based adhesive, such as bone glue, substantially changed the tonal quality of the paint layer. The paint surface in many areas has a deliberate matte finish that would be affected by saturating it with a fixative. Thus any water-based adhesive and use of a fixative such as Paraloid® B72 had to be excluded.

After detailed tests, it was decided to secure the plaster and paint layer with strips of a fine-mesh synthetic cloth (monofilament stain-resistant polyester, 70 mesh) used for screen-printing. The mesh is resistant to chemicals and can be stretched across the cracks with ease, thus reducing slack. The fabric is nonhygroscopic, with a low thermal coefficient of expansion. This is important in the extreme climatic conditions of Ladakh. The use of a synthetic fabric was also dictated by the fact that it was primarily pieces of plaster that had to be secured in place, and paper or similar commonly used materials would not have been able to hold the weight of the plaster pieces if they were to fully detach.

Pidicryl® 126 was selected as the adhesive for securing the mesh strips to the damaged areas because it has properties similar to those of Plextol® B500 (methyl methacrylate/ethyl methacrylate copolymer),⁷ which has been extensively tested for such properties as reversibility and has been in use for a long time. The main feature of interest was that Pidicryl® 126 can be thickened with toluene to form a paste that does not percolate into the paint layer but forms a film on the surface when applied, which can be easily removed without causing any visible changes. Pidicryl® 126 thickened with toluene (7% by volume) was tested for

reversibility, penetration into the paint layer, alterations to the pigment, ease of application, strength, and load-bearing capacity in an area of plain plaster with damage similar to that on the painted area and also on mud bricks similar to those used in the walls.

Pidicryl® 126 also forms an emulsion with water that can be diluted to desired levels for greater penetration into the mud plaster. This emulsion, diluted to form a solution (5–8% in water), was used to consolidate the areas where the paint layer/ground had become powdery and to fix flaking paint.

Added advantages of the Pidicryl® 126 adhesive are its low peel strength (i.e., less force would be needed to peel off the mesh fabric at the time of removal) and high shear strength (i.e., more force is needed to pull the adhesive away from the wall). If pieces of plaster dislodge for some reason, they will be held in place and not fall.

Tests were carried out to check the reversibility of the emergency treatment. Toluene, acetone, isopropyl alcohol, and trichloroethylene were found suitable for removing the adhesive from the paint layer. The best results for removing the mesh strips from the wall, however, were obtained with trichloroethylene (TCE).⁸ This swelled the adhesive, allowing for the easy removal of the mesh fabric. Excess adhesive could be removed by light rubbing with the fingertips or by scraping with a scalpel without affecting the paint surface.

Treatment Application

The emergency treatment was carried out in 2000 as part of the condition assessment and documentation program. The mesh fabric was cut into strips approximately 1 centimeter wide to cover smaller fragments and approximately 2 centimeters wide for the larger fragments. The length of the strips was adjusted according to the size of the damaged area. One end of the strip was placed over the undamaged part of the paint layer on one side of the crack, and adhesive was applied over the fabric with a brush. This allowed a minimal quantity of adhesive to pass through the mesh cloth and onto the paint layer. After the adhesive dried, the mesh strip was extended to the opposite side of the crack, beyond the damaged area, and held slightly taut; then the other end was fixed likewise. The entire mesh strip was not pasted; selected points along its length were adhered to ensure that all the intermediate undermined plaster fragments were held to the mesh with the adhesive. If a fragment was small, about 2 to 4 square centimeters, it would need only one adhesion point; for larger fragments, about 6 square centimeters and greater, more adhesion points would be required. Thus a

single strip would cover about three or more fragments in a straight line. It is as if the crack has been “stitched” with the mesh strips (fig. 2).

This approach, along with the elasticity of the mesh strip, would prevent separation and fresh breakage of the plaster if there were any movement along the crack. In an extreme situation, if a plaster fragment were dislodged, it would still be held by at least one point (fig. 3). The adhesive is strong enough to hold some weight, but it will give way if there is increased pressure, thus preventing new damage. Furthermore, with this approach, in the event of any major movement in the building or an accident, the paint layer is likely to be stripped off the ground (*strappo*) and can be reattached later in extreme circumstances, thus minimizing the loss.

Pulverized areas and flaked paint were consolidated along structural and other major cracks before the mesh strips were applied. Pulverized ground was consolidated with Pidicryl® 126 diluted in water (5–8%). Small fragments along the edges of the cracks and larger parts of plaster were also consolidated with the same solution. This solution was also applied to fix flaking areas. In this case, drops of the adhesive were placed near the damaged area with a brush or



FIGURE 2 Section of the Chamba Lakhang's northeast wall, with a deep structural crack running down the center. The crack has been “stitched” with mesh strips (white patches) along its length.



FIGURE 3 Portion of treated painting with schematic detail showing the location of mesh strips (yellow outline) used to secure plaster on either side of the cracks (blue). Arrows indicate adhesion points and the direction of forces that hold fragmented plaster in place.

a syringe, and the solution would then get absorbed by capillary action. The flaking paint was settled by applying minimal pressure with fingertips over silicone paper.

In order to improve the penetration of the adhesive solution, alcohol was used as a surfactant; an added advantage was that it prevented water stains from developing. Further, since the relative humidity is very low in Ladakh, drying is accelerated, which also proved advantageous because it allows for repeated applications if needed in a shorter time span.

Over time, the mesh strips applied during the emergency treatment darkened slightly due to the deposition of soot and dust, making them invisible when viewed from a distance.

Discussion

The Chamba Lakhang project is part of a larger effort to develop the methodology for documentation and condition assessments of a large number of sites with wall paintings in the Ladakh district. The aim is to provisionally conserve this art with minimal cost while simultaneously ensuring the quality and longevity of the sites through minor interventions. Several issues need to be addressed:

- It is important to have an ongoing dialogue with the community where the wall paintings are located and the stakeholders to ensure that the decision-making process is transparent and consensual. Vital issues relating to practice and ethics in conservation, especially in the context of infilling, need to be explained in detail and strategies adopted to educate the people. This will ensure the survival of the site until it can be conserved properly.
- It is important for the international conservation community to study and develop emergency treatment options, as this may be the last chance for the survival of a large number of monuments in India and elsewhere.
- There is a need to develop standard testing and examination procedures that do not depend on the use of costly laboratory facilities, since more often than not these are neither accessible nor affordable in India and elsewhere. Also helpful is the development of a shared database of materials used for conservation in the West and their possible substitutes in countries such as India where there is no specific marketplace for conservation materials. This can be achieved through the active collaboration of international institutions.

Postscript

Work on the restoration and conservation of the wall paintings in the Chamba Lakhang commenced on April 10, 2004, three and a half years after the documentation and emergency treatment were carried out. A ceremony for the removal of the spirits from the images was conducted prior to commencement of work. The first phase of the project was completed by October 2004, during which the plaster and paint layer and areas of delamination were consolidated.

The final phase, involving cleaning and reintegration, will be carried out in 2006. A review of the emergency treatment showed that no fresh damage had occurred. In several areas, plaster fragments had dislodged from their surroundings, but they were held in place by the mesh strips, as intended.

Acknowledgments

Gratitude is extended to the people of the village of Basgo and to the Basgo Welfare Committee, who have over the years spearheaded the movement to restore the site of the Basgo citadel to its original glory in a sensitive and educated manner, much against the prevailing trend to bring down and rebuild culturally important structures in the Ladakh region. Thanks are also due to Jigmed Namgyal and Tara Sharma of the Namgyal Institute for Research in Ladakhi Art and Culture (NIRLAC) for the institutional support provided to the conservation movement in Basgo and to Martand Singh, chair of the INTACH (U.K) Trust, for providing financial support for the condition assessment and emergency treatment of the wall paintings in the Chamba Lakhang.

Notes

- 1 NIRLAC is a local nongovernmental organization established by the former royal family of Ladakh, with the objective of preservation of cultural heritage in the region. It has a wide range of activities, including documentation, listing, training, and assistance to local museums and village communities for maintenance of their collections.
- 2 Lamaism is the Mahayana Buddhism of Tibet and Mongolia headed by the Dalai Lama.
- 3 Interestingly, both images are painted in gold color and are identified on the basis of the iconography.
- 4 In the *Vishnudharmottara-Purana*, the chapter titled "Chitrasutra" elaborates on the technique and materials for painting. It gives detailed formulations for the preparation of the wall surface before painting, preparation of various types of brushes, colors, etc. It also provides the artist with instructions for visualization of the subject matter, as well as iconographic and iconometric details.
- 5 Most conservation projects in India rely on the use of skilled craftsmen, especially for the postconservation phase. The practice has not yielded positive results in terms of training these craftsmen, particularly for conservation purposes, since there is no attempt to retain them for other projects. In

view of this, I have trained a number of craftsmen and other individuals to handle basic conservation techniques for my projects, thus preparing a small number of conservation technicians who, for want of a better term, are referred to as *para-conservators*.

- 6 At the time of the documentation, there was a possibility that for reasons such as funding the actual conservation would be carried out by another team.
- 7 In India, polyvinyl alcohol emulsion and polyvinyl acetate (PVA) have been the adhesives of choice for the consolidation of wall paintings. The obvious shortcomings of these are fairly well understood, but they continue to be used in most conservation circles because many alternatives used in the West are not available in India. In 1997 I initiated a research project at the Indian National Trust for Art and Cultural Heritage to find suitable substitutes for some of these commonly used adhesives. One adhesive was Plextol®, for which the substitute identified was Picidryl® 126, a methyl methacrylate-based adhesive having an identical molecular structure, except for the difference in the additives, which could not be identified.
- 8 Trichloroethylene (TCE) is a hazardous chemical that mainly affects the central nervous system, causing headache, nausea, dizziness, clumsiness, drowsiness, and other effects similar to those of being drunk. TCE can also damage the facial nerves, and it can cause skin rash. Heavy exposure can damage the liver and kidneys. TCE causes cancer in animals and may cause cancer in humans. To minimize these risks when using TCE on-site, I used a fume extractor system consisting of a hood placed close to the area of application and a blower that directs air to the outlet. Further, used swabs were disposed of in a closed container, and proper ventilation of the chamber was ensured at all times.

References

- Cather, S., ed. 1991. *The Conservation of Wall Paintings: Proceedings of a Symposium Organized by the Courtauld Institute of Art and the Getty Conservation Institute, London, July 13–16, 1987*. Marina del Rey, CA: Getty Conservation Institute.
- Corzo, M. A., and M. Z. Afshar, eds. 1993. *Art and Eternity: The Nefertari Wall Painting Conservation Project, 1986–1992*. Santa Monica, CA: J. Paul Getty Trust.
- Shah, P., ed. 1958–61. *Puranas: Vishnudharmottara-Purana: Third Khanda*. Oriental Series, nos. 130 and 137. Baroda: Oriental Institute.

Surveying Paradise: The Conservation Survey of a Yuan Dynasty Wall Painting on a Clay Base

Kathleen M. Garland

Abstract: *When the Nelson-Atkins Museum of Art was built in 1933, a central gallery was designed specifically to display the Paradise of Tejaprabha Buddha and Attendants (ca. 1300–1324), a Yuan dynasty wall painting on clay, 7.13 meters wide by 14.83 meters high. The architectural atmosphere of a traditional Chinese temple was created for the gallery by adding a wood and clay-based gilded lacquer fifteenth-century temple ceiling. The space is enclosed by a set of seventeenth-century clay-based lacquer and wood gate panels. This paper focuses on the conservation survey undertaken on the Paradise of Tejaprabha Buddha wall painting. It describes the equipment and processes used for the survey and discusses the findings.*

The draft protocols from the Graphic Documentation Systems in Mural Painting Conservation Seminar (GraDoc), held in Rome in 1999, were used to establish the following goals for the survey: (1) document the condition of the art to monitor changes; (2) determine the conservation needs; (3) produce high-quality photography of the art for publication and scholarly research; and (4) conduct scientific analyses to record the use of historical materials and techniques, both for scholarly research and to assess the condition of the art.

Ultraviolet lights, a binocular microscope, a metal detector, and a digital boroscope were used to perform the condition assessment. Historical refurbishments done in China and the restoration history prior to and during installation are described. More than forty samples were taken to analyze the original materials, the Chinese refurbishments, and the more modern restorations. The results of the survey were recorded using Adobe Photoshop 7.0, which made it possible to demonstrate graphically both the deterioration and the physical history of the painting.

The Nelson-Atkins Museum of Art in Kansas City, Missouri, has one of the finest collections of Chinese art in the United States. In 2001 the museum, with a generous grant from the Getty Grant Program, conducted a conservation survey of one of the museum's most important works, the wall painting *Paradise of Tejaprabha Buddha and Attendants*, ca. 1300–1324 (fig. 1). For the opening of the museum in 1933, this work, along with two others,¹ was installed in a room constructed to provide the ambience of a Chinese temple—the most popular gallery in the museum. This paper focuses on the conservation survey undertaken on the *Paradise of Tejaprabha Buddha* wall painting.

History of the *Paradise of Tejaprabha Buddha* Wall Painting

The *Paradise of Tejaprabha Buddha* wall painting comes from the main hall in the lower monastery of the Temple of Expansive Victory at the Guangsheng Monastery in southern Shanxi province, China. This temple is an important Buddhist center with ties to the Yuan dynasty imperial court. The significance of the wall painting is considerable, since few such large Yuan dynasty murals exist intact or in situ and in relatively well-preserved condition.

The wall painting, executed on clay and measuring 7.13 meters by 14.83 meters (w × h), depicts the Tejaprabha Buddha, whose name means “blazing light,” surrounded by figures representing celestial bodies, including the sun, moon, and five planets of traditional Chinese astronomy. This painting was located on the wall of one of the gable ends of the hall; a similar painting on the opposite wall is now located at the Metropolitan Museum of Art in New York

FIGURE 1 Digital mosaic of the *Paradise of the Tejaprabha Buddha* wall painting.



City. Sometime before 1927, to pay for repairs to the building, the Guangsheng Monastery sold both wall paintings to the art dealer-scholar C. T. Loo, who was based in Paris (Anning Jing 1991). Other paintings believed to be from the same monastery can be seen at the University Museum, University of Pennsylvania, Philadelphia, and at the Cincinnati Art Museum, Ohio.

Removal and Reinstallation

The wall painting was removed from the temple sometime around 1930. Section lines where the painting was cut from the wall are still quite visible on the surface. It seems that the painting was pasted over with paper and possibly a peach gum (Anon. 2003),² then cut into small sections, roughly 40 square centimeters. These small sections were shipped to Paris and reassembled by C. T. Loo's restorers onto larger plaster of paris panels or blocks of varying sizes. The blocks were then shipped to Kansas City for installation in the Nelson-Atkins Museum of Art according to the recommendations from Rutherford Gettens and George Stout at the Fogg Museum at Harvard University, which seem to have been followed fairly closely (Nelson-Atkins Museum archives n.d.; Straus Center for Conservation n.d.; Stout and Gettens 1932).

The *Paradise of Tejaprabha Buddha* painting was installed on a wall at the museum in a specially designed gallery based on the architectural style of a traditional Chinese temple. This gallery was created using a wood and clay-based gilded lacquer fifteenth-century temple ceiling, acquired

from the Zinhua Temple in Beijing, and then enclosing the space with a set of seventeenth-century clay-based lacquer and wood gate panels donated by Loo.

The plaster blocks carrying sections of the painting were attached to the brick wall of the gallery with metal wire twists in each corner of the blocks (fig. 2). Holes were made through the front surface of the painting for these twists. Angle iron was used to support each plaster block from the

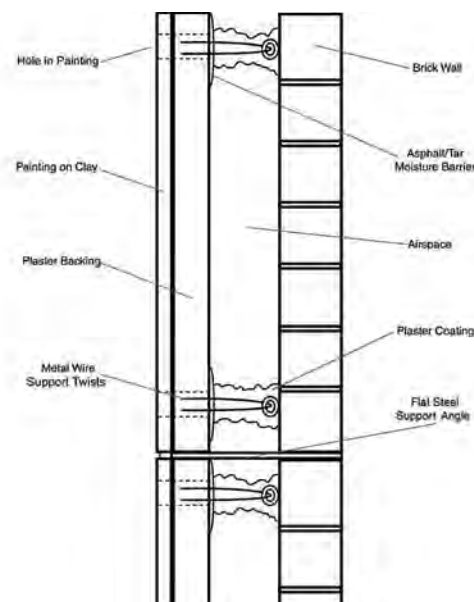

FIGURE 2 Schematic showing attachment of individual plaster blocks of the *Paradise of the Tejaprabha Buddha* wall painting.

bottom, and the wire twists were encased in plaster of paris at the back of the painting to make them rigid. A hard, unidentified filling material was used as a mortar in the 1-centimeter gap between all the plaster blocks. This mortar was given a wash of color to blend somewhat with the adjacent painting. When viewed from above, there is a gap of about 8 centimeters between the painting and the brick wall, but there is no direct access to the back of the painting. This prohibited any X-radiography. The left side of the painting may have been cut slightly to fit within the architectural space. No subsequent conservation intervention has been documented.



FIGURE 3 Physical setup for digital imaging of the wall painting.

Conservation Survey

The following goals for the conservation survey of the *Paradise of Tejaprabha Buddha* wall painting were established based on the draft protocols from the Graphic Documentation Systems in Mural Painting Conservation Seminar (Schmid 2000) held in Rome in 1999:

1. Document the condition of the art to monitor changes.
2. Determine the conservation needs.
3. Produce high-quality photography of the art for publication and scholarly research.
4. Conduct scientific analyses to record the use of historical materials and techniques, both for scholarly research and to assess the condition of the art.

The conservation survey was undertaken over a six-month period by two conservators from the Nelson-Atkins Museum and a contract graphic designer.³

Photography

In preparation for the condition assessment, the entire *Paradise of Tejaprabha Buddha* wall painting was photographed. The painting had not been sufficiently studied previously, in part because the gallery architecture and the size of the painting made photography very difficult. Consequently, no photographic record exists of any deterioration over time. However, new developments in digital photography now

make publication-quality documentation possible (Miller, Meluso, and Garland 2003).

Two photographers, one from the museum's photo department and the other a contractor, worked more than two months using a Mamiya RZ67 camera with a 50 mm lens with an Imacon FlexFrame 4040 digital camera back. Images (95 MB) were captured on a Macintosh PowerBook G4. A special setup was fabricated for the camera and two Broncolor Pico strobe lights, which were installed on special dollies to allow precise movement horizontally and vertically (fig. 3). Laser levels were used to align the camera to take eighty images covering the entire painting. Each area photographed also had a corresponding raking light image, which uses oblique illumination to cast shadows that reveal topographic features of the surface. A contract digital technician then took ten days to "stitch" the eighty digital images together using Adobe Photoshop 7.0 to achieve a complete photograph of the painting (see fig. 1). These high-quality images can be used to monitor the painting's condition over time, and the images can be easily shared with scholars around the world.

Long-term preservation of digital material has become an increasing concern because of obsolescence. All our digital files are stored on DVDs or CDs. There are at least three copies: one is kept in a Powerfile C200 jukebox in the photo department. This allows for easy access to the images while reducing damage to the discs. A spare copy is also kept with it. A third copy is kept in a fireproof safe in our off-site art

storage. A copy of any conservation-related documentation is kept in the conservation department.

Setup for the Condition Survey

An area adjacent to the wall painting was roped off so that visitors could observe the survey in progress. A notebook explaining various aspects of the survey proved very popular with visitors and staff. A scaffold tower was installed in the gallery for the conservators. Electric lifts and ladders were also available. The gallery was connected to the museum's computer network so that two laptops could be used by the team. Three mobile stations were set up, including a 30 GB computer with a slave drive, DVD-ROM, and large monitor on the ground station. Another station for a laptop was set up on the scaffolding.

Examination and Documentation

The *Paradise of Tejaprabha Buddha* wall painting was examined using a low-power binocular microscope to inspect the surface; a digital borescope to investigate behind the painting; and a metal detector to locate metal attachments. Ultraviolet illumination of the painting was helpful to distinguish overpaint. Archives at the Nelson-Atkins Museum and other institutions were also consulted for the history of the painting, including installation.

Documentation was done using Adobe Photoshop 7.0 on the images previously taken by the photo department. We chose to use this program because it is commonly available and unlikely to become obsolete in the near future, unlike most custom-made programs. Each of the eighty digital images, representing an area of about 127 square centimeters on the painting, was used to record information. The raking light image of each area was also included. Fifteen separate Photoshop layers were created and color coded to document different types of information: cracks, exposed ground layer, restoration, and so on (figs. 4–7). One layer was dedicated to written technical notes. The layers can be stitched into mosaics that can be studied individually or together, as in figure 7. The Photoshop zoom tool was especially useful, often allowing the conservator to conduct the examination of the painting on the screen, then check the painting on the scaffolding. The resulting electronic records are easy to store and search and can be used by scholars worldwide, unlike the paper or transparent plastic sheet documentation used in the past.

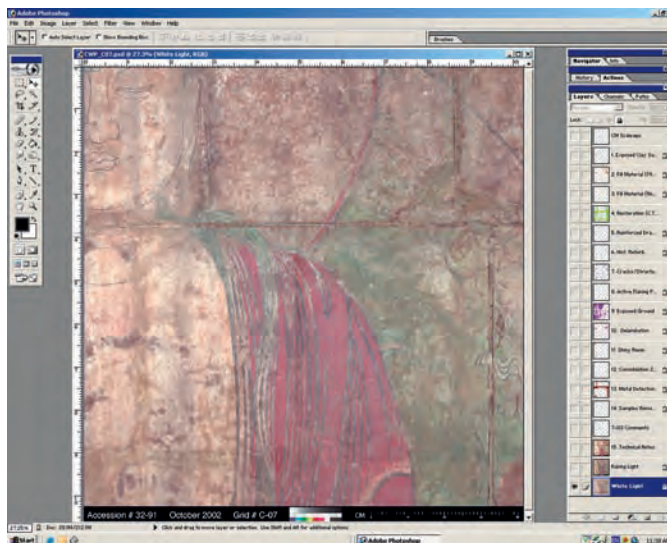

FIGURE 4 White-light survey layer as seen in Adobe Photoshop 7.0.

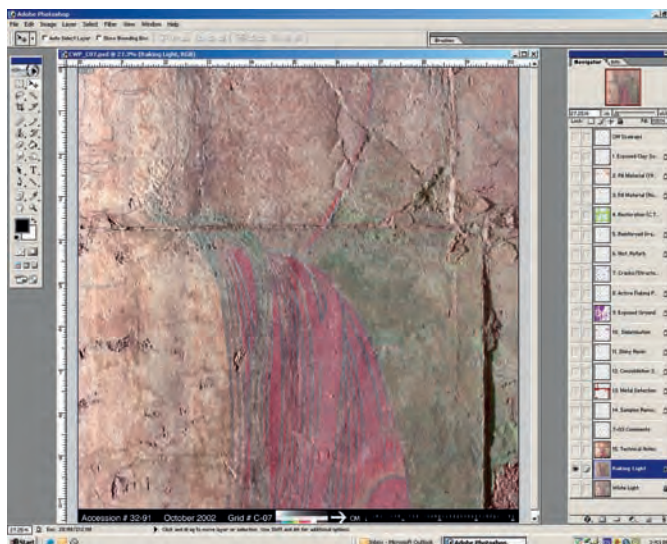

FIGURE 5 Raking light survey layer revealing topographic features of the wall painting.

Materials and Condition

John Twilley, an independent conservation scientist, analyzed some forty samples of the wall painting (Twilley 2003; Twilley and Garland 2003). Some of the findings from these analyses are described here.

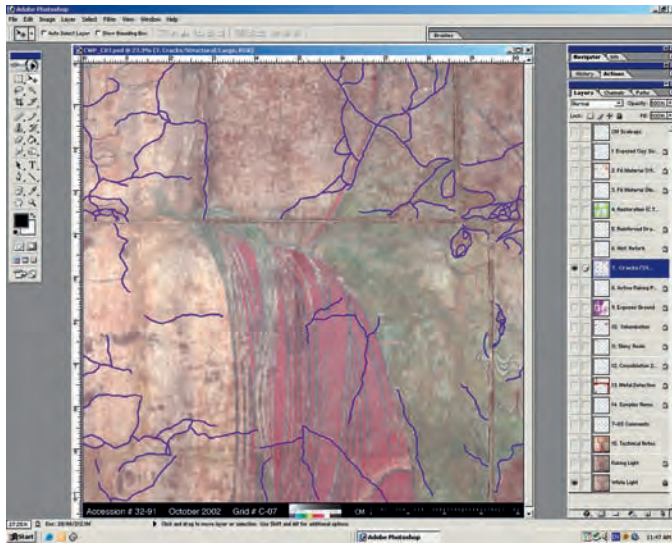

FIGURE 6 Survey layer revealing cracks.

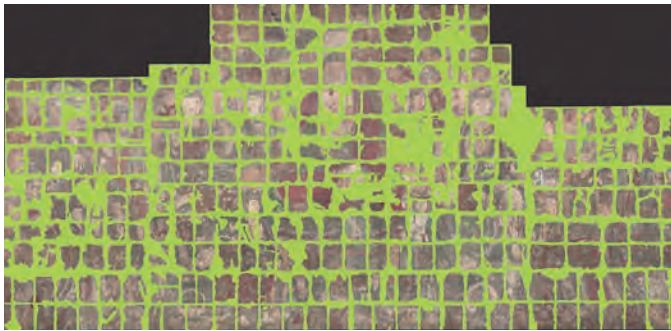

FIGURE 7 Assembled mosaic showing 1930s restoration.

Paint Layers and Pigments

The wall painting consists of a layer of tempera paint over a white ground, mostly kaolin. The paint medium could not be definitively identified, but it is likely to be water based. The original palette includes white kaolin clay, gypsum (white), lead white, azurite (blue), red lead, cinnabar (red), hematite (dark red), iron oxide (yellow), lamp black, charcoal, and atacamite (green). Dissolution and recrystallization have occurred in many of the original pigments, probably due to water ingress. Some pigments, such as the atacamite, red lead, lead white, and gypsum, have chemically interacted with the environment and possibly with each other, which may have affected their chromatic value.

One of the more interesting observations is the possibility that the green atacamite is actually man-made from corroded bronze, not from naturally occurring copper ores. Traces of tin oxide are visible as distinctive square prisms in scanning electron microscope images of samples from the painting. These tin oxide crystals are found only in the green pigments. Furthermore, the structure of the tin compounds did not show any cleavage or fracturing, as might be expected had they been present in minerals undergoing pulverization for pigments. Another interesting observation is the use of red lead, or minium, under the cinnabar, perhaps to enrich the colors or to extend the use of cinnabar.

Restorations

The 1930s restorations are generally found where the painting had been cut from the temple wall into small sections. These restorations can be seen in specular and raking light, as well as with ultraviolet radiation. The restorations are done in plaster of paris and tend to run over the cut lines by 3 to 6 centimeters (see fig. 7).

The colors used on these restorations, presumably applied by C. T. Loo's restorers, are quite easily distinguished from the original pigments. Brush spatters were added to blend the colors. Sometimes whole areas of one color adjacent to a cut line were overpainted. The pigments used by the restorers include viridian green, copper arsenate colors, green synthetic malachite, red lead with organic red lake, and white lead (Twilley 2003).

The survey indicated that about 10 to 15 percent of the painting has been overpainted, though most areas of exposed ground and clay have not been restored, giving the surface a pleasing aged appearance. No restoration was done where mortar fills the centimeter-thick gaps between the plaster blocks on which the painting sections had been reassembled. The mortar was only color washed to blend in, and the filled gaps are clearly visible.

Under magnification, the painted surface appears to have been "skinned" where the surface layer has been removed by overtreatment, probably by Loo's restorers. To compensate, many of the black lines have been "reinforced" with additional black paint, either during the Kansas City installation or by the earlier restorers. A coat of a clear shiny resin is also visible on all the black outlines on the feet, hands, and faces. The resin may have been added as a consolidant, but more likely it was used to saturate and enhance the black lines, since it is restricted to important

body parts. The material could not be identified, but correspondence in the museum's archives suggests that the resin might be Vinylite A,⁴ a poly(vinyl acetate) resin recommended by Rutherford Gettens as a consolidant (Nelson-Atkins Museum archives).

Structural Concerns

The *Paradise of Tejaprabha Buddha* wall painting retains only about 2 centimeters of the original clay backing, which is made from vegetable fibers and dried mud. The fragile nature of the unfired clay support and the paint layers was of considerable concern when the survey began. Also of concern was the 1930s mounting system for the painting: the large plaster blocks seemed insufficiently held by the wire twists at each corner and by the steel angle irons under each block. The hard mortar between the plaster blocks has fallen away in places, suggesting that vibration has occurred between the blocks. However, this vibration does not seem to have affected any original material.

Gentle tapping of the entire surface of the painting and examination of the crack patterns indicate that little damage has occurred to the original structure since installation. The paint, clay, and plaster layers are surprisingly well attached. The exceptions are the restored areas between the original cut sections of the painting and the circular areas where the original paint and clay ground have been cut to insert the wire twists. Most of these areas sound hollow when tapped, though they appear secure.

Conclusion

At the start of the survey, the museum's conservation department anticipated that the delicate material might need some emergency treatment. However, though very fragile, the painting is in good condition, and no treatment is required. Most important, there is now an excellent visual record should any damage occur in the future. The conservation team plans to examine the painting every two years using the digital records. If there is no change in four years, we will monitor less frequently.

Resources for the project included the following:

- two photographers for two months
- digital technician to "stitch" the image for ten days
- two conservators and a digital technician for six months
- consulting conservator for four days
- conservation scientist for ten days
- curatorial assistance for three weeks
- information technology backup for one week

Digital technology was critical for our project. For the first time a complete publication-quality image of the *Paradise of Tejaprabha Buddha* is available. The individual images of the painting provided a perfect opportunity to record the survey results in digital format. As others have noted, the use of digital records for surveys has both advantages and drawbacks (Schmid 2000). The equipment is expensive and challenging to use in nonmuseum settings. The software programs and equipment require a fairly steep learning curve. A full-time digital technician (our technician was not a photographer) familiar with Adobe Photoshop is an essential member of the conservation team. Additional information technology expertise was needed at times, and digital obsolescence is a serious concern. The layer setup for Photoshop makes printing a complete hard copy of the survey results very expensive and time-consuming.

The time required to conduct the survey was probably about the same whether done on paper or digitally. Nevertheless, the benefits of digital technology for this project far outweigh the disadvantages. The digital reports are extremely easy to share, copy, manipulate, and search, which is critical for our goals of long-term condition monitoring and scholarly research.

Acknowledgments

I wish to acknowledge financial assistance from the Getty Grant Program for supporting the survey and from the Kress Foundation for travel assistance. I also wish to acknowledge the assistance of Marc Wilson, Yang Xiaoneng, Lu Ling-en, and Jason Stueber, art historians; Joe Rogers, Steve Bonham, Elisabeth Batchelor, John Twilley, Jerry Podany, Zhang Zhiping, Eric Gordon, Dale Benson, Paul Benson, Christine Downie, and Cary Beattie Maguire, conservators and scientists; Lou Meluso, Jamison Miller, and Edward Robison, photographers; Tim Graves, Travis Morgan, and Kevin Dowd, information technology specialists; and Dinah Henderson, administrative assistant.

Notes

-
- 1 A fifteenth-century temple ceiling and seventeenth-century gate panels.

- 2 Polysaccharide exudates of *Prunus persica*. In 1955 Ru Anshi briefly described how peach gum was used in methods for detaching the Tang dynasty tomb paintings at Zhangjiawan, Xianyang, Shaanxi province, in 1952. Steps: cleaning the mud on the wall surface with water from top to bottom, drying the wall with coal fire, attaching fabrics to the painting with peach gums, detaching the painting with a thin-bladed knife from bottom to top, and sandwiching the painting with woodblocks for shipping (Anon. 2003 [trans. Ling-en Lu, assistant curator, Nelson-Atkins Museum of Art]).
- 3 A team of American and Chinese specialists were consultants on the project. They included Zhang Zhiping, director and senior engineer with the Conservation Center for Monuments and Sites, Beijing; Eric Gordon, paintings conservator, the Walters Art Gallery, Baltimore, Maryland; and Luo Zhewen, architectural expert on the Advisory Committee to the State Administration of Cultural Heritage, Beijing.
- 4 Vinylite is the former trademark name for poly(vinyl acetate) resins currently sold by Union Carbide under the trademarks AYAC, AYAB, AYAA, AYAF, and AYAT.

References

- Anning Jing. 1991. The Yuan Buddhist mural of the Paradise of Bhaisajyaguru. *Metropolitan Museum Journal* 26: 147–66.
- Anon. 2003. Ke zai chuli xing fanyin chu de dongtai baohu linian = [A dynamic concept of conservation as seen from the reinstallable wall painting]. *Zhongguo wen wu bao = Zhongguo wenwu bao* 9 (5).
- Miller, J., L. Meluso, and K. M. Garland. 2003. Digital imaging solutions for the reproduction and conservation documentation of a Yuan dynasty mural painting, *Tejaprabha Buddha and Attendants* (c. 1300), at the Nelson-Atkins Museum of Art. In *CIDOC/ADIT- 2003: Electronic Museum in a Modern Society: Challenges and Contradictions, September 1–5, St. Petersburg, Russia*, the International Committee for Documentation of the International Council of Museums (ICOM-CIDOC), and ADIT: Automation Directions in Museums and Information Technologies. <http://cidoc.mediahost.org/content/archive/cidoc2003/english/paper8cff.html?nomer=71>.
- Schmid, W., ed. 2000. *GraDoc: Graphic Documentation Systems in Mural Painting Conservation: Research Seminar, Rome, 16–20 November 1999*. Rome: ICCROM.
- Stout, G. L., and R. J. Gettens. 1932. Transport des fresques orientales sur de nouveaux supports. *Museion: Bulletin de l'Office international des musées* 17–18: 107–12.
- Twilley, J. 2003. Painting materials and deterioration phenomena in the Yuan dynasty wall painting from the Guangsheng Si Lower Monastery, Nelson-Atkins Museum of Art. Unpublished Report. Nelson-Atkins Museum of Art, Conservation Department.
- Twilley, J., and K. M. Garland. 2005. Painting materials and deterioration phenomena in a Yuan dynasty wall painting. In *Scientific Research on the Pictorial Arts of Asia: Proceedings of the Second Forbes Symposium at the Freer Gallery of Art*, ed. P. Jett, J. F. Winter, and B. McCarthy, 109–19. London: Archetype.

Determining the Internal Condition of the Leshan Buddha Statue

Zhong Shihang and Huang Kezhong

Abstract: For the purpose of conserving the Leshan Buddha statue, a thorough examination of the present condition of the stone core was carried out using several geophysical methods. This paper reports the main findings of our work regarding the cracks on the face of the Buddha and the thickness of the external shell.

The Leshan Buddha (Maitreya) statue is located at the confluence of the Min, Dadu, and Qingyi Rivers in southern Sichuan province, near the city of Leshan. Measuring 62 meters in height, it is the largest stone Buddha statue in the world. It was carved out of a cliff face during the Tang dynasty (618–907 C.E.), starting in 713 and ending ninety years later. The whole statue, including the face, hands, legs, and feet, was covered originally by a shell consisting of a lime and clay mixture. The eyes, mouth, eyebrows, hands, feet, and robe folds are painted (fig. 1).

Conservation work was done on the Leshan Buddha several times in the past. The latest, large-scale work was carried out in the 1930s and 1950s with the then-available techniques. In order to undertake thorough conservation and to obtain complete information on the statue's current state of preservation, we examined the stone core underneath the external shell using geophysical techniques (Zhong Shihang 2002).

Investigation

Stereoscopic photographs of the statue were first taken so as to document the present condition. Next, contour line maps were created focusing on the statue's front, two sides, and top (fig. 2). These maps were also used to locate test points on

the statue. Then geophysical techniques, including electrical resistivity, acoustic methods, and a neutron probe (Zhong Shihang 2002), were used for the following purposes:

- to determine the thickness of the external shell covering the stone core, so as to virtually reconstruct the form of the internal stone core;
- to detect deterioration points on the stone core;



FIGURE 1 The Leshan Buddha.

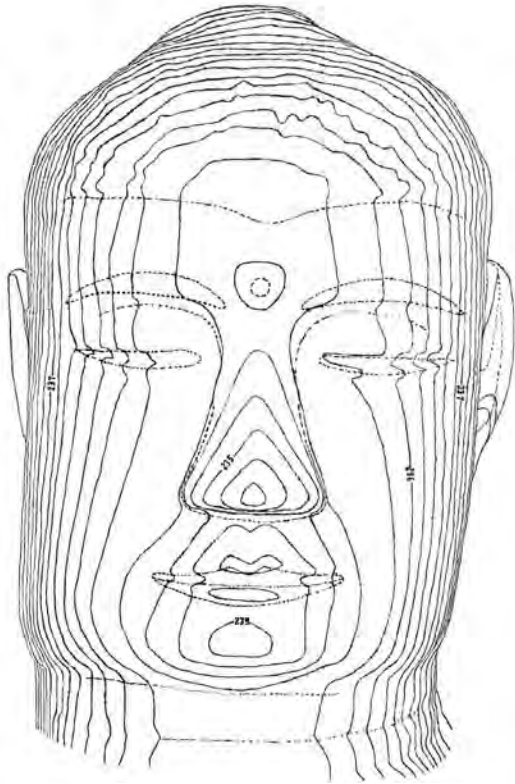

FIGURE 2 Stereoscopic map of the head of the Leshan Buddha.

- to detect cracks in the stone core, which resulted from the removal of the excess rock; and
- to locate the cracking points, from which seepage from the external shell occurs.

With this examination we also hoped to clarify the following questions and assumptions:

- Why does the Buddha seem to shed tears, have a running nose, and drip saliva for two to three days after moderate rain (10–25 mm/day)?
- Some scholars believe that the statue originally had a raised right arm that was later broken at the elbow and restored with other materials to the current position with the arm resting on the leg. This belief has been held for decades and still holds much currency today.¹
- Some scholars believe that the statue’s feet are not the original ones, which purportedly had been worn away and replaced with new ones made of other materials.

Results

The results are as follows:

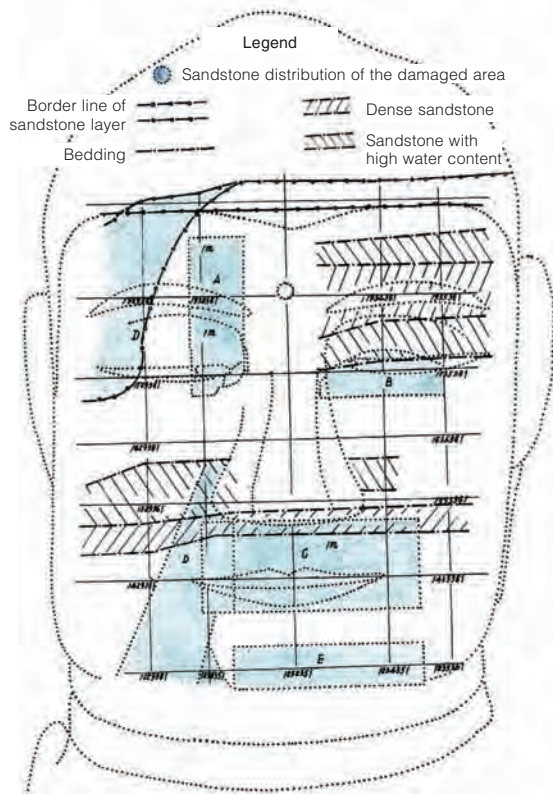

FIGURE 3 Distribution of the damaged areas.

1. The statue’s forehead was carved from the cliff face, and it was then topped with lime mortar and a separately carved topknot. Electrical resistivity and sound wave instruments detected the joint between the forehead and the topknot. Rainwater is thus able to infiltrate the joint, enter the cracks in the head, and eventually seep out through the external shell.
2. Measurements of the thickness of the external shell were obtained: face, 10–50 centimeters; torso, 0–40 centimeters; hands, 20–40 centimeters; arms, 30–100 centimeters; feet, 60–120 centimeters. Measurements of the depth of weathering of the shoulder and torso that lack shell were also obtained; they range from 5 to 20 centimeters.
3. Deterioration points on the face were detected and their depths measured. The larger ones are located at the eyes, nose, mouth, and chin. A fractured triangular piece fell off at some point and became the major channel of the water coming from the top of the head (fig. 3).

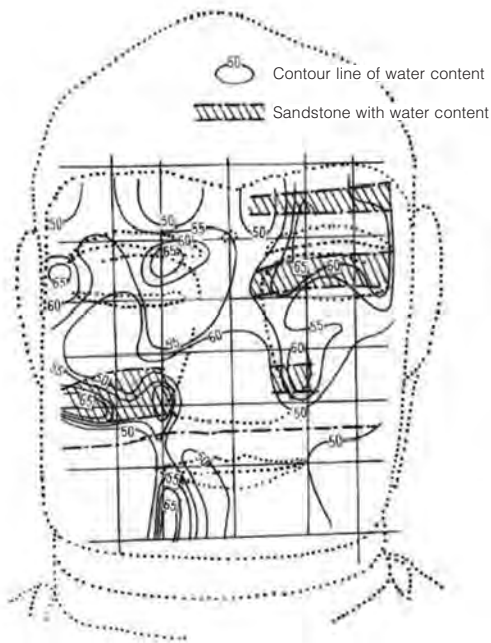

FIGURE 4 Moisture content map.

4. The right arm is intact. There is no evidence of fracture at the elbow. The current position of this arm is identical to the original one.
5. The feet are intact; only the right foot has suffered more damage from weathering.
6. The seepage areas were located (fig. 4). These were found near the eyes, the corners of the right eye, the right side of the nose, and the right side of the mouth, which correlate with the major damage on the face. Thus rainwater from the head seeps into the joint, drains from these damaged areas, and enters the external shell. This explains why the Buddha seems to cry even two or three days after rain.
7. A few large cracks that resulted from carving were discovered. The crack that cuts through the two knees poses the most danger to the statue.

Certain adjustments to procedures were necessary during examination with the geophysical instruments. The neutron probe sensor, which works by emitting neutron particles from a source, measures the moisture, but it could penetrate only to a depth of 7 centimeters. The thickness of the external shell of the facial part of the Buddha is 10 to 50 centimeters, and it is impossible for the instrument to locate the

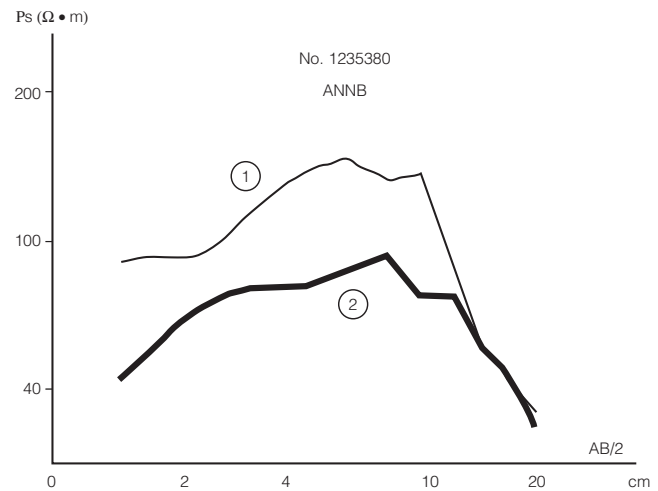

FIGURE 5 Contrast between two resistivity sounding curves (1) before rain and (2) after rain.

actual leaking points in the stone core. We circumvented this problem by using the probe after fifteen days without rain, thereby minimizing the possibility that rainwater had moistened the external shell. It was thus possible to locate accurately those areas with high moisture content, which presumably seeps out from the cracks in the stone core.

Another problem arose when measuring the thickness of the external shell with the electrical resistivity sensor. The instrument measures the different resistivities of the materials in the external shell and the stone core. Normally the material of the external shell has a low resistivity and the stone a high value. But if the shell contains certain other materials, its resistivity becomes high, and if the stone contains water, its resistivity becomes low. This dilemma was overcome by measuring the statue twice: after ten rainless days and after a moderate rain. Because rainwater soaked the shell and drastically changed its resistivity while the resistivity of the stone remained relatively stable, it was possible to detect the interface between the shell and the core by analyzing the different diagrams resulting from the two measurements (fig. 5).

Conclusion

Using geophysical techniques, we have been able to locate the stone core, cracks in the face, and seepage areas. We have also been able to measure the thickness of the external line and clay shell.

Notes

- ¹ This item and the one that follows come from a roundtable discussion of the project group and the Leshan Giant Buddha research and conservation staff in 1990. Unpublished materials.

References

- Zhong Shihang. 2002. Application of geophysical techniques in archeology and conservation in China. *Progress in Geophysics* 17 (3): 498–506.

PART SEVEN

Methods and Treatment



Types of Weathering of the Huashan Rock Paintings

Guo Hong, Han Rubin, Huang Huaiwu, Lan Riyong, and Xie Riwan

Abstract: *The Huashan rock art in China's Guangxi Zhuang Autonomous Region dates from 2400–1600 B.P., though some have been dated to as early as 16,000 B.P. Approximately seventy sites are known, of which Huashan is the most spectacular. The rock is limestone, and the rate of dissolution by water is in excess of 8 millimeters per 100 years. New threats to the art have emerged in recent times: pollution and tourism. While the red ocher pigment of the art is stable and resistant to weathering, it is the limestone substrate that is vulnerable. This paper describes the physical, chemical, and biological deterioration affecting the art.*

Brief Description of the Huashan Rock Paintings

The Zuo River valley in the Guangxi Zhuang Autonomous Region is well known for its rock art, which can be found at more than seventy sites. The most spectacular among them is the Huashan (Hua Mountain), within the Nonggang Nature Reserve in Yaoda district, 25 kilometers from the Ningming county seat. The mountain drops abruptly into the Ming River, a tributary of the Zuo River, with a sheer cliff 270 meters high and 350 meters wide on the western side (fig. 1). The rock paintings are located between 30 and 90 meters above the river and extend for 172 meters, occupying an area of more than 8,000 square meters.

The Huashan rock paintings comprise about 1,600 dancing figures and animals, as well as depictions of bronze drums, knives, swords, bells, and ships. Most of the human figures range in height from 60 to 150 centimeters, but one is 3 meters high. These images probably represent various kinds of worship: sun, bronze drum, river god,

farming god, phallus, war and victory, sacrifice, and totem (Bao Chang 1981). They are therefore important for our understanding of the cultural life of the ancient populations in the Zuo River valley. Existing stylistic studies and carbon-14 dates place the Huashan rock paintings within a time frame of 2400 to 1600 B.P., which coincides with the Warring States period and the Qin and Han dynasties in northern China (Yuan Sixun, Chen Tiemei, and Hu Yanqui 1986; Tan Shengmin 1987: 127–45). Historical records tell us that the Zuo River valley was inhabited by the Luo Yue ethnic group during this time frame; hence the Huashan rock paintings may have been created by them (Wang Kerong, Qiu Zhonglun, and Chen Yuanzhang 1988: 202–8).



FIGURE 1 A view of the Huashan cliff.

Present Condition and Microenvironment of the Huashan Rock Paintings

Topographically, Huashan is part of a karst system. Water seepage and erosion have caused cracking, scaling, and collapse of the rock (fig. 2). They have also given rise to many stalactites and veils on the rock surface (figs. 3, 4). Some of the rock paintings were executed on these formations. According to carbon-14 dating, the earliest paintings were made about 16,000 B.P. and the most recent ones about 690 B.P. Dissolution is still occurring at the rate of 2.1 to 8.3 mm/100y. Where water seepage is severe, the rate is even greater (Chen Tiemei, Chen X., and Zhu F. 1986). Seepage and erosion are the immediate threats to the paintings.

Huashan is located in a subtropical monsoon climatic zone, characterized by high temperature and abundant rainfall. Annual average temperature is 19°C to 22°C (highest, 26–28°C; lowest, 11–14°C); the annual rainfall is 1242.2 millimeters (mainly from June to September, 63%) (Ningming County Weather Bureau).

Huashan is a remote area and has been free from industrial activities for thousands of years, which has favored the



FIGURE 2 Weathering of the rock paintings on the Huashan cliff.



FIGURE 3 Stalactites and curtains on the Huashan cliff.



FIGURE 4 Granular substance on the Huashan cliff.

preservation of the rock art. In recent decades, however, paper making, sugar production, and coal mining have been developed at the county seat of Ningming, 25 kilometers upstream, and pollution has spread to Huashan. Moreover, the increasing number of tourists visiting the site poses a great threat to the preservation of the rock paintings.

Painting Materials

The Huashan rock paintings were all executed with red ochre, which was applied directly onto the rock face. The rock body is limestone, mainly calcium carbonate (CaCO_3), as revealed by X-ray diffraction (XRD) and X-ray fluorescence (XRF)

analyses (Guo Hong et al. 2005: 10–20). Analyses of the structural features and composition of the rock show it is limestone and marl, both containing fossil fragments. The fossil remains in the limestone are mostly perfectly preserved, with a lamellar structure of 30 to 45 percent by volume (fig. 5). The cementation substances are mostly calcite and micritic carbonate, which suggests that the sedimentation environment was a calm one, containing foraminifera, marine algae, and invertebrates. The marl comprises conglomerates and granules of micritic carbonates, and the cementation substance is calcite; it also contains marine invertebrates.

In spite of weathering for centuries, the color of the red ocher pigment is bright. X-ray spectroscopic analysis shows that in addition to the predominant iron, the elements are calcium, magnesium, silicon, aluminum, sodium, potassium, zinc, vanadium, sulfur, titanium, and nickel. XRD analysis reveals that the major color-generating element is Fe_2O_3 , but calcite, quartz, and kaolin are also found. The analyses indicate that the pigment was derived from natural red ocher mixed with clay. Ocher, as is generally known, has high resistance to heat and humidity and is stable chemically.

Ultraviolet and infrared spectroscopic examination shows that conifer resin was used as the binding medium. The resin is insoluble in water and undoubtedly has contributed to the preservation of the rock paintings over the centuries (Qiu Zhonglun et al. 1990).

Microscopic Examination

Examination using the optical microscope shows that microscopic weathering occurs by erosion, microorganisms, surface deposits, and microscopic cracks.

Erosion

Erosion is the most common type of weathering, creating various types of pits on the rock face (fig. 6). Pits take a number of forms, such as trough, basin, and pothole. Some basin-form pits contain residues of erosion that reflect their formation process. The residue on the bottom is loose in texture and dull in color; the bottom itself is composed of many tiny cracks filled with black carbonates and oxides. It appears that the basin developed as microscopic cracks expanded. The pothole is a baglike pit with a small mouth but a large interior. The walls of the pit are loose and porous and sometimes contain calcite and limestone particles coming from the outside. Erosion holes are on average 0.54 millimeter in diameter.

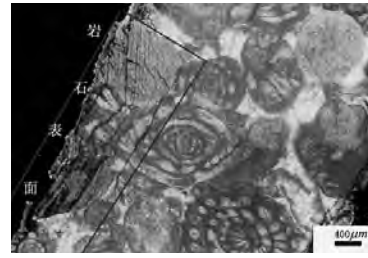

FIGURE 5 Polished, embedded thin section of Huashan rock, showing marine invertebrate fossils.

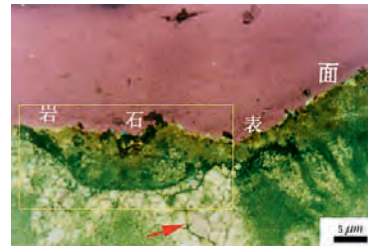

FIGURE 6 Polished, embedded thin section of Huashan rock, showing erosion pits on the surface due to weathering.

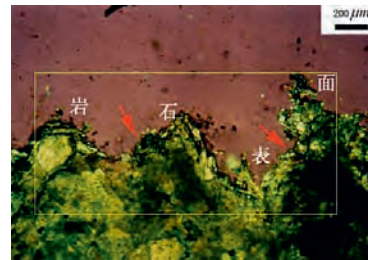

FIGURE 7 Polished, embedded thin section of Huashan rock, showing deep weathering (up to 0.8 mm) resulting from microbiological growth.

Microorganisms

As shown in figure 7, the growth of microorganisms penetrates into the rock to a depth of 0.5 to 0.8 millimeter and is less than 0.001 millimeter in diameter.

Surface Deposits

There are two types of surface deposits. One is chemically formed (e.g., a surface precipitate or veil together with granular lime), and the other is physically or biologically formed. They are different in structure, composition, and thickness.

The chemically formed deposit appears to result from the precipitation of calcite. It is characterized by a clearly visible layer structure, with light- and dark-colored layers alternating.

The light-colored layers are mainly crystalline calcite and are denser in texture than the dark-colored ones. The dark-colored layers are highly porous and composed mainly of noncrystalline calcite with organic material and other inclusions; they also contain tiny particles of quartz and feldspar.

The physical-biological mechanism deposits result from wind and water, by which particles carried to the rock surface adhere and provide a substrate for microorganisms. They are characterized by thinness and a considerable amount of clay, calcite, and quartz. Compared with the chemically formed deposit, this type is very thin and therefore also described as a deposit film. The particles of clay, calcite, or quartz are usually 0.03 to 0.06 millimeter in diameter, and the cementation substances are mainly clay and calcium carbonate. Some of the particles fill the erosion pits. Obviously, they are intrusions, accumulated by water or wind on the surface and then cemented by carbonate.

Microscopic Cracks

There are two types of microscopic cracks: those with carbonate filler (fig. 8) and those without (see fig. 7) (Yang Zhong-Tang et al. 1994). Our examination found that the fissures without fill are more developed and larger horizontally than in other directions. That they cut into rock but show no displacement indicates that they are stress relief cracks. The large number of this type of crack significantly weakens the cohesion of the rock surface and leads eventually to scaling. This type of weathering is very detrimental to the rock paintings.

Causes of Weathering

The foregoing analysis of the microscopic forms of weathering suggests three causes: chemical, physical, and biological. Chemical weathering produces pits in the rock and carbonate coverings on the surface. The subterranean water in the Huashan has a rich content of chemical substances that

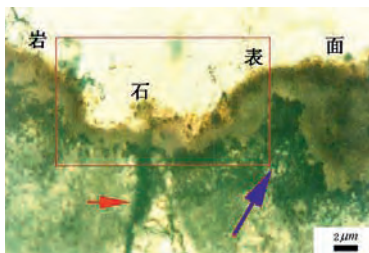

FIGURE 8 Polished thin section of Huashan rock with microscopic cracks filled with carbonate.

accounts for the above-mentioned features. Analysis of water samples from a spring and a stalactite in the Huashan and the Ming River reveals the different chemical compositions of these sources (table 1). Table 1 shows that (1) the mineralization of the river water is lower than that of the stalactite water, which is lower than that of the spring, indicating that the spring water had been in contact with the rock for less time than the stalactite water; (2) the content of Ca^{2+} , Mg^{2+} , and HCO_3^- ions of the spring and stalactite is higher than that of the river water, denoting a considerable dissolution by the subterranean water, which results in caverns, cracks, and pits, thus undermining the stability of the rock (it also reprecipitates calcium carbonate on the surface of the rock, concealing the rock paintings); (3) the content of Cl^- ion in the river water is higher than that of the spring and stalactite water, indicating that the river is slightly polluted.

Physical weathering begins with the microscopic cracks. The existence and development of these cracks change the mechanical properties of the rock, which in turn leads to loss of fragments that vary in size from one to many square centimeters, the largest being hundreds of square centimeters. These fragments are generally up to 1 to 2 centimeters thick. This type of erosion, which is determined by the structure of the rock, the development of the cracks, and the atmospheric conditions, is most hazardous to the paintings.

Biological weathering derives from microorganisms. Growth of microorganisms on the rock surface and intrusion into the rock affect both the surface and the interior. Holes inside the erosion pits, for instance, are caused by microorganisms such as lichen and algae. Deep holes that penetrate into the light- and dark-colored layers may have been produced by the decomposition of threadlike algae. Microorganisms, when combined with the other forces of erosion, may also significantly damage the rock paintings.

Pigment

The ochre pigment is rosy to dark red in color. The pigment layer is usually 0.01 to 0.03 millimeter thick but occasionally is up to 0.04 millimeter thick. Because the pigment was applied on a weathered surface, it tends to penetrate the rock. The extent of penetration depends largely on the structure of the rock and is greatest where microfissures exist. A cross section shows that the pigment penetrates deeply along the lamellar structures and turns the cement inside into a brownish yellow color (fig. 9). The pigment therefore may have helped to strengthen the weathered rock surface.

Table 1 Water Analysis

Chemical Composition	Content (mg/l)			
	River	Spring	Stalactite (north side)	Stalactite (south side)
Na ⁺ K ⁺	14.75	13.00	19.75	15.5
Ca ²⁺	12.7	83.81	45.9	46.58
Mg ²⁺	4.81	6.93	5.94	6.45
Cl ⁻	16.31	13.47	15.6	14.18
SO ₄ ²⁻	15.22	9.89	31.95	31.95
HCO ₃ ⁻	51.26	285.57	150.11	146.45
Degree of mineralization	115.05	412.67	269.25	261.11
pH value	6.51	7.52	6.85	6.8

Source: Liu Yourong and Pan Bietong 1991.

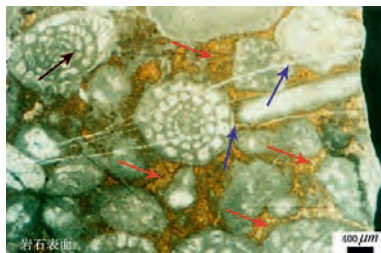

FIGURE 9 Polished thin section of Huashan rock, showing penetration of ocher into weathering microfissures that existed at the time the pigment was applied.

Conclusion

The Huashan rock paintings were created by applying red ocher directly onto the limestone rock surface. While ocher is quite stable, the rock is prone to weathering. This study has examined the microscopic forms of weathering of rock. The major form is erosion pits, but surface deposits, microscopic cracks, and holes drilled by microorganisms are also found. The underlying causes of these forms of deterioration are the chemically rich underground water acting on the limestone, development of microscopic cracks, and the growth of microorganisms. Located in a karst topography, the overall site is most threatened by the underground water.

References

Bao Chang. 1981. The origin of dance. *Wudao luncong = Dance Tribune* 4: 58–63.

Chen Tiemei, Chen X., and Zhu F. 1986. ¹⁴C dating of rock paintings at Huashan Mountain, Guangxi. *Guangxi min zu yan jiu = Study of Nationalities in Guangxi* 2: 69–72.

Guo Hong, Han Rubin, Zhao Jing, Huang Huaiwu, Xie Riwan, and Lan Riyong. 2005. Pigment and the prevention of its fading on petroglyphs of the Flower Mountain. *Wen wu bao hu yu kao gu ke xue = Sciences of Conservation & Archaeology* 17 (4): 7–14.

Liu Yourong and Pan Bietong. 1991. Geological problems and preventive measures for the Huashan rock paintings in Guangxi. Unpublished internal report. Archived in the Cultural Property Bureau of the Provincial Cultural Administration, Guangxi Zhuang Autonomous Region.

Qiu Zhonglun, Li Qianrong, Pan Xiaomei, and Wang Changsui. 1990. A preliminary study of the pigment and binding medium of the Huashan rock paintings. *Wen wu* (1959) = *Wen wu* 1: 85–87.

Tan Shengmin. 1987. *Guangxi Zuo Jiang liu yu ya bi hua kao cha yu yan jiu = Investigation and study of the rock art of the Zuojiang River valley in Guangxi*. Guangxi shao shu min zu gu ji cong shu, no. 1. Nanning Shi: Guangxi min zu chu ban she.

Wang Kerong, Qiu Zhonglun, and Chen Yuanzhang. 1988. *Guangxi Zuo Jiang yan hua*. Beijing: Wen wu chu ban she.

Yang Zhong-Tang, Zhen Guangquan, Ma Tao, and He Ling. 1994. Study of the microfeatures of the weathered stone relics in Qianling Mausoleum. *Kaogu yu wenwu = Archaeology and Cultural Relics*, no. 6: 20–25.

Yuan Sixun, Chen Tiemei, and Hu Yanqui. 1986. ¹⁴C dating of rock paintings on the Huashan Mountain, Ningming County, Guangxi Zhuang Autonomous Region. *Guangxi min zu yan jiu = Study of Nationalities in Guangxi* 4: 27–33.

A Study of Support Materials for Mural Paintings in Humid Environments

Ma Qinglin, Chen Genling, Lu Yanling, and Li Zuixiong

Abstract: *Microorganisms are a tremendous threat to organic materials in humid environments. This paper presents our research on the selection of support materials for mural paintings in humid areas and X-ray diffraction, Fourier transform infrared, polarized light microscope, and scanning electron microscope analysis of the texture, mechanism, and form of fixed and slaked calcareous nodules (liaojiang) used as the source material for mortar. We conclude that the ideal material for backing mural paintings in humid environments is the inorganic mortar made from liaojiang.*

A joint research project was carried out between 1987 and 1996 by the Gansu Provincial Museum, China, the Coating Materials Institute of the Ministry of Chemical Industries, and the Lanzhou University Department of Biology in order to find solutions to the need for reinforcement materials and techniques and the prevention of mold on mural paintings in humid environments.¹ The project succeeded in identifying the causes of such deterioration problems and effectively protecting the surface of paintings from decay.

In addition to the frequently observed damage caused by soluble salts, a further danger for mural paintings that have been lifted and detached is that stress between the painting's backing and the support wall, or the stress of the backing layer itself, may cause cracking or detachment in the painting, threatening its secure attachment to the wall. In dry environments, high-fiber materials such as straw or hemp mixed with adhesive materials are satisfactory to enhance the intensity of the clay-based layer, but for paintings in a humid environment, where spores of microorganisms develop as soon as the environment is proper for their growth, these organic materials are not appropriate. In

tombs where paintings have been reattached, a typical relative humidity of 75 percent and an average temperature of 8°C to 25°C contribute to the growth of spores. Under these conditions, the development of spores weakens the organic substrate materials. In addition, metabolic substances produced by microorganisms are detrimental to the paintings (Ma Qinglin, Hu Zhide, and Li Zuixiong 1996).

In 1996 the Gansu Provincial Museum started work on a national project, Backing Materials and Protection Techniques for Mural Paintings in Humid Environments. As microorganisms had already done great damage to the paintings, special attention was paid to the choice of inorganic adhesive mortars to adhere the detached clay-based layer.

History of Inorganic Mortars

Inorganic mortars have a long history in China. In ancient construction sites unearthed in Dadiwan, Qin'an county, Gansu province, especially at Sites F901 and F405, components in the flooring were made from calcium carbonate agglomerations found in loess. These nodules, called *liaojiang*, contain 60 to 80 percent CaCO_3 and 2 to 40 percent clay minerals. Fired *liaojiang* is generally believed to be the oldest man-made cement in the world (Li Zuixiong 1998). On the floor of Site F411 is China's oldest-known painting, dated at five thousand years. This work, referred to as the Dadiwan floor painting, measures about 1.2 meters long and 1.1 meters wide. The backing of the painting is similar to the floor of the hall of Site F901 (Lang Shude 1999). The floor painting was transferred to the city of Lanzhou for protection, and samples from the underlying support were studied in the laboratory.

Since the relative humidity in underground tombs is greater than 75 percent year-round, inorganic support materials for murals must harden slowly in reaction with water. Hardening must be slow to allow for minor expansion, aeration, and water vapor permeability for the reinforcement layer.

The Italian technique of using volcanic ash (*pozzolana*) in the restoration of underground mural paintings is well known (Schwartzbaum et al. 1984). Volcanic ash is chemically similar to fired *liaojiang*. The Dadiwan floor painting had been buried underground for nearly five thousand years but incurred no damage and remains strong and intact. This means that the mortar used is long lasting and ideal in a stable humid environment. We thus decided to research the application of similar materials for reinforcing the backing of mural paintings in humid environments.

Liaojiang as a Hydraulic Adhesive

Composition

Liaojiang, calcareous nodules that form in loess, contains a large percentage of CaCO_3 and other minerals such as clay, quartz, mica, and feldspar. The nodules are white, gray, light yellow, or even red in color, and the higher the clay mineral content, the darker the color.

We used X-ray diffraction (XRD), Fourier transform infrared (FTIR), polarized light microscope (PLM), and scanning electron microscope (SEM) analysis, as well as other techniques, to examine *liaojiang* nodules obtained near the site of the Dadiwan floor painting. The results, reported in table 1, show that the nodules contain about 66 percent

calcite ($\text{CaO} + \text{CO}_2$), 22 percent quartz, and some mica and feldspar. Previous research has shown that the endurance of ancient building materials derives from the low percentage of Na_2O and K_2O (3–20%) and the high CaO content (40–50%) (Yang Nanru 1996).

Analytical Methods

XRD Analysis

Unfired *liaojiang* samples were heated to a high temperature (700–1,000°C) and allowed to cool to room temperature. The samples were then ground to a fine powder, sifted, and mixed with water. The mixture was spread into 0.5-centimeter-thin analytical samples, similar to the flakes found in the clay-based layer of the wall painting, and kept in an environment of 90 to 100 percent RH for one month. The composition obtained through XRD analysis of the *liaojiang* powder before hydration and the prepared analytical samples after one month in a high relative humidity environment is presented in table 2.

The analyses show that although the unfired *liaojiang* is composed mainly of calcite and quartz, the high-temperature heating changed the composition greatly. The calcite decomposed into CaO , which was converted into reactive minerals such as CaAl_2O_4 ($\text{CaO}\cdot\text{Al}_2\text{O}_3$), $\text{Ca}_2\text{Al}_2\text{SiO}_7$ ($2\text{CaO}\cdot\text{Al}_2\text{O}_3\cdot\text{SiO}_2$), and CaSiO_3 ($\text{CaO}\cdot\text{SiO}_2$). After the powder was exposed to high relative humidity for one month, the composition of the samples changed into $\text{Ca}_{1.5}\text{SiO}_{3.5}\cdot x\text{H}_2\text{O}$ ($1.5\text{CaO}\cdot\text{SiO}_2\cdot x\text{H}_2\text{O}$) and $\text{Ca}(\text{OH})_2$ and a small amount of CaCO_3 (since the samples were not exposed to air, little CaCO_3 was produced).

Table 1 Composition of *Liaojiang* Nodules^a, Red Clay, and Modern Cements (wt %)

Sample	SiO_2	Al_2O_3	Fe_2O_3	CaO	MgO	K_2O	Na_2O	CO_2	SO_2
Red clay	62.15	15.79	6.45	1.06	3.22	3.08	1.14	0.07	
<i>Liaojiang</i>	22.06	5.44	2.03	36.82	1.49	0.98	0.60	28.4	
<i>Liaojiang</i> ^b	20.62	5.02	2.03	37.60	1.38			31.56	
<i>Liaojiang</i> ^c	20.9	5.3	4.4	65.2	1.8				1.7
Silicon cement	21–23	5–7	3–5	64–68					
Common cement ^c	21.2	5.4	2.7	64.7	2.0				2.1

a. Samples obtained from near the Dadiwan archaeological site in Qin'an county.

b. See Chen Ruiyun 1992.

c. See K. Asaga et al. 2000.

Table 2 Composition of Powdered, Heated-Treated *Liaojiang* Samples Obtained through XRD Analysis

Heating Temperature (°C)	Before Hydration ^a	1 Month after Hydration
700	SiO ₂ , CaO, Al ₂ O ₃ , small amount of CaO·Al ₂ O ₃	SiO ₂ , Ca _{1.5} SiO _{3.5} ·xH ₂ O, Ca(OH) ₂ , small amount of CaCO ₃
800	SiO ₂ CaO, 2CaO·Al ₂ O ₃ ·SiO ₂	SiO ₂ , Ca(OH) ₂ , Ca _{1.5} SiO _{3.5} ·xH ₂ O, small amount of CaCO ₃
900	SiO ₂ , CaO, 2CaO·Al ₂ O ₃ ·SiO ₂	SiO ₂ , Ca(OH) ₂ , Ca _{1.5} SiO _{3.5} ·xH ₂ O, small amounts of 2CaO·Al ₂ O ₃ ·SiO ₂ and CaCO ₃
1,000	SiO ₂ , CaO, 2CaO·Al ₂ O ₃ ·SiO ₂ , CaO·SiO ₂	Ca(OH) ₂ , Ca _{1.5} SiO _{3.5} ·xH ₂ O, small amounts of CaAl ₂ O ₄ , CaCO ₃ , and 2CaO·Al ₂ O ₃ ·SiO ₂

a. Exposure to 90–100% RH.

FTIR Analysis

Samples prepared for XRD analysis were used to determine FTIR spectra. The results are shown in figures 1 through 3.

Comparison of the spectra in figures 1 and 2 shows a large phase transformation. Before hydration there is no CaCO₃ in the samples, but after hydration and exposure to air the CaCO₃ content increases in the regions 1420 cm⁻¹, 873 cm⁻¹, and 712 cm⁻¹. In the regions 3,674–3,300 cm⁻¹ and 996 cm⁻¹, the change shows that hydration also occurs for other substances. The newly formed CaCO₃ appears in the regions 1,420 cm⁻¹, 873 cm⁻¹, and 712 cm⁻¹. Comparison of

figures 2 and 3 shows that the *liaojiang* after hydration is very similar to the material from the Dadiwan floor painting substrate.

PLM Analysis

Samples of heated *liaojiang* powder and samples after hydration were examined under the polarized light microscope. Compared to the raw fired material, the *liaojiang* after hydration has formed many particles of different sizes and shapes, which indicates that after hydration the *liaojiang* has a high degree of cohesion.

FIGURE 1 FTIR spectrum of gray *liaojiang* sample after heating for twenty-four hours at 900°C.

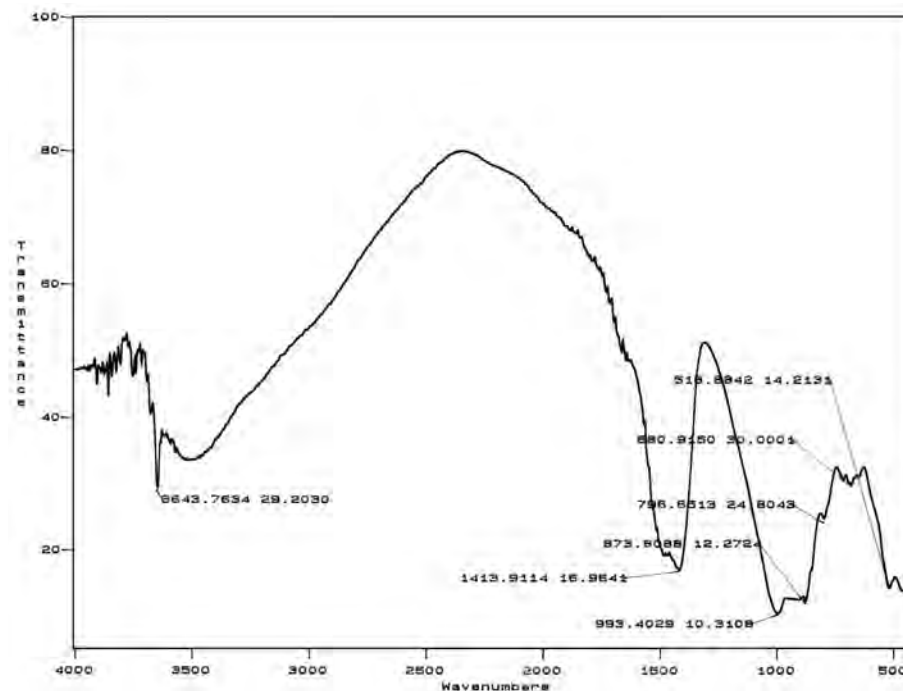

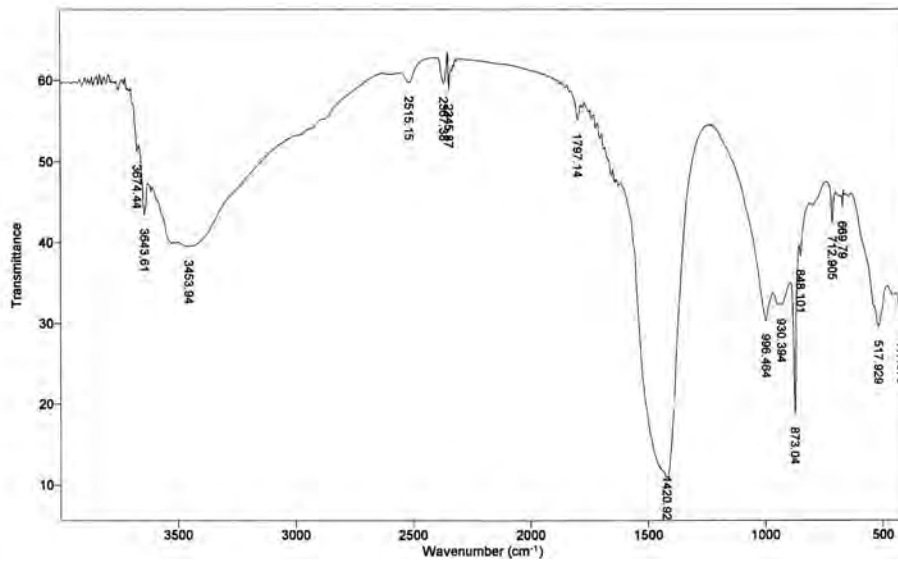

FIGURE 2 FTIR spectrum of *liaojiang* one month after hydration.

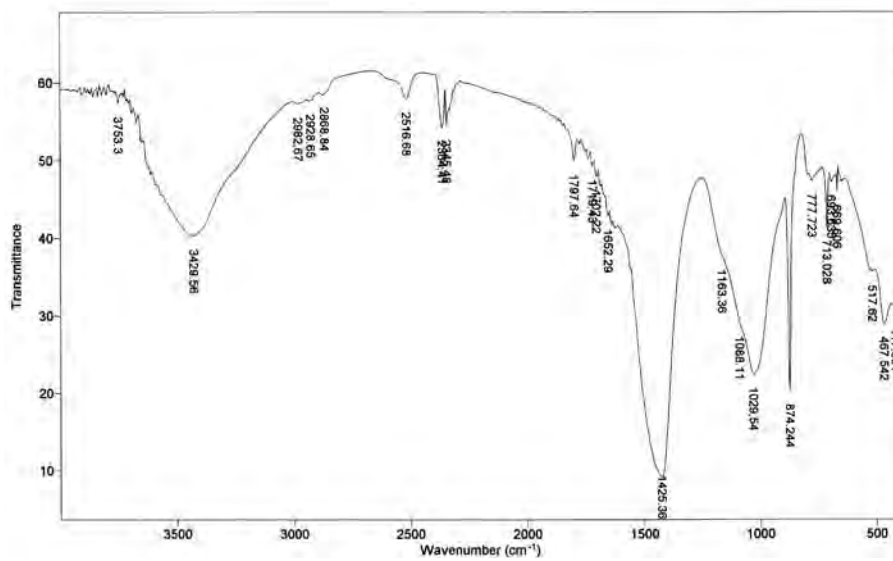
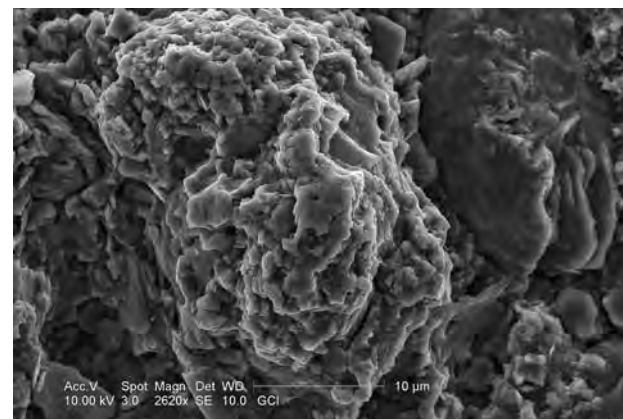

FIGURE 3 FTIR spectrum of the Dadiwan floor painting substrate.

FIGURE 4 SEM image of *liaojiang* sample one month after hydration (2620 \times).

SEM Analysis

Figure 4 shows a sample of *liaojiang* one month after hydration as examined by SEM. The hydrated *liaojiang* has a very high degree of cohesiveness and has formed a continuous interlinking structure; the regular pores between particles ensure aeration and permeability, thus allowing thorough carbonation over time; that is, the CaO will react with CO₂ to form CaCO₃. Three years after hydration the *liaojiang* sample formed well-developed calcite crystals. This means that a restored support for a painting will continue to improve its cohesiveness three years after the work is done.



Curing Process

Calculations demonstrate that the heating temperature used in the Dadiwan floor was about 950°C (Ma Qinglin and Li Xian 1991). The following are the analyses using XRD of the *liaojiang* nodules taken from the Dadiwan site.

From a comparison of figures 5 through 8 (data for figures 7 and 8 are listed in tables 3 and 4), it is concluded that the process of heating and hardening of *liaojiang* at 900°C is

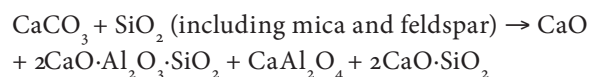

During hydration,

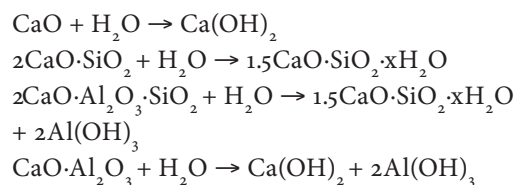

Therefore, the hydrated substances contain a large amount of $1.5\text{CaO}\cdot\text{SiO}_2\cdot x\text{H}_2\text{O}$, Ca(OH)_2 , a small amount of Al(OH)_3 , and some unhydrated $2\text{CaO}\cdot\text{Al}_2\text{O}_3\cdot\text{SiO}_2$. Among them, Al(OH)_3 and $1.5\text{CaO}\cdot\text{SiO}_2\cdot x\text{H}_2\text{O}$ are effective inorganic cementing agents.

Table 3 Data Comparison of Figure 7 and Standard Materials in JCPDS^a Files

Samples		Ca ₂ Al ₂ SiO ₇ (35-0755)		CaO (43-1001)		CaAl ₂ O ₄ (34-440)		SiO ₂ (31-1233)	
dA°	I/I ₀	dA°	I/I ₀	dA°	I/I ₀	dA°	I/I ₀	dA°	I/I ₀
4.2711	18	4.231	2					4.257	22
3.8340	6	3.842	1						
3.7201	8	3.707	15						
3.3508	72							3.342	100
3.2408	9								
3.0640	9	3.0629	21						
2.9781	10					2.97	100		
2.8554	27	2.8446	100			2.86	3		
2.7793	55			2.7777	37				
2.7560	33								
2.7121	21	2.7175	5						
2.6589	10								
2.6361	11								
2.4571	11							2.457	8
2.4062	100	2.4070	11	2.405	100	2.41	18		
2.2861	12	2.2869	11					2.282	8
2.1964	13								
2.0404	9	2.0398	9						
1.9812	8								
1.9111	8	1.9213	8			1.922	8		
1.8192	12							1.8179	14
1.7647	7								
1.7559	8	1.7542	25						
1.7014	48			1.7008	49				
1.5443	9							1.5418	9
1.4507	17			1.4504	13				

a. International Centre for Diffraction Data.

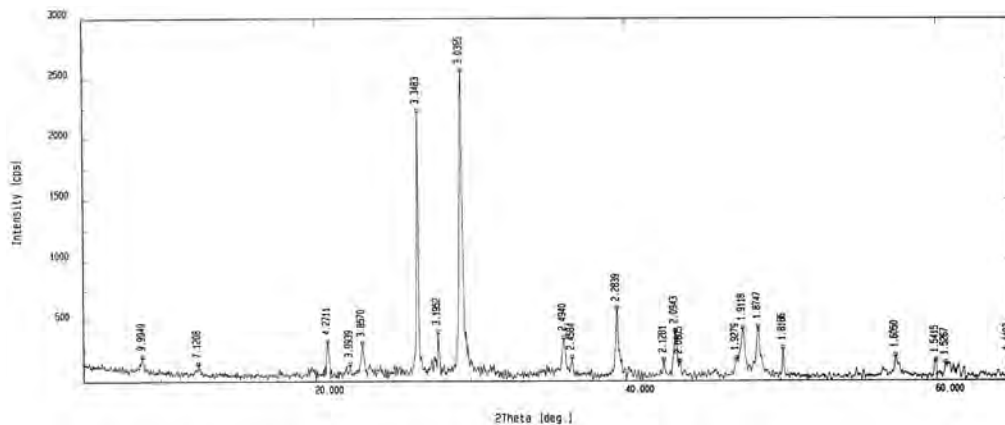

FIGURE 5 XRD analysis of the Dadiwan floor painting substrate (main components, calcite and quartz).

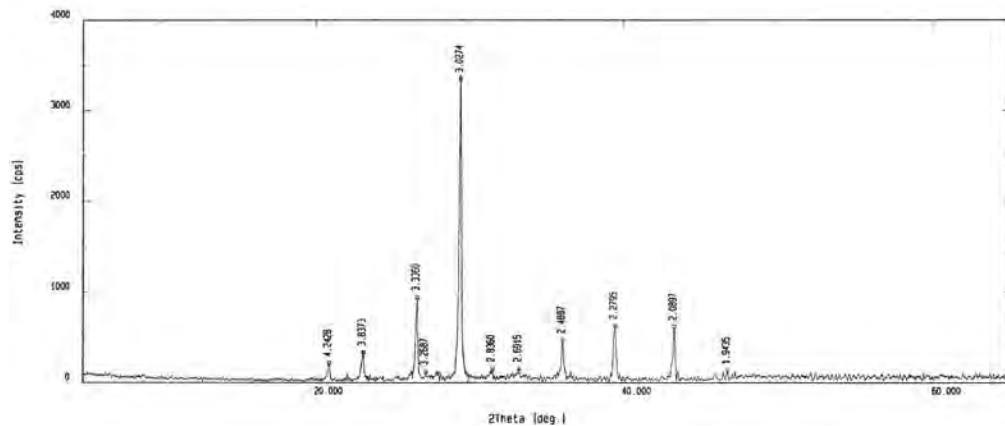

FIGURE 6 XRD analysis of *liaojiang* obtained from loess near the Dadiwan site (main components, calcite and quartz).

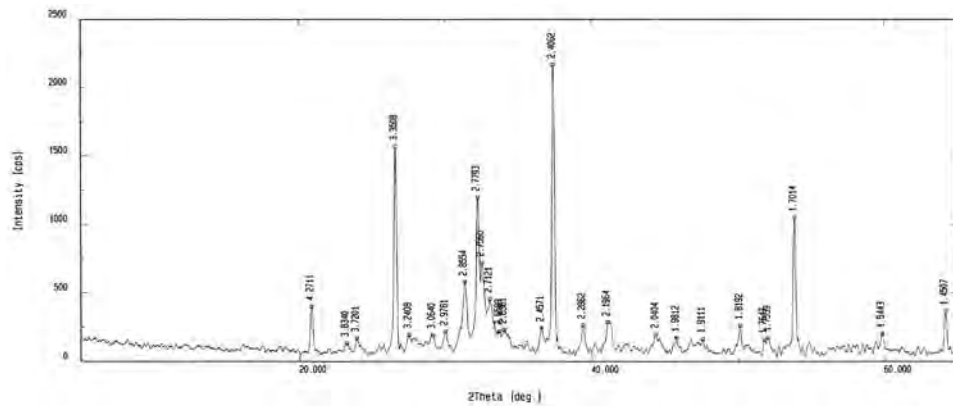

FIGURE 7 XRD analysis of *liaojiang* sample from the Dadiwan site after heating for twenty-four hours at 900°C.

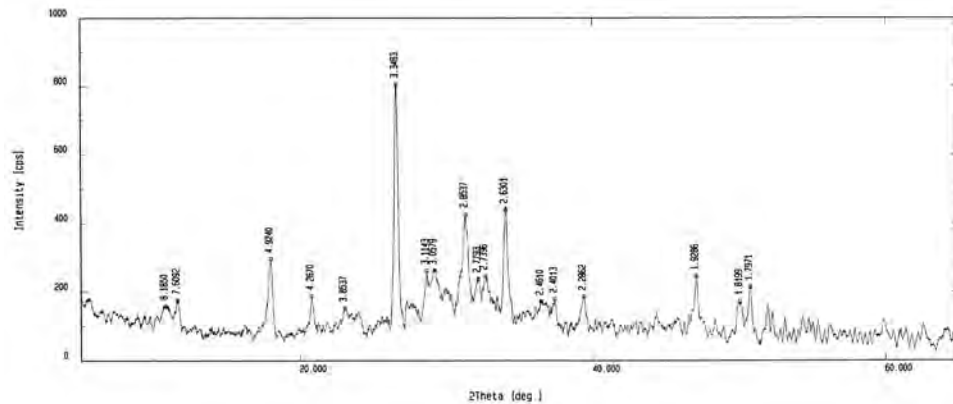

FIGURE 8 XRD analysis of Dadiwan *liaojiang* one month after hydration after heating at 900°C.

Table 4 Data Comparison of Figure 8 and Standard Materials in JCPDS^a Files

Samples		Ca _{1.5} SiO _{3.5} ·xH ₂ O (33-0306)		Ca(OH) ₂ (4-0733)		Ca ₂ Al ₂ SiO ₇ (35-0755)		CaCO ₃ (5-0586)		CaO (43-1001)		SiO ₂ (31-1233)	
dA°	I/I ₀	dA°	I/I ₀	dA°	I/I ₀	dA°	I/I ₀	dA°	I/I ₀	dA°	I/I ₀	dA°	I/I ₀
8.1850	20												
7.6092	22												
4.9240	37			4.90	74								
4.2670	23											4.257	22
3.8537	19							3.86	12				
3.3483	100											3.342	100
3.1143	33			3.112	23								
3.0579	32	3.04	100			3.0629	21	3.035	100				
2.8537	53					2.8446	100	2.845	3				
2.7793	30	2.79	60							2.777	37		
2.7396	31												
2.6301	54			2.628	100								
2.4610	21			2.447 3								2.457	8
2.4013	22					2.3944	12			2.405	100		
2.2862	23					2.2869	11	2.285	18				
1.9286	30			1.927	42	1.9213	8	1.927	5				
1.8199	21	1.82	60									1.8179	14
1.7971	27			1.796	36								

a. International Centre for Diffraction Data.

Two or three days after hydration, a certain degree of cohesion is achieved. At later stages, Ca(OH)₂ absorbs CO₂ from the air and forms CaCO₃ and the hardness progresses:

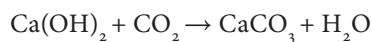

In this way, the mortar calcite becomes durable. Should it decay, the calcite (CaCO₃) formed still retains high cohesiveness. This is the reason the Dadiwan floor painting has survived for five thousand years.

Conclusion

Analysis of the formation and production mechanism of mortar from *liaojiang* nodules indicates that heat-treated *liaojiang* is an ideal substance for use as the support material in the restoration of mural paintings in humid environments.

Acknowledgments

The authors would like to thank Neville Agnew and David A. Scott of the Getty Conservation Institute (GCI) for supporting Ma Qinglin as a visiting scientist while he conducted this research at the GCI in 2001. We also extend thanks to Su Bomin of the Dunhuang Academy, David Carson of the GCI, and Han Jianqing, Tian Xiaolong, and Xu Rui of the Gansu Provincial Museum for samples analysis and preparation.

Notes

- 1 In 1996 the State Administration of Cultural Heritage presented the second Award for Progress in Science and Technology to Gansu Provincial Museum, the Coating Materials Institute of the Chemical Industry Ministry, and the Biology Department of Lanzhou University for their study of the conservation of wall paintings in humid environments—Dingjianzha No. 5 Tomb, Jiuquan, Gansu.

References

- Asaga, K., M. Daimon, Li Zuixiong, and K. Yokozeki. 2000. Reproduction of ancient cementitious material used in China 5,000 years ago. In *Repair, Rehabilitation, and Maintenance of Concrete Structures, and Innovations in Design and Construction: Proceedings: Fourth International Conference, Seoul, Korea, 2000*, ed. V. M. Malhotra, 123–38. Special Publication no. 193. Farmington Hills, MI: American Concrete Institute.
- Chen Ruiyun. 1993. Study of floor materials in the new Stone Age at the site of Dadiwan, Qinan county, Gansu province. *Gui suan yan xue bao = Journal of the Chinese Ceramic Society* 4: 309–18.
- Lang Shude. 1999. [On-the-spot report of the finding and conservation of floor paintings of Dadiwan and F901 prehistoric palace]. In *Gansu wen wu gong zuo wu shi nian*, ed. Gansu Sheng (China), 254–64. Lanzhou: Gansu wen hua chu ban she.
- Li Zuixiong. 1998. The oldest concrete in the world? Restudy of the architectural material of the Yangshao period in China. *Kao gu = Kaogu* 8: 751–57.
- Ma Qinglin, Hu Zhide, and Li Zuixiong. 1996. [Research on microbe corrosion and harm to the pigments in wall paintings.] *Dunhuang Research* 49 (3): 136–44.
- Ma Qinglin, and Li Xian. 1991. [Study of ancient ceramics in Gansu]. *Kao gu = Kaogu* 3: 263–72.
- Schwartzbaum, P. M., I. Massari, G. Pignatelli, and C. Giantomassi. 1984. Approaches to the conservation of mural paintings in underground structures: Case studies of recent projects by ICCROM consultants and staff. In *International Symposium on the Conservation and Restoration of Cultural Property: Conservation and Restoration of Mural Paintings (I): November 17–21, 1983, Tokyo, Japan*, ed. Y. Emoto and S. Miura, 41–58. Tokyo: Organizing Committee of the International Symposium on the Conservation and Restoration of Cultural Property.
- Yang Nanru. 1996. Physical-chemistry foundation of alkali-based cementitious materials 1. *Gui suan yan xue bao = Journal of the Chinese Ceramic Society* 2: 209–15.

Study and Conservation of the Dazhao Temple Wall Painting, Inner Mongolia

Du Xiaoli

Translated by Naomi Hellmann

Abstract: In 1986 an important sixteenth- and seventeenth-century Mongolian Yellow Sect Buddhist wall painting was removed from the Dazhao Temple and taken to Hohhot Museum. Inadequate records, excessive cutting of the wall painting to carry out removal, and the use of epoxy created serious problems for its conservation. This paper describes the technical examination, treatment testing and implementation, and storage conditions of a segment of a wall painting from the monastery complex's Sutra Hall.

The Dazhao Temple, located in the city of Hohhot in Inner Mongolia province, China, was the first Tibetan Yellow Sect Buddhist monastery built on the Mongolian grasslands. Among the structures of the complex, the Sutra Hall is a mixture of Chinese and Tibetan styles. The Tibetan Buddhist wall paintings in the hall are a valuable legacy of early Mongolian Yellow Sect Buddhist temple wall paintings from the sixteenth and seventeenth centuries.

In 1985, when the walls of the Sutra Hall underwent repair, the Department of Cultural Heritage removed 35 square meters, or one-half, of the lower wall painting from the east and west walls in an effort to salvage it. Today the wall painting is held in the Hohhot Museum.

A History of the Removal and Treatment of the Dazhao Temple Wall Painting

Since the removal and relocation of the Dazhao Temple wall painting eighteen years ago, it has been affected by several factors related to the materials used for conservation, the conservation technique, its storage environment, its trans-



FIGURE 1 Detail of the wall painting from the Dazhao Temple.

port from the temple, and the exhibition method (figs. 1, 2). Its condition has deteriorated noticeably, requiring additional conservation measures. For this reason, preliminary research was undertaken on the history of the removal and treatment of the wall painting. However, the principal staff members involved in the undertaking at the time left the department years ago. Individuals were interviewed, and a basic account, given below, was pieced together based on their recollections, but specific details of the materials used, removal, and treatment method are unclear. Incomplete documentation of the removal and treatment of the wall painting has added to the difficulty of undertaking further treatment.



FIGURE 2 Detail of the wall painting from the Dazhao Temple.

Problems Resulting from the Method of Removal

Excessive Incisions. The 34.96-square-meter panel was sliced into 186 irregular pieces and reconstructed into 76 individual sections after treatment (fig. 3). There are twenty-eight areas of 0.67 square meter marred by cuts and twenty areas unmarred by cuts but with relatively large cracks. The remaining sections of the mural are divided into small individual pieces. For example; sections 11–13 titled “Main Buddha” (Huabian Zhuti Fo) (dimensions 2.30 by 1.99, approx. 4.6 m²) were removed in 24 sections and reconstructed as three individual paintings after being treated. These three paintings can be put together to form a completed Buddha figure. The wall painting (fig. 4) was removed in a crude fashion concurrent with the repair of the walls. The section removed primarily depicts images of the Buddha and human figures. Only the Buddha and human figures were retained; the background, primarily depicting nature and living creatures, was abandoned.

Minimal Consideration for the Integrity and Aesthetic of the Painting. In removing and saving parts of the wall painting, consideration was given only to the size of the segment and its appearance as a whole; the integrity of the painting itself was ignored. A transverse cut, in sections 11–55, “Avalokitesvara” (Guanyin Pusa) (dimensions 0.64 by 1.04 m²), cut the legs of the sitting Bodhisattva (Pusa) in two, severing the painting as a whole and diminishing its artistic beauty.



FIGURE 3 Part of the wall painting during reconstruction.

Problems Resulting from the Technique Used to Treat the Painting

Materials. Highly concentrated glue (a mixture of 2 parts hide glue and 1 part alum) was used to strengthen the surface of the painting, and there are visible traces of hardened glue on the parts that were painted white. The back of the painting was treated with epoxy resin as a strengthener. The 2- to 5-centimeter-thick layer of wall removed with the painting was stripped mechanically to a thickness of 1 to 1.7 centimeters. A mixture containing acetone (to dilute the epoxy resin), 5 percent di-n-butylphthalate (DBP) plasticizer, and 10 percent ethylenediamine (EDA) hardener was brushed onto the back surface and penetrated to a depth of 0.5 centimeter. After hardening, another relatively thick layer of epoxy resin was applied to the back, which was then covered in cloth fiber and set in a wood frame. Screws were fastened to the four corners of the mounted wood frame and the wall painting was hung on display.

Epoxy resin was widely used in cultural heritage conservation during the 1980s. At that time the materials and the approach adopted to remove and conserve the Dazhao Temple wall painting were considered relatively advanced. However, epoxy resin becomes extremely hard once it sets, which is incompatible with the strength, cohesiveness, and elasticity of the much weaker “canvas” underside. More than a decade later, the adverse side effects of epoxy resin gradually appeared, creating cracks, displacement, disfiguration,

FIGURE 4 Inappropriate cutting of the wall painting.



FIGURE 5 Adverse effects due to use of epoxy resin.

partial fragmentation, and other serious damage caused by the strength, age, and contamination of the substance (fig. 5).

Technique. After the Dazhao Temple wall painting was removed, not only were different concentrations of the epoxy resin mixture applied to the underside in varying degrees of thickness, but the mixture seeped *through* the cuts and cracks in the painting, penetrating its surface and causing the pigments to harden and become rigid, which is egregious. In the course of treating the painting, rivulets and droplets of the epoxy resin mixture stuck to the painting, damaging the surface and increasing the difficulty of adopting further conservation treatment.

Assessment and Materials Analysis of the Dazhao Temple Wall Painting

Damage Assessment

A history of previous treatment of the painting had to be established so as to discern the damage and interpret the traces of evidence in each segment before a diagnosis could be made and further treatment undertaken. Thirteen kinds of damage were identified (figs. 6, 7) based on a slightly revised version of a system of classification proposed by the Dunhuang Academy, since no international or national standard criteria measuring the condition of a wall painting existed.

The following procedure was used. Each section of the painting was photographed in black-and-white, enlarged to 20 by 30 centimeters, laminated, and annotated—for serious problems a 0.2-millimeter pen was used, and for other problems a 0.13-millimeter pen was used—by comparing the photograph with the corresponding section of the painting. Then each section was outlined. Areas of minute detail were enlarged with a magnifying glass to ensure accurate recording.

Materials Analysis

Pigments. In an analysis undertaken by the National Research Institute for Cultural Properties in Nara, Japan, the pigments were primarily identified as mineral in composition (Du Xiaofan and Takayasu 2000). The analysis revealed two important findings:

- Smalt. The blue glass specks observed in the wall painting are a type of imported cobalt smalt. This is the first use of smalt discovered in a wall painting, which is significant for documenting the source and origins of pigments used in the Dazhao Temple wall painting. Cobalt, potassium carbonate, and silica are components of smalt that create blue, azure, maroon, and wisteria purple colors.

Smalt goes by various names in Chinese (see Gao Lian [Qing dynasty, n.d.]; Song Yingxing [Ming dynasty, n.d.] 1959: chap. 7). An imported blue was used in China during the Yuan dynasty to create blue-and-white (Qinghua) porcelain. A bright sheen and vivid color owing to the lower amount of manganese in imported blue results in a visible luster. The cobalt in a fragment of blue-and-white Yuan dynasty porcelain excavated from the Jining Road archaeological site in 2002 and analyzed by the Inner Mongolian Institute of Archeology is a foreign product presumed to be smalt. It easily could have been introduced into China from central Asia via commercial exchange during the Yuan dynasty. Written documents note that this type of blue was imported from the present-day Arabian Peninsula. Seven or eight types of mainly African and Arabian pigments were among the variety of goods imported into China during the fifteenth and sixteenth centuries (Fei Xin 1928). Porcelain fired during the reigns of Yongle and Xuande (in the Ming period) in official kilns is still prized.

Pigment was transported inland from northwestern China through Turpan until 1596 C.E. (Shen Fuwei 1985: 309). Dazhao Temple was constructed in 1580 as a result of the Chabu Qiale Charter meeting led by Andahan (Altan Khan) and the Third Dalai Lama, in Sonam Gyatso province,

Qinghai, which adopted Buddhism and abolished Shamanism (Shen Fuwei 1985). The Dazhao Temple wall paintings were directly influenced by the artistry of the Ta'er Temple wall paintings in Qinghai.

The meaning, style, composition, layout, and color used, especially the strong red and blue of the wall painting, are full of local flavor and characteristics. Smalt found in the Dazhao Temple wall paintings is therefore closely linked with Silk Road trade over the Mongolian grasslands and with the spread of Tibetan Buddhist culture.

- Color indicators. Markings with a special function were discovered in the pigment analysis undertaken by the National Research Institute for Cultural Properties in Nara (Du Xiaofan and Takayasu 2000). In creating a sketch, the artist would annotate the color with a corresponding symbol, using a specific character for each color.

An infrared laser was used to examine a piece of 7- by 10-centimeter wall painting. It revealed two Chinese characters written in black ink underneath red and blue pigments (fig. 8). Another nine Chinese characters were discovered later during the project. Based on these studies, some characters were used to indicate color used for painting and some to mark the object to be painted. For instance, the Chinese character *gong* was marked for red pigment; the Chinese numerical character *one* was



FIGURE 6 Powdering and loss in the wall painting.

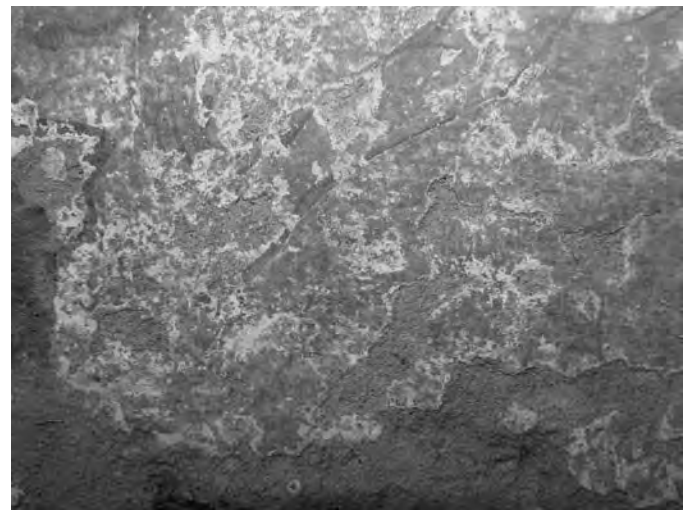

FIGURE 7 Flaking and paint loss.

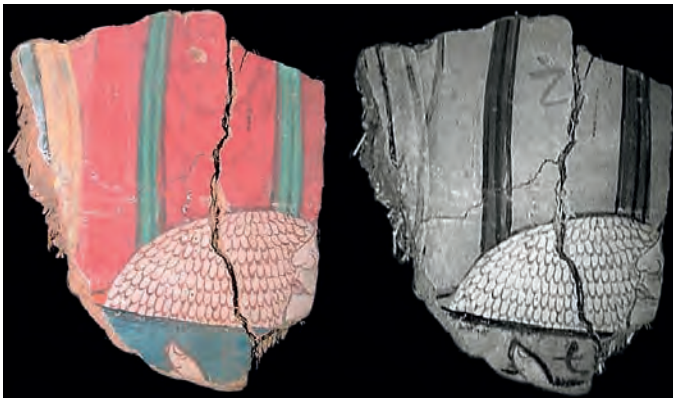

FIGURE 8 Infrared photography revealed Chinese characters specifying colors to be used (right-hand image).

marked for beige color; and the Chinese character *rice* was marked for painting grain.

According to Liu Lingcang,¹ a traditional Chinese wall painting was created in a three-step process. A charcoal sketch was outlined in ink, followed by a final indication of color for apprentices to follow. Master painters would outline in ink leaving an indication of the color. The following are examples of number characters and their color equivalent: *gong*, red; *yi*, off-white; *er*, light blue-gray; *san*, taupe; *si*, pink; *wu*, pale fuchsia; *liu*, green; *qi*, charcoal; *ba*, yellow; *jiu*, purple; and *shi*, black.

So far, all the characters discovered in the Dazhao Temple wall painting have matched up perfectly. The only exceptions are the two sashes, one uncolored and the other in green but both marked with a *liu*. It is apparent that the former was overlooked. The discovery of these characters supports previous literature describing master painters who created an ink outline using a numeric equivalent for the color to be applied by apprentices. It also explains the strong regional and ethnic character evident throughout the wall paintings, which were painted according to traditional technique but which also adopted the Mongolian and Tibetan approaches to using color.

Soil Analysis. The Dazhao Temple wall painting was painted on an earthen plaster of local origin. However, the

surroundings of the temple have been changed. To learn the origin of the clay used for making plaster, three types of analyses were conducted on the original plaster and samples of local soil in order to distinguish between them and produce new plaster essentially identical to or closely resembling the wall painting's original one. Based on the pH and compositional analyses, the soil closest to the original was selected for making the new plaster.

Conservation Research

Testing to Strengthen the Surface of the Painting

Materials.

- i. Solvent: distilled water
 - ii. Consolidating agent: gelatin, polyvinyl alcohol (PVA)
 - iii. Sample wall painting 1: 10 by 8.5 cm
Sample wall painting 2: 15.6 by 17.5 cm
 - iv. Concentrations: 0.5%, 1%, 1.5%, 2%
- Comparative consolidation experiments were made with the gelatin solution and PVA solution.

Procedure. Fragile areas were slowly infiltrated with the relatively weak solutions using the teat of an infant's pacifier. Following infiltration, the area was again treated, this time with a stronger solution. After saturation, a wood press and a roller were used to apply light pressure over a padding of paper-based restoration material. Finally, a metal press was used to flatten fine creases.

Results.

- i. The gelatin resulted in gloss in certain areas, but dissolved easily, had good penetration, and was reversible. The pigment color was not affected.
- ii. As a strong substance that hardened the layer of pigment, the poly(vinyl alcohol) solution was somewhat inferior. The color of the pigment was slightly affected: a change occurred that intensified with increased concentration; and the yellow areas faded visibly. Application was terminated.

Surface Sheen

Treating the surface with the gelatin solution produced a gloss in some areas, primarily on the white and gray and

slightly on the red of the faces, hands, and sleeves of people and the clouds. The consolidant had less penetration on the smooth, nonpowdering area and nonflaking painted layer, and this resulted in surface sheen.

Remedial Measures.

- i. Hot distilled water was used to clean glossy spots and reverse them to their original condition before they were treated with a dilute solution.
- ii. Pigment not severely disintegrated was treated by repeated applications of a weak solution. This also prevented gloss.
- iii. In areas of extreme disintegration, such as those with green and red pigments, a 2% gelatin solution was applied directly, regulating the surface area of each drop of solvent, controlling the time and amount of each interval, and carefully monitoring the penetration of the consolidant.

Surface Epoxy Resin Removal. The reagents ethanol and acetone were used. The surface of the painting was marred by dribbles and droplets of epoxy resin. A Q-tip with acetone or ethanol was gently rubbed to soften the epoxy resin. A scalpel was used to scrape away the white powder, stopping before touching the pigment. Acetone was originally used as a thinner for epoxy resin, and based on this, a slight difference was noted in the process of experimentation between the ability of acetone and ethanol to soften the resin. Acetone is slightly stronger than ethanol but leaves marks that must be treated. Neither reagent adversely affected the pigment layer. Parts of the wall painting marred by epoxy resin that penetrated the pigment layer will not be treated until the appropriate technique and materials are available.

Separating the Backing Layer of Epoxy Resin. Epoxy resin becomes extremely hard on setting, and no method currently exists to directly extract it when it has thoroughly infiltrated a porous material. A hand-operated saw was used to cut away the resin-infiltrated backing. The sliced areas typically measured 5 square centimeters. To separate the layer of epoxy resin from a segment of the wall painting only 1.59 square meters in size, the epoxy resin had to be cut into 592 pieces, which left a layer of plaster about 0.2 centimeter deep. Work was executed extremely slowly and precisely. The layer of plaster was undamaged and in present-day terms, the separation is considered a success.

Repairing Fractures in the Painting

The pieces of “canvas” plaster to be reassembled were V-shaped, inverted, and pieced together on a glass plate. The area was infused with drops of water, and rice paper was used to fill cracks. The plaster was then permeated with a 2 percent PVA solution used as a strengthening agent. Following treatment, the strengthened plaster was 1.5 to 2.0 centimeters thick.

Climate and Conditions of Storage and Restoration

Storage Climate

In Dazhao Temple, the wall painting was originally subject to significant climatic change and exposed to dust and soot. Later, in the museum, apart from periods when it was hung on display, it was always stored leaning against a wall, which exerted uneven pressure on the painting and resulted in cracking of the surface. Storage conditions have been improved: the wall painting now rests flat on a specially constructed frame, and a measure of climate control was installed in the room where it is kept. During the year, the humidity ranges between 63 and 33 percent relative humidity, and temperatures range from 25°C to -7°C. Appropriate ventilation is maintained in the summer to lower the temperature, and the humidity is adjusted during the dry months, fall and winter, increasing the air’s moisture content. The painting is protected from sunlight and UV radiation. Additional improvements need to be made because northern China is subject to significant seasonal changes, with large drops in temperature at night.

Restoration Conditions

The conservation of the Dazhao Temple wall painting, which began at the Hohhot Museum in 2001 without funds, specialists, or equipment, is considered a first in Inner Mongolia. In 2002 the museum’s meeting room was converted into a restoration space—a work platform, a setup for the painting, and restoration tools were constructed, and climate control was installed—but the primitive conditions still required constant maintenance and upgrading. The Hohhot Wall Painting Conservation Center, established in 2004, has since attracted seven specialized research technicians.

Based on the principles of applying as little treatment as possible and in sequence from smallest to largest size, conservation work on the Dazhao Temple wall painting sought to minimize the number of different materials used,

to limit their strength, to heed their compatibility, to ensure their consistency and durability, and to regulate the work approach. Just as the work of others is critiqued, our work will also be critiqued, but conservation is hardly limited to one definitive approach. Thus it is important in practice to always be responsible, willing to learn, and innovative.

Acknowledgments

The author would like to thank the Conservation Institute of the Dunhuang Academy, the Center for Conservation at the China National Institute for Cultural Property, and the National Research Institute for Cultural Properties in Nara, Japan, for their joint support and assistance. The author would also like to thank Li Zuixiong, Masaaki Sawada, Du Xiaofan, and Koezuka Takayasu for their efforts in the pigment analysis of the Dazhao Temple wall painting; Fan Zaixuan and Chen Qing for conducting treatment and restoration tests; and the Dazhao Temple wall painting conservation project team.

Notes

- 1 Liu Lingchang (1907–89) was a Chinese Art Association member and a professor at the Central Art Institute. He published works on Tang dynasty portrait painting, Chinese polychrome portrait painting techniques, tools and materials for Chinese painting, and folk wall painting.

References

- Du Xiaofan and K. Takayasu. 2000. Analysis of the Dazhao Temple wall painting at Hohhot Museum in Inner Mongolia Autonomous Region, China. Paper presented at the 18th General Conference of Japanese Cultural Properties, Nara, June.
- Fei Xin. 1928. *Xing cha sheng lan*. Guangzhou: Guo li Zhongshan da xue yu yan li shi yan jiu suo.
- Gao Lian. 1591. *Yan xian qing shang jian*. Zun sheng ba jian. [China]: Ya shang chai.
- Shen Fuwei. 1985. *Zhong xi wen hua jiao liu shi*. Zhongguo wen hua shi cong shu (Shanghai, China). Shanghai: Shanghai ren min chu ban she: Xin hua dian Shanghai fa xing suo fa xing.
- Song Yingxing. 1959. *Tian gong kai wu*. Zhongguo gu dai ke qi tu lu cong bian, no. 1. Shanghai: Zhonghua shu ju.

Pigment Analysis and Environmental Monitoring of Murals in the Tang Dynasty Huiling Mausoleum

Yang Mangmang and Zhang Yongjian

Abstract: *The Tang dynasty Huiling Mausoleum of Emperor Rang is located in Sanhe township, Pucheng county, in northwestern China's Shaanxi province. Rang had abdicated in favor of his brother, the emperor Xuanzong (r. 712–56). The tomb consists of a 19-meter-long inclined entrance shaft; seven vertical shafts; three compartments, each of which has two niches; a vaulted corridor that runs from under the third vertical shaft to the burial chamber; and the burial chamber. About 250 square meters of murals were discovered throughout the mausoleum.*

After the discovery of the first mural in 1999, scientific instruments were placed in the tomb to monitor temperature and humidity. Between March 2000 and January 2001 the mausoleum was excavated by a team from the Shaanxi Provincial Archaeology Research Institute. The principal excavation efforts were aimed at (1) monitoring relative humidity and temperature inside the tomb during excavation to provide a basis for the preservation and eventual removal, if necessary, of the wall paintings; (2) investigating the composition of the murals and the painting techniques used to create them to understand why some parts of the paintings were in good condition and others had deteriorated; and (3) sampling the murals for pigment analysis using X-ray fluorescence for comparison with other pigments used during the Tang dynasty.

The Tang dynasty Huiling Mausoleum of Emperor Rang (Hou Yangmin and Mu Weisheng 2000) is located in Sanhe township, Pucheng county, in northwestern China's Shaanxi province. Rang had abdicated in favor of his brother, the emperor Xuanzong, who reigned from 712 to 756.

Figure 1 shows the layout of the tomb, which is entered through a 19-meter-long inclined shaft. This passageway is decorated with wall paintings. There are also seven vertical

shafts into the tomb. The tomb contains three compartments, each of which has two niches. A door sealed with bricks is located under the third vertical shaft, and a vaulted corridor runs from this door to the burial chamber. About 250 square meters of murals were discovered on the walls of the inclined entrance shaft, vertical shafts, compartments, corridor, and burial chamber.

In early October 1999 tomb robbers dug a hole, measuring about 0.7 meter in diameter and 9 meters deep, at the base of vertical shaft 6 near the burial chamber. After receiving a report of this, the Shaanxi Provincial Cultural Heritage Bureau asked the Provincial Archaeology Research Institute to take an inventory of the tomb and undertake remedial measures. Salvage excavation was conducted between March 2000 and January 2001. Scientific instruments were placed throughout the mausoleum to monitor temperature and humidity, and a simple bamboo and grass shelter was built above the tomb's entrance to reduce the potential for damage from wind, rain, and sun.

Since the founding of the People's Republic of China, about twenty tombs of princes, princesses, and royal families of the Tang dynasty have been excavated. However, this is the first emperor's tomb from the peak period of the Tang dynasty that has been excavated. Therefore, the style and layout of the tomb, burial objects, and subject of the wall paintings are highly significant and provide a great deal of information on the royal family's lifestyle and burial practices.

After completion of excavation, some of the wall paintings were detached and stored in the Shaanxi Provincial Archaeology Institute. The tomb is under the custodianship of the local government and will be used as a museum open to the general public.

FIGURE 1 Plan view (top) and cross section (bottom) of the Huiling Mausoleum, tomb of the Tang dynasty emperor Rang. Between the entrance shaft and the vaulted corridor leading to the burial chamber there are seven vertical shafts (Vers. 1–7) and three compartments (Cpt. 1–3), each containing two niches (K1–K6).

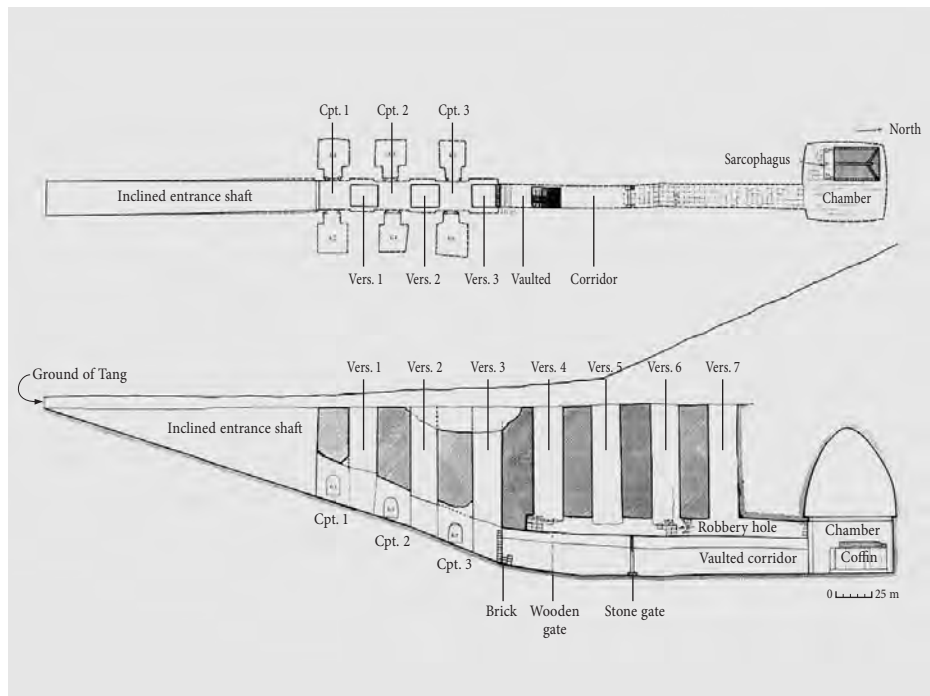

State of Preservation of the Huiling Mausoleum Murals

The best-preserved murals are on the ceiling of the vaulted corridor, followed by those in the compartments, vertical shafts, and burial chamber. The worst-preserved murals are in the entrance shaft.



FIGURE 2 Murals on either side of a niche in the east wall of the first compartment in the Huiling Mausoleum.

Corridor Murals

The murals on the ceiling of the vaulted corridor are like new, consisting of a white plaster layer on which are painted small round yellow flowers and green leaves. A few small pieces of painted plaster had fallen from the murals, and an examination of these pieces revealed that the plaster was executed with a highly refined technique; this layer is hard and with an even thickness of between 0.6 and 0.7 centimeter.

Compartment Murals

Most of the paintings on the lower parts of the compartments are portraits and are well preserved (fig. 2), although a small area has been lost, perhaps damaged when the tomb was backfilled and sealed. The upper part of the wall paintings shows flaking, detachment, and disruption problems.

Vertical Shaft Murals

The wall paintings in the vertical shafts depict mainly human figures. Most have been relatively well preserved, with only a few areas of flaking, disruption, and detachment. However, paintings on the lower part of the shaft walls were damaged. When the tomb was sealed, backfill materials such as earth and fragments of bricks were dumped from the top of shafts, and this may have caused the damage. Figure 3 shows the painting on the west wall in the first vertical shaft.

FIGURE 3 Murals on the west wall of the first vertical shaft in the Huiling Mausoleum.



FIGURE 4 Murals on the east wall of the burial chamber in the Huiling Mausoleum.



Burial Chamber Murals

The ceiling bricks of the burial chamber are exposed, and ancient looters made a hole in the southwest corner of the ceiling. The emperor's sarcophagus was positioned in the northwest corner of the burial chamber and close to the walls, and for this reason no paintings are found on the west wall and the north wall, except for an area near the east wall.

The murals on the east wall are well preserved and depict stories from the emperor's life (fig. 4). The paintings are clear, intact, colorful, and beautiful. The plaster layer has some disruption and loss problems, and the lower part of the paintings is almost completely lost.

Entrance Shaft Murals

In this passageway a blue dragon is painted on the east wall and a white tiger on the west wall. In addition to blue and white, the colors used for these paintings include red, green,

yellow, and black. The condition of the wall paintings in the entrance shaft is very poor, with disruption, detachment, and loss. The poor condition of these paintings is likely due to damage from backfill earth and brick fragments used when the tomb was intentionally sealed, as well as to the effects of farming and irrigation of the land over the shallowly buried passage. In addition, during excavation, exposure to wind and sunlight significantly affected the temperature and humidity of this part of the tomb.

Pigment Analysis

Table 1 shows the results of pigment analysis using X-ray fluorescence. The pigments used in the Huiling Mausoleum murals are the same as those normally used in Tang dynasty tombs (Zhang Qunxi 2001), grottoes, clay figures, and buildings. Because all the pigments are inorganic materials, the colors are stable.

Table 1 Results of Pigment Analysis with X-ray Fluorescence

Color	Red	Green	Black	Yellow	White
Sample Location	Neck of dragon on east wall of entrance shaft	Person's chest on north wall of burial chamber	Cloud under tiger on west wall of entrance shaft	Cloud under tiger on west wall of entrance shaft	Fallen fragment recovered from back-fill materials
Chemical Composition	HgS Vermilion	$\text{Cu}_2(\text{OH})_2\text{CO}_3$ Malachite	PbS Lead sulfide	PbO Lead oxide	$\text{Pb}_3(\text{CO}_3)_2(\text{OH})_2$ Lead white

Environmental Monitoring of the Huiling Mausoleum

Hair hygrometers and thermometers were placed at six locations throughout the mausoleum to monitor the humidity and temperature in the tomb during excavation. Data were collected hourly. Analysis of the monitoring data shows the following:

- The temperature inside the tomb in summer decreases gradually from the tomb entrance (40°C) to the lowest temperature in the corridor and burial chamber (about 13°C). The temperature inside the tomb in winter increases gradually from the tomb entrance (below 0°C) to the highest temperature in the corridor and burial chamber (about 13°C). The temperature in the corridor and the burial chamber is thus stable at 13°C year-round.
- Humidity inside the tomb also gradually increases from the entrance to the highest relative humidity at the burial chamber. Relative humidity in the corridor remains around 60 to 70 percent; inside the burial chamber, about 97 percent. Relative humidity in the entrance shaft, between the tomb entrance and the third compartment, is significantly influenced seasonally by outside conditions and by people walking in and out of the tomb. For instance, in this section relative humidity is higher in the summer and when it rains and lower in winter. Relative humidity varies between 60 and 97 percent.
- Temperature and relative humidity at the tomb entrance are significantly affected by outside conditions, which are both seasonal and diurnal. It will be a challenge to preserve the wall paintings under such a changeable environment.

Relationship of Environment to Mural Preservation

From the overall condition of the murals, it is apparent that an important relationship exists between the environment inside the Huiling Mausoleum and the state of preservation of the wall paintings. However, the typical relationship between environment and preservation does not hold for

this tomb. Normally, lower temperature and higher humidity are considered safe for murals. If this were true in the Huiling Mausoleum, then the murals in the burial chamber would be the best preserved. This is not the case. This finding agrees with the view held by conservators at Dunhuang (Wang Jinyu 1996).

The problems seen in the wall paintings in the burial chamber might also be caused by two incidents. The first is the mechanical damage from the ancient tomb robbery; the second is rainwater, which has seeped through the ancient robbery hole, damaging the wall paintings. Several key factors explain the good preservation of the murals in the corridor:

- The murals were painted on the ceiling and were thus not affected by ground moisture.
- The backfill material was pure earth, with no brick fragments. The earth was carefully moved into the corridor and piled up manually from the inside, such that it did not cause damage to the wall painting.
- In the corridor, with only limited unfilled spaces, an oxygen-deficient environment was probably established over time, and the organic materials in the paint binding medium (and possibly the plaster too) may have survived better in the absence of an oxidizing microenvironment. The most important factor for the preservation of the murals in the corridor is its stable temperature (about 13°C) and humidity (60–70%).

As mentioned, the murals in the entrance shaft are poorly preserved, and this seems related to the type of burial fill (containing brick fragments) used. All the murals in the burial chamber have a common problem: their lower part is missing. This damage is mainly due to ground moisture.

Conclusion

Our analyses of the Huiling Mausoleum murals, along with the environmental monitoring, show that an internal temperature of about 10°C and relative humidity between 60 and 70 percent provide the best preservation environment. These results also suggest that spring and autumn are the best seasons to remove the murals, should this prove necessary.

References

- Hou Yangmin and Mu Weisheng. 2000. Why was Li Xian called Emperor Rang? *Xi'an wan bao* = *Xi'an Evening News*, August 14.
- Wang Jinyu. 1996. *Exploring the Secret of Dunhuang*. Chengdu Shi: Sichuan jiao yu chu ban she.
- Zhang Qunxi. 2001. [Analysis and study on pigments of Tang tomb]. In *Tang mu bi hua yan jiu wen ji*, ed. Tianyou Zhou, Qinyan Shen, and Shanxi li shi bo wu guan, 411–19. Xi'an Shi: San qin chu ban she.

Indian Wall Paintings: Analysis of Materials and Techniques

Sekhar Chandra Set

Abstract: *In India the techniques and materials used to create wall paintings have their origins in rock paintings. This paper describes the ancient cave paintings at Ajanta, Bag, and Sittanavasal; the more recent village murals at Madhubani and wall paintings of fort palaces at Rajasthan; and the modern wall paintings found on buildings that later became Viswa Bharati University in Santiniketan. In the context of these examples, techniques and materials both in the ancient period and in the recent past are discussed.*

The principal historical source texts for Indian wall paintings date from the fifth to the sixteenth century. Although the painting methods prescribed in these texts vary, the following procedures are common to all of them: (a) preparing a fine ground for painting, (b) drawing an outline, (c) applying color with modulation, and (d) detailing. On the wall a ground consisting of two layers—rough plaster and fine plaster—is made. On the fine plaster, pigments with binding medium are applied. The description of the composition of rough plaster, pigment, and binder medium varies in the historical texts. It may be said that the texts present a reasonably accurate description of the actual painting process at some ancient Indian sites. However, a number of scholars have offered differing opinions about exact practices adopted in the ancient period. Recent wall paintings have been influenced by scientific developments. They are often painted on a surface of brick or reinforced concrete or chiseled stone tiles. Therefore, making the ground smooth by first applying a rough plaster is no longer necessary. Buon fresco and a secco painting techniques have been adopted. Pigments are synthetic, and a protective coating of diluted polyvinyl acetate (PVAC) dissolved in toluene-acetone is applied to these paintings.

The art of wall painting in India can be traced back to prehistoric times. The earliest examples of this art form can be found in caves in the hilly tracts of nine provinces of India. In particular, the Vindhya mountain range in central India provided an ideal site for prehistoric cave painting to flourish, for example, at Bhimbetka near Bhopal and at Gawalior and Adamgarh. The subject matter of these paintings included animals, birds, and human hunters, which were drawn in red ochre, with or without an outline, and painted directly on the plain rock wall. No ground was used.

Indian Wall Painting

Cave painting in India reached its height in the Buddhist religious art at the Ajanta caves, a UNESCO World Heritage Site in the state of Maharashtra; in the Buddhist religious art at the Bag caves in Madhya Pradesh; and in the Jain religious art at the Sittanavasal caves in Tamil Nadu. In later periods, we find commendable development in the techniques and form of wall paintings in the fort palaces in the state of Rajasthan, in the modern building murals of Santiniketan in West Bengal, and in the mural paintings in Madhubani in Bihar. Figure 1 shows the location of these wall painting sites. This paper discusses these wall paintings to throw light on the various painting materials and techniques adopted in the Indian context.

Origin of Painting Techniques

Wall painting techniques had their origin in the so-called *Shilpa* texts, which deal with the forms of Indian art, methods of execution, and preservation. *Shilpa* texts include *Vishnu*

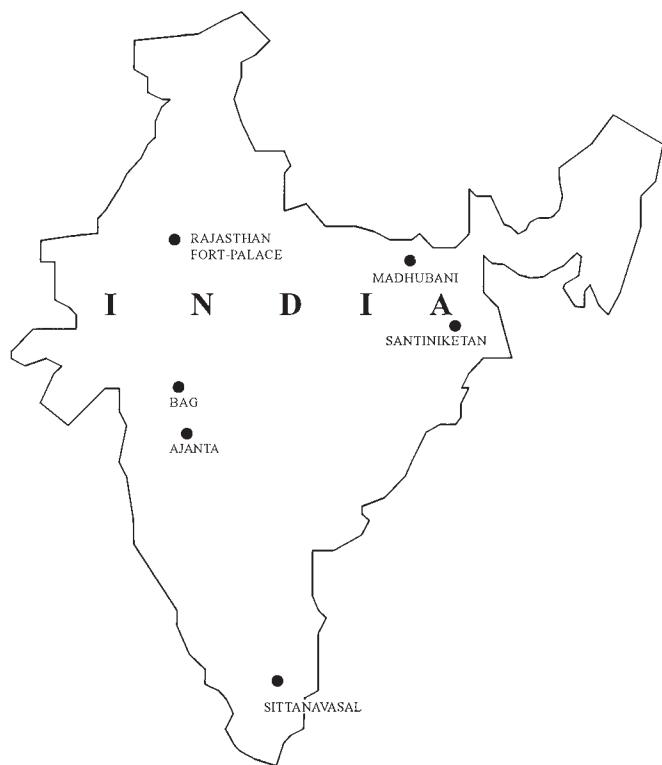

FIGURE 1 Wall painting sites in India.

Dharmottara Purana (fifth century C.E.), *Abhilashitartha Chintamani* (twelfth century), *Shilparatna* (sixteenth century), and other celebrated treatises on Indian art and related subjects. In his excellent treatise in French on the technique of Indian painting, Siri Gunasinghe (1957) dated the three texts. The question may arise about how the techniques employed in the ancient wall paintings of the Ajanta Caves (second century B.C.E.–sixth century C.E.) were inspired by *Shilpa* texts. In early times knowledge was handed down orally; it was codified in the form of *Shilpa* texts much later. Although the prescribed methods vary (variation having been advocated by the texts), the following procedures are common to all: (a) preparing a fine ground for painting, (b) drawing an outline, (c) applying color with modulation, and (d) detailing.

Components of Wall Paintings

There are five components of Indian wall paintings: carrier, ground, binder, pigments, and medium. The carrier is the support on which the ground is applied in preparation for

painting. In a cave painting, the rock wall is the carrier. In fort palace (i.e., royal palace within fortifications) mural paintings, the masonry is the carrier, and so on. Let us examine what the *Shilpa* texts say about the other components.

Ground (rough and fine plaster layers). For rough plaster, the *Vishnu Dharmottara Purana* suggests the constituents brick powder, clay, caustic lime, sesame oil, gum, and resin. The *Abhilashitartha Chintamani* advocates that rough plaster be made of a mixture of clay and animal glue. The *Shilparatna* prefers for rough plaster a mixture of limestone, shells, extracts from barks, curd, milk, and molasses. The ingredients for rough plaster were to be held together by organic materials such as gum, glue, and extracts from barks, which acted as an adhesive/binder.

The fine plaster, on which pigments are to be applied, required careful preparation. The *Vishnu Dharmottara Purana* suggests a mixture of clay, resin, and sesame oil. The *Abhilashitartha Chintamani* recommends a mixture of “naga” (most likely kaolin) and glue. The *Shilparatna* calls for a mixture of conch, oyster shells, or white clay with gum from the neem tree, or one of slaked lime and coconut water. Inorganic material such as lime or clay is the main ingredient of the fine plaster; the organic material is the adhesive/binder.

Binder. Organic material such as gum and glue extracts of bark as described above.

Pigments. The *Vishnu Dharmottara Purana* recommends pigments such as gold, silver, copper, brass, lead, tin (as leaves or as powder), mica, ivory, lac, vermilion, indigo, orpiment, and myrobalan (from the fruit of an Indian tree). The *Abhilashitartha Chintamani* prescribes conch, cinnabar, lac, red ocher, orpiment, lamp black, indigo, lapis lazuli, and gold powder. The *Shilparatna* advocates yellow ocher, orpiment, red ocher, red lead, lamp black, gold, and lac.

Medium. The *Vishnu Dharmottara Purana* and *Shilparatna* suggest that pigments be mixed with a gum solution. The *Abhilashitartha Chintamani* advocates an animal glue solution for mixing pigments.

Adherence to the *Shilpa* Texts

Let us see the extent to which the *Shilpa* texts were followed in the categories of wall paintings under discussion here.

Ajanta, Bag, and Sittanavasal Cave Paintings

The noted archaeological chemist Paramasivan analyzed samples taken from inconspicuous corners of the cave

Table 1 Wall Paintings in the Ajanta Caves (2nd century B.C.E. to 6th century C.E.)

Technique	Tempera
Carrier	Basalt cave wall
Rough Plaster	Ferruginous earth mixed with sand and organic fibers
Fine Ground	White layer of lime, kaolin, or gypsum
Pigments	White from lime, red from red ocher, yellow from yellow ocher, green from terre verte, black from lamp black
Medium	Gum or animal glue

Source: Paramasivan 1939: 25–30.

paintings at the Ajanta, Bag, and Sittanavasal sites to investigate the painting techniques. He examined cross sections of the samples to determine such characteristics as particle sizes, diffusion of materials from one layer to another, and presence of fibers. He identified the composition of the binding media and pigments through chemical analysis. On completion of his investigations, Paramasivan concluded that although the techniques enumerated in the ancient *Shilpa* texts were at variance with his scientific studies of surviving paintings, the “*Abhilasitartha Chintamani* is a fair reflection of the actual painting process in some Indian sites” (Paramasivan 1940: 95).

Table 2 Wall Paintings in the Bag Caves (early 7th century C.E.)

Technique	Tempera
Carrier	Wall of lime and sand composition
Rough Plaster	Red ferruginous earth
Fine Ground	Lime layer
Pigments	Yellow from yellow ocher, red from red ocher, green from terre verte, black from carbon black, white from lime, blue from lapis lazuli
Medium	Gum or animal glue

Source: Paramasivan 1939: 85–95.

Paramasivan’s findings for the Ajanta caves are summarized in table 1, and an example of these paintings is shown in figure 2. The painting characteristics for the Bag caves are presented in table 2, and a sample is shown in figure 3. Since the pigments used in the Ajanta and Bag wall paintings contain an organic binding medium, the painting technique is tempera (pigments dispersed in a water-miscible vehicle) and not *buon fresco* (painting on wet lime plaster) or *a secco* (painting on dried lime plaster).

Table 3 summarizes Paramasivan’s findings for the Sittanavasal cave, with a sample of the artwork shown in figure 4. The Sittanavasal paintings are *a secco*, since the pig-



FIGURE 2 Nymph from a fifth-century wall painting at Ajanta (cave 17), Maharashtra.



FIGURE 3 Bodhisattva from an early-seventh-century wall painting at Bag (cave 4), Madhya Pradesh.



FIGURE 4 Lotus lake from an early-ninth-century wall painting in the Sittanavasal cave temple, Tamil Nadu.

Table 3 Wall Paintings in the Sittanavasal Cave (8th to 9th century C.E.)

Technique	<i>Fresco secco</i>
Carrier	Rough stone
Rough Plaster	Lime and sand with minor impurities, thickness 2.5 mm
Fine Ground	Lime wash (0.5 mm thick) applied while rough plaster was still wet
Pigments	White from lime, black from wood charcoal or lamp black, yellow from yellow ocher, red from red ocher, blue from ultramarine/lapis lazuli, green from terre verte
Medium	Lime water

Source: Paramasivan 1939: 82–89.

ments were applied with lime water (lime painting on dry plaster). The lime water reacted with oxygen in the air and through carbonation was chemically converted into calcium carbonate, which is insoluble in water. The calcium carbonate enveloped the pigments and set them with the ground. No adhesive glue or gum was applied.

Rajasthan Fort Palace Painting

The wall painting technique used in the Rajasthan fort palaces is a type of *buon fresco* for which pigments are made to sink into wet lime plaster through the manual process of beating, burnishing, and polishing, which adds extra luster to the frescoes in Rajasthan. In addition, chemical carbonation acts to consolidate the pigments. The Rajasthan *buon fresco* technique is similar in all fort palace paintings. Figure 5 from the Amber Fort Palace (Jaipur) is representative of Rajasthan fort palace painting. Agarawala (1977: 60) wrote that the “Ajanta and Bag cave paintings are famous throughout the world and we are justly proud of this glorious tradition.” Table 4 summarizes the characteristics of Rajasthan fort palace wall painting.

Santiniketan Mural Paintings

Modern wall paintings adorn the buildings at Santiniketan, which later became the Viswa Bharati University. Figures 6 and 7 show examples of this artwork.

In his foreword to *The Santiniketan Murals* (Chakrabarti, Siva Kumar, and Nag 1995), K. G. Subramanyan writes:

Not so long ago a young British art critic visited Santiniketan after seeing a few black & white pho-

Table 4 Rajasthan Fort Palace Painting: Bikaner Fort, Jodhpur Fort, Udaypur Fort, Amber Fort (Jaipur) (12th to mid-19th century C.E.)

Technique	Rajasthan <i>fresco buono</i>
Carrier	Stone/brick wall
Rough Plaster	Lime and sand (sand added to prevent formation of cracks due to shrinkage of lime while drying)
Fine Ground	Two layers of fine plaster
Pigments	Red from cinnabar/red lead/red ocher, yellow from yellow ocher, blue from ultramarine, green from a mixture of blue and yellow/terre verte, brown from Indian red, white from lime, black from carbon
Medium	None

Source: Agarawala 1977: 66–70.

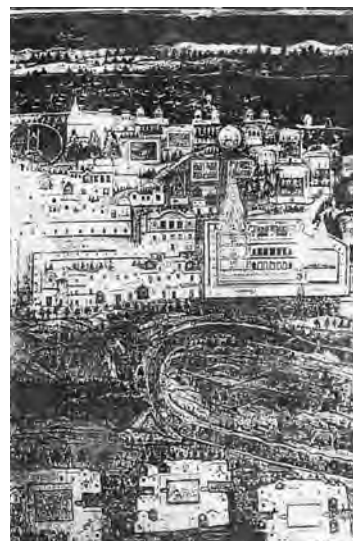

FIGURE 5 The holy city of Brindaban from an early-nineteenth-century wall painting at Amber Fort Palace, Jaipur, Rajasthan.

tographs of paintings of Benodebehari Mukherjee and Rabindranath Tagore. He found it a rewarding visit, not because everything in Santiniketan pleased him or conformed to his mental picture of the place, but because he found there what he called a living gallery of the early stages of modern Indian art. . . . When Patrick Geddes, the well-known town planner and environmentalist, visited Santiniketan at Rabindranath’s invitation in 1922, he asked Nandalal [artist Nandalal Bose] why he had not thought of covering many of the bare walls of the building with murals. . . . Nandalal never forgot this advice—he refers to it two decades later in his little book ‘Shilpa Katha.’ One really needed very little to express



FIGURE 6 Birth of the prophet Chaitanya, depicted in a 1933 building mural in Santiniketan, West Bengal.

oneself or to alter an environment. Our villagers transformed their mud huts quite radically with linear graffiti on floors and walls, using plain red and white earth, turning these modest habitations into something memorable.

In Santiniketan murals we find that the artists used the time-honored media of *buon fresco* and *a secco* on lime-surfaced walls. They also used the techniques of working on mud plaster to create wall paintings. Table 5 summarizes the characteristics of a Santiniketan mural depicting the birth of Chaitanya (a fifteenth-century prophet) painted by Nandalal Bose with the help of an elderly craftsman from

Table 5 Santiniketan Mural Painting by Nandalal Bose (early 20th century C.E.)

Technique	Rajasthan <i>fresco buono</i>
Carrier	Brick wall superstructure done in a mortar of lime brick dust
Rough Plaster	Lime and plaster
Fine Ground	Fine plaster
Pigments	Earth color of various shades like yellow ocher, red ocher, lime for white, lamp black, etc.
Medium	None

Source: Chakrabarti, Sivakumar, and Nag 1995: 1–3, 20.



FIGURE 7 Medieval saints, depicted in a 1947 building mural in Santiniketan, West Bengal.

Jaipur, named Narsingh Lal, and Nandalal's students (fig. 6). Table 6 summarizes the characteristics of a Santiniketan mural depicting medieval saints painted by Benodebehari (fig. 7). Bose used the Rajasthan *buon fresco* technique, and Benodebehari used Italian *buon fresco*.¹

Madhubani Mural Paintings

This category of wall paintings is found today in village dwellings in the Madhubani district of the state of Bihar. Villagers in Madhubani have used the tempera technique for their murals, known for their exquisite simplicity and brightness (fig. 8). These murals are traditionally painted by women. Within a broad common art form, variation occurs

Table 6 Santiniketan Mural Painting by Benodebehari (early 20th century C.E.)

Technique	Italian <i>fresco buono</i>
Carrier	Brick wall superstructure done in a mortar of lime brick dust
Rough Plaster	Lime and plaster
Fine Ground	Fine lime plaster covered with a thin coat of slaked lime
Pigments	Earth color of various shades, like yellow ocher, red ocher, lime for white, lamp black, etc.
Medium	None

Source: Chakrabarti, Sivakumar, and Nag 1995: 1–3, 27.



FIGURE 8 Krishna, depicted in a present-day village mural from Madhubani, Bihar.

in the treatment of details according to the caste of the artist. The murals are painted with bamboo twigs and rags during observance of religious and social rituals. The origin of this ritualistic domestic wall painting, which is still practiced, can be traced back to the thirteenth century, during the reign of the Hindu king Ramasinghadeva. Thakur (1981: 62) writes, “In fact Madhubani painting is a way of painting rather than a set of pictures.” Table 7 summarizes the characteristics of Madhubani mural paintings.

Discussion

The historical source texts for Indian wall paintings present a reasonably accurate description of the actual painting process found at some ancient Indian sites. However, a number of scholars have offered differing opinions about the exact techniques adopted in the ancient period; perhaps some of them commented before actually investigating the sites.

E. B. Havell, superintendent of the Calcutta Art School in the early 1900s, referred to Sir John Marshal, director-general of the Archeological Survey of India during the same period, as saying that the Ajanta and Bag cave paintings are “tempera paintings, not *fresco buono*” (Havell 1928: 8). Havell maintains, “There cannot be any doubt, however, that the true fresco process has been practiced in India for many centuries. It was used by Akbar’s painters in the decoration of Fatehpur Sikri.”

Abanindranath Tagore, an eminent Indian painter of the late nineteenth century, was engaged by Havell to paint a fresco panel at the Calcutta School of Art. Havell referred to M. Victor Goloubeff, who had begun a long-awaited photographic survey of Ajanta in 1911, as saying that “the paintings are true frescoes, though some of them have been finished or retouched by a process analogous to tempera” (8). He also referred to Vincent Smith, a historian and Indian civil servant in 1871, as saying that the Ajanta-Bag painting school is “a local development of the cosmopolitan art of the contemporary Roman Empire” (8). But he declined to accept Smith’s views.

Recent wall paintings tend to use synthetic pigments and the tempera technique. It is less time-consuming to work with this medium and technique, and consequently the painting takes less time to execute. *Buon fresco* and *a secco* are seldom found. Recent wall paintings are laid on the surface of brick, reinforced concrete, or chiseled stone tiles. Normally, the carrier is given two coats of plaster of paris, and when the final coat dries, the drawing scheme is stenciled or copied onto the wall with red or black crayon, after which a wide range of oil-based chemical colors are applied with a brush. On the painting, a protective coating of diluted polyvinyl acetate (PVAC) in toluene-acetone is applied.

Table 7 Madhubani Mural Painting (present day)

Technique	Tempera
Carrier	Clay wall of cottages with bamboo reinforcements. Walls are about 0.5 m thick and are made of clay mixed with straw and paddy (rice) husk.
Rough Plaster	First coat of paddy husk, second coat of clay with cow dung and molasses
Fine Ground	Fine clay with lime
Pigments	Earth colors of various shades, like red ocher, yellow ocher, indigo, Indian red, charcoal for black, lime for white, burnt barley seeds for black, lamp soot for black, yellow from turmeric, yellow from lime mixed with banyan leaf milk, orange from flower, green from leaves, black from burning straw mixed with goat milk, white from powdered rice mixed with water.
Medium	Vegetable gum or glue

Source: Thakur 1981: 63–64.

Acknowledgments

I wish to acknowledge Rabindranath Poyra, superintendent of Library Services, Central Library of Calcutta University at Calcutta, for his help in locating old journals; and Satyabrata Ghoshal, librarian of Rabindra Bharati University at Calcutta, for permitting me to conduct literature surveys there.

Notes

- 1 In Italian *buon fresco*, pigments are diluted in water and brushed on the wet ground of fine lime plaster, which absorbs the colors. When the lime plaster dries, calcium carbonate forms on the outer surface, enveloping the pigments and protecting them from weathering. With this technique, the colors are thin and transparent. In Rajasthan *buon fresco*, pigments are brushed on the ground and made to sink into the fine lime plaster through the manual process of beating, burnishing, and polishing. With this technique, the colors are thick and opaque. The burnishing and polishing give them extra luster.

References

- Agarawala, R. A. 1977. *Marwar Murals*. Delhi: Agam Prakashan.
- Chakrabarti, J., R. Sivakumar, and A. K. Nag. 1995. *The Santiniketan Murals*. Calcutta: Seagull Books.
- Gunasinghe, S. 1957. *La technique de la peinture indienne d'après les textes du silpa*. Paris: Presses Universitaires de France.
- Havell, E. B. 1928. Indian mural painting. In *Indian Sculpture and Painting Illustrated by Typical Masterpieces, with an Explanation of Their Motives and Ideals*, 2nd ed., 155–82. London: J. Murray.
- Paramasivan, S. 1939a. The mural paintings in the cave temple at Sittannavasal: An investigation into the method. *Technical Studies in the Field of the Fine Arts* 8 (1): 82–89.
- . 1939b. Technique of the painting process in the cave temples of Ajanta. *Annual Report of the Archaeological Department of His Exalted Highness the Nizam's Dominions* (1936–37): 25–30.
- . 1939c. The wall paintings in the Bagh caves: An investigation into their methods. *Proceedings of the Indian Academy of Science, Section A* 10 (2): 85–95. www.ias.ac.in/j_archive/proca/10/voliocontents.html.
- . 1940. Indian wall paintings. *Journal of the Madras University* 12 (1): 95–128.
- Thakur, U. 1981. *Madhubani Painting*. Delhi: Abhinav Publications.

Conservation of Mural Paintings Transferred from a Royal Mausoleum of the Western Han Dynasty at Shiyuan, Henan Province

Tie Fude

Abstract: Most transferred wall paintings have shown damage. The structure of wall paintings is complicated, and the causes of damage are many and varied. So far we have not achieved a good understanding of the causes of deterioration or had examples of successful treatment. This study analyzes an early Western Han dynasty wall painting and makes a preliminary attempt to understand the causes. It investigates the materials, types of damages, preservation environment, and previous conservation treatments of the wall painting and aims to develop proper techniques and materials for preserving them. The mural painting under consideration, which depicts four deities (Blue Dragon, White Tiger, Scarlet Bird, and Black Turtle) among clouds, was found in a tomb in the mausoleum of a king of the Liang Kingdom of the early Western Han dynasty (second century B.C.E.), located at Shiyuan in Mangdang Mountain in Henan province. In 1992 it was lifted and transferred onto a poly board strengthened with cotton fiber. In 1999 deformation, warping, and cracking appeared on the surface of the painting. A conservation project was undertaken.

Damage to a wall painting usually comes from the very act of its transfer, due to the materials of the painting itself and their incompatibility with protective materials and to an unfavorable environment. The wall painting Four Deities (5.14 by 3.27 meters) is a quintessential example. It was transferred from a tomb in the mausoleum compound of a king of the Liang Kingdom during the early Western Han dynasty (second century B.C.E.) that is located at Shiyuan, Henan province. The painting depicts deities such as Blue Dragon, White Tiger, Scarlet Bird, and Black Turtle, as well as magical herbs and flying clouds (fig. 1). This study analyzes the

materials of the painting, the types of damage, the environment in which the painting is preserved, and the history of treatment. The goal was to find out the causes of the damage, in the hope of finding the proper techniques, materials, and methods for its long-term protection.

Background of and Damage to the Wall Painting

History of Interventions

Water accumulation in the tomb in which the Four Deities was originally found caused high humidity. An investigation prior to the removal of the wall painting indicated a temperature of 16°C and a relative humidity of 96 to 99 percent. The painting itself had a moisture content of 3.2 to 3.5 percent, sometimes as high as 14.8 percent. Because of these unfavorable conditions inside the tomb, the painting was removed in 1992. X-ray diffraction (XRD) analysis in the same year showed that the plaster layer was made of mixed clay and sand with a high content of calcium carbonate but without any fiber. The pigments are vermilion, mica, and malachite. Before the removal process, polyvinyl



FIGURE 1 The Four Deities wall painting.

acetate (PVAc) emulsion was used to reinforce the flaking fragments. The painting was cut into five pieces (3.27 by 1.13 meters), and the surface was reinforced with 5 percent polyvinyl butyral (PVB) solution, gauze, and glue. The cut segments were secured onto an epoxy backing strengthened with cotton gauze and the backing fixed onto a wooden frame (Chen Jinliang 2001: 317–25).

Exhibition Environment

The wall painting was displayed in the Henan Province Museum in 1998. The room temperature and humidity were $21 \pm 3^\circ\text{C}$ and $60 \pm 5\%$ relative humidity in summer and $23 \pm 3^\circ\text{C}$ and $33 \pm 5\%$ relative humidity in winter. The painting was displayed in an unsealed glass-fronted wooden case lit by lamps totaling 240 watts. The temperature inside the case was stable, but the relative humidity varied seasonally, from 26 to 65 percent.

Types of Damage

The painting was deformed and cracked and the paint layer warped. Fissures occurred in the upper left and bottom right corners. The painting surface also bent following the distortion of the wooden frame. The wooden frame and epoxy backing were severely deformed. In addition, the securing fixtures had started to loosen.

Materials and Structure of the Wall Painting

Analysis of the material and structure of a painting plays a vital role in preserving and restoring it. Samples from the painting were analyzed using SEM-EDX (Hitachi S3000N) and XRD (Rigaku Dmax/2200). The main constituents of the plaster are calcium carbonate and silica; the original reinforcing agent had not penetrated deep into the plaster, which resulted in accumulation of polyvinyl butyral on the surface

(fig. 2); the polyvinyl acetate coating on the back of the painting is generally even, although the porosity is greater in some areas; the cotton fiber in the epoxy backing is not evenly distributed, although the epoxy itself is stable and well bound to the plaster layer; pores in the epoxy, which result from the evaporation of the solvent in the epoxy (fig. 3), are concentrated on the surface where the backing meets the plaster. In cross section the plaster layer is one-half the total thickness (5 mm). These data help us not only to understand the causes of the deteriorations but also to provide the foundation for the search for the right materials to use in restoring it.

3D Laser Digital Analysis of the Wall Painting

Preliminary investigations showed that the major types of damage to the wall painting were deformation caused by warping, cracking, and scaling. Because the surface of the painting had already distorted, conventional two-dimensional recording methods were not applicable (Schmid 2000: 21–28). With a 3D Minolta VIVID900 laser scanner, we documented the deformation of the painting and formulated a 3D model. The whole painting was scanned 88 times line by line horizontally and vertically, and nine key points were scanned 36 times. The scanning results were processed using the Polyworks software made by InnovMetric from Canada.

Figures 4 through 6 present the scanning results. This qualitative and quantitative mapping, recording, and analysis documents the condition of the painting and thus provides a database for future restoration work.

Mechanical Study of Deformation

Study of the deformation of the wall painting began with an analysis of the characteristics of the materials and their implications. In the past decades little research, either

FIGURE 2 Electronic SEM image of PVB.

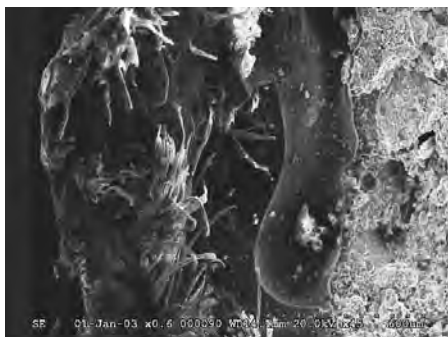

FIGURE 3 Electronic SEM image of pores in epoxy.

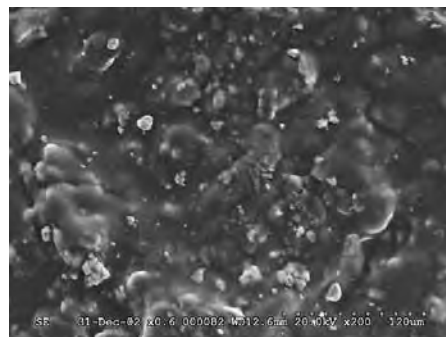
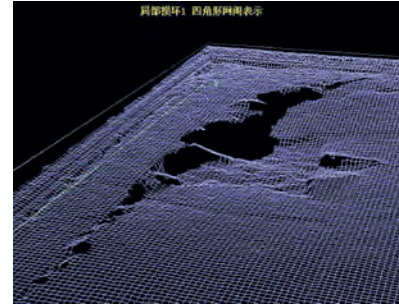

FIGURE 4
Deformation.



FIGURE 5 Net imaging of hole 1.



domestic or international, has been done on the materials of the backing of wall paintings, and even less research has been done on the supporting frame (Hedley 1975: 1–17; Berger 1984: 7–9; Colville, Kilpatrick, and Mecklenburg 1982: 165–70; Karpowicz 1989: 67–74). Our study is a preliminary effort in this direction. Starting with a scientific analysis of the original and present conditions of the wall painting and its materials, we analyzed the deformation using the Ansys Software in the hope of determining the causes.

Based on the original and preservation materials mentioned above and their thickness, we established a model of the materials of the painting layer, as follows:

When the heat factor is considered, the relationship between the stress and the change caused by the stress is $[\epsilon_L]^{[h]} = [s][\sigma_L] + [\alpha_L] \Delta T$ (algorithm 1);

When the humidity factor is considered, the relationship between the stress and the change caused by the stress is $[\epsilon_L]^{[m]} = [s][\sigma_L] + [\alpha_L] \Delta M$ (algorithm 2);

When the heat and humidity and exterior load are combined, the algorithm becomes

$$\begin{Bmatrix} \epsilon_L \\ \epsilon_T \\ \gamma_{LT} \end{Bmatrix} = \begin{Bmatrix} S_{11} & S_{12} & 0 & \sigma_L \\ S_{21} & S_{22} & 0 & \sigma_T \\ 0 & 0 & S_{66} & L_T \end{Bmatrix} + \begin{Bmatrix} \alpha_L \\ \alpha_T \\ 0 \end{Bmatrix} \Delta T + \begin{Bmatrix} \beta_L \\ \beta_T \\ 0 \end{Bmatrix} \Delta M \text{ (algorithm 3)}$$

Using Ansys Software and algorithm 3 and the aforementioned data, we calculated the bending of the wall painting. The result is that the maximum displacement of the 300-millimeter-long wooden frame is 9 millimeters; when all the factors are considered, the maximum displacement along the lines where the wall painting was cut is 15 millimeters, and the minimum displacement is 3 millimeters. This

FIGURE 6 3D image of a crack.

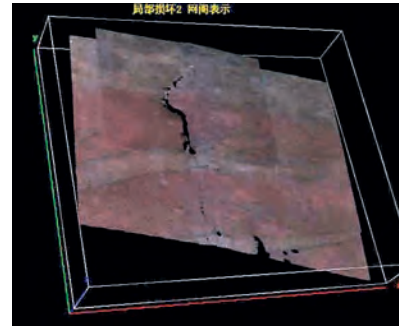

result is in general agreement with the measurements taken from the wall painting itself. The result of the calculation is shown in figure 7.

The Ansys analysis indicates that the causes for the bending of the wall painting are as follows: (a) the materials of the painting layer and the backing are not evenly distributed and the humidity-caused swelling produces bulging in some areas of the painting layer; (b) the setting of the epoxy binding the wooden frame and the backing caused the frame to bend backward; (c) because of the epoxy layer, the front and back sides of the wooden frame expanded unevenly, which also contributed to its bending; (d) the unstable humidity of

FIGURE 7 Calculated stress distribution over the frame.

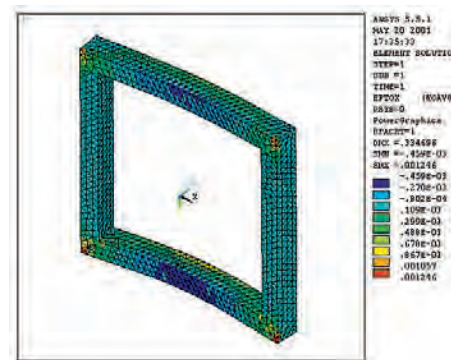

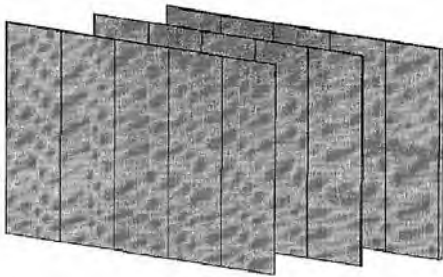

FIGURE 8 The restored frame. From left to right: painting, elastic layer, porous aluminum.

the environment in which the painting was stored gave rise to its deformation.

It follows that the wooden frame that caused the deformation of the painting needed to be removed and replaced with light and rigid materials. We chose a honeycomb aluminum board as frame and added an elastic layer to absorb remaining stress from the epoxy layer, as shown schematically in figure 8.

Preservation and Restoration of the Wall Painting

Surface Reinforcing Materials

The PVB material used for reinforcement during the transfer process was still in good condition. For the sake of consistency and compatibility, we continued to use PVB to preserve the surface of the wall painting. We used PVAc emulsion to reinforce the flaking areas. Where the plaster layer was lost, we injected a mixture of polyvinyl alcohol (PVA) emulsion to stabilize the warped painting layer.

Coating

Through experiments and simulations we chose 2 percent PVA solution in water as the adhesive and two layers of Chinese rice paper (*xuanzhi*) as the coating. This choice was made in consideration of the minimum interference principle on the one hand and of the epoxy resin on the back of the painting on the other. In addition, the rice paper is easy to remove after the final treatment.

Removal of the Wooden Frame and the Epoxy Layer

After testing, we chose to use a thread saw (conventionally used in surgery) to detach the deformed wooden frame,

because it causes the least impact to the painting. Sawing was conducted 2 millimeters from the back of the epoxy layer, and the remaining wood was removed manually using a carving tool. Epoxy ridges were removed by means of an electric drill.

Intermediate Layer

An intermediate layer between the backing of the painting and the honeycomb aluminum was necessary to facilitate any future restoration. This layer, if made of elastic material, helps to relieve or eliminate stress from the epoxy layer. After many experiments and evaluations, a material designated by the manufacturer QH-B6 was chosen for the intermediate layer, since it has a stress resistance of 1 megapascal (MPa) and an elasticity of about 75 percent. The mini-pores in this material are all closed and even in diameter and thickness of wall, forming a net structure. The evenness of the microscopic elements increases the stability and resistance to stress and impact.

Removable Supports

The wall painting is 17 square meters in dimension and 3.24 meters in height, which demands rigidity of the frame materials. The honeycomb aluminum panel is used in China's aviation industry and has the strength and stiffness to satisfy these requirements.

Adhesive

The adhesive used in the restoration of the painting must have good adhesion and binding to the epoxy and the aluminum. To absorb the stress from the two layers, the adhesive must have a high degree of elasticity and resiliency. During operations, we found that it took an individual segment at least one hour for the adhesive to set. Since it was difficult to secure the position of the three layers, the primary adhesive force had to have sufficient strength; the adhesive also needed sufficient solid content so as to prevent voids on setting. Based on these requirements, we tested a polyurethane adhesive, a chlorobutyl adhesive, and an acrylic acid adhesive. We found that the polyurethane adhesive, with its tensile strength of 0.5 to 0.7 MPa, was the best for the purpose.

Static Mechanical Property of the Support System

The painting layer (including plaster) is 4 millimeters thick; the epoxy layer is 1 millimeter thick, and the weight of the two layers is 12 kilograms per square meter. This weight exerts a shear force of 0.32 kilopascal (kPa) to the materials of

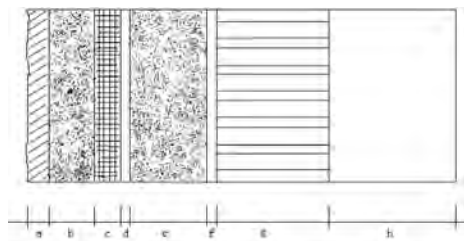

FIGURE 9 Section view of the wall painting after restoration: (a) pigment; (b) plaster; (c) epoxy; (d) adhesive; (e) intermediate layer; (f) adhesive; (g) honeycomb aluminum panel; (h) hard backing frame.

the layer underneath. The remaining stress from the back of the epoxy layer is no more than 12 kilograms per square meter of the painting layer, or 0.118 kPa ($1 \text{ kg/cm}^2 = 98.1 \text{ kPa}$). When the painting is placed vertically during exhibition, the painting and backing layers are static, without any exterior force. What they receive is the cutting shear (0.32 kPa) coming from the weight of these layers and the remaining stress of the epoxy. Both force and stress are much lower than the weight that the backing materials can hold.

Mechanical Distribution after Restoration

The wall painting after restoration is shown schematically in figure 9. The mechanical distribution of the whole is

Stress load 0.5 kPa < Adhesive 0.5 MPa
< Intermediate layer 1 MPa
< Porous aluminum 3 MPa
< Aluminum frame

and the strength increases gradually from the painting layer toward the frame. This mechanical structure stabilizes the wall painting.

Conclusion

Based on a preliminary analysis of the causes of deterioration of the painting and the techniques and materials, we carried out a series of restoration operations, including removal of the original supporting frame and replacement with a new frame. The project was approved by the China National Cultural Heritage Bureau in 2003 and was awarded a second-grade prize for scientific innovation by the bureau.

References

- Berger, G. A. 1984. The new stress tests on canvas paintings and some of their implications on the preservation of paintings. In *Preprints: ICOM Committee for Conservation, 7th Triennial Meeting, Copenhagen, 10–14 September 1984*, ed. D. de Froment, 84.2.7–84.2.9. Paris: International Council of Museums in association with the J. Paul Getty Trust.
- Chen Jinliang. 2001. [Report on removing the wall painting from a Han tomb at Shiyuan]. In *Mangdang Shan Xi Han Liang wang mu di = Prince of the State of Liang's Mausoleums of the Western Han at Mount Mangdang*, ed. Yan Genqi, 317–25. Beijing: Wen wu shu ban she.
- Colville, J., W. Kilpatrick, and M. M. Mecklenburg. 1982. A finite element analysis of multi-layered orthotropic membranes with application to oil paintings on fabric. In *Science and Technology in the Service of Conservation: Preprints of the Contributions to the Washington Congress, 3–9 September 1982*, ed. G. Thomson and N. S. Brommelle, 146–50. London: International Institute for Conservation of Historic and Artistic Works.
- Hedley, G. A. 1975. Some empirical determinations of the strain distribution in stretched canvases. In *Preprints: ICOM Committee for Conservation, 4th Triennial Meeting, Venice, 13–16 October 1975*, 75114-1 to 75114-17. Paris: International Council of Museums.
- Karpowicz, A. 1989. In-plane deformation of films of size on paintings in the glass transition region. *Studies in Conservation* 34 (2): 67–74.
- Schmid, W. 2000. *GraDoc: Graphic Documentation System in Mural Painting Conservation: Research Seminar, Rome, 16–20 November 1999*. Rome: ICCROM.

PART EIGHT

Consolidation and Stabilization



Condition, Conservation, and Reinforcement of the Yumen Pass and Hecang Earthen Ruins near Dunhuang

Wang Xudong, Li Zuixiong, and Zhang Lu

Abstract: *The ancient Yumen (Jade Gate) Pass, located about 90 kilometers northwest of Dunhuang, on the bank of the Shule River in the Gobi Desert, was established in the Western Han dynasty and was a vital gateway on the northern route of the Silk Road. The Hecang Fortress, 11 kilometers northeast of the Jade Gate, also dates from the Western Han dynasty. Both sites, constructed of earth, have been preserved in the arid environment, but after more than two thousand years of exposure they are severely deteriorated. Conservation and consolidation were urgently needed. Investigation of the condition of the sites, together with physical, chemical, and mechanical tests of their earthen material, revealed two categories of problems: weathering of walls and foundations and cracking and collapse of walls. Potassium silicate solution and antiweathering techniques were used to consolidate the most severely weathered walls, and foundations were buttressed with adobe bricks. Cracked walls were reinforced by grouting and bolting, and collapsed walls were restored with rammed earth. These measures are in line with conservation principles for site preservation and are an important experiment in the conservation of earthen structures, affording successful examples for the preservation of similar structures in the region.*

The ruin of Yumen Pass, also called Xiaofangpan Fortress, is located on the Shule River in the Gobi Desert approximately 90 kilometers northwest of Dunhuang (fig. 1). Built during the Western Han dynasty, it served as a strategic point on the northern Silk Road and played an important role in the development of the Western Regions (Compiling Committee 1996). The extant structure is a square fortress with an area of approximately 702 square meters (26.4 m by 26.6 m). The



FIGURE 1 Condition of the Yumen Pass before consolidation.

walls, approximately 10 meters high, were built of rammed earth (fig. 2).

Hecang Fortress, also known as Big Fangpan Fortress, is on a tableland on the south bank of the Shule River, 11 kilometers northeast of the Yumen Pass (fig. 3). It too was built during the Western Han dynasty, and it was rebuilt during the Western Jin dynasty. Li Zhengyu (1996: 302–3) believes that it was originally the Chang'an granary for the Dunhuang prefecture in the Han and Jin periods. It is in the form of a square with collapsed walls. In the north there is a 2-meter-high natural platform extending from east to west, on which a rectangular granary (132 m by 17 m) was constructed with three spacious rooms. All rooms face south. The roof collapsed long ago, and it is impossible to know what it was like. The southern wall and a partitioning wall have mostly collapsed. The other three walls and the other partitioning walls

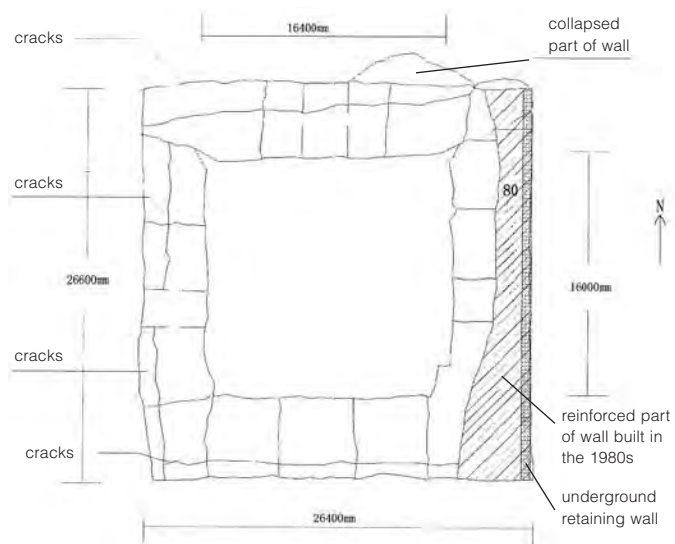

FIGURE 2 Layout of the Yumen Pass.

have survived. These walls have an average height of 6 meters and a thickness of 1.5 meters. In the upper and lower parts of the walls there are two rows of evenly distributed triangular ventilating holes. Of the walls encircling the granary, only the eastern, northern, and western ones have their foundations partially preserved. Of the four corner towers, only the southwestern one is extant; the other three have only their foundations preserved.

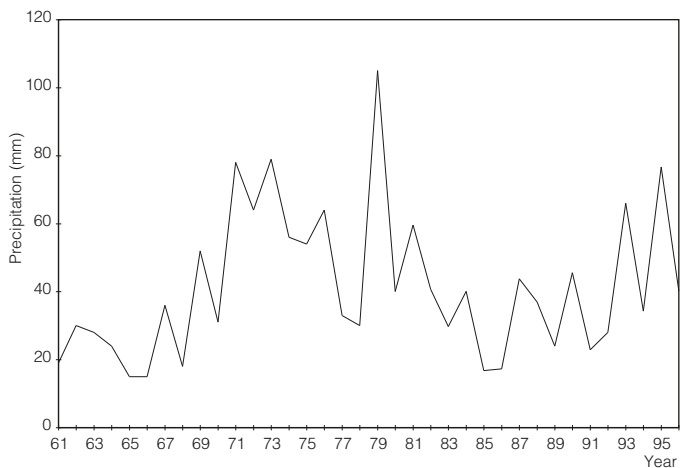

FIGURE 4 Yearly precipitation in the Dunhuang area.



FIGURE 3 Condition of the Hecang Fortress before consolidation.

Earthen structures of the Western Han dynasty are now rare. They bear significant value for an understanding of the history, agriculture, communication, military affairs, and architecture of the Western Han and Western Jin dynasties.

The Yumen Pass and Hecang Fortress were able to survive due to the arid climate, but recent investigation showed that immediate conservation was needed to prevent further deterioration. With this vision, we conducted intramural and field tests (Li Zuixiong, Zhang H., and Wang Xudong 1995; Su Bomin, Li Zuixiong, and Hu Z. 2000; Li Zuixiong, Wang Xudong, and Tian L. 1997; Li Zuixiong and Wang Xudong 1997). These tests were evaluated and approved by the State Administration of Cultural Heritage before implementation.

Local Climate

Precipitation

Temperature and rainfall are two factors that affect the earthen structures. As shown in figure 4, annual precipitation in the Dunhuang area between 1961 and 1996 was characterized by extreme instability. Meteorological records kept at the Dunhuang station show that 1979 and 1956 mark the two extremes, 105.5 millimeters and 6.4 millimeters, respectively. The annual precipitation is in general on the increase. The evaporation volume, however, is stable and falls between 2,200 and 2,700 millimeters.

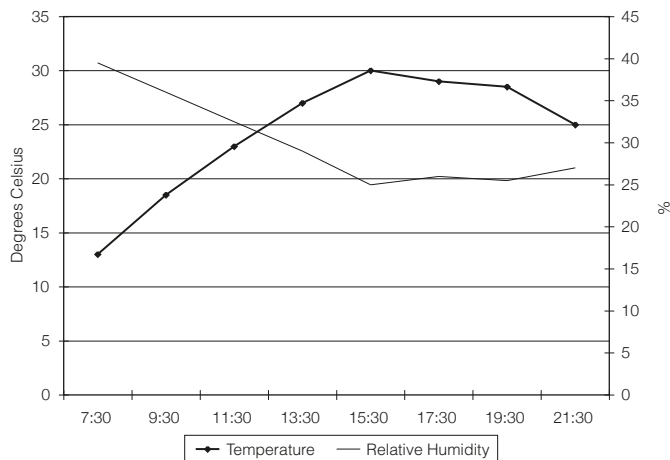

FIGURE 5 Humidity variations on August 27 at the Hecang Fortress.

Temperature and Humidity

A preliminary recording of temperature and humidity was undertaken from August 21 to September 25, 2000, at the Hecang Fortress during our consolidation operations. Data were recorded every two hours between 7:30 and 21:30 from a thermohydrograph placed in the shade. Although these data do not cover twenty-four hours, they reflect the regularities of temperature and humidity fluctuations during this period and served as useful information for the conservation work.

During this period, daily mean temperature showed a declining trend, while the daily mean humidity rose slightly. For example, as shown in figure 5, on August 27 temperature rose from the lowest point at 7:30 to a high between 13:30 and 15:30 and thereafter began to drop. The relative humidity declined from the highest value at 7:30 to the lowest point between 13:30 and 15:30 and thereafter began a slow rise. The daily temperature fluctuation was large, with a maximum of 19.5°C, a minimum of 10.5°C, and an average difference of 14.96°C. The daily humidity change was also considerable. In sum, temperature at the Hecang Fortress was relatively high, with a wide fluctuation range, and humidity was low.

The best temperature range for potassium silicate (PS) solution infiltration is between 18°C and 25°C, and the acceptable working temperature range is 15 to 30°C (Li Zhengyu 1996). Adjustment can be made on-site if needed, so that the optimal effect of PS reinforcement can be attained.

Properties of the Earth

Yumen Pass

Table 1 gives the physical properties of the earth from the Yumen Pass, and table 2 shows the analysis of the soluble salts. The soluble salts are mainly chloride and sulfate—NaCl, CaSO₄, MgSO₄, with pH values of 7.39–8.50—and the earth is alkaline. The total salt content is higher in the upper

Table 1 Physicodynamic Properties of the Earth from Yumen Pass

	Middle, North Wall West	Upper Part, North Wall West	Lower Part, North Wall West	Bottom, North Wall West	Massive Sample
Moisture content (%)	1.3	1.1	1.7	1.6	2.9
Dry density (g/cm ³)					1.87
Porosity ratio					0.480
Saturation (%)					16.3
Porosity rate (%)					32.4
Soil grain gravity	2.70	2.69	2.69	2.69	2.69
Liquid limit (%)	25.6	20.4	22.8	24.3	23.6
Plastic limit (%)	16.2	13.8	16.1	16.8	16.5
Plasticity index	9.4	6.6	6.7	7.5	7.1
Particle size	0.25–0.075 mm	16.5%	13.5%		8.5%
	0.075–0.005 mm		72.5%	72.5%	77.5%
	0.005 mm		11.0%	14.0%	14.0%

Table 2 Soluble Salts in the Earth from Yumen Pass

Sample Location		Wt%			
		Bottom, North Wall West	Lower Part, North Wall West	Middle, North Wall West	Upper Part, North Wall West
CO ₃ ²⁻ HCO ₃ ⁻ Cl ⁻ SO ₄ ²⁻ Ca ²⁺ Mg ²⁺ Na ⁺ + K ⁺			0.001		
		0.018	0.028	0.022	0.019
		4.861	0.166	0.098	0.020
		1.195	0.130	0.205	0.454
		0.026	0.009	0.061	0.139
		0.005	0.001	0.004	0.005
		3.767	0.185	0.101	0.075
pH		7.39	8.50	7.98	8.04
Total salt content (Wt%)		9.995	0.519	0.477	0.735

Table 3 Physical Indices of the Soil at Hecang Fortress Ruins

Sample Location		Physical Indices					
		Pedestal, SW Corner	Pedestal, NW Corner	Pedestal, NE Corner	Pedestal, SE Corner	West Wall	North Wall
Density (g/cm ³)		1.838	1.915	1.643	1.923	1.897	1.762
Porosity ratio		0.476	0.411	0.658	0.472	0.426	0.554
Porosity rate (%)		32.18	29.08	39.60	31.75	29.76	35.46
Particle gravity		2.71	2.70	2.72	2.71	2.70	2.73
Liquid limit (%)		25.2	21.4	32.3	23.1	22.3	32.2
Plastic limit (%)		14.1	14.6	18.7	11.2	14.0	16.6
Plasticity index		11.1	6.8	13.6	11.9	8.3	15.6
Particle size	0.25–0.075 mm	21.23	23.93	4.85	61.47	27.93	28.58
	0.075–0.005 mm	66.33	72.81	82.65	31.81	68.74	60.65
	0.005 mm	12.44	3.26	12.50	6.72	3.33	10.77
	d ₁₀	0.0031	0.0282	0.0036	0.0086	0.0273	0.0046
	d ₃₀	0.0212	0.039	0.0175	0.0276	0.0333	0.0243
	d ₆₀	0.055	0.049	0.0535	0.113	0.0416	0.0605
Soil classification		silt	silt	silt	silt	silt	silt

part of the walls than in the middle and extremely high at the bottom. This is the result of a high rate of evaporation and capillarity from the ground.

Hecang Fortress

Table 3 shows the physical properties of the earth from the Hecang Fortress. It can be seen that the density of the earth samples is irregular, which is a characteristic of artificial earth structure. Due to the different extents

of weathering, uneven particle sizes, and partial calcareous nodules, the samples vary widely in density and porosity. The greater the dry density, the less the porosity and the more solid the earth.

Because of the partial calcareous nodules or sand lentils, as well as evident differences in the particle size, the difference in the speed of disintegration on wetting varied greatly: from rapid (17.46 g/min) to slow (less than 0.1 g/min). On the whole, nonuniform engineering performance

might result from uneven soil density so that the strength and stability might be adversely affected.

Chief Problems of the Yumen Pass and Hecang Fortress

Weathering of Walls and Foundations

There are two types of weathering: chemical and physical. Chemical weathering results from enrichment of soluble salts in the wall foundations. Because of precipitation and capillarity, soluble salts dissolve, crystallize, and dissolve again and finally lead to the destruction of cohesive forces and the erosion of wall and foundations. Physical weathering is erosion by wind and rain. It is windy in the Dunhuang area throughout the year, causing the formation of honeycomb on the surface of walls. Although precipitation is generally low, when heavy it contributes significantly to erosion, as it softens and disintegrates the earth. High evaporation following heavy rain quickly dries and turns the softened wall surface into scalelike crusts, which fall off under the combined forces of wind and rain.

Cracking and Collapse of Walls

The weathering described above bites into wall foundations and changes the stress distribution of the wall body, which causes cracks parallel to the wall surface. Cracks are normally 2 to 5 centimeters wide, but they can be up to 10 centimeters wide. This is worsened by fissures left by the ramming operations when the walls were built. So when it rains or an earthquake occurs, the walls easily collapse. Collapse may

also happen along the fissures between ramming layers, as the fissures grow under natural forces.

Conservation

Foundation Reinforcement

Where wall foundations were eroded, the surface was cleaned of friable earth. PS solution was infiltrated into the area to consolidate it; thereafter, adobe bricks with a dry density of no less than 1.75 grams per cubic centimeter were laid to support the foundation. Surface treatment was done for visual compatibility. Figures 6 and 7 show an area of the Hecang Fortress before and after reinforcement.

Surface Consolidation

PS solution with a lower concentration (generally 2 to 3 percent) was used to harden the surface of walls exposed to intense wind and rain. The solution was injected into the target areas repeatedly. In the case of scaling wall surface, PS-C solution was used to bind the scales to the wall body. After drying, mud with PS solution was applied so as to restore the original appearance of the wall.

Potassium silicate was the primary material for reinforcing the walls and foundations of the Hecang Fortress. After the softened areas were cleaned, three PS solutions of varying concentrations were sprayed on them at intervals of a week to ensure complete infiltration: 2 to 3 percent solution the first time, 5 percent solution the second time, and 7 percent solution the third time. Ten percent PS solution with added earth was applied to the softer and more porous



FIGURE 6 Hecang Fortress before consolidation.



FIGURE 7 Hecang Fortress after consolidation.

areas to cement large grains of clay. Finally, mud from local earth was used to restore the original look.

Multiple applications of low-concentration PS solutions are important in the treatment strategy for conserving earthen structures (Li Zuixiong, Zhang H., and Wang Xudong 1995). It maximizes deep infiltration and minimizes the concentration gradient so that the treated surface will not be too strong to hold to the wall. So far this strategy has been effective.

Reinforcement of Cracked Walls

Anchor Rod Reinforcement at Yumen Pass. Unlike the traditional method of support, which aims to hold back the collapsing rock or earth, an anchor rod strengthens the body of rock or earthen structure itself, effectively preventing it from deforming and collapsing. It is also advantageous in that it does not jeopardize the appearance of a treated structure.

The anchor rods used are hot-rolled iron bars, and the binding materials are cement mortar; we have also studied binding materials suitable for anchoring and selected PS-F, PS-C, and others (Li Zuixiong, Wang Xudong, and Tian L. 1997). Anchor washers, made of iron plates, were used to hold the target area (Liang J. 1999). They were secured only with bolts and caps onto the anchor rods (fig. 8).

This anchoring system was used to reinforce the northern, western, and southern walls of the Yumen Fortress. Holes were typically drilled at an interval of 1.5 meters vertically and 1.0 meter horizontally. Their depths varied but in general exceeded 1.0 meter. Lower rows of holes were drilled at an angle of 10 to 15 degrees; the upper rows of holes were drilled at a smaller angle or horizontally. All the holes were 50 millimeters in diameter. In order to reduce vibration, drilling was done manually. Rods were 45-millimeter-diameter iron pipes with wooden sticks inside and corrosion-proof mate-

rials coating the outside. PS solution was poured into the holes to pretreat the walls of the holes, PS and clay solution or PS-F liquid was poured into them, and finally the anchor rods were inserted. A total of 81, 100, 84, 29, and 8 rods were installed in the northern, western, and southern walls and the western and northern gates, respectively. The lengths of rods were determined on the spot and varied from 0.50 meter to 4.50 meters.

Grouting and Draining. Extensive cracks had developed in the walls and gates of the Yumen Pass, and if left untreated rainwater would seep into the cracks, weaken the walls, and eventually lead to collapse. Cracks were filled with earth, and PS-F or PS-C solution was added so as to consolidate them. Also, drainage was installed to remove rainwater.

Reinforcement of Collapsed Walls

North Wall of the Yumen Pass. The north wall of the Yumen Pass had partially collapsed. To secure the extant portion, a new rammed wall was built in collapsed areas and integrated with the old wall with “soil nails” and reinforced earth. Soil nailing is a technique that consolidates an earthen surface by nailing steel netting into the surface and coating the nails and nets with cement (Cheng Liangkui, Zhang Z., and Yang Z. 1994). This technique has been widely used in quarrying works (Zeng Xianming, Huang J., and Wang Z. 2000), but its use in cultural property conservation is rare.

These techniques were employed in reinforcing the collapsed northern wall of the Yumen Pass. Local earth was also used for making new rammed earth walls. Earth was crushed and soaked before being mixed with lime. This mixed earth was then used for forming new wall. Layers ~18 centimeters thick were laid and rammed manually until reduced to 15 centimeters. Reinforcing iron frames, 300 by 300 millimeters, were placed both horizontally and vertically in the

FIGURE 8 Section view of anchor rod structure.

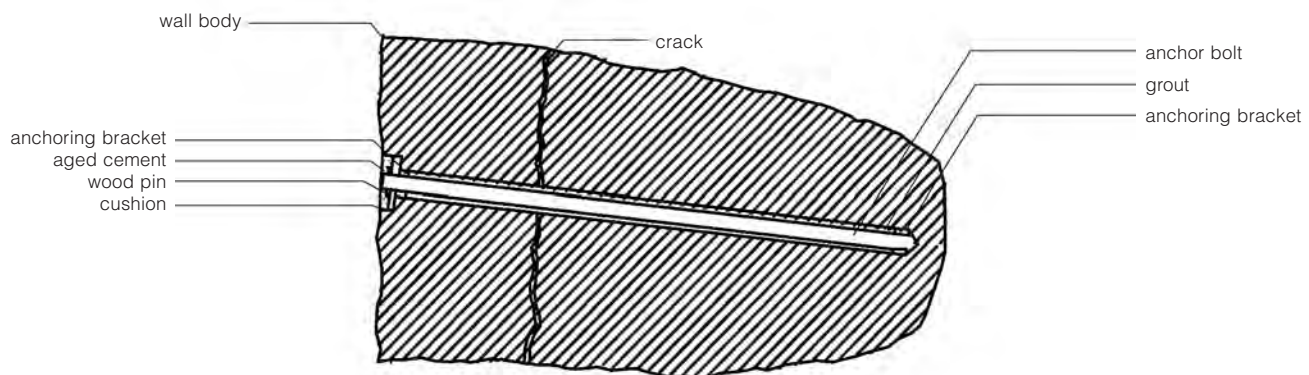

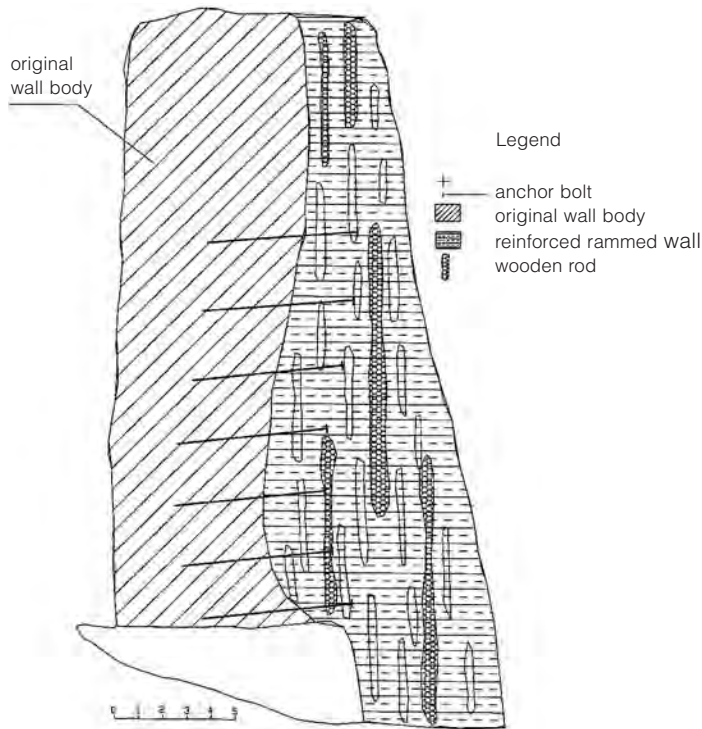

FIGURE 9 Soil mass consolidated with *Achnatherum* stalks on the northern wall.

rammed earth. *Achnatherum* stalks were laid crosswise on each layer to increase the bonding strength of the new wall. PS-tempered clay was used to fill the fissure between the new and old walls (fig. 9).

East Wall of the Yumen Pass. A brick wall foundation (25 m long, 0.5 m wide, and 40 cm deep) was laid along the footing of the reinforcing wall built in the 1980s to prevent the wall from sliding. The original wall was consolidated with PS solution. Along the original wall, a



FIGURE 10 Reinforced outer section of the northern wall.

40~500-centimeter-wide reinforcing wall was built to buttress the original wall.

Conclusion

The Yumen Pass and the Hecang Fortress have survived in the arid environment in northwestern China. Over the past two thousand years, they have suffered cracking, collapse, and wind erosion. Reinforcement work was undertaken to preserve their high historic, scientific, and archaeological values. After a detailed investigation, anchoring techniques were used to consolidate the weathered walls with potassium silicate materials. Soil nailing and reinforced soil techniques were also used under collapsing walls, and mud bricks were inserted to support walls and the platform (fig. 10). These measures guarantee the preservation of these unique earthen structures while complying with the principles of cultural property conservation. It is also a valuable trial of rock and soil reinforcement techniques in conservation and will provide examples for conserving earthen structures in northwestern China.

References

- Cheng Liangkui, Zhang Z., and Yang Z. 1994. *Practical Techniques of Rock and Soil Reinforcement*. Beijing: Seismology Publishers.
- Compiling Committee for the Annals of Dunhuang City. 1996. *Annals of Dunhuang City*. Beijing: Xinhua Publishing House.
- Liang J., ed. 1999. *Manual of Anchoring and Injection Techniques*. Beijing: China Electric Power Publishers.
- Li Zhengyu. 1996. *A New Perspective of Dunhuang History and Geography*. Taipei: Xinwenfeng Publishing.
- Li Zuixiong. 1996. Issues of stability and strength in reinforcing earthen and rock cultural sites. *Dunhuang Studies* 3: 96–106.
- Li Zuixiong and Wang Xudong. 1997. Progress in conservation and reinforcement of ancient earthen structures. *Dunhuang Studies* 4: 167–72.
- Li Zuixiong, Wang Xudong, and Tian L. 1997. Experimental reinforcement of earthen structures in ancient Jiaohe city. *Dunhuang Studies* 3: 171–81.
- Li Zuixiong, Zhang H., and Wang Xudong. 1995. Reinforcement of ancient earthen structures. *Dunhuang Studies* 3: 1–18.
- Su Bomin, Li Zuixiong, and Hu Z. 2000. A preliminary study of potassium silicate and its application in earth structure conservation. *Dunhuang Studies* 1: 30–35.
- Zeng Xianming, Huang J., and Wang Z. 2000. *Manual of Soil Peg Support and Construction*. Beijing: China Architecture Publishers.

Research and Application Methods for Comprehensive Control of Wind-Borne Sand at the Mogao Grottoes

Wang Wanfu, Wang Tao, Zhang Weimin, Li Zuixiong, Wang Xudong, Zhang Guobing, Qiu Fei, and Du Mingyuan

Abstract: *On the plateau behind the Mogao Grottoes to the west lie megadunes. For centuries wind-borne sand has cascaded over the cliff face, burying the entrances to the caves and accumulating on the elevated walkways of the upper tiers. Some 2,000 cubic meters of sand were removed annually by Dunhuang Academy staff, until the early 1990s, when the 3.7-kilometer-long open-knit wood fence and a windbreak of local xeric plants reduced the quantity of sand by 60 percent. This paper reports on further developments, including new techniques such as straw half buried in a grid pattern, a surface layer of gravel, expansion of the drip-irrigated vegetation fence, and chemical consolidation of sand on the cliff top. Through this multifunctional system that includes engineering, biological, and chemical measures, the objective is to develop comprehensive control of windblown sand.*

The Mogao Grottoes are located in an extremely arid region. On the one hand, dryness and rare rainfall are natural environmental conditions that have favored preservation of the wall paintings in the cave temples. On the other hand, the Mingsha dunes on the plateau above the Mogao Grottoes are an abundant sand source that threatens the site. In recent decades experts have focused on the control of blown sand, and many ideas have been put forth and experiments carried out. The work reported here builds principally on earlier research, testing, and implementation at Mogao on the control of windblown sand by a 3.7-kilometer-long synthetic textile wind fence; the use of desert-adapted plants; and chemical consolidation of sand. This work was published in the proceedings of the International Conference on the Conservation of Grotto Sites, held at Mogao in October 1993 (see Ling Yuquan et

al. 1997; Lin et al. 1997; Li Zuixiong, Agnew, and Lin 1997). Engineering protection was discussed by Lin et al. (1997); Qu Jianjun et al. (2001); and Xue Xian, Zhang Weimin, and Wang Tao (2000). A vegetation windbreak and its effects were studied by Wang Wanfu et al. (2004). Meanwhile, the urgency of setting up a comprehensive protection system was discussed by Zhu Junfeng and Zhu Zhenda (1999); Wang Wanfu, Zhang Weimin, and Li Yunhe (2000); Qu Jianjun et al. (2001); Zhang Weimin et al. (2000); and Wang Wenfu et al. (2004).

Through analysis of the effectiveness of drip-irrigated vegetation windbreaks, engineering measures including half-buried straw “checkerboard” barriers, gravel mulch, and nylon fences on the plateau above the Mogao Grottoes, an attempt was made, as described here, to set up a rational, scientifically designed, comprehensive protective system to control windblown sand.

Blown-Sand Environment

The Mingsha sand dunes comprise a 60- to 170-meter-high megadune that is the main source of sand threatening the Mogao Grottoes. Through photographs taken during the same season in 1972 and 1985, using a terrain model, the dune topography was mapped at 1:1000 scale. Qu Jianjun et al. (1997) reported that small dunes at the edge of Mingsha migrate from southwest to northeast. The annual movement of small dunes is 3 to 9 centimeters, with an average of 6 centimeters. The dunes are essentially stable, and small movements at the edges represent little threat to the site. However, the real threats to the site are windblown sand accumulation, wind erosion, and dust storms.

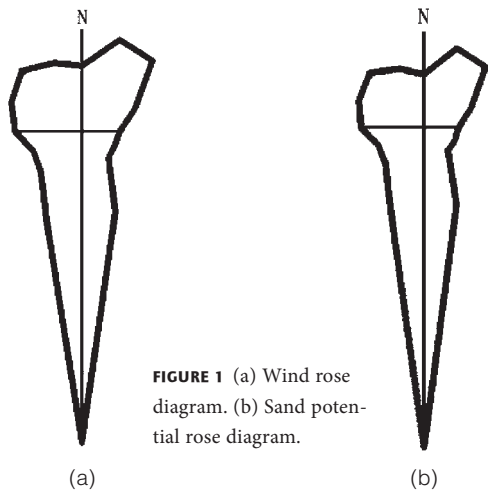

FIGURE 1 (a) Wind rose diagram. (b) Sand potential rose diagram.

Wind data from the meteorological station on the cliff top collected during the period 1990 to 2002 are represented on the wind rose (fig. 1a) and sand-drift potential rose (fig. 1b). Wind rose and sand rose diagrams are based on a polar coordinate system to present their frequency at specific directions. The most common rose diagram has 16 azimuth angles. The length of ray at each azimuth angle is proportionate to the frequency of wind at that specific direction. A sand rose diagram may be different from the associated wind rose diagram because a wind speed of less than 5 ms^{-1} does not carry sand. The drift rose is drawn by a computer program and is based on the quantities of sand collected by a specially designed sand collector with twelve receptacles distributed at 30° to each other. Sand movement results mainly from the westerly and southerly winds, which blow 31 and 30 percent of the time, respectively; the easterly wind blows 15 percent of the time but is weak. The surface material on the plateau comprises gravel, sandy gravel, an area of shifting sand and small dunes, and the megadune, the last being the westernmost. The key to controlling blown sand from the cliff edge is to stabilize and thereby decrease the sand coming from the Mingsha megadune, as described below.

Measures for Controlling Windblown Sand

Straw “Checkerboard” Barriers

The shifting sand is located in an area of small dunes and flat sand sheets at the front edge of the Mingsha megadune. A windbreak fence of open-knit nylon and half-buried straw checkerboard barriers (fig. 2) are the control measures here. The main function of the straw barriers planted in the sand in a square checkerboard grid is to stabilize the shift-



FIGURE 2 Half-buried straw checkerboard barriers.

ing sand by changing the roughness of the surface. This decreases the impact threshold velocity, hence the rate of sand transport, and transport from the sand dune field is reduced. This also creates suitable conditions for growth of vegetation. The friction as a result of the straw checkerboard barriers in the areas of shifting sand and small dunes increases thirty to forty times, and the roughness of the surface also greatly increases.

Nylon Wind Fence

Figure 3 shows the plan of the open-knit nylon fence, and figure 4 shows sand accumulation. Over seven years a

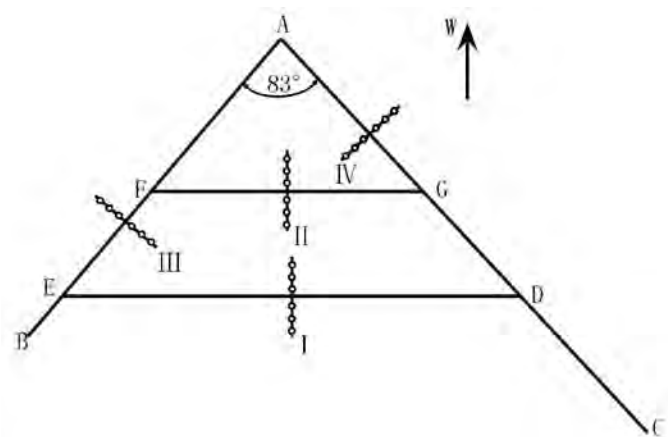

FIGURE 3 Schematic drawing of wind fence and sand depth monitoring sticks along lines I–IV.



FIGURE 4 Sand accumulation around the wind fence.

total volume of 23,000 cubic meters of sand accumulated around the fences. Sand accumulation on the AC segment accounted for 13,000 cubic meters, which shows that the northwest direction is the main source under the control of the westerly winds. Sand accumulation on the AB segment to the southwest accounted for 5,400 cubic meters, which shows that the southwest is another sand source. Sand accumulations on the DE and FG segments were 3,600 and 1,700 cubic meters, respectively, showing sand mainly originating in situ.

Section IV (see fig. 5a) shows that the profiles of sand accumulation under the control of the northwesterly winds vary seasonally and annually. Sand accumulates especially during the windy season, March to July. Sand accumulation in 1992 and 2002 was similar, reaching 30 centimeters.

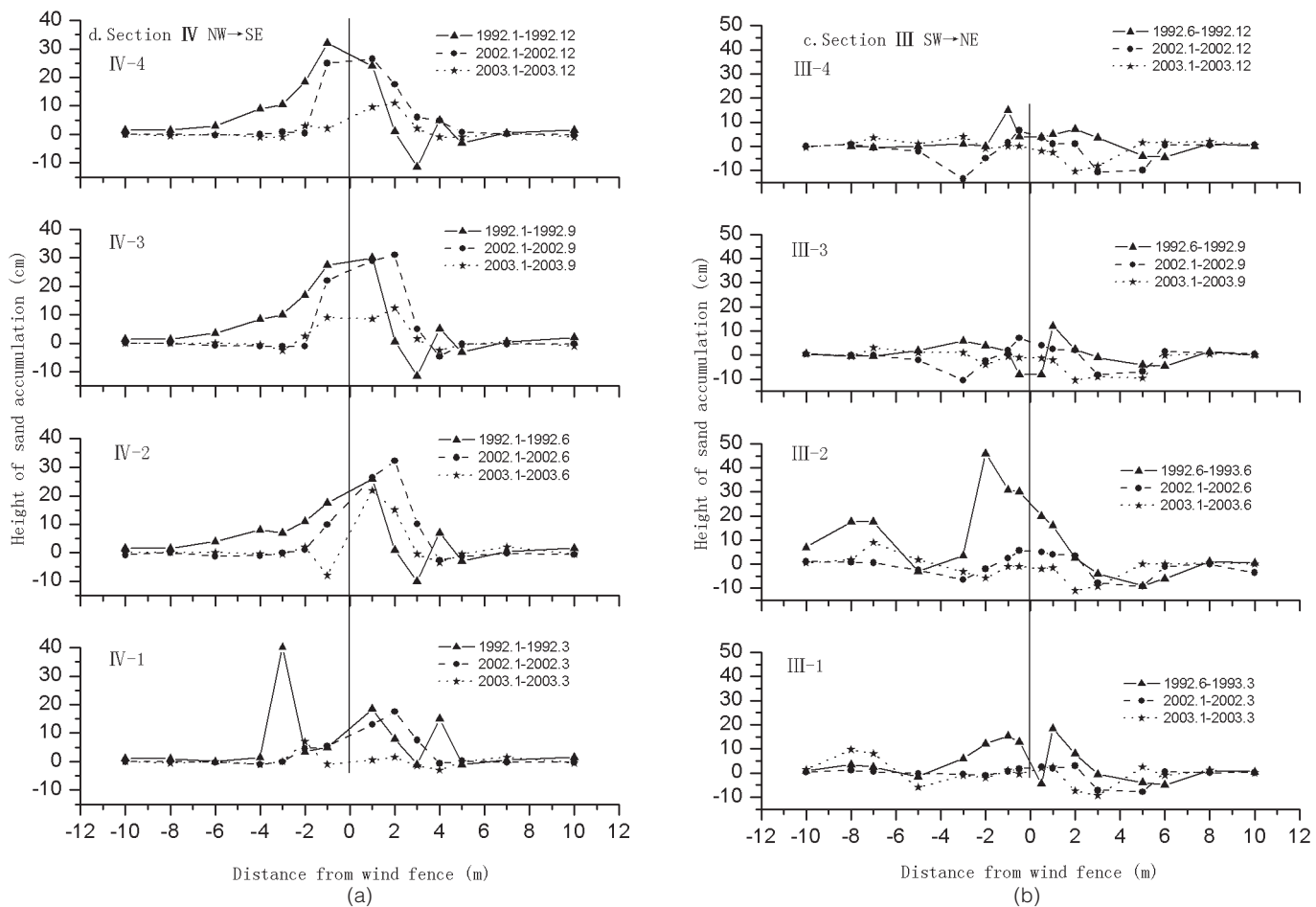

FIGURE 5 (a) Section IV sand accumulation on a quarterly basis for the years 1992, 2002, and 2003, showing the upwind and downwind depths. (b) Section III showing sand depths under the influence of the southwesterly wind.

However, after the sand source was further controlled in 2002, the amount of sand around the fence decreased greatly, to about 10 centimeters annually.

Section III (fig. 5b) shows the comparable profiles of sand accumulation for the southwesterly winds. The processes of sand accumulation are most obvious and reach 25 centimeters during the March–July windy season. Wind erosion also occurs, reaching a depth of 10 centimeters.

Large amounts of sand from the Mingsha megadune are arrested by the nylon fences. Southerly winds caused by local air circulation have a higher frequency and longer duration, but the volume of the sand transported is much lower than that carried by westerly winds, and the transport rate decreases gradually from the Mingsha megadune to the top of the grottoes.

Gravel Layer

Gravel placed on sand (a gravel “mulch”) is effectively unerodable and increases the roughness and dissipates wind energy. This results in a decrease in the wind velocity and an increase in shear stress of the airflow near the surface, thus decreasing wind erosion. Gravel straw stubble and increasing cover of vegetation windbreaks effectively restrain wind erosion and are effective approaches to control blown sand. But there is some disagreement on coverage.

Based on wind tunnel experiments (Dong Zhibao, Qu Jianjun, and Liu Xian 2001), regardless of the size of the pebbles on a natural gobi surface as long as they cover about 40 to 50 percent of the area, there is no potential sand movement. But according to a study of sand control (Xue Xian, Zhang Weimin, and Li Yunhe 2000), in order to completely eliminate sand erosion of the ground surface at the plateau above the grottoes, more than 65 percent of the area should be covered with pebbles. Field observations showed that sand coming from the Mingsha megadune can be transported to the gravel area when wind velocity is less than 10 ms^{-1} . Because the particle size roughness of gobi is ten times greater than that of dune sand, the sand threshold velocity also will increase. Sand from the Mingsha dune fills spaces between gravel particles, thus causing local sand accumulation. When the wind velocity is more than 10 ms^{-1} , the energy of the blown sand stream stimulates sand saltation. This results in erosion of the gobi.

The reason that sand accumulation and small dunes do not form is the gobi’s rough surface, which decreases the capacity of sand transportation and serves as a site for the temporary arresting of sand. Because the gobi on the top

of the grottoes contains a certain percentage of sand, the sand transport rate over this surface is low. There is little energy loss due to elastic collision between sand grains and gravel particles; hence the grains in the gobi sand stream reach much greater heights, the sand flux decrease is slower, and the mean velocity of the grains is higher than that in a typical sandy desert. In addition, the sand grains can fully acquire the energy from the airflow at different heights so that the gobi sand stream is always in an unsaturated state as regards the carrying capacity of the wind. Field observations show that the sand transport rate from between 0 and 20 centimeters in height is more than 93 percent when flow velocity reaches 10.4 ms^{-1} .

Vegetation Windbreak

Figure 6 shows the vegetation windbreak on the plateau, in front of the Mingsha megadune. The airflow pattern near the shrub zone, which is 1.5 meters in average height and 50 percent permeation through the shrubs, is similar to that at the nylon wind fence, which has similar height and weave density. Based on the energy distribution, the flow pattern can be described as decelerating wind velocity that occurs before the shrub zone, decreasing speed in the shrub zone, recovering speed coming out of the shrub zone, and accelerating velocity that occurs far beyond the shrub zone. The shrub zone can obviously reduce wind speed, and a double line of shrub zones can reduce wind speed significantly. Wind speed downwind, at a distance of about twenty to thirty times the



FIGURE 6 Vegetation wind fence and drip irrigation.

Table 1 Rates of Sand Transport Upwind and Behind the Vegetation Windbreaks

Height (cm)	Upwind	2 m behind	2 m behind
	Sand Dune	First Wind Break	Second Wind break
Sand Transport Rates ($\times 10^{-4}$ g/cm $^{-2}$ · min $^{-1}$)			
0~2	23.84	0.35	0.04
2~4	19.82	0.22	0.02
4~6	7.82	0.41	0.02
6~8	3.71	0.10	0.22
8~10	1.88	0.06	0.03
10~12	0.98	0.06	0.02
12~14	0.52	0.11	0.02
14~16	0.37	0.04	0.02
16~18	0.22	0.10	0.02
1~20	0.19	0.09	0.01
0~20	59.35	1.54	0.43

height of the shrubs, was 40 to 70 percent of that at 30 meters upwind of the shrub zone.

Table 1 shows the observed sand transport rates upwind and behind the vegetation wind breaks. Under a northwest wind speed of 9.8 ms^{-1} , the sand transport rates (0~20 cm high) 30 meters upwind of the shrub belt, 2 meters behind the first vegetation fence, and 2 meters behind the second are 59.35×10^{-4} , 1.54×10^{-4} , and $0.43 \times 10^{-4} \text{ g/cm}^{-2} \cdot \text{min}^{-1}$, respectively. Sand transport rates at 2 meters behind each shrub shelter belt are 1/38 and 1/138 less than the sand transport rates 30 meters upwind, showing the effectiveness of the system.

Comprehensive Effects of Sand Control

Through comparative determination of the quantities of sand accumulation on the walkways in front of caves 152, 208, 256, 454, 404, and 457, it was found that the sand deposits markedly decreased when the nylon fences in the gobi area were set up in October 1991 (fig. 7). During the first year, the amount of sand deposited on the walkways decreased by about 39 to 83 percent, and sand control thereafter improved yearly. Sand accumulation on the walkways increased significantly in 2000, however, for two reasons. First, sand had piled up about 1.8 meters at both sides of the fence by 1999, which reduced its sand-blocking effect. Second, sand cleaning along the northwest and southeast wind of the fence in 1997 disturbed the stable gobi surface and contributed to sand accumulation on the walkway. While still an experimental system under development, the nylon fence, vegetation barrier, and chemical stabilization of sand set up in 2003 at the cliff edge produced a decrease of sand deposition in front of the grottoes of approximately 94 to 98 percent compared to the period before the 1990s.

Conclusion

In order to significantly reduce windblown sand accumulation at the site, a multifunctional protective system (fig. 8), including engineering, biological, and chemical measures, was established over a period of some twelve years. The strategy was to reduce sand coming from the Mingsha megadune and stabilize the in situ sand on the gobi surface between the dune and the grottoes. Under the control of multidirectional winds, some sand is arrested by the gravel and some is transported by the gobi sand stream. The latter may be a threat to the Mogao Grottoes in that the sand is transported by salta-

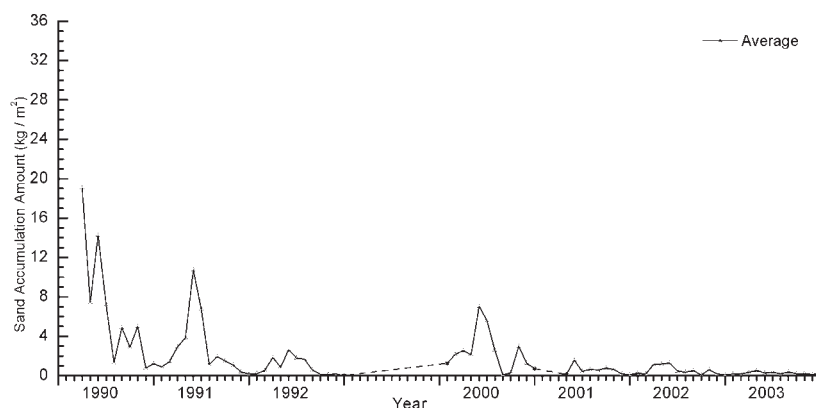
FIGURE 7 Monthly and yearly average sand accumulation in front of the caves.

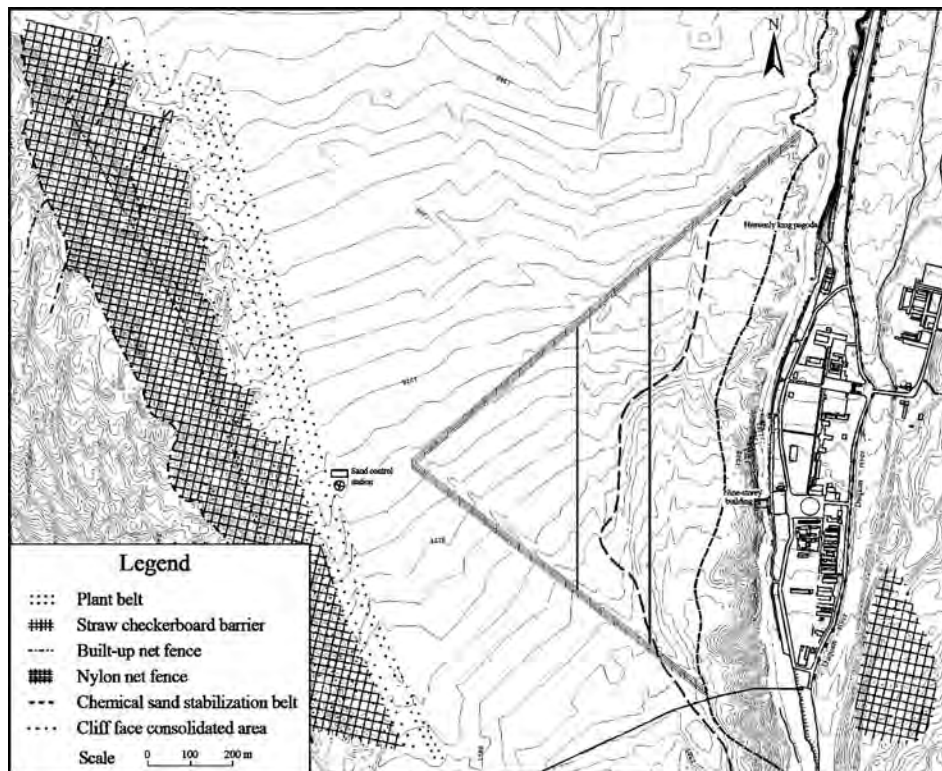

FIGURE 8 Plan of the Mogao Grottoes site showing the multifunctional sand control system.

tion. The grit gobi surface inhibits sand transport. The combination of the upright sand-block fences, half-buried straw checkerboard barriers, drip-irrigated vegetation fences, and gravel “mulch” has so far proven an effective way to protect the Mogao Grottoes from the hazards of windblown sand.

Acknowledgments

The project was supported by a National Key Basic Research Special Foundation Grant (No. G2000048705), the National Relics Bureau Project of Science and Technology for Relics Conservation (No. 9907), and the Planting Plan of Buddhist Benefaction for Dunhuang, Hong Kong. The authors are grateful to Fan Jinshi, director of the Dunhuang Academy, and Neville Agnew and Po-Ming Lin of the Getty Conservation Institute for their support.

References

- Dong Zhibao, Qu Jianjun, and Liu Xian. 2001. [Experimental research on the resistant coefficient on the ground surface of the Gobi Desert.] [*Science in China*] 31: 953–58 (in Chinese).
- Li Zuixiong, N. Agnew, and P.-M. Lin. 1997. Chemical consolidation of conglomerate and sand at the Mogao Grottoes. In *Conservation of Ancient Sites on the Silk Road: Proceedings of an International Conference on the Conservation of Grotto Sites*, ed. N. Agnew, 194–212. Los Angeles: Getty Conservation Institute.
- Lin, P.-M., N. Agnew, Li Yunhe, and Wang Wanfu. 1997. Desert-adapted plants for control of windblown sand. In *Conservation of Ancient Sites on the Silk Road: Proceedings of the International Conference on the Conservation of Grotto Sites, Mogao Grottoes at Dunhuang, October 1993*, ed. Neville Agnew, 227–34. Los Angeles: Getty Conservation Institute.
- Ling Yuquan, Qu Jianjun, Fan Jinshi, and Li Yunhe. 1997. Research into the control of damage by windblown sand at the Mogao Grottoes. In *Conservation of Ancient Sites on the Silk Road: Proceedings of the International Conference on the Conservation of Grotto Sites, Mogao Grottoes at Dunhuang, October 1993*, ed. Neville Agnew, 213–26. Los Angeles: Getty Conservation Institute.
- Ling Yuquan, Qu Jianjun, Fan Jinshi, Li Yunhe, N. Agnew, and P.-M. Lin. 1996. [Analysis of the effectiveness of sand control on the plateau above the Mogao Grottoes]. *Zhongguo sha mo = Journal of Desert Research* 16 (1): 13–18.
- Qu Jianjun, Huang Ning, Dong Guangrong, and Zhang Weimin. 2001. [The role and significance of the Gobi Desert pavement in

- controlling sand movement on the cliff top near the Dunhuang Mogao Grottoes]. *Journal of Arid Environments* 48 (3): 357-71.
- Wang Wanfu, Li Zuixiong, Liu Xianwan, and Zheng Caixia. 2004. [The results of shrub belts on sand control at the top of the Mogao Grottoes]. *Zhongguo sha mo = Journal of Desert Research* 24 (3): 306-12.
- Wang Wanfu, Zhang Weimin, and Li Yunhe. 2000. [A study on the impact of blown sand and its control at the Mogao Grottoes]. *Dunhuang Research* 63 (1): 42-48.
- Xue Xian, Zhang Weimin, and Wang Tao. 2000. [The results of wind tunnel experiments on sand control with gravel and field monitoring: A case study at the Mogao Grottoes]. *Acta Geographica Sinica = Journal of Geographical Sciences* 55 (3): 375-83.
- Zhang Weimin, Wang Tao, Xue Xian, Wang Wanfu, Guo Yingsheng, and Liu Jinxiang. 2000. [Study of a comprehensive system to control windblown sand at the Mogao Grottoes]. *Zhongguo sha mo = Journal of Desert Research* 20: 409-14.
- Zhu Junfeng and Zhu Zhenda. 1999. *Zhongguo sha mo hua fang zhi*. Beijing: Zhongguo lin ye zhu ban she.

Restoration and Consolidation of Historic Earthen Structures: The Upper and Middle Temple Complexes at the Mogao Grottoes

Sun Yihua, Wang Wanfu, and Fu Qingyuan

Abstract: *The adjacent Upper and Middle Temple complexes are rare surviving examples of earthen buildings at the Mogao Grottoes. According to the inscribed plaque on the entry gate of the Middle Temple, it was built in 1772 C.E. (during the Qing dynasty, in the thirty-seventh year of Emperor Qianlong's reign). At Dunhuang, an arid region, most of the buildings were made of earth. After some two hundred years, the walls of the temples had deteriorated; this has been especially rapid over the past twenty years as the buildings were left unoccupied and not maintained.*

The principle followed for conserving and restoring the temple buildings specifies that after restoration the structures should retain as much of the original fabric as possible. The conservation plan comprised three parts: (1) collapsed and nonextant structures were to be reconstructed based on their foundations and knowledge of the surrounding buildings; (2) for partially collapsed buildings, the collapsed areas were to be reconstructed and the rest of the buildings restored and stabilized; and (3) for the relatively intact buildings, only the lower parts of walls were to be restored and strengthened.

During restoration, an invisible, impermeable layer was added to the footings of the buildings. Based on information gained from historical traces and remains, windows and doors were restored to their 1944 condition. The restoration was completed in June 2003, and today the temples display their historic appearance. Through this project, a way of conserving deteriorated earthen buildings was developed. Both the approach and the techniques are new and in compliance with the China Principles.

As an important World Heritage Site on the Silk Road, the Mogao Grottoes, with their exquisite mural art and statuary,

have received considerable attention. In addition to the grottoes, many buildings, primarily monasteries and temples, were originally constructed over a period of more than a thousand years, beginning in about the fourth century C.E. According to the historical record, there were many ancient monasteries and temples at Mogao Grottoes. Today, only a few temples from the Qing dynasty survive at the site. These include the Upper and Middle Temples (so called because of their location in relation to the grottoes along the cliff face) and two earthen buildings only 50 meters from the grottoes. Each temple is a complex of buildings. Together, the temples contain twenty-five buildings with a total of eighty-one bays (a Chinese ancient building unit). After being exposed to the elements for more than two hundred years, the earthen walls of the Upper and Middle Temples have weathered and deteriorated. This situation has worsened over the past twenty years when the buildings were unoccupied and not maintained (fig. 1).

The deteriorated temples were eyesores, and their significance and conservation needs attracted the interest of colleagues from the Getty Conservation Institute and the Australia Heritage Commission. Experts from both institutions visited the temples in 2000 and proposed a treatment plan based on the China Principles (Agnew and Demas 2004) to stabilize the buildings and restore them to their original appearance (fig. 2).

The structures themselves are not architecturally significant, so why should we conserve them now? Because they housed the first state-sponsored conservation and research institute, the National Dunhuang Art Research Institute. Established in 1944, this institute later became the Dunhuang Academy. The buildings were used as offices,



FIGURE 1 Deteriorated north wall of a building in the Upper Temple before restoration.

work areas, and staff quarters until the late 1970s. Thus the temples are historic structures owned by the state, and they signify the transformation of commonplace constructions to commemorative ones.

Values Assessment and Investigation

The Upper and Middle Temples are two small building complexes next to each other, typical of the local mud-brick, flat-roofed style. There are several very old elms inside the courtyards. The gate of the Upper Temple is inscribed with the words *Lei Yin Temple*, but this inscription and a couplet on both sides of the doorframe are scarcely visible.

A wooden plaque from the gate of the Middle Temple, bearing the words *Lei Yin Chan Lin* (the name of the temple complex), is dated to the thirty-seventh year of Emperor Qianlong (1772). The words on the back of the plaque explain that the temple was rebuilt with collected alms; therefore, it must have been built before the year 1772. The plaque is now housed in the Dunhuang Academy's cultural artifacts storage area.

The two temple complexes are similar in scale and layout. The building walls were made of mud brick, without sill wall bricks. All north-facing rooms and side rooms were constructed with flat roofs, while small post-and-beam structures were used for the main rooms.

When the newly formed National Dunhuang Art Research Institute moved into the temples in 1944, the rooms were altered to accommodate staff (some fourteen families in all) and to serve as offices. When the institute moved to a new building and became the Dunhuang Academy, the



FIGURE 2 The north wall shown in figure 1 after restoration.

abandoned temples were seriously damaged by weathering, and parts of the temples collapsed. Branches of the old elms also endangered the roofs. Leaking water rotted the wooden supports under the roofs. Piles of rubbish that had accumulated at the foot of the buildings over the years led to rotting of the column bases. The mud plaster fell from the walls, exposing the mud bricks and subjecting the walls to salt efflorescence and cracking.

Prior to conservation, only seven buildings were in good condition—those that served as the residence of Chang Shuhong, first director of the National Dunhuang Art Research Institute. In other parts of the temples, 15 bays had completely collapsed, the walls and beams of 39 bays had partially collapsed, and 20 bays were on the verge of collapse. In fact, some walls did collapse soon after the conservation project began, between winter 2001 and spring 2002.

Treatment Plan

Before conservation work began, the site was excavated to investigate the foundation of the collapsed buildings and establish the original levels of the courtyard and rooms. Archaeological data were supplemented with information about the original condition of the temple buildings obtained from interviews with people who had worked or lived at the site, from old photographs, and from old survey drawings.

The treatment plan was as follows:

1. Collapsed temple buildings would be rebuilt as close to their original condition as possible, based on the archaeological data; information obtained

from interviews, photographs, and survey documents; and using appropriate materials and traditional building techniques. The intent was to integrate the reconstructed components with the remaining ones.

2. For partially collapsed buildings, the collapsed areas would be reconstructed and the rest of the buildings restored and stabilized.
3. For the relatively intact buildings, only the lower parts of walls would be stabilized and strengthened.

The guiding principle for the conservation and restoration of the temples was that the structures should retain as much of the original fabric as possible. This approach is consonant with the China Principles guidelines and the heritage laws of China. A document from the State Administration of Cultural Heritage (SACH; formerly the State Bureau of Cultural Relics) specified how the work should be done: “For walls with efflorescence and cracks, the key point is to repair and reinforce the damaged parts; no excessive changes are allowed. Conservation of the floor tiles, decorations, nails and the nail holes on the walls, the pictures and bulletin boards should also receive attention. . . . And it is advisable to select local traditional materials for decorating houses and walls” (SACH 2001).

These treatment plan goals added to the difficulty of the project in that the work involved a conservation approach rather than one that adopted reconstruction as the guiding principle. Continuous testing was therefore necessary before appropriate treatments were decided on.

Restoration of the Upper Temple Complex

Restoration of building No. 10 in the Upper Temple complex is presented here to show the project’s challenges and activities.

Prior Alterations and Damage

Zhang Daqian, a famous painter, had lived in building No. 10 at the northeast side of the Upper Temple from 1942 to 1943 and, according to the recollection of several people interviewed, had created a painting on one of the walls in a room. Other people later occupied the room, and the painting was covered with whitewash many times. After the temple complex was abandoned, it quickly deteriorated. Many serious problems were apparent before the project began. Apart from the types of general deterioration already mentioned, a fire

had damaged the west wall of this building; modifications, such as conversion of a window into a fireplace, had been undertaken; new windows had been installed; and so on.

Repair

The general types of interventions undertaken during the project are described below.

Replacement of a Wall Foundation. Wooden boards and frames were used to support damaged walls before the deteriorated lower parts were undercut. The extent of cutting was based on the degree of deterioration. Wooden boards were used at the upper part of the cutting to support and stabilize the upper walls. During this procedure a trench about 1.5 meters long, 1.5 meters deep, and 1 meter wide was dug along the wall base. After the old footing was removed, the base of the trench was compacted. Then concrete was poured to form a foundation, after which a new footing of red brick was built. When the new footing reached ground level, a wall base was made of lime mortar and gray bricks (on the inner side of the wall there was one course and on the outer side three courses). Above the new base, mud plaster mixed with straw and adobe bricks that had been soaked in potassium silicate solution for added strength and durability were used to build up the base until it almost reached the bottom of the original wall, leaving a gap of about 1 centimeter. Then a 1:1 ratio of cement and clay mixture was used to fill the gap tightly. After the replacement was complete, the wall was plastered with a mixture of mud and straw, according to the original materials and technique used (fig. 3).



FIGURE 3 Wall stabilization with a brick footing.

Restoration of a Tilted Structure. The wooden framing and the gable springer for the earthen walls were returned to their original state at the same time. Securely propping up the walls involved great danger and difficulty. Walls that were not vertical or had subsided were corrected using a jack. Prior to being jacked up, the wall was supported, framed, and undercut following the procedures used for replacing the foundation of a wall. After the wall was pushed back to the vertical position, its footing and foundation were built up according to the procedures described above.

Repair of the Roof, Wall, and Surface. Since the roof was essentially intact, only a few changes were made during repair. The original layer of clay and straw covering the roof was removed, and a 2-centimeter-thick layer of new roof boarding and a felted waterproof layer were added over the original roof boarding. Then a layer of mixed clay and straw was added over the waterproof layer. This was reinforced by spraying with potassium silicate solution.

As mentioned, it was said that Zhang Daqian had executed a painting on the wall, but the exact place was not known. Removal of the coatings layer by layer revealed an ink painting of bamboo on the back wall, about 2 to 3 square meters in size. The surface was full of small pits that had been made so that the wall could be plastered. All the walls inside were likewise uncovered to expose this layer, and the pits were filled.

Grout containing potassium silicate was used to strengthen the bond between the original adobe bricks and between the adobe bricks and the plaster layer, during which cracks and detachments were also repaired. The procedure for grouting cracks was as follows: (1) the crack was sealed on

both sides of the wall, leaving a hole at an appropriate location to insert a grouting tube; (2) grout was then injected starting at the lower part of the crack and moving upward; and (3) after the tube was removed, the grout hole was sealed. The procedures for grouting cracks and detachments were identical, except that a presser was added to support the grouted area when detachments were repaired.

Decorative Carpentry. Although some structures had been restored many times, vestiges of the original wooden windows remained, and these were repaired with wood. When all the structures were finished, some work was done to make them look old and in harmony with the roof and wall.

Restoration of the Middle Temple Complex

The doors and windows of the two temples were repaired differently, reflecting their different uses over time. After 1943, when the Middle Temple became the office of the National Dunhuang Art Research Institute, the windows and doors were greatly changed. There were no radical or extensive changes to the Upper Temple. Therefore, the windows and doors of the Upper Temple were restored to their original form, and those of the Middle Temple remained in their modified forms from the 1950s and 1960s.

Restoring building No. 20, a wing house in the north of the backyard of the Middle Temple, was a key task since it had been the residence of Chang Shuhong, first director of the institute. This restoration was left to a later stage of the project. Other than repairing the earthen *kang* (heated bed), bookcase, and bookshelf (both also earthen), little else was done so that the hardships experienced during those early



FIGURE 4 Chang Shuhong's residence before restoration.



FIGURE 5 Chang Shuhong's residence in the 1940s, after the removal of nonoriginal interventions.

times could be preserved as witness to the early history of the Dunhuang Academy. Thus we achieved the aim of “restoring the relics to their original appearance” (figs. 4, 5).

Additional Restorations

Among the additional buildings restored during the project were a row of stables to the north of the Middle Temple and a mill room between the two temples. The stables were converted into a dormitory for employees after 1944 and have been in use ever since. The mill was a factory where the food for all the workers of the institute was processed.

Summary

In June 2004, after nearly two years of work and with support from leaders at all levels, the conservation of the Upper and Middle Temple complexes at the Mogao Grottoes was completed. This project was a new approach to repairing commemorative structures made of mud brick. The three groups taking part in the project—the Dunhuang Academy, the Getty Conservation Institute, and the Australia Heritage Commission—had no prior experience with this type of con-

servation, but through cooperation and hard work, the project was skillfully finished and recognized as such by those who had supported it.

On November 1, 2003, experts from the Gansu Provincial Cultural Bureau inspected and accepted the work done at the two temples. They commended the work, stating, “In the project, the original materials, structures, and techniques were strictly retained, and the cultural relics preserved to the largest extent. Repair of the surviving earth walls provides a new way and new techniques for conserving earthen constructions.”

References

- Agnew, N., and M. Demas, eds. 2004. *Principles for the Conservation of Heritage Sites in China = Zhongguo wen wu gu ji bao hu zhun ze [Chinese-language document] issued by China ICOMOS; approved by the State Administration of Cultural Heritage*. Los Angeles: Getty Conservation Institute.
- State Administration of Cultural Heritage (SACH), PRC. 2001. Document No. 890, addressed to the Dunhuang Academy.

Consolidation Studies on Sandstone in the Zhongshan Grotto

He Ling, Jiang Baolian, Zhou Weiqiang, and Zhen Gang

Abstract: The Zhongshan Grotto is located in Yan'an district, Shaanxi province. The grotto was created initially in the Eastern Jin dynasty, dating from 366 C.E., and was worked again during the Song dynasty (1067). The grotto was excavated out of a fine-grained sandstone rich in the mineral feldspar. The grotto and its statues show different degrees of weathering, primarily at ground level and up to 2 meters in height. The grotto rock shows severe friability and exfoliation, the color on the rock surface has faded, and cracks and fissures have occurred. As a result, many statues have only blurred outlines.

This paper describes the factors and mechanisms contributing to weathering of the grotto. X-ray diffraction, thin section analyses, and scanning electron microscopy identified the physical and mechanical properties of the sandstone. In addition, a fluorinated polymer and two silicon compounds were used in a consolidation study. The effectiveness of the fluorinated polymer for consolidating the sandstone was systematically examined for polymer formation, penetration depth, porosity, capillary and osmotic coefficient, water uptake, compressive strength, absorption of water vapor, water vapor permeability, color changes, thermal expansion cycles, freeze-thaw cycle testing, and accelerated weathering in 10 percent sulfuric acid. The results show that the fluorinated polymer satisfied chemical and freeze-thaw resistance, and the rock remained stable in dimension. When the consolidant penetrated the sandstone to more than 5 centimeters in depth, the strength increased significantly and was evenly distributed with depth. We conclude that an appropriate concentration of the fluorinated polymer provides ideal consolidation of the Zhongshan sandstone.

The Zhongshan Grotto is located 60 kilometers from Yan'an, in northern Shaanxi province. It is an important historic grotto on the Silk Road that was first carved in about 366 C.E. during the Eastern Jin dynasty and worked again in 1067 C.E. during the Song dynasty. Since 1988 the Zhongshan Grotto has been listed among the key cultural sites of China. There are five caves and three gates carved into the mountain, and they face south toward the Xiu Yan River, following tradition. Eight carved stone pillars support the stone roof of the main cave, which contains an 11.5-meter-wide Buddha altar situated 5 meters from the entrance (fig. 1). There are sixteen Buddha figures carved out of the wall surrounding the altar, and these figures are well painted.



FIGURE 1 Buddha altar and carved stone pillars in the main cave of the Zhongshan Grotto.

The grotto is excavated out of a porous fine-grained sandstone rich in the mineral feldspar. The sandstone is gray, with some dark brown marks. Because of the grotto's location in the severe environment of northern China and its exposure to wind erosion, the stone surface has deteriorated seriously. Humidity combined with salts is another deterioration factor. Water migration has caused salts to accumulate in the rock, producing crystals that weaken the bonding between the sandstone grains. This deterioration results in heavy efflorescence on the rock surface, loss of the surface layers, loss of the binding materials between the grains of quartz, powdering of the stone, loss of detail of the sculpture, fading of the wall painting, and many fissures or cracks in the cave wall. The greatest deterioration is seen 2 meters above the ground, resulting from the capillary rise of water in the sandstone and the windy environment. This is especially noticeable on the side of the cave that backs to the mountain.

The aim of our work was to investigate the deterioration of the sandstone in Zhongshan Grotto and to study the effect of several consolidant materials on the physical, mechanical, and thermal properties of the sandstone to see how they compensate for the loss of the natural binding materials from the stone. The physical, mechanical, hygric, and thermal properties were determined for treated and untreated samples of the sandstone materials. The following were examined: polymer formation time, penetration depth, porosity, capillary absorption and penetration coefficient, water uptake, compressive strength, drilling resistance, water vapor diffusion, color changes, and resistance to disaggregation by water and freeze-thaw cycles. In addition, the effect of acid deterioration (i.e., accelerated weathering) was assessed. An in situ demonstration of several consolidants was conducted in a second cave at Zhongshan Grotto.

Samples

Samples were taken both from the sandstone surface inside the main cave and from the unweathered sandstone. Samples of salt efflorescence were obtained by scraping the weathered and unweathered surface with a small knife. Thin-section samples were taken in the same place. About 150 small stone block samples were also taken from outside the grotto. The samples measured 5 by 5 by 0.5–1.5 centimeters, 5 by 5 by 8–15 centimeters, and 5 by 5 by 5 centimeters. Each measurement was repeated at least three times, and the average value is quoted in each case.

Deterioration Study

Analytical Methods

X-Ray Diffraction (XRD) Analysis. For XRD analysis, samples were ground into a fine powder in an agate mortar and pressed into the specimen holder, then mounted in a D/MaX-rA X-ray diffractometer. Operating conditions were Cu target; 45 kV; 80 mA current; speed, 0.1; chart, 5; time constant, 1; monochromatic system, graphite.

Thin-Section Analysis. Sandstone samples were sectioned and polished, then mounted on microscope slides. The grain structure, texture, grain size, grain shape, grain contact, matrix, pores, composition, and so on were identified using a polarizing microscope.

Salt Analysis. The scraped samples of salt efflorescence were ground into a fine powder in an agate mortar after sand grains were removed (under the microscope) and then were analyzed by XRD. Diffraction patterns were interpreted by comparison with Joint Committee for Power Diffraction Standards (JCPDS) data.

Accelerated Weathering Analysis. The aging of samples was performed after a four-week interval of treatment. Fifty freeze-thaw cycles were used. Each cycle consisted of soaking the sample in water for 4 hours at 20°C to 25°C, removing it from the water and freezing it for 4 hours at -4°C to -10°C, and then soaking it in water again for 4 hours at 20°C to 25°C. A total of fifty thermal cycles were used. Each of these cycles consisted of heating the sample for 4 hours at 100°C to 110°C, cooling for 4 hours at 20°C to 25°C, and then drying again for 4 hours at 100°C to 110°C. Erosion in sulfuric acid was carried out by immersing the samples in 10 percent acid for one week.

Deterioration Study Results and Discussion

Thin-Section Analysis

The composition and properties of the weathered and unweathered samples determined by thin-section analysis are presented in table 1. The results show that both sets of samples belong to a feldspathic sandstone family. The main composition is quartz, 30 to 45 percent; plagioclase feldspars, 25 to 30 percent; hematite, 1 to 2 percent; chlorite, <1 percent; and mica, 3 to 5 percent. The sand grains were rhombus or subrhombus in shape. Because the grain size is small, about 0.25 to 0.09 millimeter, the Zhongshan sandstone is defined as fine grained. Clay fills the pores of the sandstone, but the

Table 1 Description of Thin Sections

Sample	Description of Thin Sections
Unweathered stone	<p>Class: fine feldspathic sandstone with grain size 0.25–0.09 mm</p> <p>Composition: quartz 30–45%, plagioclase feldspar 25–30%, chlorite <1%, hematite 1–2%, mica 3–5%</p> <p>Filler: mica clay and ferric minerals</p> <p>Porosity: 10–15% with pore size from 0.1 mm to several mm</p>
Weathered stone	In general, similar to unweathered stone with the following exceptions: (1) less ferric minerals and (2) more pores with smaller pore size

ferric minerals are within the grains. In thin section, the weathered sample contains less ferric mineral and has more pores with smaller pore size than the unweathered samples.

XRD Analysis

The results of XRD analysis of unweathered sandstone samples are similar to those obtained from thin-section analysis: quartz, 44 percent; sodium feldspar and microcline, 32 percent + 3 percent; with trace amounts of other minerals, totaling 21 percent. For the weathered samples, the amount of feldspar increases to about 46 percent (albite feldspar and microcline feldspar), quartz is at 32 percent, and chlorite is a bit high at 7 percent. See table 2.

Causes of Deterioration

Clays. The structure and composition of the sandstone show that it deteriorates easily in the local environment. Clay minerals from weathered feldspar swell with water, especially smectite ($\text{Al}_2[\text{Si}_4\text{O}_{10}](\text{H}_2\text{O})_2 \cdot n\text{H}_2\text{O}$). Smectite contracts on drying. Repeated swelling and contraction destroys the strength of the sandstone and produces cracks. All of these actions contribute to the powdery and sandy nature of the weathered sandstone in the Zhongshan Grotto.

Porosity and Pore Size. In addition, the porosity and pore size of the sandstone make it possible for water to penetrate the rock, dissolving some minerals. This also reduces the rock strength. The larger porosity and smaller pore size of the exterior stone are a typical consequence of dissolution by water.

Table 2 XRD Analysis Results for Zhongshan Sandstone

Sample	Mineral Composition
Unweathered	Quartz: 44%; sodium feldspar: 32%; illite and smectite: 5%; siderite: 5%; chlorite: 4%; kaolinite: 3%; microcline: 3%; zeolite: 2%; other: 2%
Weathered	Albite feldspar: 38%; quartz: 32%; microcline feldspar: 8%; chlorite: 7%; illite: 5%; calcite: 5%; zeolite: 2%; other: 3%

Salts. Soluble salts in sandstone also play an important role in the deterioration process. XRD analysis results revealed that salts can be dissolved, transported to, and then leached from the surface of the stone. Salt crystallization-dissolution cycles occur with humidity changes in the dry, cold environment of the Zhongshan Grotto. This process also results in cracks, fissures, powdering, and flaking of the sandstone.

Water movement and salt precipitate were inferred from the presence of decomposition of kaolinite and the increase of albite in XRD analysis. This confirmed the role of chemical weathering in the deterioration of the stone, with the resulting transformation of the constituent minerals into other minerals more susceptible to mechanical strain and dissolution. Even quartz, one of the most durable minerals, showed susceptibility to mechanical deformation as a result of stress from static or dynamic loads.

On the other hand, the crystallization-dissolution cycles of salts, together with the typical windy weather in the region, have altered the pigments inside the Zhongshan Grotto such that many areas of the painted figures in the main cave have become black (fig. 2), or only a vague outline of the image remains because of soluble salts (fig. 3). The paint was applied directly to the stone surface. Paint layers have peeled off, and binding materials have likely deteriorated.

Salts are a powerful weathering agent, especially when combined with freezing temperatures. The Zhongshan Grotto is located in a region where the temperature in winter is often -20°C , so freezing is a serious contributor to deterioration.

All these factors, either endogenous from the physical and chemical properties of the stone or exogenous from the surrounding environment, are able to transform the sandstone from a hard, strong, coherent state into a completely



FIGURE 2 Painted figures blackened by deterioration.

disintegrated, weak state. This will lead ultimately to complete destruction of the stone in the future.

In the second part of our investigation, described below, we tested several consolidants as a substitute for the natural binding materials. It is to be expected that the friable sandstone treated with these consolidants will gain new properties, becoming more resistant to deterioration in the future. Several of the most promising consolidants were then evaluated during an in situ demonstration in a second cave.

Consolidation Study

Experimental Consolidants

The consolidants used were a fluorinated polymer and organosilicon materials. Fluorinated polymers are well known for their excellent weathering and oxidation resistance and the mechanical properties they impart to stone (McLain, Sauer, and Firment 1996; Alessandrini, Toniolo, and Colombo 2000; Ciardelli et al. 2000). These characteristics directed our attention to this kind of polymer for the consolidation study. We synthesized a multifunctional and partially fluorinated polymer, called F4-SS (F = fluorinated-containing, 4 = four monomers, SS = stone strengthener), specifically for sandstone conservation (He Ling and Liang Guozheng 2003). This is a copolymer prepared with four monomers: tetrafluoroethylene (C_2F_4), vinyl acetate ($CH_2COOCH:CH_2$), allyl alcohol ($CH_2:CHCH_2OH$), and 10-hendecenoic acid ($CH_2:CH(CH_2)_8COOH$). The F4-SS copolymer formula is shown below.



FIGURE 3 Figure eroded by soluble salt and water.

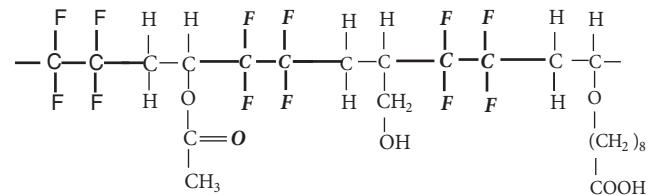

F4-SS has a strong ability to combine with the minerals in sandstone, achieves sufficient penetration depth, and provides essential consolidation strength. The important point is that it is soluble in common solvents, and it has a high glass transition temperature (He Ling and Liang Guozheng 2003). F4-SS was used at concentrations of 5 percent, 20 percent, and 30 percent in butyl acetate (ASTM C67-97 1997).

Two organosilicon compounds (Remmers 300 and WD-02) and mixtures of F4-SS + WD-102 were also used as consolidants to compare their properties.¹

Experimental Method

Sandstone samples were cut into cubes (5 cm^3) and dried in an oven at 105°C for 24 hours until constant weight, then cooled to room temperature and 55 percent relative humidity for half an hour and weighed again.

Two consolidation methods were used in this study: capillary absorption parallel to the bedding plane and capillary absorption perpendicular to the bedding plane. After the consolidant was applied, it was allowed to cure for four weeks before analysis.

Treatment Evaluation

Gel Formation and Penetration Depth. Gel formation of the different consolidants was determined by weight change of the treated samples after four weeks of curing. The penetration depth of the applied consolidants was measured by capillary rise through the 5-cubic-centimeter cubes.

Hygric Properties. Porosity, water uptake, hygric dilatation, water absorption coefficient, water penetration coefficient, water vapor diffusion, and water vapor absorption were determined according to ASTM C67-97 (1997) for the treated and untreated samples.

Color Change. Evaluation of color changes between the treated and untreated samples was carried out with a MINOLTA CR-300 colorimeter.

Compressive Strength and Accelerated Weathering. After four weeks of curing, treated and untreated samples were subjected to fifty freeze-thaw cycles, thirty heat cycles at 100 to 110°C, and 10 percent H_2SO_4 , and then compressive strength was determined. Compressive strength was determined according to ASTM C67-97, with the load applied perpendicular to the bedding plane. Compressive strength before and after aging was measured for treated and untreated samples.

Scanning Electron Microscope (SEM) Analysis. To evaluate the effects of the consolidants, the treated and untreated samples were examined by SEM analysis using a HITACHI S-570. The samples were coated with gold to a thickness of 110 nanometers. The SEM micrographs were also examined to find the difference before and after aging.

Consolidation Study Results

Gel Formation and Penetration Depth

Figure 4 shows the gel formation over the four-week curing process. Samples treated with F4-SS had a constant weight after two weeks, but the samples treated with Remmers 300 and WD-02 needed at least a month to achieve constant weight. The initial absorption of the F4-SS was proportional to the viscosity of the preparation used. Because the 5 percent solution has the lowest viscosity, it had the largest absorption; conversely, the 30 percent high-viscosity solution had the least absorption. But the final gel content is proportional to the concentration of fluorinated polymers. The amounts of Remmers 300 and WD-02 absorbed by the samples were more than the amount of F4-SS absorbed because of their higher concentration.

Table 3 Consolidant Penetration Depth Measured by Capillary Rise through Sample

Consolidant	Penetration Depth (cm)		% Increase
	At 10 Min.	At 4 Weeks	
5% F4-SS	2.5	4.1	64
20% F4-SS	1.5	5.0	233
30% F4-SS	3.4	3.6	6
WD-02	2.2	3.2	45
Remmers 300	2.3	3.1	35

The penetration depths of the consolidants were compared by measuring capillary rise through the 5-cubic-centimeter cubes. Table 3 presents the results. It was found that the depth after four weeks was two to three times greater for the F4-SS solutions, although the capillary absorption of samples of 5 by 5 by 8–15 centimeters was carried out within the same time. The 20 percent F4-SS increased the most after four weeks; the 30 percent F4-SS, the least due to its higher viscosity and due to its polymerization at the surface of the stone sample. The mixed polymer of F4-SS + WD-10 performed similarly to the 20 percent F4-SS. WD-02 and Remmers 300 gave about 45 to 35 percent increase in penetration depths.

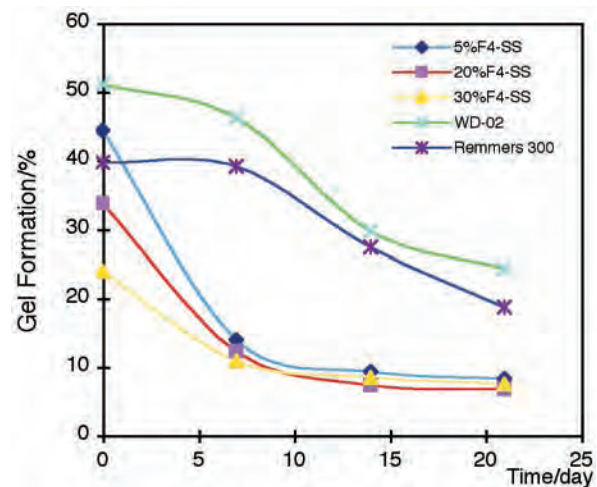

FIGURE 4 Gel formation over the four-week curing process.

Hygric Properties

Porosity and Water Uptake. Porosity of the treated and untreated samples was determined according to ASTM C97 (table 4). The results indicated that the porosity of all samples, either under vacuum for 24 hours or in boiling water for 5 hours, was nearly the same. The higher the concentration of F4-SS, the more the porosity decreased for treated samples. At 5 percent F4-SS, there was little reduction in porosity compared with that of untreated stone because a very thin film formed on the mineral surface and after the solvent evaporated. The film thickness in the pores increased with the concentration of F4-SS, and the porosity decreased. In addition, porosity is related to the test method: fluorinated polymer has a significant hydrophobic property, which can cause the porosity to be relatively lower.

Water uptake is the water absorption under atmospheric pressure for 24 hours. Water absorption of the treated and untreated samples was determined according to ASTM C97 (see table 4). The variation in water uptake showed exactly the same tendency as porosity because porosity is closely related to water uptake and water transport. The water uptake of the mixed system F4-SS + WD-10 was lower because of the addition of WD-10, a long-chain organosilicon that has a significant hydrophobic effect.

Water Absorption and Penetration. The influence of capillary processes in stone is expressed by the water absorp-

tion coefficient (*W*) and the water penetration coefficient (*B*). Values obtained for *W* and *B* in our consolidation study are given in table 4. All treated samples showed a decrease in *W* and *B* values compared with the untreated sample. The *W* and *B* values decreased with increasing fluorinated polymer content: 30 percent F4-SS showed extremely low *W* and *B* values. WD-02 and Remmers 300 performed similarly. The mixed system of F4-SS + WD-10 showed a decrease in capillary absorption, penetration, and porosity, and the degree of decrease was proportional to the concentration of WD-10.

Hygric Dilatation. Cracking and flaking of stone are caused by swelling due to water absorption. Dilatation was measured for all the samples. The results are given in table 4. It is clear that dilatation correlates with *W* and *B* values. Samples treated with 20 to 30 percent fluorinated polymers showed less dilatation than those treated with the silicon polymers (WD-02 and Remmers 300). The mixed system of F4-SS + WD-10 gave a value between those of the two separate polymers.

Water Vapor Diffusion. Water vapor diffusion, μ , measures water vapor movement through a medium. The higher the value of μ , the more difficult it is for water vapor to diffuse through the medium. At all three concentrations, F4-SS had similar diffusion values. Adding WD-10 to the F4-SS slows diffusion. Experiments showed that the sample surface remained dry when pure F4-SS was used; however,

Table 4 Hygric Properties of Stone Samples

Consolidant	Porosity (%)	Water Uptake (%)	Water Absorption Coefficient, <i>W</i> (kg·m ⁻² ·h ^{-1/2})	Water Penetration Coefficient, <i>B</i> (cm·h ^{-1/2})	Hygric Dilatation (μm·m ⁻¹)	Water Vapor Diffusion (μ)
5% F4-SS	9.3	8.40	2.02	1.02	1193	7.37
20% F4-SS	7.7	8.01	0.28	0.79	395	9.07
30% F4-SS	4.4	5.72	0.03	0.01	791	10.15
20% F4-SS + 20% WD-10	0.9	3.38	0.06	0.21	791	16.93
20% F4-SS + 10% WD-10	4.2	3.03	0.16	0.01	790	9.80
20% F4-SS + 5% WD-10	2.5	3.36	0.08	0.16	1197	27.62
WD-02	6.2	6.94	1.07	3.28	1188	11.59
Remmers 300	5.8	8.20	1.18	1.4	1179	7.61
Untreated	16.8	9.17	4.10	3.29	1296	7.03

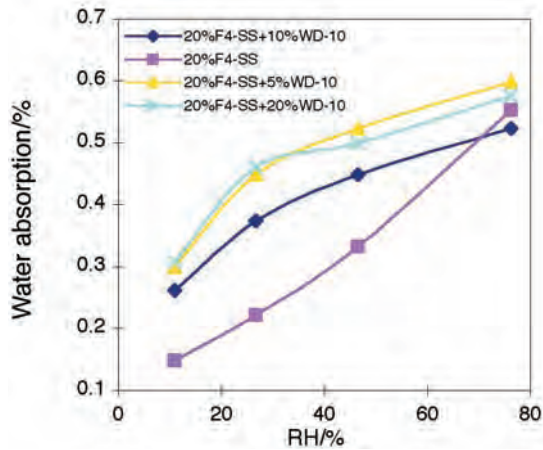

FIGURE 5 Water vapor absorption isotherms for different consolidants.

water drops accumulated on the surface when a mixture of F4-SS and WD-10 was used. This indicated that water vapor was unable to diffuse through the sample, and water drops were formed on the rock surface. Table 4 shows the results of these tests.

Water Vapor Absorption Isotherm. Different relative humidity environments were generated using four saturated salt solutions: 11 percent (LiCl), 35 percent (MgCl₂), 58–60 percent (NaBr), and 76 percent (KHSO₄). Figure 5 shows the water vapor absorption isotherms. Remmers 300 exhibited the largest water vapor absorption above 20 percent RH. The three fluorinated polymer concentrations did not significantly affect the samples, and treated samples exhibited water absorption similar to that of the untreated sample. The addition of WD-10 results in a little more water absorption than that achieved with the pure fluorinated polymers.

Color Variation. Figure 6 shows the color variation of samples treated with several consolidants. The results were obtained by comparison with an untreated sample. WD-02 caused the most color change; the fluorinated polymers and Remmers 300 caused a small amount of color change.

Compressive Strength and Accelerated Weathering. Compressive strength measurements were carried out at different stages for treated and untreated samples: at four weeks after treatment, after fifty freeze-thaw cycles, after thirty heat expansion cycles at 100°C to 110°C, and in 10 percent H₂SO₄. Average values of compressive strength are listed in table 5.

The untreated samples had an average compressive strength value of 47 MPa. After the treated samples were allowed to cure for four weeks, those treated with 30 percent F4-SS had the highest value: 89 MPa. WD-02 and

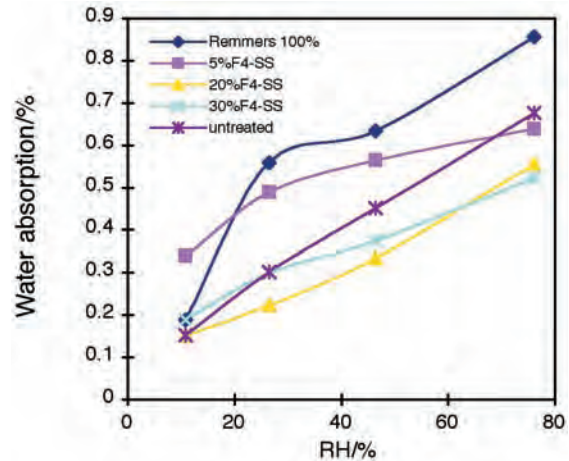

Remmers 300 had high values because of their 100 percent concentration, without dilution with solvent.

After fifty freeze-thaw cycles, samples treated with all three concentrations of F4-SS showed the smallest percentage decrease in compressive strength, about –16 to –37 percent, as shown in table 5, while those treated with mixtures of F4-SS + WD-10 showed the largest decrease percentage, –50 to –75 percent. Results for samples treated with WD-02 and Remmers 300 lay between these two ranges. During the freeze-thaw cycles, the sample treated with 20 percent F4-SS + 20 percent WD-10 cracked in forty-two cycles, and the sample treated with 20 percent F4-SS + 10 percent WD-10 cracked in thirty-five cycles.

After thirty thermal expansion cycles, the sample treated with 5 percent F4-SS was the only one that showed an

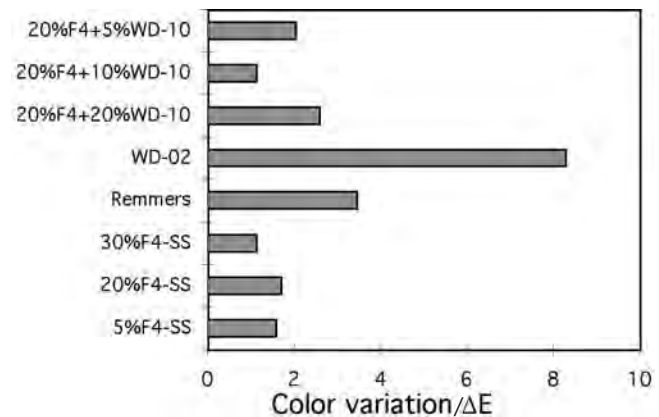

FIGURE 6 Color change measured for different consolidants.

Table 5 Compressive Strength Test Results

Consolidant	Compressive Strength (MPa)*			
	At 4 Weeks Posttreatment	After 50 Freeze-Thaw Cycles	After 30 Thermal Expansion Cycles	After Erosion in 10% H ₂ SO ₄
5% F4-SS	52.64	44.30 (-15.8)	55.35 (+5.2)	41.24 (-21.7)
20% F4-SS	61.83	49.47 (-20)	49.21 (-20.4)	56.77 (-8.2)
30% F4-SS	88.86	56.29 (-36.6)	63.73 (-28.3)	61.27 (-31.0)
20% F4-SS + 20% WD-10	73.28	23.51 (-67.9)	44.84 (-38.8)	36.99 (-49.5)
20% F4-SS + 10% WD-10	43.65	10.93 (-74.9)	30.56 (-30)	32.18 (-26.3)
20% F4-SS + 5% WD-10	71.20	31.62 (-55.6)	58.33 (-18.1)	32.16 (-54.8)
WD-02	81.53	49.70 (-39.1)	71.43 (-12.4)	40.41 (-50.4)
Remmers 300	83.47	45.04 (-46)	71.82 (-13.9)	41.57 (-50.2)
Untreated	47.29	42.38 (-10.4)	43.25 (-8.5)	32.31 (-31.7)

*Numbers in parentheses indicate % increase (+) or decrease (-) in compressive strength.

increase in compressive strength (+5%); all other treated and untreated samples had decreased values.

These results indicate that samples treated with WD-02 and Remmers 300 have better thermal resistance than those treated with fluorinated polymers, but they have poorer H₂SO₄ erosion resistance. These results can be explained by the property of consolidant mixtures. A 5 percent F4-SS mixture contains much more solvent than the others. Continued polymerization occurred during drying at 100°C to 110°C, causing an increase in compressive strength. When samples were treated with 30 percent F4-SS, polymerization occurred at the sample surface, but the temperature of drying samples in 100°C to 110°C is higher than the glass transition temperature (T_g) of F4-SS polymer, so the film softened and caused the decrease in compressive strength. Samples treated with WD-02 and Remmers 300 showed good thermal resistance because of the chemical combination between polymer and stone.

SEM Analysis. SEM was used to evaluate the consolidants. SEM micrographs of samples treated with the different consolidants were obtained. SEM images for samples treated with 20 percent F4-SS show the sandstone grains coated with a homogeneous smooth film (figs. 7a, b). Sandstone grains in the samples treated with WD-02 and Remmers 300 are

not coated with the consolidant; instead, the network structure of the polymer gel has spread over the grain surfaces. SEM images of the sample treated with a mixture of F4-SS + 10 percent WD-10 just formed a very thin layer on the sample surface, leaving the quartz grain boundaries visible, and failed to fill fine cracks; therefore they were excluded from further tests.

SEM was used to study the penetration of the different consolidants. The low-viscosity consolidants of F4-SS showed good penetration. SEM also confirmed the failure of 30 percent F4-SS to penetrate the internal structure of the stone, either by capillary absorption or by total immersion absorption. This is due to its high viscosity and its fast polymerization. This is also the reason for the decreased porosity and water absorption values of samples treated with this consolidant.

SEM examination also showed that the macro pores are open when treated with a low concentration of F4-SS, permitting air movement inside the stone. This also makes it possible for salts to effloresce on the surface in situations when salts exist inside the structure of the stone. SEM images of H₂SO₄ erosion on samples treated by F4-SS revealed that only a few holes on the sample surface were formed after erosion; H₂SO₄ did not destroy the film.

FIGURE 7 SEM image of sample treated with 20 percent F4-SS showing (a) network and (b) sandstone grains coated with a homogeneous smooth film. 60,000× magnification.

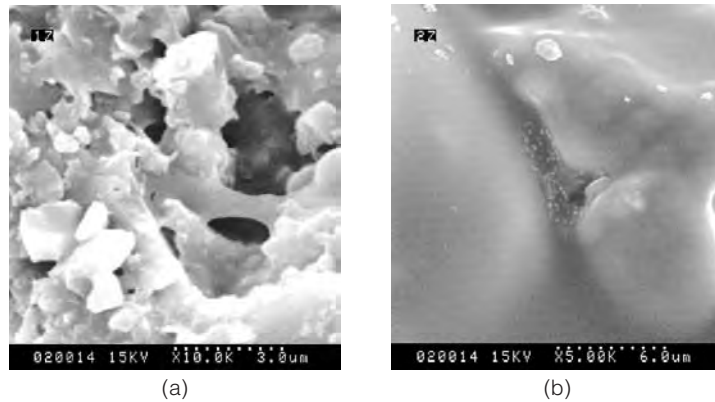

In Situ Consolidation Demonstration

The effectiveness of the different consolidants was tested during an in situ demonstration in a cave at Zhongshan Grotto where the figures have been entirely lost. The demonstration was conducted during winter, and after one year of treatment in situ (2002), the treated sections were tested and evaluated. Because of the limited demonstration area provided, just four consolidants were used for the treatment: 20 percent F4-SS, 5 percent F4-SS, WD-02, and Remmers 300.

A 0.4-square-meter demonstration area was selected on the west side of the cave about 2 meters above the ground. This area was divided into four test sections, each to be separately treated by 20 percent F4-SS, 5 percent F4-SS, WD-02, and Remmers 300. Each section measured 720 square centimeters, with a 200-square-centimeter space left between adjacent sections.

Dust and surface efflorescence were first brushed off the test sections. Then the consolidants were applied at 0.57 to 0.8 kilogram per square meter. After one year, the four treated sections were tested for color variation, water absorp-

tion (by Kust-tube measurement), and drilling resistance. Results are given in table 6.

Figure 8 shows that the different consolidants perform similarly with respect to water absorption, with the exception of WD-02 in water uptake. The figure also shows that water absorption is continuous, without a turning point, which suggests also that the consolidation treatment is uniform from grotto surface to the interior. Because of exceptionally heavy precipitation in 2002, the test results should over time reflect the influence of water on the materials used.

Conclusion

Preliminary results from the yearlong in situ consolidant demonstration show that 5 percent F4-SS and 20 percent F4-SS, due to their low viscosity (similar to that of water), successfully penetrated the test sections and bound the friable sandstone grains into a hard structure.

F4-SS, a multifunctional polymer, contains a long alkyl chain; and because of its fluorine atoms, it has excellent anti-aging properties and water repellency. It contains hydroxyl

Table 6 Consolidant Demonstration Test Results

Test Section	Consolidant	Color Change (ΔE)	Water Uptake / $s \cdot ml^{-1}$	Drilling Resistance ($\Theta/10$)
A	Remmers 300	2.01	322.6	14.6
B	WD-02	1.73	173.7	12.6
C	20% F4-SS	2.98	273.3	13.4
D	5% F4-SS	1.85	265.6	14.4
Untreated	—	—	214.6	11.8–15.4

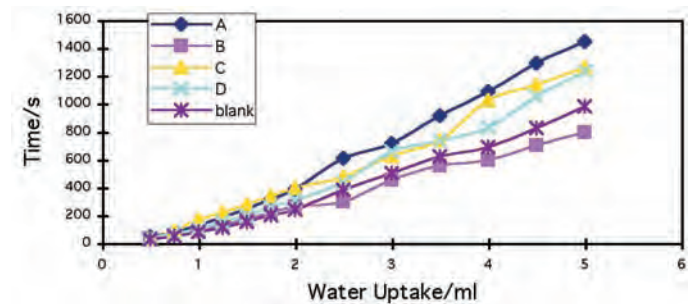

FIGURE 8 Water uptake for test areas A–D of in situ consolidant demonstration.

and acidic groups, which provide bonding to the stone surface. Therefore, fluorinated polymers can form a uniform film on the surface of the sandstone's mineral grains and bind them together, as well as fill in pores, which enhances the strength of stone. In the case of highly deteriorated stone, where a strong binding agent is needed to hold the grains together, it is possible to apply a higher concentration of fluorinated polymer. But no more than 30 percent should be used because of the high viscosity, decreased penetration, and rapid polymerization on the stone surface.

Accelerated weathering tests indicate that the fluorinated polymers provide treated stone with a longer life span, a stronger waterproof capacity, and increased resistance to acid. Thus fluorinated polymers should prevent stone from being attacked by acid water or rain. Because treatment with fluorinated polymers does not obviously influence porosity or water vapor permeability of the stone, these consolidants should be effective in reducing weathering. The treatment does not block the pores of the stone, so it should be possible to retreat stone successfully.

Notes

- 1 Remmers 300 was obtained from the Remmers Company, Germany. WD-02 is an alkyltrimethoxysilane, $C_{10}H_{21}Si(OCH_3)_3$, obtained from Wuhan University, tel. 027-87215023, 87214371, e-mail: sale@wdsilicone.cn. The mixtures of F4-SS + WD-10 were obtained from Wuhan University, Hubei province, China.

References

- Alessandrini, G., L. Toniolo, and C. Colombo. 2000. Partially fluorinated acrylic copolymers as coatings for calcareous stone materials. In *Tradition and Innovation: Advances in Conservation: Contributions to the Melbourne Congress, 10–14 October 2000*, ed. A. Roy and P. Smith, 1–6. London: International Institute for Conservation of Historic and Artistic Works.
- ASTM. 1997. *Standard Test Methods for Sampling and Testing Brick and Structural Clay Tile*. ASTM C67-97.
- Ciardelli, F., M. Aglietto, V. Castelvetro, O. Chiantore, and L. Toniolo. 2000. Structurally modulated fluoropolymers for conservation of monument stones: Synthesis, stability and applications. In *Proceedings of the New Millennium International Forum on Conservation of Cultural Property, 5–8th December 2000, Deajeon, South Korea*, ed. Suckwon Choi and Mancheol Suh, 166–81. Kongju, Korea: Institute of Conservation Science for Cultural Heritage, Kongju National University.
- He Ling and Liang Guozheng. 2003. Fluorinated membrane polymers as coatings for the conservation of culture properties. *Mo ke xue yu ji shu = Membrane Science and Technology* 23 (3): 40–45.
- Mclain, S. J., B. B. Sauer, and L. E. Firment. 1996. Surface properties and metathesis synthesis of block copolymers including perfluoroalkyl-ended polyethylenes. *Macromolecules* 29 (25): 8211–19.

Nonaqueous Dispersions and Their Antiweathering Performance for Earthen Buildings, Monuments, and Archaeological Sites

Zhou Shuanglin, Yuan Sixun, Guo Baofa, and Xia Yin

Abstract: *Commercially available aqueous dispersions of acrylic and silicon polymers were transformed into nonaqueous dispersions in organic solvents and after laboratory testing and evaluation on loess earth have been applied in limited though quite large areas at a number of Chinese archaeological sites, including the Terracotta Warriors (pit 1), the Neolithic site of Niheliang, and the Fayuan Temple in Beijing. Results are positive.*

Natural weathering is important in the deterioration of earthen archaeological sites and constructions. In China many archaeological sites, for example, Banpo in Shaanxi and Dahecutn in Henan, are sheltered by buildings and are part of site museums. However, there are other sites left in the open air. Many of the latter show signs of deterioration, such as salt efflorescence and biological growth. To prevent these sites from weathering, many methods, such as surface consolidants and drainage, have been used.

Chemicals typically used as antiweathering agents are silicones, acrylics, polyurethanes, and organic latexes. These are effective in preserving earthen constructions from weathering, but each has disadvantages. Clay samples treated by acrylics show a change in color and disintegrate during water immersion tests; those treated with polyurethane also have a distinct color change, though they are resistant to water; treatment with tetraethoxysilane results in brittleness and poor freeze-thaw resistance; and silicones also show color change.

In order to choose a suitable chemical for preservation of exposed earthen constructions, we tested a number of chemicals. Acrylic latex showed good consolidation, and clay samples treated with low-solid-content acrylic latex had little

or no color change and were stable in water and freeze-thaw tests. The disadvantage was that the test samples disintegrated during treatment because of the high water content in the latex.

The question, then, was how to overcome the disadvantage of aqueous acrylic latex. Could we exchange water for organic solvents? Nonaqueous systems for the latex seemed to offer the best alternative. A nonaqueous dispersion consists of high molecular polymer particles (diameter 0.01–30 μm) dispersed in organic solvents. The polymer is not dissolved in the solvent but is dispersed in it, similar to a colloidal suspension. Two methods were used to produce nonaqueous dispersions:

- Polymerization: Monomers were polymerized in nonaqueous solvents by dispersion polymerization, which has been discussed in related patents (Walbridge 1973).
- Transfer: When organic solvent with surfactant is added to aqueous organic latex, the latex becomes unstable and agglomerates from the water phase, and transfer of polymer particles to the organic phase occurs, resulting in a nonaqueous dispersion. This method was first developed during the period 1970–80 (for patents, see Campion and Yardly 1971; Keown 1973). The transfer method is generally easier than polymerization, and the nonaqueous dispersion formed has a high solid content and low viscosity.

After many years of development, polymer latexes synthesized by emulsion polymerization have generated a vari-

ety of products for different requirements. Room temperature self-cross-linking acrylic latex and silicon-modified acrylic latex are categories of polymers that provide outstanding performance; the former leads the latex to form an organic film with different glass transition temperature (T_g) based on the latex composition and has good antiaging properties; the latter has better long-term stability than the former due to the silicon group. In this study several new species of room temperature self-cross-linking acrylic latexes and silicon-modified acrylic latexes were transferred to nonaqueous dispersions for testing and application.

Latexes

Acrylic Latex

- BA-154, BC-2021, and BC-4431, produced by Dongfang Chemical Plant, Beijing (table 1)

Silicon-Modified Acrylic Latex

- BC-251M, produced by Dongfang Chemical Plant, Beijing
- KX 2002, produced by Kexin Chemical Co., Beijing
- TD-1, produced by Sunrise Chemical Co., Jiangsu

All the latexes listed above were transformed into nonaqueous dispersions by the transfer method. The organic solvents used to disperse the polymer particles were cyclohexane, hexane, methylethyl ketone, cyclohexanone, and alcohol. The

Table 1 Properties of Acrylic Latexes

Sample	Appearance	Solid Content	pH	MFFT°C	T_g
BC-4431	White liquid	41 ± 1%	6.5~7.7		41°C
BC-2021	White liquid	50 ± 1%	7~9	18°C	20°C
BA-154	White liquid	60 ± 1%	3.5~5		0°C

	Viscosity (mPa)	Composition
BC-4431	350~1500	Copolymer of styrene and ethyl acrylate
BC-2021	<500	Copolymer of acrylate monomers
BA-154	100~550	Copolymer of acrylate and a functional group

nonaqueous dispersions transferred from BA-154, BC-2021, and BC-4431 are labeled 54J, 21J, and 31J, respectively.

Properties of the Dispersions

The properties of the latexes and acrylic nonaqueous dispersions and the film formed after the evaporation of the dispersants are presented in table 2.

Particle Size

Particle size was determined by transmission electron microscopy (TEM) after dilution to 1 percent and drying on a copper film at -25°C . Contrast was improved by dyeing with mercurochrome.

Viscosity

An Ubbelohde viscosimeter was used to determine the viscosity of 1~15 percent dispersions in cyclohexanone (table 3). Viscosity of acrylic nonaqueous dispersion increases rapidly with concentration. Silicon-modified acrylic nonaqueous dispersions show similar behavior.

Stability

High-solid-content (<15%) nonaqueous dispersions stored at room temperature for one year are stable and could be used

Table 2 Radius Determined by TEM

	Radius of Particles (nm)	
Latexes	BC-4431	50
	BC-2021	100
	BA-154	150~400
Nonaqueous dispersions	31J	50
	21J	75
	54J	—

Table 3 Viscosity of Three Nonaqueous Dispersions at 25°C

Sample	(mPa)				
	1%	3%	7%	11%	15%
31J	3.35	6.52	17.0	38.0	66.2
21J	3.82	5.96	8.75	21.0	39.1
54J	2.74	3.63	10.2	85.9	

to consolidate loess samples with the same result as with freshly prepared dispersions.

Properties of Films

Films formed by evaporation of the dispersant are transparent to opaque, with different hardnesses, some soft and some hard. Photo-aging and heat-aging tests on the films showed excellent antiweathering resistance, especially for silicon-modified nonaqueous dispersions.

Consolidation Results

Consolidation properties of the nonaqueous dispersions were tested in the laboratory.

Nonaqueous Dispersion and Clay Samples

The porosity of the loess soil of China is between 40 percent and 53.1 percent. Loess excavated from Changping, Beijing, was crushed and screened, then mixed with water to 9.5 percent by weight water content. The mixture with weights of 310 grams and 270 grams was molded into 50- by 100-millimeter columns with porosity of 41.1 percent and 48.8 percent, corresponding to the upper and lower limits of porosity of this loess.

The solid content of nonaqueous dispersions used to consolidate the loess columns was between 1 percent and 7 percent (table 4). Dispersions with solid content between 0.5 percent and 3 percent showed the best consolidation performance.

Loess samples were saturated with consolidant by capillary rise. Each loess column absorbed 80 to 100 milliliters of nonaqueous dispersion. To fulfill systematic test requirements, 18 columns were made for each kind of dispersion at the same solid content. After two to seven days of evaporation of solvent, saturated loess columns became hard and stable. These were used for testing the consolidation ability of nonaqueous dispersions.

Table 4 Consolidants Used and Their Applied Concentrations

Solid Content	
310 g	270 g
1%, 3%	1%, 3%, 5%, 7%
1%	1%, 3%, 5%
1%	1%, 3%, 5%, 7%

Test Methods and Results

Weight Change. Loess columns consolidated by nonaqueous <3 percent solid content dispersions showed a weight gain of 3 grams or less.

Color Change. Usually the color change was so minimal that it could not be perceived by the naked eye.

Permeability. Permeability of loess consolidated (31J, 21J, and 54J at 1, 2, and 5 percent concentration) samples as determined by immersion in water. It was found that consolidation did not significantly affect permeability.

Rupture Strength. The rupture strength of loess columns consolidated by 31J, 21J, and 54J was determined (table 5).

Water Resistance. Loess columns (270 g) consolidated with 31J, 21J, and 54J (solid content greater than 1 percent) were stable in water without cracking or disaggregation, except for columns consolidated with 21J, more than 5 percent of which failed.

Freeze-Thaw Tests. Freeze-thaw tests (4 hours of immersion in water and 4 hours at -25°C) were conducted. Loess columns consolidated by 31J cracked in the first freeze-thaw cycle, and the crack opened in the next cycles; some columns broke into pieces. Loess columns consolidated by 21J showed good results, except for one column in which particles fell from the surface. Loess columns consolidated with 54J showed good results, except for several in which small cracks appeared.

Salt Resistance Tests. Consolidated loess columns were dipped into 5 percent sodium sulfate solution for 8 hours, then dried at 100°C for 4 hours to complete one cycle. Loess consolidated with 31J cracked and broke into pieces after

Table 5 Rupture Strength of Treated Clay Samples

Solid Content (%)	Rupture Strength (kg)			
	31J	21J	54J	
310 g	0	170	170	170
	1	200	220	316
	3	320	296	
270 g	0	47	47	47
	1	50	70	50
	3	68	100	97
	5	101	137	
	7	127		



FIGURE 1 Consolidation of the dividing wall in pit 1 of the Terracotta Warriors. The front wall is untreated; the rear wall is treated.

three cycles. Loess consolidated with 21J gave a good result, although the sample with solid content of 3 percent developed small cracks after three cycles. Loess consolidated with 54J also developed cracks and the upper part was destroyed after the cycles.

Application Testing on Archaeological Sites

The Terracotta Warriors Site

Small-scale tests of the consolidation effectiveness of nonaqueous dispersions were conducted at several locations at the site of the Terracotta Warriors of the first emperor of the Qin dynasty. Because the results were good, a middle-scale test was conducted on a dividing wall, 15 by 18 by 1.6 meters (length \times width \times height) in pit 1. The surface area was about 45 square meters. 31J consolidant at 2.5 percent concentration was used. Consolidant was sprayed on the vertical surface of the dividing wall repeatedly until the soil was saturated. After application, the area was covered by plastic film for one week in order to avoid rapid evaporation of the solvent. Penetration was about 4 centimeters. The consolidated surface was periodically inspected over three years. The result was good (fig. 1): the surface had little or no color change, and it was so hard that no loss of earth occurred when scratched.

The Yang Mausoleum

The Yang Mausoleum of Emperor Jing (r. 188–144 B.C.E.) of the Western Han is located in Xianyang City, Shaanxi province. The test was done on a wall of the tomb and a wall of the ramp where an imprint of a decayed wooden member occurred. Each area was 60 by 70 centimeters and required 6 and 5 liters, respectively, of 31J at 2 percent concentration. The result was examined after five months and again after two years. The tomb surface was hard but had some color change (fig. 2). The wood imprint was hard; however, the unconsolidated areas showed signs of weathering.

Niuheliang

Niuheliang is a Neolithic Hongshan culture (5000–3000 B.C.E.) site of national significance, discovered in 1981 in Liaoning province. The site has been heavily weathered after excavation. After consolidation testing in the laboratory, two nonaqueous dispersions were used on small (50 by 50 cm) areas. 31J (2% concentration) and 251M (1% concentration) were applied to the top and side surfaces of a dividing wall (an unexcavated earth body). The treated areas were then covered by plastic film so as to minimize the loss of solvent due to wind, which could affect the consolidation. A month later, a depth of penetration of 12 centimeters on the top of the dividing wall and a depth of 8 centimeters on the side of the same wall were achieved with 31J, and a depth of 8 centimeters was achieved on a side wall of 251M.



FIGURE 2 Consolidation of the wall of the Yang Mausoleum. The left side is untreated; the right side is treated.

The Fayuan Temple

The Fayuan temple was built in the late seventh century in present-day Beijing and renovated several times in its history. During restoration work in 2002, rammed earth walls were found in the bell and drum towers of the temple. The decision was made to preserve the walls in the traditional manner, by attaching hemp fiber and then coating them with lime plaster. But it was found that the walls were too weathered to hold the hemp fiber and lime plaster. After testing on small samples, 31J (1.2–1.5% concentration) was applied to the weathered areas. After three days, the treated surfaces were stabilized, and hemp fiber and lime plaster were applied to them.

Conclusion

Nonaqueous dispersions have proved superior to water-based acrylic latexes in several respects. Our laboratory tests showed that they cause insignificant weight and color changes and produce positive results in consolidating soil samples, which were confirmed by field tests.

References

- Campion, R. P., and J. F. Yardly. 1971. Manufacture of polymeric compositions. U.S. Patent 3574161 filed February 28, 1968, and issued April 6, 1971.
- Keown, R. W., inventor. 1973. Manufacture of solutions and dispersions of polymers in organic liquids from a polymer latex. U.S. Patent 3733294 filed November 25, 1970, and issued May 15, 1973.
- Walbridge, D. J., inventor. 1973. Polymer dispersions. British Patent 1305715 filed July 4, 1973, and issued February 7, 1973.

Consolidation Methods for Cracks at the Qin Terracotta Army Earthen Site

Zhang Zhijun

Abstract: After archaeological excavation of the Terracotta Warrior burial pits, the rammed earth walls dried out and developed large structural cracks. This paper reports on stabilization techniques, including the use of steel braces, plates, and rods, and also continued treatments with potassium silicate consolidate. After evaluation the recommended treatment was determined to be rock bolts of sand and lime with propping of cracked walls with steel plates.

In the Qin Mausoleum of the First Emperor, auxiliary burial pits 1, 2, and 3 are large-scale underground structures made of earth and timber. The side and dividing walls of the pits are built of layers of rammed earth, each layer with an average thickness of 10 centimeters. These earthen structures are an integral part of the main burial pit and have important cultural significance.

Some parts of the side and dividing walls had already collapsed before excavation, due to periodic flooding over the centuries. The weight of the 2 to 3 meters of topsoil exerted **pressure on the underlying structures**. After excavation the environmental conditions changed and led to rapid loss of moisture. Consequently, lateral stress relief resulted in fissures up to 10 centimeters wide in the side earthen walls and partitions. A number of long cracks parallel to the side and dividing walls developed, threatening collapse. This situation threatened the site and the terracotta figures between the partition walls (fig. 1). In order to preserve this important heritage site, extensive experimental research on preservation of the earthen structures was carried out.

Consolidation Methods

Five consolidation methods were tried, as follows.

U- and H-Shaped Steel Reinforcement Supports

In 1988 some parts of a dividing wall were about to collapse. U- and H-shaped steel was used to stabilize ten areas of fissuring (figs. 2, 3). The steel was treated with anticorrosion material, and after installation the supports were further treated to blend visually with the earth.



FIGURE 1 Ten-centimeter-wide cracks on the earthen partition wall in pit 1.

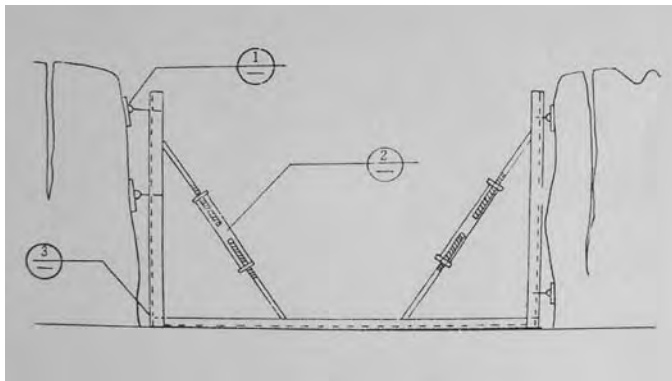

(a)

FIGURE 2 U-shaped bracket for reinforcing the earthen partition wall.



(b)

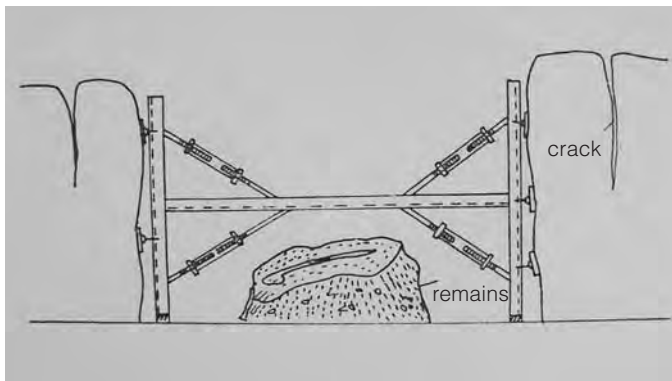

(a)

FIGURE 3 H-shaped bracket for reinforcing the earthen partition wall.



(b)

Wall Stabilization with Steel Plates

In 1991 an additional measure was taken to stabilize the walls. Steel plates on both sides of a wall were secured with a steel bar through the wall and anchored into the ground with cement (fig. 4). Cracks were filled with earth to improve the visual effect (fig. 5). The method was used in parts of pits 1 and 3 instead of the U- and H-shaped steel supports.

Steel Rod Grids

Two large cracks developed on the overhang of the entrance-way to the east wall of pit 1. The cracks ran from the top to the bottom of the wall, and a huge mass of earth was in danger of collapsing. Steel rods were embedded into grooves cut into the earth structure. The rods were tied together with bars penetrating the walls to create a grid. The whole was secured to the ground with cement.

Combined Physical and Chemical Consolidation

Combined physical and chemical consolidation was tested by Li Zuixiong and Wang Xudong of the Dunhuang Academy in 1996. A relatively thin fracture on the northern wall of pit 1 was filled with potassium silicate slurry and anchored with specially made anchor rod and slurry.

Anchor Bolts with Sand and Lime

From 1999 to 2001 a joint Sino-German project used aluminum rock bolts with sand and lime for consolidation of two areas of endangered dividing walls of pits 1 and 2. The equipment, designed especially for the project, was capable of both boring and filling the sand and lime in the holes (fig. 6). The anchor rod was aluminum alloy of 8 millimeters diameter. The mixture was made of 90 percent fine sand (water washed and passed through a 1 mm screen), 5 percent

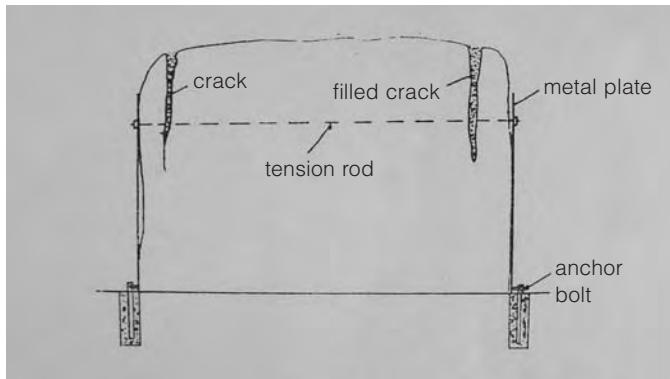

FIGURE 4 Steel plates for reinforcing the earthen partition wall.



FIGURE 5 Condition of the earthen partition wall after use of steel plates for reinforcing. The imprint of steel plates can be seen on the wall.

cement, and 5 percent white lime. The slurry was made with deionized water.

Evaluation of Methods

U- and H-shaped steel supports were effective in preventing collapse but left evident changes in the appearance and also impeded the restoration work of putting the terracotta figures back into their original positions. This method can be justified only when the need is urgent; in general, it is unacceptable for future conservation of the Terracotta Army.

Use of steel plates has the advantages of being a simple, safe technique and of being reliable and durable. It is a useful

method for consolidating the dividing walls, especially when cracks occur on both sides of a wall. But it has drawbacks. Boring through the wall often damages its other side because of the pressure exerted. It is also difficult to drill holes from both sides that will meet each other, since the walls are thick. In addition, securing the system to the ground with cement bricks requires the removal of the original floor bricks.

The steel grid used for the eastern wall of pit 1 also had drawbacks: it damaged the wall surface and affected the appearance. Although this method prevented collapse of huge structural parts, other considerations need to be taken into account for future applications. If it were integrated with a restored wooden structure, as was present originally, such that the appearance was not affected, it could be used.

The combined physical and chemical treatment was satisfactory as an experiment, but the method is difficult to use and to control. The potassium silicate slurry is water based and the shrinkage on drying rather large. This would be likely to cause new cracks. In addition, use of water weakens the earthen structure and adds to the risk of collapse. Therefore, we do not recommend this method, especially as simpler solutions to the problem exist.

Anchor bolts with sand and lime proved most satisfactory. The technique has the advantages of high efficiency, excellent appearance, low cost, and reliability, and it can be used in dry and wet situations. **Compared to the other stabilization methods, in general, it is the best way to conserve the Terracotta Army pits.**



FIGURE 6 Reinforcing with the anchor bolts and grouting method.

Conclusion

Because of the complexity of the existing conditions of the site, more than one type of conservation is required, even when one method is considered the best. We propose the following options for the site: rock anchors with sand and lime, propping up both sides of a wall with steel plates, and improved steel grid frames. The final decision has to be based on the location and condition of the cracks. The U- and H-shaped steel supports, the combined physical and chemical consolidation method, and the unimproved steel mesh frames should no longer be used.

The Conservation Program for the Castle Ruins of the Guge Kingdom in Ali, Tibet

Wang Hui

Abstract: *The Guge Kingdom was one of the regional regimes established in the ninth century by the descendants of the Tibetan Empire in the Ali area in western Tibet. The main castle, which was the center of the kingdom, was located on a hill in Zhaburang (currently Zhada county). The area was abandoned when the regime collapsed in the seventeenth century. Today the site consists of ruins of residences, temples, grottoes, and defensive structures, which occupy an area of nearly 720,000 square meters. From 1996 to 1999 the State Administration of Cultural Heritage provided funding for a conservation project. Conservation technicians from Hebei and Shaanxi provinces and other areas joined the Cultural Heritage Bureau of the Tibet Autonomous Government to implement the conservation project at the site. The author participated in the project for its duration and was in charge of the project's investigation and design. This paper focuses on the working process and technical solutions.*

From 1996 to 1999 China's State Administration of Cultural Heritage (SACH) funded a program to conserve the weathered and endangered cultural heritage sites in Ali, a remote and distinguished region in Tibet. The central government considered this effort a key program to aid the Tibet Autonomous Region. Three main sites were involved: the castle ruins of the Guge Kingdom, the Tuolin Monastery, and the Dongga Piyang Ruins, all of which are on the list of China's designated historic sites. The program, with a total expenditure of more than 10 million RMB (Wang Hui and Pengcuolangjie 2002), was the largest comprehensive conservation effort in Tibet aside from the conservation program of the Potala Palace. The program, which involved not only architectural conservation but also archaeological research,

engaged experts and technicians of diverse ethnic groups from Tibet, Hebei province, Shaanxi province, and Beijing.

This paper discusses the conservation effort for the castle ruins of the Guge Kingdom. The site is located on a hill in the far western section of the Qing-Zang plateau, in a basin between the Himalaya and Gangdise mountain ranges, adjacent to India and Kashmir. Next to the hill the river Langqinzangbu (Xiangquanhe) flows to the north. The altitude of the site is between 3,680 and 3,800 meters above sea level.

History of the Guge Kingdom's Castle Ruins

The historic kingdom of Guge can be traced to the ninth century C.E., following the collapse of the Tubo dynasty. When the king of Tibet was assassinated by a lama in 842, one of his descendants, Jidenimagun, fled to Zhaburang, in the western part of Ali, and was empowered by the local authorities. He married the daughter of the indigenous king and developed the region into a strong realm in western Tibet. After Jidenimagun passed his power to his three sons, the realm was divided into three parts, one of which was called the Guge Kingdom, which occupied the Zhaburang region. The king of Guge and all his successors believed in and promoted Buddhism, and as a result many monasteries were built in the region, near the capital. Among them, Tuolin Monastery was the most prestigious. One of the kings invited an Indian monk, Master Atisa, to reside in the monastery (Su Bai 1996). Because of Tuolin Monastery, Guge became one of the two cradles of the Tibetan Buddhist movement. In the second half of the seventeenth century, weakened by conflicts between different religious groups, Guge was invaded and occupied by the neighboring



FIGURE 1 Guge Kingdom site view.



FIGURE 2 Mountaintop ruin.

kingdom of Ladak. The Guge Kingdom, which had lasted for about eight centuries, came to an end.

The Guge Kingdom's castle was a large complex of buildings that housed the central administration. After the kingdom's collapse, the site was abandoned. The castle ruins cover a 720,000-square-meter area that is 600 meters long east-west and 1,200 meters wide south-north. Major buildings were terraced along the eastern slope of the hill. More than 400 temple buildings, nearly 1,000 grottoes, 58 defense towers, 4 secret passages, 28 pagodas, 11 warehouses, and various accessory houses were documented. All the buildings were made of earth and timber. Currently, only five temple halls are structurally intact; other buildings have either collapsed completely or are partially standing, with only the deteriorated walls extant. Owing to the region's arid climate and the desolate location, the original state of the ruins was preserved (figs. 1, 2) (Xizang gong ye jian zhu kan ce she ji yuan bian 1988).

The earliest on-site survey of the castle ruins was conducted during the 1920s and 1930s by Giuseppe Tucci, a scholar who worked in the Oriental Institute in Italy. In 1961 the State Council designated the Guge Kingdom's castle ruins a historic site of national significance. Beginning in the 1970s, a professional survey of the site was organized.

Planning and Implementing the Castle Ruins Conservation Project

The author was in charge of the investigation and design phases of the project, as chief engineer. Based on the sugges-

tions of experts after their preliminary inspection of the site in 1996, the project team worked out a scientific and orderly procedure and methodology to follow during the conservation process, as follows:

- Staff. The staff comprised architects, engineers, conservators, archaeologists, geographers, and scholars of Tibetan studies. Team members were from different ethnic groups, such as Tibetan, Muslim, and Han. Four professional groups comprising engineering, archaeology, documentation, and liaison were organized, and all tasks were assigned.
- Data collection. This included historical, climatic, geologic, and archaeological information, as well as records or documentation on historical interventions and existing publications.
- Survey. A detailed on-site survey and assessment was conducted, which included recording measurements and mapping and visiting similar sites in the vicinity for reference.
- Applicable technology. Local traditional construction skills, as well as the possibility of applying new technology in the project, were reviewed. Advice and suggestions were solicited from local technicians and monks.
- Final conservation plan. The final conservation plan was drafted and forwarded to Tibetan cultural heritage officials and then to SACH.
- Plan evaluation. Seminars were organized for experts to evaluate the plan for approval.

- Investigation. Archaeological investigation of relevant sites was conducted before any work was undertaken.
- Implementation. Project tendering and implementation of the conservation plan were undertaken, with on-site supervision of the contractor.
- Approvals. Regular checks were made of each project component before the completed work was approved; SACH gave final general approval to the project.
- Maintenance plan. A maintenance plan, including a detailed work schedule, for the site was written. Financial resources were budgeted to carry out the maintenance.
- Project reports. A project summary was prepared, and conservation reports were compiled and edited.

On-Site Survey and Assessment

The hill on which the castle ruins are located is bare of any vegetation, and the geology is of the Quaternary period. The rock is easily cut and eroded by water. Ruined walls were made of either rammed earth or earthen blocks that erode easily. Occasional heavy rainfall (occurring once or twice every July and August, with an average annual rainfall of less than 100 mm) and frequent strong winds are the dominant elements that damage both the hill and the buildings. Other factors, such as uncontrolled accessibility to tourists and local people, also threaten the site.

The main problems at the site relate to water: erosion, cracked and leaning walls, collapsed roofs, and deterioration of walls and indeed of the entire topography required emergency consideration (fig. 3). This paper does not deal with the grottoes and their paintings. It can be noted, however, that extensive damage arising from the loading of buildings above the grottoes with deformation of the cave walls occurred. In many cases, stagnant water accumulated in the decorated caves. In some cases accumulation of soil due to collapsed entrances tended to direct water into the cave interior.

In fact, poor drainage undermines the entire site. As mentioned, the rains are of short duration but heavy. This type of precipitation is especially damaging to urban structures. Originally, the complex had an effective drainage system, and some water outlets are still functioning. After abandonment, debris started to block outlets and resulted in progressive erosion within the ruins.

Conservation of the Castle Ruins

The walls that remain standing on the site of the Guge castle are uniquely picturesque and embody the history and evolution of the castle complex (fig. 4). Therefore, maintaining the ruins in their present condition was important. Eliminating all causes of damage was unrealistic. We worked out a practical conservation plan that emphasized reinforcing at-risk sections and improving stability of especially important parts of the ruins. Repair and reinstatement of the drainage system to reduce the effects of water were key interventions. The final goal of the conservation project was to minimize deterioration and preserve the ruins as a whole.

The philosophy and principles guiding the design and implementation of the conservation effort were based on the heritage conservation law of China and relevant national charters and recommendations. The following points were key:

- Consolidation and engineering interventions were kept to a minimum. The visual effects of interventions were as inconspicuous as possible, and all additions were compatible with the fabric of the site.



FIGURE 3 Cracking and threatened collapse of earthen architecture.



FIGURE 4 Building foundations and the mountainside eroded by rainwater.

- The interventions had to be reversible. Since most parts of the site were not excavated, it was necessary to minimize the disturbance of debris and deposits to preserve the site as far as possible.
- Local materials and the traditional skills of the local population were employed to the extent possible.

Project Details

Specific work to conserve the castle ruins is described below.

1. Standing walls:
 - Severely deteriorated blocks or lost parts were replaced.
 - Earthen walls suffering from vertical cracks were capped and wood lintel timbers inserted to bridge vertical flaws.
 - Leaning walls were buttressed, and rubble was inserted at the base of the buttresses to protect the earthen walls from erosion.
 - Caves with structural cracks were stabilized with support columns painted black to blend in with the surroundings.
 - Missing roof slates were replaced.
2. Upgrading to alter and control water drainage:
 - Decreasing the water retention time on the site and flow distance and allowing water to escape as

quickly as possible were key factors. Retrofitting water outlets was achieved by reducing the number of outlets at the edge of the hill and consolidating large outlets with erosion-resistant materials (fig. 5).

- The topography of the site was modified by partial filling and excavation to reduce water pooling.
 - Dikes or ditches were constructed along sensitive areas to control the water flow direction and to avoid water flow to architectural ruins.
 - Small water outlets were blocked with rubble and mortar to direct water to larger outlets.
 - Timber roofs were added, and holes were filled with clay to exclude water.
 - Large flat areas were paved and drained.
 - Pipes were added to the site to remove water.
3. Roofs: New roofs in the Tibetan style were added to extant buildings to prevent rainfall from affecting wall paintings and entering lower caves. The appearance of these roofs is consistent with the site's setting. Damaged roofs were restored in accordance with evidence discovered from investigation or archaeological work (fig. 6).
 4. Intact halls: Intact halls, such as the White Hall, the Red Hall, and the Daweide Hall, were repaired in a simple fashion with little alteration. Tibetan



FIGURE 5 Drainage system.

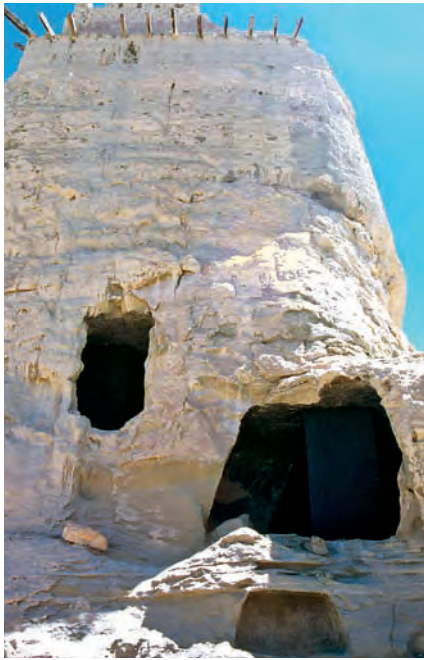

FIGURE 6 Ruin stabilization and support.

architecture is distinguished by the use of Bianma straw decoration on the top of parapets. During conservation of the halls, some lost Bianma straw was reinstated and cracked rafters and decayed roof boards above rafters replaced, and clay was used to seal leaking roofs.

5. Other projects: A five-bay house in traditional Tibetan style was constructed near the site to accommodate the on-site custodians. A special pathway for visitors was paved with local slate. In addition, presentation and information were provided in some places on the site.

Conservation Results

In 1999, after years of arduous work, the project to conserve the castle ruins of the Guge Kingdom was successfully completed. The original character of the site and the sense of a desolate landscape were preserved, and minimum intervention was the underlying policy. Most important, dangerous conditions at the site were eliminated or mitigated. Meanwhile, new discoveries were made during archaeological work that filled gaps in the historical information on the site.

In June 1999, after three days of on-site evaluation and verification, the project was approved by an expert panel organized by SACH. The panel commented, “The original situation of the site and buildings were well respected during design and implementation. The critical causes of deterioration were restrained or eliminated on completion of the project. The expected aim and target were achieved through feasible and practical planning and careful construction” (SACH, PRC, and Ali Area 1999).

References

- State Administration of Cultural Heritage (SACH), PRC, and Ali Area Cultural Heritage Emergency Intervention Project Team. 1999. Emergency intervention results assessment report on ruin sites, Tuolin Temple, Dongga Piyang site in Ali Area, Tibet. Archival document in Bureau of Cultural Relics, Tibet Autonomous Region, People’s Republic of China.
- Su Bai. 1996. *Zang chuan Fo jiao si yuan kao gu = Archaeological Studies on the Monasteries of Tibetan Buddhism*. Di 1 ban ed. Beijing: Wen wu chu ban she.
- Wang Hui and Pengcuolangjie. 2002. *Xizang Ali Diqu wen wu qiang jiu bao hu gong cheng bao gao*. Beijing: Ke xue chu ban she.
- Xizang gong ye jian zhu kan ce she ji yuan bian. 1988. *Guge wang guo jian zhu yi zhi*. Beijing: Zhongguo jian zhu gong ye chu ban she: Xin hua she dian Beijing fa xing suo fa xing.

PART NINE

Mogao Grottoes Cave 85 Project



Objectives of the Cave 85 Project

Neville Agnew and Li Zuixiong

In 1996, after the first phase of collaboration between the Dunhuang Academy and the Getty Conservation Institute, followed by independent review of the successes and shortcomings of the work undertaken beginning in 1989, it was jointly agreed to address the problems of deterioration of wall paintings at the Mogao Grottoes and their conservation by a systematic and methodological process. Cave 85 was chosen for this purpose, and it was further decided that an extensive phase of research and testing would precede any intervention. Moreover, among the objectives of the project were **training and dissemination of the results, particularly** in the northwestern regions of China where similar sites and conservation problems are widespread. At the same time a collaborative relationship was established between the State Administration of Cultural Heritage of China, the Getty Conservation Institute, and the Australian Heritage Commission for the development of national guidelines or principles for heritage sites in China. These principles, issued by China ICOMOS in 2000, base conservation decisions, processes, and implementation on a site's cultural values and significance. The China Principles were used as the guiding precepts in the cave 85 project.

The papers that follow cover many, but not all, of the results and outcomes of the project. First, they reflect the methodology of the China Principles by following a sequence of bibliographic research, development of a significance statement, condition documentation, investigation and analysis of original materials and techniques, study of causes of deterioration, environmental monitoring, and testing—all undertaken before treatment was decided on. Some of the steps were done sequentially, others in parallel where expedient to do so. Before treatment began, a panel of experts convened

by the State Administration of Cultural Heritage reviewed the proposal. Coauthored papers reflect the collaborative nature of the project.

It would be unwise to state that all is now understood about the many afflictions seen in cave 85, or indeed at Mogao itself. The original materials and techniques that were used to create the art are complex, and the deterioration has occurred over many centuries and at different rates. More needs to be known about the art, in greater depth. Progress has been substantial, however. The cave 85 project led to an understanding of many technical problems of wall paintings applied to earthen plaster; detachment or separation of the earthen support from the underlying conglomerate rock; the nearly ubiquitous salts; flaking and disruption of the paint layers by deliquescent salts; migration of these soluble salts from the rock body under the influence principally of water vapor; binding media research; and importantly, the development of compatible materials for treatment. In tandem, the direct impact of visitors on the cave's environment was evaluated, as was the intrusion of air from the outside when the doors were opened. This research in turn formed part of a much larger effort to determine the safe visitor capacity of the site.

Questions remain: What is the nature and origin of the organic colorants used in many areas as washes over mineral pigments, apparently to create a subtle effect? Why in some instances is there analytical evidence for carbohydrates as well as protein in the binding medium? What is the contribution of atmospheric moisture compared with that of humidity emanating through the rock body? Debate will lead eventually to comprehensive and irrefutable understanding of these questions, which also

suggest future research for the Conservation Institute of the Dunhuang Academy to undertake.

Arising from the cave 85 project has been a significant initiative—the master's degree course at Lanzhou University with specialization in wall painting conservation. A collaboration of the Dunhuang Academy with the Courtauld Institute of Art and the Getty Conservation Institute, the course has now graduated its first four students, all staff members of the **Dunhuang Academy**. **These professionals** will be the core of a new generation of conservators at

Mogao whose influence will spread far beyond the confines of the site.

Finally, archives of the data (analytical, environmental, testing, and treatment, photographs and reports) from the cave 85 project are being kept by both the Dunhuang Academy and the Getty Conservation Institute for future access by conservators, researchers, and educators. An extensive report on the project is planned for publication (limited hard copy, as well as an electronic version on the Getty's Web site) in 2010.

The Significance of Cave 85

Wang Jinyu

Abstract: *Understanding the significance of a site is key to its conservation, management, and use. Cave 85 at the Mogao Grottoes, which was completed in six years (862–67 C.E.), is known for its unique historic, artistic, and scientific values. It has seventeen large illustrations of sutras, fourteen of which are in the main chamber. These are mainly related to Buddhist doctrines and daily life in the late Tang period. Certain new styles of painting that are found for the first time in cave 85 show Tibetan, central Chinese, and Dunhuang influences. The paintings and their inscriptions provide information on architecture, transportation, customs, musical instruments, weaponry, tools, and pottery. They also pose useful research questions, such as about the techniques and materials used and their source.*

In 848 Zhang Yichao, from an important Dunhuang family, evicted the Tibetans and recovered territory in the Hexi area that had been occupied by Tibet for years.¹ Later, he asked his brother, Zhang Yitang, to lead a delegation to present a map of the Hexi area to the Tang emperor Xuanzong to demonstrate his willingness to return the area to China and thus support the unification of the country. The emperor rewarded the family for their loyalty and brave actions. In 851 he appointed Zhang Yichao prefect of the eleven states of the Hexi Corridor (Gansu province) and awarded him the title Commander General of the Return to Allegiance Army, stationed at Shazhou (present-day Dunhuang). This led to greater influence and power in the area, and the Silk Road between Gansu and northern Xinjiang (about 1,000 km) again flourished. The Zhang family continued to expand their influence by using their authority and financial resources to build caves at the Mogao Grottoes, including caves 9, 12, 85,

94, and 138, which commemorate the family's meritorious deeds (Ma De 1996).

According to the Hong Bian Stele, dated to the Tang dynasty and located on the west wall of cave 17, Zhang Yichao's action was supported by a Tibetan high monk-official, Hong Bian. After the eviction of the Tibetan regime, Hong Bian was asked by Zhang to send one of his disciples, Wuzhen, with the delegation to the Tang emperor. The emperor favored Hong's loyalty and filial piety and granted him honorific titles (Li Yongning 1981). Therefore, Buddhism, which was already deeply rooted at Dunhuang, prospered with the support of Zhang's family and the imperial order from the emperor. Nearly one hundred caves were restored and constructed during the period of sixty-six years in the late Tang. During Zhang Huaishen's regime, the Dunhuang area was stable and prosperous, with a strong military that made possible the construction of large caves. Zhang Huaishen was also the first high-ranking official to construct caves to demonstrate his wealth, political authority, and social status and that of his family.

Historical Significance

Cave 85 was constructed between 862 and 867 (He Shizhe 1980), an unusually short time. The highest regional monk-official, Zhai Farong, built the cave to demonstrate his political achievements and family wealth, a practice common among many monks and secular officials of the time. Zhai died in 869, about three years after the cave was completed. The cave, known as the Zhai Family Temple, was managed by Zhai's family (Bibliothèque nationale 1994; Wu Mangong 1959).

Cave 85 contains a wealth of art, as well as information on religious practices and daily life. The main chamber alone houses fourteen illustrated sutra paintings, one of the richest collections at the Mogao Grottoes. However, the antechamber has been damaged, making it impossible to determine the original layout.

The wall paintings at Mogao have some non-Buddhist depictions. First, the portraits of donors were prominent and reflect the influence of the region's rich and powerful leaders, especially the Zhang family, which had both political and religious influence. They controlled temples, contributed to the construction of family caves, such as Zhai Farong's, and painted portraits of family members as donors on the walls of cave corridors and at the lower portion of the east, south, and north walls (fig. 1). The portraits of main donors were life-size, and donors included grandparents and grandsons, uncles and nephews, in-laws, and servants painted in sequence. Toward the end of the Tang dynasty, the titles, rank of nobility, and official position of donors were described in great detail in the inscriptions. Thus these portraits were used for secular purposes. Cave 85 is one of the early caves showing this practice.

Portraits of the original donors remaining on the north wall of the cave 85 corridor include remnant inscriptions indicating Farong, his brother Chengqing, and Chengqing's sons, Huaiguan and Huaien (Ma De 1989). The portraits and inscriptions are consistent with the information from the Zhai family stele. Based on Library Cave Manuscript P.3720,



FIGURE 1 Portrait of Zhai Farong, monk-official and donor, on the north wall of the corridor.

the Zhai family stele was erected in front of cave 85. The stele was lost, but a copy of its inscription was preserved in the Library Cave.

Cave 85 is a typical family cave whose owners and donors were different at different periods. Portraits of Zhang Yichao, Zhang Huaishen, and, later, Cao Yijin and his son were painted on the corridor walls. Zhang Yichao and Zhang Huaishen were the regional highest administrative officials during the period of cave construction, and Cao Yijin and his son were the highest administrative regional officials during the period of cave restoration. During the regime of the Return to Allegiance Army, the highest regional administrative official was the main donor of his own cave but served also as honorary principal donor for caves constructed by others during and after his term. Therefore, the large caves constructed or restored at that period always had two portraits of the highest officials, current and former ones. Cave 85 was the first such cave.

Cave 85 was restored once during the Five Dynasties (907–60), and the portraits of donors on the south wall of the corridor and at the north side of the east wall in the main chamber were painted during its restoration. Cao Yijin was the leader of the Return to Allegiance Army at Guazhou and Shazhou, and his portrait and that of his son were painted on the south wall of the corridor. Based on the inscription, the fifth portrait at the north side of the east wall depicts Cao's eldest daughter. Her portrait also appears in cave 98, and the inscription indicates she married into Zhai's family and died before cave 98 was completed. Cave 85 was restored before the Tang dynasty emperor Tongguan's reign (923–25), and the people who restored cave 85 were grandchildren of Huaiguan and Huaien.

Artistic Value

Zhang Yichao evicted the Tibetans and recovered the Hexi area, thereby maintaining the integrity of Tang territory and reestablishing communication between western and central China. This historical incident and geographic setting helped to create the unique grotto paintings at Mogao, which display a combination of influences from central China, Tibet, and Dunhuang. These influences are reflected in the wall painting in cave 85.

The grotto arts at Mogao, as developed between 848 and 906 C.E. during the sixty-six-year Return to Allegiance Army regime, were based on High Tang and Middle Tang (Tibetan) art. Wall paintings in caves 9, 12, 14, 17, 85, 156, and

196 were outstanding and had not been seen before. Wall paintings illustrating the Redemption from Indebtedness and Lankavatara Sutras in cave 85 were among the masterpieces of late Tang arts and reflect also a Tibetan-influenced local style that had been popular for about two hundred years (Shi Weixiang 1985). Thus, as a representative of late Tang paintings at the Mogao Grottoes, cave 85 has very high artistic value.

Artistic Content

Cave architecture, wall paintings, and statues constitute a comprehensive style of grotto arts. By far the majority of wall paintings relate to Buddhism. Using paintings to relate a Buddhist parable is called narrative illustration,² and cave 85 has seventeen such large-scale paintings. Although this type of painting can be seen in other caves at Mogao, the paintings in cave 85 are done in great detail in the new style of the late Tang. A combination of lions and lotus flowers pattern was painted on the coffer (central ceiling panel) in the main chamber. Three layers of unusual decorative patterns surround the coffer, and valance patterns were painted around these. There are fourteen narrative illustrations of sutras on the four ceiling slopes and four walls of the main chamber. Depictions of the Lankavatara, Lotus, Maitreya, and Avatamsaka Sutras were painted on the east, south, west, and north slopes, respectively (fig. 2). The self-sacrifice story from

the Suvarna-prabhāsa Sutra was painted on the east wall above the doorway. The other stories from the Suvarna-prabhāsa and Vimalakīrti-nirdeśa Sutras were painted at the north and south sides of the doorway on the east wall, respectively. The stories of the *Bao'en Jing* (Redemption from Indebtedness), Amitabha, and Diamond Sutras were painted from the east side to the west side of the south wall, respectively. The stories from the Vishechachinta Brahma, Bhaishajyaguru (Medicine Buddha), and Ghanavyuha Pariprichcha Sutras were painted from the east side to the west side of the north wall, respectively. A depiction of Raudraksa battling with Sariputra is painted on the west wall. The sutra of the Wise and Foolish was depicted frame by frame on the lower south, west, and north walls. A partial depiction from the Yuan dynasty of the Manjusri and Samantabhadra Sutras paintings remain at the north and south sides of the west wall in the antechamber, respectively. The ceiling of the corridor has the thousand buddha motif from the Bhadrakalpika Sutra, and both the south and north slopes are adorned with fourteen auspicious symbols. Twenty-six figures, including late Tang monks, male and female donors, and servants, were painted on the south and north walls of the corridor and at the lower part of the east wall in the main chamber. Heavenly kings were painted on the east side of the platform. Paintings of stories representing different sects of Buddhism are scattered around the cave. The complicated compositions and rigorous execution of the paintings offer a splendid visual effect.



FIGURE 2 Ceiling painting pattern and paintings on the east, west, and south slopes (the south slope is the illustration painting of the Saddharmapundarika Sutra).

Unique Characteristics

The main chamber has fourteen narrative illustrations from a number of sutras. For example, the source of the painting of Raudraksa's Battle with Sariputra, which occupies the entire west wall of cave 85, was seventy-three volumes of sutras. Actually, this painting had already appeared during the Northern Zhou and Sui dynasties but did not reappear until the High Tang and the Tibetan regime. The eviction of the Tibetans by Zhang Yichao in 848 C.E. ended seventy years of subjugation for the people of the Hexi area. Using an entire wall to paint the sutra story of Raudraksa's Battle with Sariputra was a way to express the thoughts, feelings, and ideology of this formerly oppressed people through religious painting. The "righteousness overcomes evil" theme reflects their victory and their happiness about the return of Tang territory. People also used the sutra story of Redemption from Indebtedness to express their loyalty to the Tang

emperor. Consistent with Buddhist custom, the painting is located at the east side of the south wall, the right side being the supreme position. Although the narrative illustration still followed the tone of the middle Tang (Tibet), it revealed a strong national consciousness. For instance, the Tibetan princess Zhanpu was a leader of princesses from all nations in the narrative illustration of the Vimalakirti-nirdesa Sutra, which was painted during the middle Tang, but later the Tibetan princess was eliminated from the painting, as were Tibetan costumes.

In addition, cave 85 has more narrative illustrations from rarely depicted sutras, such as the Diamond, Suvarna-prabhasa, Lankavatara, Vishechachinta Brahma Pariprichcha and Ghanavyuha Sutras, than any other cave at Mogao. For instance, the depiction of the Prince Kalyanamitra *jataka* story, from the Redemption from Indebtedness Sutra, on the middle of the east part of the south wall consists of seventeen scenes, and the *jataka* story of the golden hair lion from the same sutra on the upper east part of the south wall has seven scenes (Li Yongning 1982). In addition, cave 85 has the largest number of inscriptions from the illustrated Lankavatara Sutra. A unique one is the pictorial representation of the sutra of the Wise and Foolish, which was illustrated scene by scene at the lower part of the south, west, and north walls in the main chamber. Among them, about twenty new stories are mentioned; a few, such

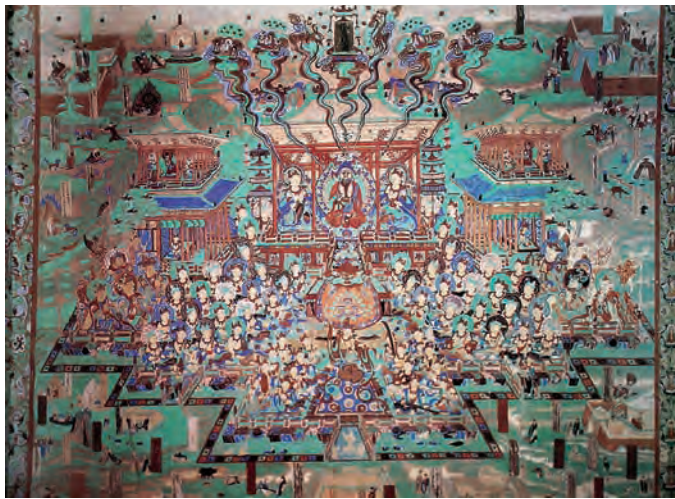

FIGURE 3 Painting of the Redemption from Indebtedness Sutra on the east side of the south wall.

as the sea god testing the boatman, the story of Gangata presenting seven treasures to the Buddha, the story of the Vajra-devas, and that of Sandanika appear for the first time in the wall paintings at the Mogao Grottoes.

Secular Influences

Portraits of donors are among the examples of the strong secular influences. In addition, daily living, common customs, and life stories were depicted; for example, the horse stable in a courtyard and fighting on both sides of a river from the parable of the children in the burning house in the Lotus Sutra (see fig. 2) on the south slope.

Other examples of secular influence in the narrative illustrations are Raudraksa battling with Sariputra, from the story of the Buddha overcoming demons, and Prince Kalyanamitra playing a musical instrument under trees (figs. 3, 4), from the Redemption from Indebtedness Sutra. The wedding scenes in the illustration of the Maitreya Sutra, including guests being hosted in a reed pavilion, the bride and bridegroom kneeling for the ritual, and the carrying of torches, are not only interesting but also depicted for the first time in cave 85 (Li Yongning and Cai Weitang 1990). Pictorial representation of the Lankavatara Sutra relied on scenes from daily life such as farming, eight people carrying a sedan chair, butchers, hunters, pottery making, weighing pork, looking into a mirror, and an acrobatic performance (fig. 5).



FIGURE 4 Section of the painting of the Redemption from Indebtedness Sutra, *jataka* story of the prince Kalyanamitra, playing a musical instrument (*zheng*) under the trees.



FIGURE 5 Painting of the Lankavatara Sutra on the east slope.

The use of framed narrative illustrations started in the high Tang. In the middle Tang these framed illustrations were used to elaborate the sutra story depicted on the ceiling panel. By the late Tang, the subject of these pictorial representations was no longer related to the painting shown above them. In cave 85, fifteen of these framed paintings from the sutra of the Wise and Foolish, located at the lower part of the south and north walls, are not related to other paintings. In the middle and late Tang, these framed paintings were used by monks as a visual aid in teaching and to help believers understand the doctrines. Compared to the framed narrative paintings, the narrative illustrations on the ceiling slopes depict the Buddha, disciples, bodhisattvas, and angels and are in a strict and sequential arrangement; framed didactic illustrations are less strictly ordered than are formal sutra narratives. The contrast between the two types of paintings is marked. For instance, the framed depiction of the Wise and Foolish Sutra has more secular than religious figures, and both costumes and scenes reflect the daily life of the Shazhou region at the time. Thus these illustrations also provide information on the local social life and were easier for people to enjoy, being dramatic and entertaining. This type of painting also gave artists more freedom and space to paint in a new way.

Diverse Styles

The composition and styles of the illustrated sutra story paintings in cave 85 essentially followed earlier patterns, but their overall layout, figure selection, story content, and scenarios represented a new breakthrough. For instance, the narrative illustration of the Redemption from Indebtedness Sutra is one of the highest in artistic value at Mogao. At the center of the painting are the Buddha and holy people; above

the Buddha and the colored cloud is an inscription of the story. The lower central part is a preaching scene, which is a preamble to the story. All the major stories of each chapter are located at the lower part and four corners. The painting uses several perspective approaches. All people and activities in the painting can be seen clearly. Each corner has its own story, but all stories are closely related, with detailed elaboration.

The wall paintings in cave 85 have other unique aspects, such as the arrangement of scenes and the design of figures. The illustration of Raudraksa battling Sariputra is one of the most unusual; unfortunately, most of the painting has been lost. The composition of the Redemption from Indebtedness Sutra is special; its figures are vivid, with two lovers sitting and talking face-to-face under trees and playing a musical instrument. All secular people in the illustration of the Lankavatara Sutra are full of energy. For instance, the butchery scene (fig. 6) shows the active life of ancient times.

In summary, the wall painting art in cave 85 was developed based on previous achievements, but it lost some degree of the sincerity and heavenliness of earlier Buddhist art. However, there were many innovative approaches showing daily life of people. The wall paintings in cave 85 are truly masterpieces.

Scientific Value

The wall paintings in cave 85 provide information on the history and development of science and technology in the late ninth century. In addition, many of the inscriptions, entirely



FIGURE 6 Scene of a slaughterhouse from the painting of the Lankavatara Sutra.



FIGURE 7 Painting of the Vishechachinta Brahma Pariprichcha Sutra on the east side of the north wall.

faded, can now be read using modern scientific examination techniques. The cave is, moreover, a good case study for Tang dynasty wall painting techniques and pigment sources. Pigment color change and the plant dyes and binding media used and their aging are important research subjects today.

Conclusion

Cave 85 has preserved seventeen large-scale narrative illustrations and other paintings. The depictions consist of doctrines, laws, articles, and the history of Buddhism, as well as sutra stories. The motifs also include figures of deities, illustrated sutra stories, architecture, auspicious symbols, animals, decorative patterns, and donors (in about eight categories). They provide insight into the life of ordinary people and feudal society's history, culture, politics, economy, science and technology, military, religion, architecture, transportation, costume, music and dance, and folklore. They are not only representative of Tang dynasty painting and polychrome statuary, but they also constitute a pictorial history of the Tang dynasty (figs. 7, 8).

Acknowledgments

The author expresses his gratitude to Peng Jinzhang, former director of the Archaeology Research Institute, Dunhuang



FIGURE 8 Painting of the Bhaishajyaguru Sutra on the north wall.

Academy, for his kind review of the Chinese content of this paper; and Po-Ming Lin for the translation.

Notes

- 1 Sanskrit terms in this paper come from W. Soothill and L. Hodous, eds., *A Dictionary of Chinese Buddhist Terms* (Chippenham, U.K.: Antony Rowe, 1937).
- 2 *Jingbian* in Chinese. This term has been translated as “sutra transformations” and “tableaux” by other scholars. See Murray 1994.

References

- Bibliothèque nationale de France. 1994-. *Faguo guo jia tu shu guan cang Dunhuang Xi yu wen xian = Tibetan Documents from Dunhuang in the Bibliothèque nationale de France*. Dunhuang Tulufan wen xian ji cheng. Shanghai: Shanghai gu ji chu ban she.
- He Shizhe. 1980. [The collation of inscriptions of attendants on wall paintings at the Mogao caves]. *Zhongguo shi yan jiu = Journal of Chinese History Research* 3: 25–42.
- Jin Weiruo. 1959. [Study of the names and quantity of caves and niches at the Mogao Grottoes]. *Wen wu* 5: 50–54, 61.
- Li Yongning. 1981. [The compilation of inscriptions on stelae at the Mogao Grottoes and their problems]. *Dunhuang Studies* 1: 56–79.

- . 1982. [Sutra of Redemption from Indebtedness and its illustration painting on Mogao wall painting]. In *Dunhuang yan jiu wen ji = Special Collection of Dunhuang Research*, 189–219. Lanzhou: Gansu ren min chu ban she: Gansu sheng Xin wu shu dian fa xing = Gansu People's Publishing House.
- Li Yongning and Cai Weitang. 1990. [The illustration painting of the Amitabha Sutra on Mogao wall painting]. In *Dunhuang shi ku yan jiu guo ji tao lun hui wen ji = Proceedings of the 1987 International Conference on Research on the Dunhuang Grottoes*, 247–72. Shenyang Shi: Liaoning mei shu chu ban she = Liaoning Arts Publishing House.
- Ma De. 1989. [The family caves of monk officials and their construction]. *Dunhuang Studies* 4: 54–58.
- . 1996. [*Research on the History of the Mogao Grottoes at Dunhuang*]. Lanzhou: Gansu jiao yu chu ban she = Gansu Education Press.
- Murray, J. K. 1994. The evolution of Buddhist narrative illustration in China after 850. In *Latter Days of the Law: Images of Chinese Buddhism, 850–1850*, ed. M. Weidner. Lawrence, KS: Spencer Museum of Art.
- Rong Xinjiang. 1989. [Some issues during the Shazhou Returned Righteous Army regime]. *Dunhuang Studies* 4: 70–78.
- Shanghai Classics Publishing House and French National Library, eds. 2005. *Dunhuang and Other Central Asian Manuscripts in the Bibliothèque Nationale de France*. No. 32.
- Shi Pingting. 1990. [Research on illustration painting of Suvarnaprabhasa Sutra]. In *Dunhuang shi ku yan jiu guo ji tao lun hui wen ji*, ed. Duan Wenjie, 2:414–55. Shenyang Shi: Liaoning mei shu chu ban she = Liaoning Arts Publishing House.
- Shi Weixiang. 1985. [*Splendid Dunhuang Wall Paintings: Tang, Five Dynasties, Song, Western Xia, and Yuan Dynasties Wall Painting Arts at Mogao and Yulin Grottoes*]. Chinese Arts Corpora, no. 15, 1–22. Zhongguo mei shu quan ji: Hui hua bian, nos. 14–15. Shanghai: [People's Arts Publishing House].
- Wang Jinyu. 2003. The mysteries of the source areas of pigments used on Mogao wall paintings. *Sciences of Conservation and Archaeology* 25 (2): 47–56.
- Wu Mangong. 1959. [Arrangement for lighting lanterns in caves and niches on December 8 (lunar calendar) at the Mogao Grottoes]. *Wen wu* 5: 49.

Conservation History and Condition Survey of Cave 85

Xu Shuqing, Wang Xiaowei, Sun Hongcai, Li Weitang, Francesca Piqué, Lorinda Wong, Leslie Rainer, and Zheng Jun

Abstract: Cave 85, containing more than 300 square meters of painted surface, was excavated and decorated in the late Tang dynasty. The Dunhuang Academy began work in this cave in the 1950s, filling large plaster losses at the base of the walls and at the rear of the cave. Flaking and disruption of the wall paintings were treated in the 1970s with a mixture of polyvinyl alcohol (PVA) and polyvinyl acetate (PVAC) emulsions. At that time, areas of plaster detachment were also secured to the conglomerate with rock bolts. However, by the late 1980s and early 1990s, flaking and disruption had recurred on the west end of the cave, and new areas of plaster loss, through collapse, were visible. These phenomena were associated with periods of high humidity, due primarily to rain events at the site, in an otherwise dry climate and the presence of soluble salts. At the beginning of the Dunhuang Academy–Getty Conservation Institute collaborative project, the conservation history of the cave was reviewed and a condition assessment undertaken. A bilingual illustrated glossary that describes categories of deterioration was developed to ensure a common vocabulary for the project and for the site. The main deterioration problems recorded in cave 85 in 1998 included flaking, exfoliation, plaster disruption, and plaster detachment. The condition assessment showed that active deterioration is most pronounced and widespread over the entire west end of the cave. This, together with environmental monitoring and the analytical investigation to map salt distribution within the cave, was essential for the diagnosis of the causes of deterioration.

In the 1950s the Dunhuang Academy (then the Dunhuang Cultural Relics Research Institute), following a series of comprehensive surveys of the site, began a full-scale stabilization project at the Mogao Grottoes. Earth and straw

plaster repairs were used to fill losses of the wall paintings that had occurred over the centuries. In the 1970s the flaking paintings were treated with polyvinyl alcohol (PVA) and polyvinyl acetate (PVAC) emulsions, and areas where painted plaster had detached from the underlying rock conglomerate were anchored with steel rock bolts and cross-braces. But by the 1980s and early 1990s flaking and plaster separation problems had returned in a number of the caves, including cave 85. For this reason, cave 85 was selected by the Dunhuang Academy (DA) and the Getty Conservation Institute (GCI) as a project for the application of the China Principles methodology for the conservation and management of sites (formally, the *Principles for the Conservation of Heritage Sites in China*).

As described in the China Principles, the protection of historic and cultural sites should follow a methodological approach (see Piqué, Wong, and Su Bomin, this volume) that includes, as a preliminary step, the investigation and recording of both past and current conditions of the wall paintings and the establishment of a history of interventions. This background information is fundamental to understanding the causes and mechanisms of deterioration affecting the site today in order to develop, test, and implement appropriate preventive strategies and stabilization treatments to ensure long-term preservation.

Physical and Conservation History

Cave 85 lies at ground level to the north of the Nine-Storey Pagoda (cave 96). It is adjacent to cave 86 to the south and cave 84 to the north; caves 242 and 243 are on the tier above (fig. 1). The cave was created between 862 and 867, during the

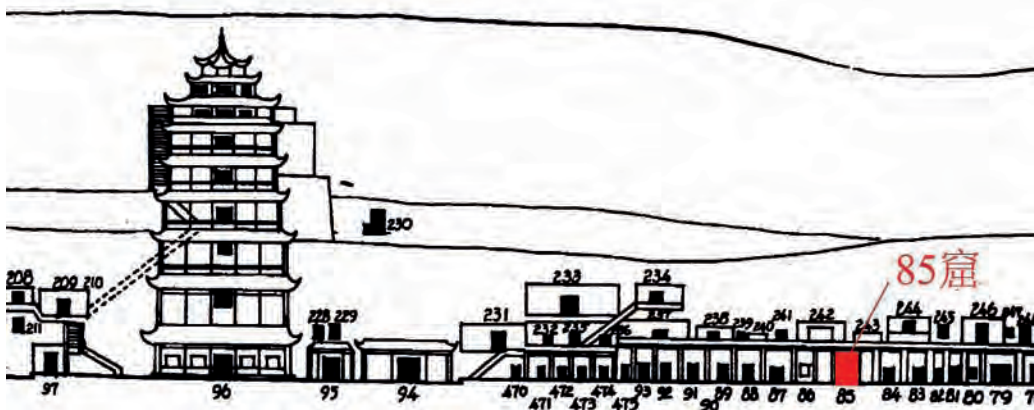

FIGURE 1 The location of cave 85.

late Tang dynasty. Later, in the Five Dynasties period and the Yuan dynasty, the entrance and corridor walls were redecorated. It is one of the larger caves at Mogao, with 316 square meters of painted plaster extant. The cave is divided into three parts: antechamber, corridor, and main chamber (fig. 2). The ceiling of the main chamber is in the shape of a truncated pyramid; and there is a large altar with three sculptures in the main chamber. Before it was given its current designation, the cave was referred to as C60 by Zhang Daqian,¹ as P092 by Paul Pelliot,² and as cave 129 by Shi Yan (Shi Zhangru 1996: 104–6).

In the 1950s large-scale plaster repairs were carried out on the lower part of the four walls of the main chamber, part of the west wall, the lower part of the south and north walls of the corridor, and the upper and lower parts of the west and north walls of the antechamber. In 1957 and 1958 reinforcement work of the cliff face was started in the zone of caves 78–93 on the ground level, which includes cave 85, and caves 237–48 on the second tier.³ Pillars of stone and bricks were built up to support a new facade to protect the cliff face and to accommodate stairs and walkways (fig. 3). At this time, the floor of cave 85 was paved with concrete.

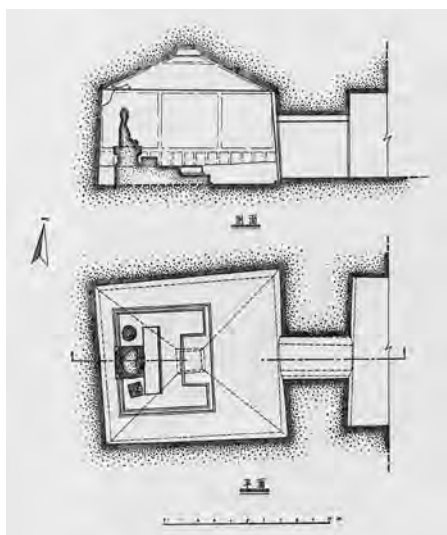

FIGURE 2 Cave 85 in plan and section. The cave is divided into three parts: antechamber, corridor, and main chamber.



FIGURE 3 Cave 85 during construction of facade and walkways (1957–58). Pillars were built in front of the cave to support a wooden walkway and provide support to the fronts of caves 242 and 243.

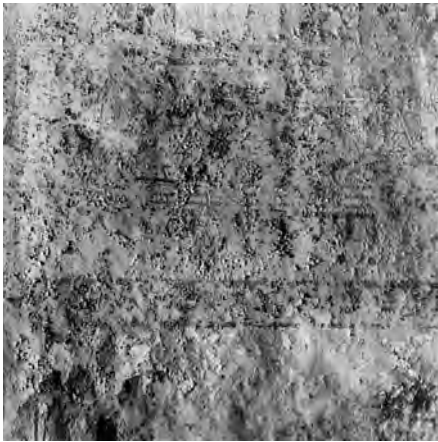

FIGURE 4 Flaking on the east wall of cave 85 (1973).

Archaeological excavation revealed that there were two periods of platform remains that once supported the cave 85 temple front (Pan Yushan, Ma Shichang, and Dunhuang wen wu yan jiu suo 1985: 22–26). The lower, larger platform was built in the Five Dynasties, while the upper platform was built on top of this as a renovation of the cave temple front during the Yuan dynasty.

A condition survey undertaken in cave 85 in 1973 showed that flaking of the paint layer was a serious problem on the southern and northern parts of the east wall of the main chamber (fig. 4), as well as toward the rear, west end of the cave, including the west wall and ceiling slope and western ends of the south and north walls and ceiling slopes. As a result, in 1974 a wooden entrance door to the cave was installed, and 186 square meters of flaking paint and separated plaster were treated. An aqueous mixture of PVA (1.5%) and PVAC (2%) was used as an adhesive in a ratio of 4:1 by volume (Duan Xiuye and Sun Hongcai 1990: 92–94). The adhesive was first injected behind the flakes and then gently pressed back and relaid with brushes and cotton balls. After this operation, PVA (2%) and PVAC (3%), in a ratio of 4:1, were sprayed on to consolidate the surface.

The detached paintings were pinned with two different kinds of anchors (or cross braces), one made of steel (fig. 5) and the other made of poly(methylmethacrylate) or acrylic glass. Steel anchors were used throughout the cave, one on the northern part of the east wall, two on the west wall (the upper parts of the north and south ends), and five in the corridor; two acrylic glass anchors were used on the eastern part of the north wall. The anchors were soon found to be an imperfect solution to the problem of detach-

ment as they sometimes caused cracking in the earthen plaster when inserted and they created stress in the painting around the anchor.

In the mid-1980s, in preparation for the opening of the cave to visitors, movable glass screens were installed in the cave to prevent touching of the wall paintings, the concrete floor of the cave was covered with concrete tiles, and the wooden entrance door was replaced with an aluminium alloy louver door.

In 1998 a severe episode of exfoliation—flaking of the paint, ground, and fine plaster layers—occurred in cave 85. This was associated with high ambient humidity after extended rainfall. Emergency treatment, which involved microgrouting with a clay slurry, was undertaken by the DA-GCI team to readhere and re-lay areas of exfoliation.

Summary of Interventions

The history of interventions in cave 85 indicates that since the 1950s the wall paintings have undergone three major periods of treatment: 1950s, 1970s, and 1998. These interventions have included plaster fills of areas of loss, reattachment of painted plaster that had separated from the rock walls, flake fixing of the paint layer, and, most recently, treatment of exfoliation. The repeated cycles of treatment—approximately every twenty-five years—and the corresponding continued loss of the painting indicate ongoing deterioration in cave 85 and failure to mitigate the mechanisms of deterioration.

This is clearly demonstrated by looking at condition records that show, in 1974, a grayish plaster repair used to fill



FIGURE 5 Example of the steel anchors used to secure areas of detached painted plaster in cave 85. The anchor was painted to match the decoration of the original painting.



FIGURE 6 Example of the visual glossary for “exfoliation.”

Photographic Survey of the Wall Paintings

Photographic documentation of the painted surface of the cave was carried out in both color and black-and-white. The photographs serve as an archival record of the condition of the cave prior to conservation intervention. The black-and-white prints, 20 by 28 centimeters, were used as base maps to graphically record condition. The images were also used during the project as baseline documentation for monitoring change and to help identify any new losses in the paintings.

Due to the sheer size of the cave, photography was broken down into 532 sections measuring 85 by 110 centimeters (photographed with 5–10 cm overlap on each side). The semirectified

an area of new loss of painting on the west ceiling slope. This loss must have occurred sometime after the 1950s, when all areas of loss were filled with plaster repairs. Likewise, since 1974 two more losses have occurred on the west slope, the most recent in 1996.

Following treatment for flaking in 1974, wall paintings in the antechamber, the corridor, and the front part of the main chamber appear to have remained stable. In contrast, toward the west end of the main chamber, in an area previously treated, exfoliation—a more serious form of paint flaking—developed, and ongoing losses have been recorded.

Survey of Current Condition

In 1998, as part of the DA-GCI collaboration, work began on a comprehensive survey of the existing condition of the wall paintings in cave 85. The survey included photography, graphic documentation, and detailed documentation of the types of deterioration and their distribution.

photographs were taken by positioning the 35 mm camera at a fixed distance (140 cm) from the wall, keeping the film plane parallel to the wall surface. Each photograph includes the date, wall name, and wall section number (using an established section identification system) and gray and color scales. Illumination was provided by two 1,000 W quartz halogen lamps. Light meter readings were taken periodically for consistent illumination. Kodak T-max 100ASA and Kodachrome 64ASA film were used.

Classification of Deterioration Types

During preliminary examination of the wall paintings, team members created a bilingual list of deterioration phenomena to be recorded. This glossary focuses on aspects of condition, original technique, and evidence of previous intervention. The glossary includes both a written description and a photograph of each phenomenon (fig. 6). This visual glossary is an important and useful tool to ensure standardization of the graphic recording process and to facilitate subsequent interpretation.



FIGURE 7 The graphic documentation key.

Graphic Condition Recording

Using the predetermined deterioration categories and legend (fig. 7), deterioration was mapped on transparent paper overlaid on the black-and-white photographic prints at 1:5 scale (fig. 8). Altogether, 523 sections were recorded by hand and are archived at the Dunhuang Academy. Manual graphic documentation was subsequently computerized, using AutoCAD software, to summarize the information on measured line drawings by entire wall and slope (1:20 scale) in order to illustrate general patterns of deterioration within the cave and to provide greater flexibility in the analysis and presentation of data. In addition, a three-dimensional model of the cave was constructed and condition overlaid to show the spatial distribution of deterioration in cave 85 (fig. 9).

Results of the Condition Survey

The main types of deterioration phenomena in cave 85 include the following:

- In-depth deterioration (i.e., of plaster layers) covering collapse with loss of plaster and loss of adhesion



FIGURE 8 Example of the manual graphic documentation carried out using overlays on photographs.

(detachment) between the plaster and the conglomerate rock; and

- Surface or subsurface deterioration (i.e., of paint, ground, and upper plaster layers), which includes blistering and flaking of the paint and/or ground layers, combined lifting of the paint, ground, and upper plaster layers (exfoliation; fig. 10), and surface salt-related deterioration such as disruption, punctate losses, and crater eruptions.

Among these conditions, plaster detachment from the rock and a combination of surface conditions, which include primarily flaking and exfoliation and powdering of the paint layer, were the most serious, resulting in ongoing and visible loss of the painting.

Both in-depth and surface conditions showed a similar distribution pattern throughout the cave on a southeast to northwest axis (on both walls and ceiling slopes), increasing in severity toward the northwest end of the cave and most severe at the upper northwest corner of the cave. In contrast, the east end had noticeably less plaster detachment (with the exception of a large area on the north side of the east wall)



FIGURE 9 Scale model (1:35) of cave 85 with condition overlaid to show the distribution of deterioration.

or surface deterioration; since being treated in the 1970s, this area has remained stable.

In summary, it is clear that all forms of ongoing deterioration progressively worsen in both severity and extent toward the west end of the cave, with a concentration in the northwest corner. Visible surface salt activity also increased toward the west end of the cave.

Conclusion

An understanding of both current and past conditions of the wall paintings in cave 85 and knowledge of past interventions has helped to identify and demonstrate those conditions that are considered most serious and are causing ongoing deterioration. This information, together with the diagnostic investigation, which includes both environmental study and analytical investigation, has been fundamental to understanding the processes and the causes of deterioration affecting the cave today.

Acknowledgments

This paper represents the participation of many more team members, from both the Dunhuang Academy and the Getty Conservation Institute, than the eight authors listed above. In particular, much of the behind-the-scenes work was undertaken by the documentation group of the Dunhuang Academy and the Digital Lab of the Getty Conservation Institute. In addition, the conservation team for the cave 85



FIGURE 10 Area of severe exfoliation of the wall paintings in the northwest corner of cave 85.

project, led by Fan Zaixuan, with conservators Stephen Rickerby and Lisa Shekede, provided expertise in the overall recording process and were helpful in the recording of difficult conditions such as plaster detachment.

Notes

- 1 Zhang Daqian (1899–1983) was an artist who visited the Mogao Grottoes between 1941 and 1943.
- 2 Paul Pelliot (1878–1945) was a French explorer and sinologist who visited the Mogao Grottoes in 1908.
- 3 The construction chart number is Dunhuang Shi Sui 017.

References

- Duan Xiuye and Sun Hongcai. 1990. A report on the restoration of the alkalized murals in cave 85 at the Mogao Grottoes. *Dunhuang Research* 3: 92–94.
- Pan Yushan, Ma Shichang, and Dunhuang wen wu yan jiu suo. 1985. *Mogao ku ku qian dian tang yi zhi = Foundations of the Original Cave Temple Facades at Mogao*. Beijing: Wen wu chu ban she: Xin hua shu dian Beijing fa xing suo fa xing.
- Shi Zhangru. 1996. *Mogao ku xing*. Zhong yang yan jiu yuan li shi yu yan yan jiu suo tian ye gong zuo bao gao, no. 3. Taipei: Zhong yang yan jiu yuan li shi yu yan yan jiu suo.

Causes and Mechanisms of Deterioration and Damage in Cave 85

Neville Agnew, Shin Maekawa, and Shuya Wei

Abstract: Wall paintings in cave 85 at the Mogao Grottoes of Dunhuang show detachment (or separation) of the painted earthen plaster from the underlying rock, making it vulnerable to collapse and various forms of deterioration of the paint layer and substrate. Deterioration correlates with the amount of hygroscopic salts (mainly sodium chloride) in and under the plaster on the west wall backed by the conglomerate rock body of the cliff. The relative humidity for the onset of absorption by the salts is 67 percent, a value frequently exceeded in the cave. Salt enrichment at the cave wall is considered to occur by diffusion of water vapor from the porous rock body. The cave is dry, without evidence of liquid water infiltration from above or through the walls; neither does condensation on the walls occur. Humidity in test holes in a comparable cave exceeds the deliquescence value of salts at a depth of 50 centimeters. The source of water vapor is not definitively known but is likely the deep water table or some distant source. Salt migration to the plaster layer occurs by the phenomena of capillarity and salt “creep” at the evaporative front. The driving force is the humidity differential between the rock body and the cave atmosphere. Historically, during periods of sustained high ambient humidity, as from flooding of the floor of the cave, the rock and atmospheric humidity are believed to have equilibrated, resulting in progressive salt enrichment during subsequent drying phases. Over the 1,100 years since the excavation of the cave cycles of deliquescence and crystallization from intrusion of atmospheric water vapor acting in tandem with humidity in the rock have resulted in the present deterioration. Geologic inhomogeneities and fissures and the cracked and deteriorated plaster likely contribute to the diffusion of water vapor and salt migration. Laboratory experiments have shown the facility with which salt migrates through the rock.

For the future, a stable climate in the cave below 67 percent relative humidity is necessary for its best preservation. This means preventing intrusion of air via the doors during rain or periods of high external humidity, which, in turn, requires closing the cave to visitors when these conditions occur.

This paper considers natural, rather than human-induced, causes of deterioration and damage observed in cave 85. Though the focus is on this cave, the deterioration phenomena generally pertain to other cave temples of the Mogao Grottoes as well. Other papers on cave 85 in the present volume classify and describe the deterioration observed in detail (detachment, flaking and peeling of paint, powdering of the fine plaster, etc.).

Deterioration phenomena at Mogao vary from cave to cave and with vertical distribution on the cliff face: the most severely deteriorated caves are typically at ground level, followed by the uppermost caves, with the best preservation at mid-tier. Cave 85 is located at ground level and has suffered extensive deterioration, particularly on the west wall and the western sides of the north and south walls. In the past, flooding of the floor caused complete loss of wall paintings and earthen plaster to a height of about one meter and enriched the soluble salts content in the exposed conglomerate. This loss and the manifestly poor condition of the entire west wall (backed by the rock of the cliff) are also the most apparent kinds of deterioration in many, but not all, caves at ground level.

At Mogao a latent catastrophic threat is detachment of painted plaster; extensive areas have separated from the conglomerate, and over time many segments have fallen under their own weight, particularly after prolonged peri-

ods of high ambient humidity, most recently in 1996 after several days of rain. The Dunhuang region is rated seismicity degree 6 on the national classification scale (Sun Rujian 1997), and the next temblor will result inevitably in collapse of many detached areas of painting. An earthquake of magnitude 6.5 to 7 on the Richter scale has been predicted for the region (Fan Jinshi 1997).

Deterioration of the earth-based wall paintings is caused by humidity and salts from the rock in and on the painted plaster. Detachment or separation of the plaster from the conglomerate is probably inherent, to some extent, from the time of construction of the cave but is exacerbated by cycles of deliquescence and crystallization of salts at the interface between the rock and the plaster. The present paper endeavors to identify the mechanism of enrichment of salts and areas for further investigation. Other contributions to this volume also address the sources of moisture, and in a sense the present paper attempts to mediate between the views presented by Maekawa and colleagues on the one hand and Tanimoto and colleagues on the other: the former have monitored atmospheric moisture vapor in the cave and in test holes in the rock, whereas the latter emphasize regional geology and local hydrology and the movement of both liquid water and water vapor in the rock as being key.

Salts, Water, and Deterioration

Moisture in caves and tombs in the presence of soluble salts causes great harm. In desert climates, however, in the absence of direct evidence of water seepage, the mechanism whereby salt enrichment occurs at and near the wall surface seems not to be definitively understood. For example, G. Torraca (1984) speculated that salt damage in the tomb of Nefertari in the Theban necropolis was attributable to the growth of crystals due to evaporation after occasional wetting, activated by air circulation in the tomb. Yet the tomb entrance was closed perhaps for three thousand years after the tomb had been looted, and although there is rare flooding in the Valley of the Queens, there is no evidence of liquid water intrusion into the deepest chamber, where salt buildup between the painted plaster and the limestone bedrock was observed to be up to 25 millimeters thick in places. Instead, moisture seeping into the porous rock via joint planes and fissures and diffusing to the tomb as vapor seems probable. How thoroughly the Nefertari tomb was sealed against air exchange with the outside is not known and was apparently not remarked on by Schiaparelli at the time of its discovery

(1904). Air exchange would create a driving mechanism for salt enrichment on the chamber walls.

Tutankhamen's tomb, on the other hand, was hermetically sealed and was reported by Carter to have a close and humid atmosphere when first opened in 1922 (Carter and Mace 1963). The organic artifacts present were in equilibrium both with the internal atmosphere and with the humidity of the surrounding rock, as evidenced by the changes that began immediately on their exposure to the dry external atmosphere. Carter surmised that water had filtered through the permeable limestone from an external source, but he was unable to see locations where water had entered, nor was there evidence of infiltration damage on the wall paintings or buildup of salt as in Nefertari's tomb. Plausibly, the external source provided only water vapor, which periodically diffused through the limestone to equilibrate with the cavity of the tomb and its contents.

At Mogao, in general, with the exception of ground-level flooding and rainwater infiltration in upper-tier caves where erosional thinning and sometimes collapse of the rock of the roof occurred, liquid water is not a factor in deterioration. An observation, however, among many caves that lost their wooden temple facades, it is believed, in the centuries of abandonment after the Ming period, is that windblown sand filled the entranceways, and this caused water to be wicked into the cave during wet periods. Typically, these caves show loss of painted plaster where the wet sand had banked against the walls, quite often extending through the corridor as far as the main chamber.

Hygroscopic salts in porous materials (stone, ceramics, earth- and clay-based artifacts) cause deterioration through cycles of deliquescence and recrystallization. Values of RH_{eq} (the equilibrium relative humidity generated in a closed vessel by a saturated aqueous solution of a pure salt at a given temperature) are well known (e.g., for NaCl, it is 75%), but in mixtures and in those salts that form crystalline hydrates the situation is complex (Price 2000). The exact mechanism of deterioration by salts is still not settled, but it seems generally true that damage occurs when they crystallize. The assumption that environmental humidity less than the RH_{eq} of a soluble salt will not result in damage is in doubt. Studies (Nunberg and Charola 2001) have noted deterioration from changes in relative humidity between 43 and 55 percent using sodium chloride and sodium sulfate and mixtures of both in porous materials. Presumably interstitial capillary condensation is the phenomenon whereby some of the salts present are brought into solution well below their RH_{eq} . Weight

changes in the test materials of less than 0.5 percent, in the case of NaCl, were observed and damage was small, but the finding may be significant to damage over long periods and should be corroborated by further work and for relevance to sites such as Mogao.

Conservation Issues

Since it is impossible, in fact inadvisable, to attempt to extract even a significant fraction of the soluble salts from the Mogao wall paintings (see, eg., Cather 2003), environmental control of caves at risk must be the damage mitigation method of choice in the long term. Conservation treatments, including partial salt reduction as in poulticing, require understanding of the cause-and-effect relationship between humidity and hygroscopic salts both at a general level and, preferably, in detail, including rates of moisture-mediated deterioration in salt-enriched substrate. For example, attempts at desalination of painted brick vaults in a church in Denmark by RH control have been made. These were not effective for a variety of reasons (Larsen 1999). Rates of deterioration will depend on the rate of adsorption of water vapor by salts, which in turn depends on crystal size, air movement, and porosity of the plaster and rock. Thus collapse of detached plaster in cave 85 occurred after some five days of rain when sufficient moisture had been adsorbed to affect the strength of the plaster through dissolution of salts and increased plasticity of clay. The plaster itself (36% sand, 45% silt, 19% clay) was derived from Daquan River sediment and contains, in the clay fraction, 30 percent swellable clays (illite/smectite) (Austin 1998). Laboratory experiments show detectable mass increase in salt-laden conglomerate after about three hours at 85 percent relative humidity.

Key Questions

To understand the situation at the Mogao Grottoes site, a number of questions were posed:

- In the desert climate of Dunhuang what is the source of moisture in cave 85—is it entirely atmospheric, or does hydrologic (i.e., geologic) water also play a role?
- What is the critical relative humidity at the walls in cave 85 for deliquescence of salts (mainly NaCl), and how long does it take to absorb moisture? Does capillary or interstitial condensation play a role?
- How did salt enrichment at the conglomerate-plaster interface, and in the plaster layer, occur over time; that is, what is the origin and what is the mechanism of enrichment?
- Why are some caves more deteriorated (due to more salts in the plaster) than others?
- Has atmospheric condensation occurred on the wall paintings?

From the salt distribution in the plaster of the west and east walls of cave 85 (Wong et al., this volume) it is apparent that there is more salt in the west wall (av. 3.4 wt%), which shows severe deterioration, than in the east wall (av. 1.2 wt%), which is much less damaged. Cave 98 is another large ground-level grotto with a distribution of deterioration and salt content (av. 3.9 wt%) similar to that of cave 85. By contrast, exterior, exposed conglomerate contains 0.15–0.77 wt% (av. 0.3) salts along a vertical profile of the cliff. The inference is that enrichment of salt occurred by extraction from the rock body. The west wall, excavated into the bulk of the mother rock, would have a far larger reservoir of salt and water vapor than the east wall, which forms the outer face of the cave. One would expect, therefore, that as a general rule the west walls of caves would show greater deterioration than the east walls. This is generally true. Cave 61, however, with less salt (av. 1.5 wt%) than cave 85, is not so seriously deteriorated on its west wall as are caves 85 and 98, though it is quite close to cave 85 and is topographically lower in elevation as well. Furthermore, caves 85, 98, and 61 were all historically flooded. A hypothesis about salt enrichment must endeavor to explain this. This point is returned to later.

For salt enrichment to occur at the surface of the wall, moisture is needed. As mentioned, there is no evidence that this was liquid water; instead, water vapor is implicated. At the scale of the site, consistent baseline concentration of salts in the rock of the cliff face (both vertically and horizontally) is unlikely, however, particularly where geologic inhomogeneities, both petrological (e.g., lenses of sandstone in the conglomerate) and structural (cracks), occur, as discussed below.

Sources of Moisture

There are a number of possible sources of moisture to have mobilized salts and that contribute to deterioration:

- Cave construction: Water from the wet earthen plaster and prewetting of the walls prior to plaster-

ing. There is no historical information on this. It would seem improbable that a single event, such as wet mud plaster, could lead to 4 wt%, or more in some locations, of salts being extracted from the relatively low (average 0.3 wt%) natural concentration in the exterior conglomerate.

- Geologic: Water vapor content in the porous rock that increases to saturation at 1 meter (figs. 1, 2), as shown in two monitoring holes in the west wall and one in the floor of cave 98 (wall holes were 1.5 meters above the floor, 0.5 meter from the north and south walls, and 1.3 meters deep; the floor hole was 1.5 meters from the west and east walls and 1.3 meters deep). Even though the water table is at least 20 meters deep, according to the Dunhuang Academy, humidity in the floor hole was similar to that observed in the walls. The moisture content at all areas of the conglomerate along the cliff face is unlikely to be the same because of fractures in the rock, intersections with fault planes, lenses of sandstone with different water vapor permeability, and areas of greater porosity, where the conglomerate is inhomogeneous, allowing more rapid diffusion of water vapor.

- Meteorologic: Intrusion of external humidity via the entrance to the cave.
- Flooding and irrigation: Past flooding of the Daquan River, manifested as loss of painted plaster above the floor level, is evident in many ground-tier caves, often to a height of about 1 meter. As mentioned previously, some cave entrances at ground level were also filled with windblown sand, and this too resulted in loss of painted plaster when sand heaped in the entrance and the corridor was wetted. Irrigation of the trees growing in front of the grotto zone has frequently been cited as a cause of moisture intrusion by means of lateral migration into the caves, but this has been refuted by the work of Maekawa et al. (this volume). Tanimoto et al. (this volume) disagree based on resistivity measurements outside the caves.
- Condensation: Environmental data of many years show that the dew-point temperature in the caves is not reached in the summer, and thus wall condensation can be discounted (Maekawa et al., this volume).

Humidity caused by visitors to the caves is unlikely to contribute to salt enrichment, though visitors' effect on

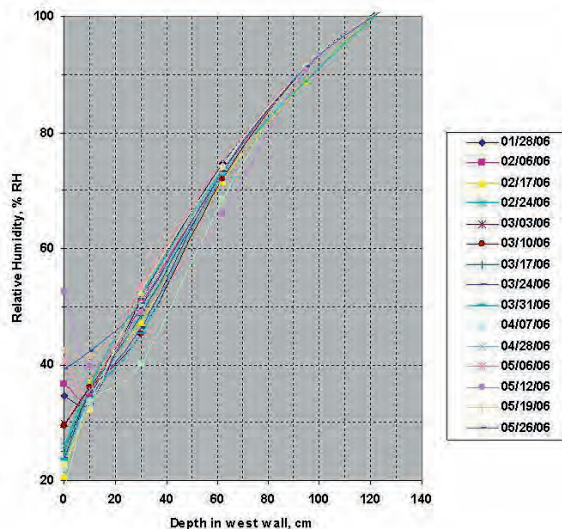

FIGURE 1 Relative humidity in the conglomerate of the west wall of cave 98 as a function of depth and season. Fluctuations due to the cave environment extend to a depth of 10 centimeters. Individual sensors in the monitoring hole were well isolated from each other.

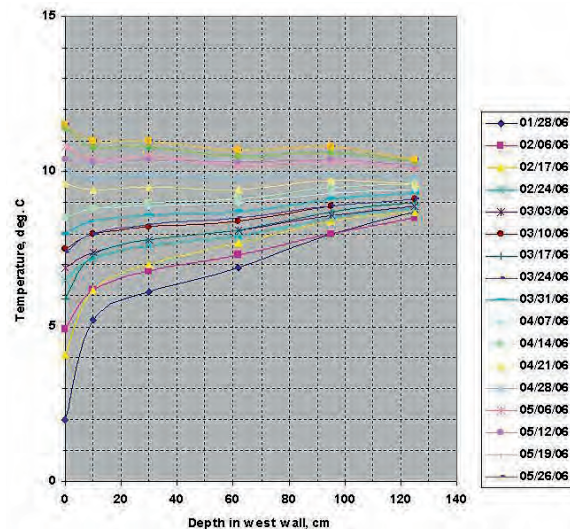

FIGURE 2 Temperature in the same monitoring hole shown in figure 1. Seasonal temperature variations extend more than 100 centimeters into the rock.

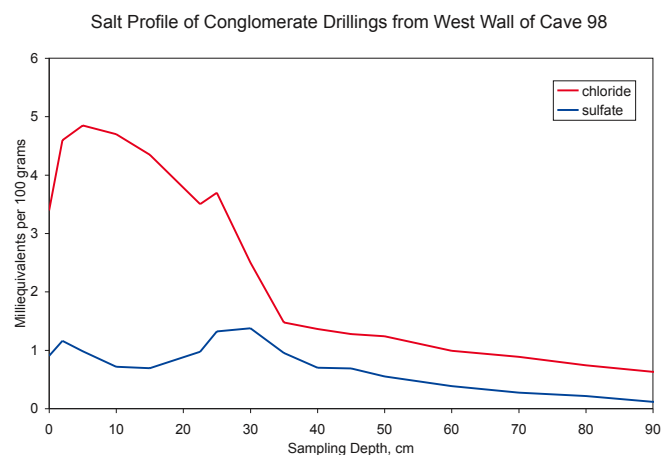

FIGURE 3 Chloride and sulfate ion distribution with depth in the same monitoring hole shown in figures 1 and 2. (Data provided by Dunhuang Academy)

humidity (about 5% increase over ambient) is real. However, the visitor carrying capacity study for the grottoes has shown that this effect can be neglected (Demas et al., this volume).

Interpretation

Salt migration and accumulation at and near the surface can only occur as a result of dissolution of the salt. Differences between caves in amount of salts and in degree of deterioration need be accounted for. Historical flooding of the floor alone cannot explain the lower salts content in cave 61 or the lesser salt damage observed. Maekawa's data show that the cave 85 walls are also "conditioned" in summer by intrusion of high external humidity, presumably because of moisture uptake by salts and plaster. This points to external humidity as being the cause of the marked difference in the condition of the wall paintings observed in caves 85 and 61.

It is proposed that the above observations can be explained both by geologic moisture vapor diffusion through the rock and by intrusion of humid meteorologic air via the cave entrance. The actual process of salt enrichment suggested is transport of salts in solution through capillary condensation and migration of solution close to the rock surface, where a zone of enrichment occurs due to crystallization. Figure 3 shows this accumulation in the conglomerate in cave 98. Salt creep is an everyday observation (fig. 4). It is essentially this process that is being proposed for salt accumulation at the cave wall via the intrusion of meteo-

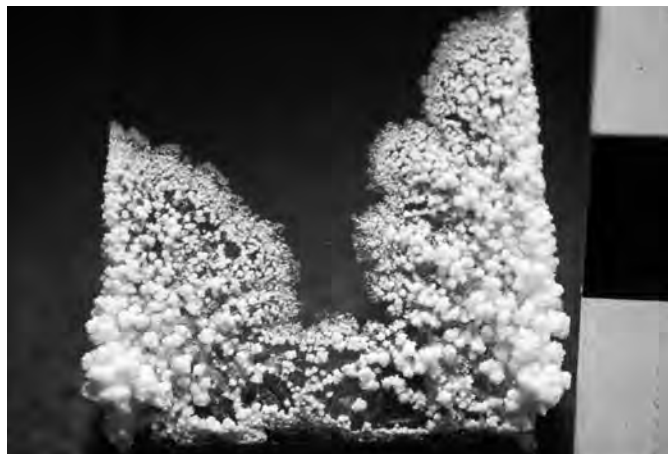

FIGURE 4 Creep of sodium chloride up a microscope slide as the solution evaporated.

rologic moisture and its adsorption by the plaster and rock during periods of high and sustained humidity. Pühringer (1983, 2002a) has proposed a possible mechanism for water vapor-induced migration of soluble salts in porous substrates during atmospheric humidity cycling. This is based on his explanation of the phenomenon of salt creep (Ginell 2005). Over the millennium and more since the caves were created, these two processes have abetted each other, leading to the accumulation of salt. It is shown in laboratory studies, discussed below, that salt migration to the evaporative surface can occur by a humidity differential. Once enrichment has occurred at the plaster-to-rock interface meteorologic

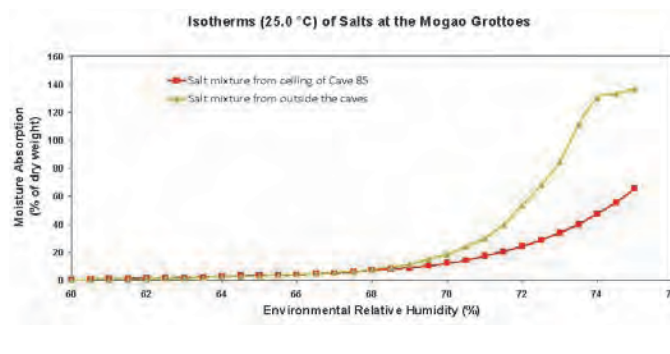

FIGURE 5 Weight increase as a function of relative humidity of salt mixtures sampled from the interface between the plaster and conglomerate in cave 85 and taken from external conglomerate.



FIGURE 6 Sodium chloride migration experiments. (a) Conglomerate; (b) conglomerate with a layer of clay plaster, half of upper surface painted with pigments found at Mogao.

humidity dominates as the active mechanism of deterioration. This begins to occur with each high relative humidity event that is sustained for more than an estimated four to six hours above the value of 67 percent relative humidity (fig. 5).

The difference between caves 85 and 61 is best accounted for in terms of geologic inhomogeneities in the west walls, the former having more fractured rock and stratigraphic differences such as highly porous sandstone lenses intercalated with the conglomerate. It does not seem possible to resolve the question of the geologic role behind the plaster surface without further investigation.

Laboratory Studies

Salt (NaCl) migration experiments were undertaken on both the conglomerate and the sandstone from lenses that occur throughout the former. Experiments used a humidity differential across test samples. Briefly, small samples (about 25 millimeters thick, roughly square) were embedded around four sides in wax and sealed into a glass container (fig. 6). The samples had salt applied to the undersurface and were then alternately equilibrated in a chamber at two relative humidities (first at 85% and then at 43% on the two opposed faces) until salt appeared on the upper surface (fig. 7).

Results were as follows. Salt migrates through conglomerate with facility, appearing on the upper surface after five complete cycles. Sandstone samples, while equilibrated

ing much more rapidly than the conglomerate, show a salt distribution throughout the body of the sample but without the appearance of salt on the upper surface. The difference in salt profile between conglomerate and sandstone suggests that pore characteristics play a role in transporting salt. The greater abundance of fine material in the conglomerate may enhance capillary transport, while the larger pores in the sandstone allow rapid penetration of humid air and

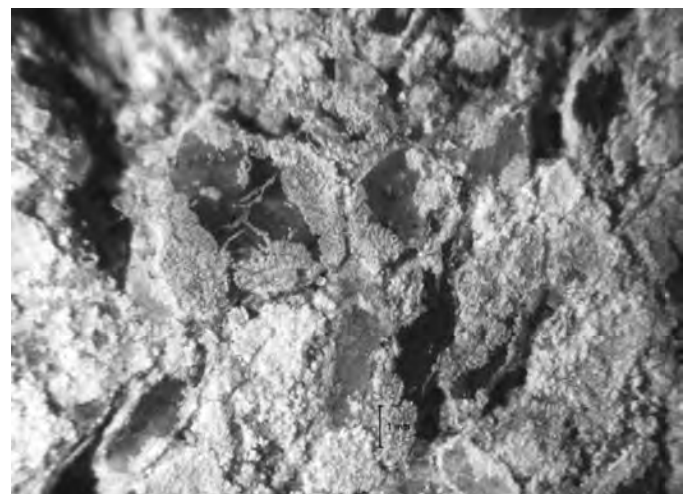

FIGURE 7 Sodium chloride crystallization on upper surface of conglomerate. Note salt creep around edges of larger grains.



FIGURE 8 Salt eruption on the unpainted clay plaster.

distribution of salt. Total porosity and pore size distribution are yet to be determined for conglomerate and sandstone, however. It would be informative to know whether sandstone lenses occur on the west wall of cave 85; however, the plaster on this wall is intact (with the exception of the base, where it has been lost) and a noninvasive technique of sufficient sensitivity is not available. Sandstone would transport less salt to the surface but is more permeable to water vapor migration into the bulk of the rock, thereby mobilizing more salt from the subsurface zone of enrichment.

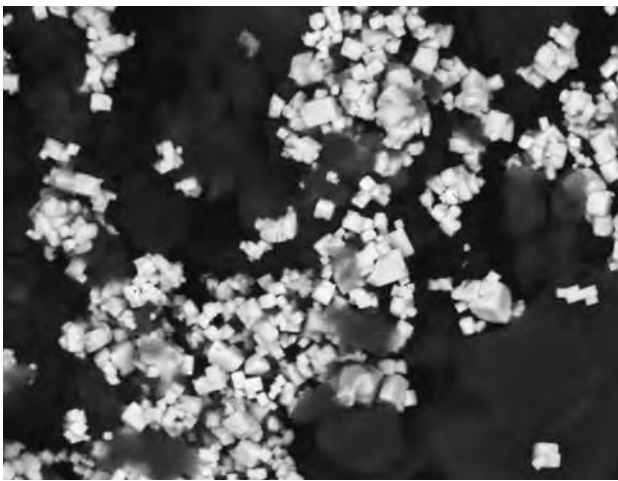

FIGURE 9 Well-formed cubic crystals of sodium chloride below the paint layer (also at the clay-conglomerate interface).

A further relevant observation was that in samples of conglomerate that were overlaid with clay plaster and painted with pigment and binding medium, replicating those in the caves, sodium chloride eruption occurred on the clay surface (fig. 8) but was not observed on the paint surface. Instead, on examination of lifted paint flakes, euhedral crystals of salt were observed (fig. 9). Only in one instance, after five cycles, did the beginning of damage to the paint layer occur. Moreover, accumulation of salt at the conglomerate-clay interface was observed. In the caves this is a probable contributor to plaster detachment because of disaggregation and fretting of the rock from cycles of deliquescence-recrystallization. In other words, conglomerate may recede behind the plaster by salt-induced fretting; it is not buildup of salts that detaches plaster.

Discussion

Note that distinction is made between historic and recent deterioration. Most likely serious damage occurred, or the conditions were established for subsequent deterioration, during the several centuries of abandonment. Moisture intrusion from flooding and sand would have resulted in prolonged periods of high humidity. As atmospheric drying took place salts moved by creep from within the rock to the plaster, resulting in separation from the conglomerate, disruption of the plaster, and other forms of salt-induced deterioration.

Laboratory experiments show that it is possible to cause salt to migrate through porous media (conglomerate, sandstone, earth-based plaster) with cycles of humidity differential above and below RH_{eq} of the salt. To what extent is this an accurate simulation of the situation in cave 85 and other caves? To what extent does atmospheric humidity above the value of 67 percent relative humidity penetrate through painted earthen plaster that is clay rich and diffuse into the conglomerate? The conglomerate sample with clay plaster on top took about twenty days in the laboratory to equilibrate across the sample when the differential was 85 and 43 percent relative humidity. This was a static air experiment in a closed chamber. In the case of the caves, the penetration of humid air should be faster because of air movement, cracks in the painted surface, and the already salt-deteriorated plaster. Just how fast and how deep the “front” of humid air would penetrate through and into the mother rock is not known exactly, though the test holes in cave 98 showed seasonal RH/T variations to a depth of

10 to 15 centimeters. To bring to or near the surface the quantities of salts seen in the west wall of cave 85 presumably the penetration would have to be sufficiently deep to reach the zone of salt enrichment (in cave 98 where the clay plaster has been lost on the west wall, the maximum in chloride content is about 5 to 10 centimeters from the surface, with sulfate at 25 to 30 centimeters) and require extended periods of high humidity in the cave, as well as cycles of high and low humidity. Given, however, the circumstances of the age of the cave (1,100-plus years), evidence of past flooding, and occasional periods of extended rainfall, the conditions and time required for salt migration and enrichment at and near the surface are likely to have been met.

Conclusion

This paper has been concerned not with the mechanisms of salt-induced deterioration of wall paintings in cave 85 but rather with understanding the conditions and processes by which the low concentrations of natural salts in the conglomerate moved to and became concentrated close to the wall paintings, mainly at the rock-plaster interface, by the interplay between water vapor from the rock body and meteorologic humidity.

The findings are pertinent both to how the salt has migrated and accumulated on the west walls and at what interfaces it accumulates, that is, conglomerate to clay plaster; clay plaster to paint layer. But questions still remain, and the discussion above has been simplified by considering essentially only sodium chloride in the laboratory experiments, whereas analysis of the salt species present in Mogao conglomerate indicates a range of other ionic types (mainly sulfate), which contribute to a lowering of the deliquescence RH but may also contribute to accelerated deterioration.

The purpose of this paper has been to understand qualitatively the complex interactions between water vapor (from both the atmosphere and the rock body), hygroscopic salts in the conglomerate and plaster, and the thin surface of paint that led to the deterioration seen today. Discussion of the cause and effect of the phenomena is clearly provisional, and research at a fundamental physicochemical level is needed. For effective preservation of the wall paintings at the Mogao Grottoes and the many other similar sites in China and along the Silk Road, a combination of environmental controls and treatment and salt reduction techniques must depend on a complete understanding and diagnosis of all the deterioration mechanisms, their causes and rates.

Further Work

The physics of water and salt transport in porous media is exceedingly complex, as indeed is the mechanism of deterioration of stone by salts. Many studies have been undertaken and the literature is extensive (Ginell 2005). In addition to the work of Pühringer (2002b), there are useful papers in the volume edited by A. E. Charola (2005). In the past decade or so new tools have been applied to the problem, particularly nuclear magnetic resonance (see, e.g., Petkovic 2005). Other work of relevance, though technical, has been published by F. A. L. Dullien (1979). D. Camuffo (1995) provides a concise overview of stone weathering; more accessible to the conservator is the paper by Bionda (2004).

Most published work in the conservation literature has been concerned with mechanisms of deterioration of stone by salts and to a much lesser degree with the salt enrichment process at the surface and subsurface. A generalized, nontechnical explanation of conditions under which salt enrichment occurs for particular rock types, salt mixtures, environmental conditions, and so forth is necessary to aid conservation practitioners in diagnosis and development of remedial and preventive measures.

In the particular case of the Mogao Grottoes further field investigations on salt profiles, water vapor sources, and subsurface zones of enrichment are needed to corroborate or refute the suggested mechanisms proposed here and in the debate regarding the origins of moisture.

Acknowledgments

The authors are grateful to colleagues at the Getty Conservation Institute, Lorinda Wong, Francesca Piqué, and Michael Schilling, who participated in the cave 85 project. Their commitment to the project, helpful discussion and comments, and analytical and environmental results used in this paper are much appreciated. William Ginell extensively reviewed the literature on moisture and salt transport in porous media, and Eric Doehne provided scanning electron microscope images and comment on the characteristics of the rock types used in the laboratory experiments. Staff of the Conservation Institute of the Dunhuang Academy, Chen Gangquan, Su Bomin, and Fan Yuquan, generously provided chemical data for the conglomerate salts from the cliff face and test holes in cave 98 and shared their detailed knowledge of the site. Wang Xudong kindly approved the request to drill two holes in the west wall and one in the floor

of cave 98 in order to monitor humidity and temperature and determine salts content by analysis of the cuttings.

References

- Austin, G. S. 1998. Analysis of Mogao Grottoes earthen materials. Unpublished report to the Getty Conservation Institute from New Mexico Bureau of Mines and Mineral Resources.
- Bionda, D. 2004. Salt deterioration and microclimate in historical buildings: Intermediary report of the project "Sustained care of sensitive historical monuments." Institut für Denkmalpflege, Forschungsstelle Technologie und Konservierung, ETH Zürich. <http://e-collection.ethbib.ethz.ch/view/eth:27193>.
- Camuffo, D. 1995. Physical weathering of stones. In *The Deterioration of Monuments*, ed. C. Saiz-Jimenez, 1–14. Science of the Environment, vol. 167. Amsterdam: Elsevier.
- Carter, H., and A. C. Mace. 1963. *The Tomb of Tut•Ankh•Amen, Discovered by the Late Earl of Carnarvon and Howard Carter*. Vol. 1. New York: Cooper Square Publishers.
- Cather, S. 2003. Aqueous extraction of soluble salts from porous materials: Alternatives and contra-indications. In *Mauersalze und Architekturoberflächen*, ed. H. Leitner, S. Laue, and H. Siedel, 167–72. Dresden: Hochschule für Bildende Künste.
- Charola, A. E., ed. 2005. *Selected Papers on Salt Damage and Desalination*. Special issue. *Internationale Zeitschrift für Bauinstandsetzen = International Journal for Restoration of Buildings and Monuments* 11 (6).
- Dullien, F. A. L. 1979. *Porous Media, Fluid Transport and Pore Structure*. New York: Academic Press.
- Fan Jinshi. 1997. Fifty years of protection of the Dunhuang Grottoes. In *Conservation of Ancient Sites on the Silk Road: Proceedings of an International Conference on the Conservation of Grotto Sites*, ed. N. Agnew, 12–22. Los Angeles: Getty Conservation Institute.
- Ginell, W. S. 2005. Salt migration in the Mogao caves. Unpublished report for the Getty Conservation Institute.
- Larsen, P. K. 1999. Desalination of painted brick vaults. Ph.D. diss., Department of Structural Engineering and Materials, Technical University of Denmark, Series R, no. 52.
- Nunberg, S., and A. E. Charola. 2001. Salts in ceramic bodies II: Deterioration due to minimal changes in relative humidity. *Internationale Zeitschrift für Bauinstandsetzen = International Journal for Restoration of Buildings and Monuments* 7 (2): 131–46.
- Petković, J. 2005. Moisture and ion transport in layered porous building materials: A nuclear magnetic resonance study. Ph.D. diss., Eindhoven University of Technology.
- Price, C. 2000. Salt damage in porous materials. In *An Expert Chemical Model for Determining the Environmental Conditions Needed to Prevent Salt Damage in Porous Materials*, ed. C. Price, 3–12. Research report. European Commission, Directorate-General XII, Science, Research, and Development, no. 11. London: Archetype Publications.
- Pühringer, J. 1983. *Salt Disintegration: Salt Migration and Degradation by Salt: A Hypothesis*. Swedish Council for Building Research, no. D15. Stockholm: Statens rad for byggnadsforskning.
- . 2002a. Deterioration of materials by salt precipitation: Technical aspects of "crystallization/hydration." *Internationale Zeitschrift für Bauinstandsetzen = International Journal for Restoration of Buildings and Monuments* 8 (5): 512–36.
- . 2002b. Hygrothermic deterioration of materials by salts: A technical approach. *Internationale Zeitschrift für Bauinstandsetzen = International Journal for Restoration of Buildings and Monuments* 8 (4): 349–70.
- Sun Rujian. 1997. Review of stabilization projects at the Mogao Grottoes. In *Conservation of Ancient Sites on the Silk Road: Proceedings of an International Conference on the Conservation of Grotto Sites*, ed. N. Agnew, 159–69. Los Angeles: Getty Conservation Institute.
- Torraca, G. 1984. *International Symposium on the Conservation and Restoration of Cultural Property—Conservation and Restoration of Mural Paintings*. Tokyo: Tokyo National Research Institute of Cultural Properties.

Methodology for the Conservation of the Wall Paintings in Cave 85

Francesca Piqué, Lorinda Wong, and Su Bomin

Abstract: *The extent and severity of the deterioration of the wall paintings in cave 85 at the Mogao Grottoes exemplified the need for a methodological approach to their conservation, one that is based on an understanding of the materials, technology, and causes of deterioration and that favors minimal intervention and preventive conservation. In the past, wall painting conservation at Mogao consisted of repair treatment carried out without addressing the causes of deterioration. To address causes of deterioration it is necessary to follow a methodology of investigation, assessment, and diagnosis prior to the development and implementation of preventive measures and stabilization treatments. The collaborative project between the Getty Conservation Institute and the Dunhuang Academy for the conservation of the wall paintings in cave 85 has been developed as a model case study of the methodology advocated in the Principles for the Conservation of Heritage Sites in China. This paper illustrates the application of the conservation methodology through the different phases of the program.*

The Getty Conservation Institute (GCI) has been collaborating with the Dunhuang Academy (DA) since 1989 to address sitewide conservation problems such as sand migration and erosion. Since 1997, in the second phase of this collaboration, the focus has been on conserving the wall paintings and sculpture of cave 85, using the methodology of the *Principles for the Conservation of Heritage Sites in China* (the China Principles), national guidelines developed in a three-way partnership between China's State Administration of Cultural Heritage, the Getty Conservation Institute, and the Australian Heritage Council and issued by China ICOMOS.¹ Senior leaders at the Dunhuang Academy participated in

writing the guidelines and their other applications, notably the Mogao site master plan (see also Fan Jinshi, this volume) and the cave 85 conservation project.

The challenges of preserving the site's 492 decorated cave temples are linked both to its large size and to the complexity of the conservation problems. One difficulty is the nature of the earthen plasters of the polychrome paintings and sculptures, which differs from that of the lime-based plasters that are more familiar to the conservation world. Earthen-based paintings are generally water-sensitive, and therefore the technology and methods developed for treating lime-based paintings are often not appropriate. Because there is relatively little literature on the treatment of earthen-based wall paintings and sculpture, a large component of the project focused on treatment research specific to earthen-based wall paintings.

Cave 85, a late Tang dynasty cave excavated and decorated between 862 and 867 C.E., was selected as representative of the severe and unresolved conservation problems affecting the wall paintings at the Mogao Grottoes (fig. 1). It is one of the larger caves at the site: approximately 350 square meters of painted surface with fourteen illustrated sutras in the main chamber and three sculptures in the central altar (see Wang Jinyu, this volume).

The cave is situated at ground level, midway along the 1.6-kilometer-long cliff face, just north of the prominent Nine-Story Pagoda. The cave temples were excavated into the cliff face, which is composed of soft conglomerate rock. The walls were then plastered and smoothed over with earthen-based plasters and painted with inorganic and organic pigments (for detailed information on cave 85 painting technique, see, this volume, Shekede et al.; Schilling et al.) (fig. 2).



FIGURE 1 Cave 85 (upper level, west side ceiling) during early stages of the project.
Credit: J. Paul Getty Trust

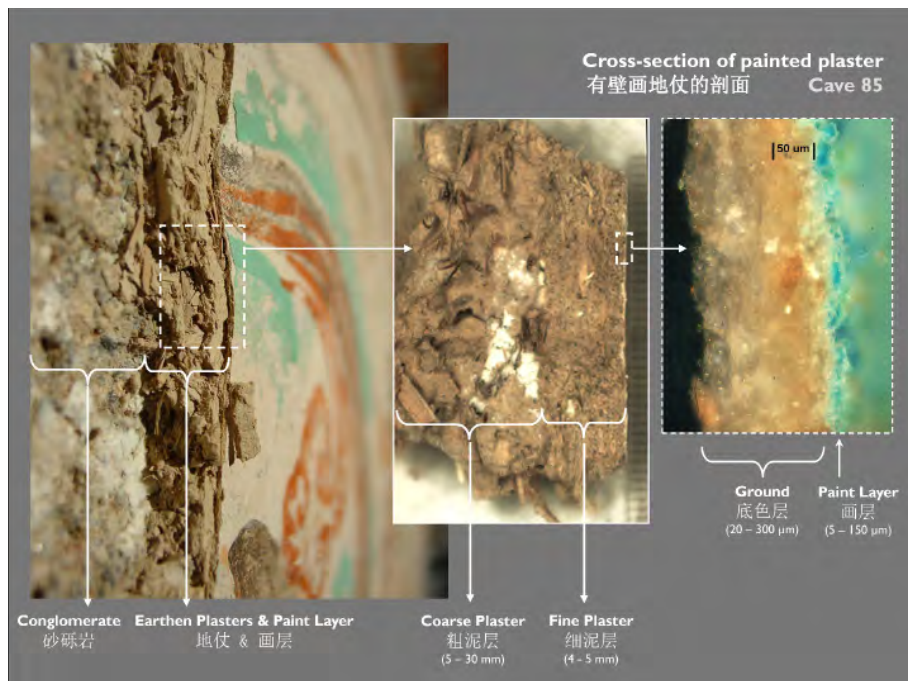

FIGURE 2 Stratigraphy of the painted plaster in cave 85.
Credit: J. Paul Getty Trust

Methodology

The cave 85 conservation plan was developed following a methodological approach based on the China Principles. The philosophical and conceptual approach depends on a statement of the cultural values and significance of the cave in the context of the site as a whole (Demas 2002). Preservation of the cultural significance is the ultimate objective of the project.

The process for the collaborative conservation of cave 85 consisted of five phases: information gathering, assessment, testing and development, implementation, and monitoring and maintenance (table 1). Two field campaigns of joint work, discussion, and information exchange were held at the site per year, in spring and fall. Between campaigns the GCI and the DA teams worked on agreed-on tasks with regular communication, following up on the results of the campaign and in preparation for the next one. Additional training of DA staff took place annually at the GCI in the areas of documentation, treatment testing, instrumental analysis, and environmental investigation. The phases of the project are described below.

Information Gathering

This phase involved research, compilation, and review of background information. An information management system was developed to allow systematic storage and retrieval of project data, including documentation, results, reports, and images (see also Wong et al., this volume). The system allowed quick access to data and facilitated sharing of information between teams.

Table 1 Conservation Process for Cave 85, Mogao Grottoes, Based on the *Principles for the Conservation of Heritage Sites in China*

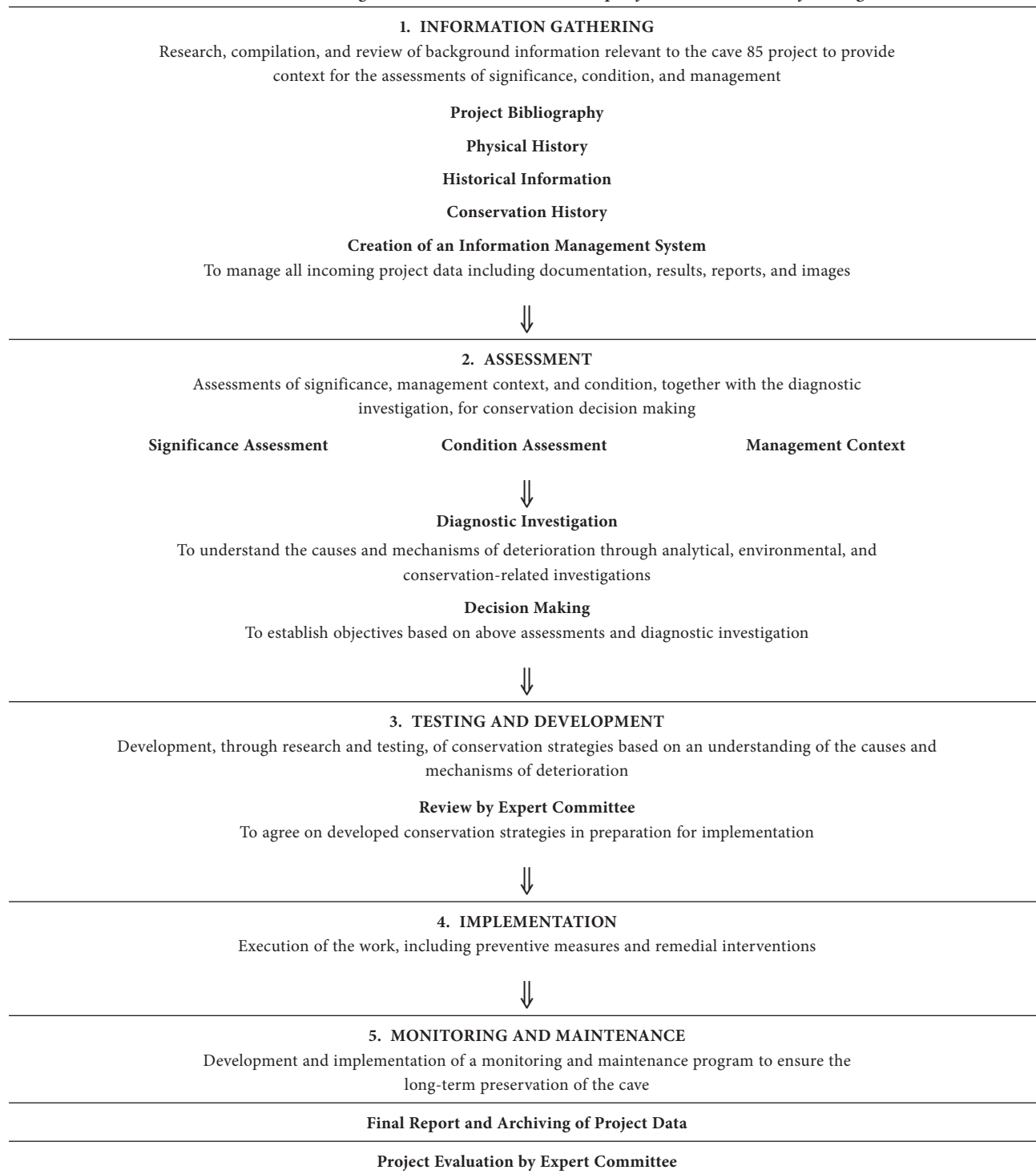

Project Bibliography

A bibliography was started at the beginning of the project and was regularly updated. It covers literature on the site and information on methods and materials used to make and to conserve earthen-based wall paintings. The bibliography exists in hard copy, and an electronic version is being developed as a database searchable by keywords.

Background Information

Information relevant to cave 85 was researched, compiled, and reviewed using archival records, historic photographs, and oral sources:

- Description of the site, including information on geology, hydrology, and climate;
- Information on the physical history and historic context of the site and cave 85, including historic photographs;
- Description of cave 85 and its wall paintings and sculptures, including information on construction techniques and Tang dynasty iconography;
- Conservation information on previous treatments, including type and extent, and generally about conservation practices at the Mogao Grottoes; and
- Visitation history of cave 85, that is, when it was open and closed to the public.

Examination and synthesis of material collected in this phase provided an understanding of the physical and historical changes to the site and their impact on the cave.

Assessment

The assessment phase was central to the methodological process and included research necessary to make decisions about the conservation and use of the cave. This phase involved an understanding of the significance and values of the cave, the management context of the site as a whole, the condition of the wall paintings and sculpture, and a diagnostic investigation of the causes and the mechanisms of deterioration.

Significance

Assessment of significance and the resulting *Statement of Cultural Values and Significance* take into consideration the artistic, historic, social, and scientific values of the site and specifically of cave 85. Significance assessment is an essential component of any project to ensure that the values and sig-

nificance are preserved unimpaired (see Wang, this volume). Preservation of cultural significance is the ultimate objective of the project.

Management

Management assessment involves identification of the constraints and opportunities that may affect the ability of management to preserve and protect a site. The management assessment, undertaken by the project managers, consisted of the following:

- Understanding the management structure responsible for the conservation and maintenance of cave 85; and
- Establishing the responsibilities of the GCI and DA in terms of expertise, budget, and time necessary for the completion and sustainability of the project.

Condition

The condition assessment provided a comprehensive record and understanding of the condition of the wall paintings and sculpture through identification and documentation of the types and distribution of deterioration. This involved the following:

- Detailed visual and instrumental examination of the paintings and sculpture;
- Comprehensive photographic survey of the paintings and sculpture;
- Creation of an illustrated glossary of condition terms; and
- Graphic documentation to map types and distribution of the most significant types of deterioration.

Deterioration phenomena observed in the cave included surface deterioration, such as exfoliation, flaking, and “punctate” eruption of the paint layer, and subsurface deterioration, such as plaster detachment. These phenomena are common in other caves at the site. Deterioration was markedly more severe toward the northwest side of the cave, that is, the rear of the cave (see Xu Shuqing et al., this volume) (fig. 3).

Diagnostic Investigations

The aim of the diagnostic investigations was to understand the causes and mechanisms of deterioration of the wall paintings and sculpture (see, this volume, Agnew et al.; Maekawa et al.). This involved:



FIGURE 3 Details of similar scenes taken from the east and west ends of the south wall illustrating the difference in condition: (a) the paintings at the east, toward the front of the cave, are in near-pristine condition; (b) at the west, toward the back of the cave, they are in poor condition (loss of paint layer and color change).

- Identification of active deterioration processes;
- Establishment and testing of hypotheses of causes and mechanisms of deterioration through
 - study of original and added materials as part of the analytical investigation; and
 - monitoring of exterior and interior climate as part of the environmental investigation.

Identification and Determination of Active Deterioration. The study of documentation collected on the physical history of the cave was useful for identifying active deterioration. When there is active deterioration, repair and strengthening of the object without addressing the causes and mechanism of the deterioration are only a temporary remedy that often causes more damage in the long run (Cather 1999). The two principal types of ongoing deterioration found in cave 85 were exfoliation and detachment. Both conditions had been treated previously and had recurred.

- *Exfoliation:* lifting of paint, ground, and upper plaster layers (fig. 4). This seems to be associated with previous treatments (in the 1970s) for flaking in which polyvinyl acetate and polyvinyl alcohol fixatives were used. Over time, these treatments failed and the conditions returned in most areas.



FIGURE 4 Exfoliation, the lifting of paint, ground, and upper plaster layers, apparently exacerbated by treatments for flaking (in the 1970s) using polyvinyl acetate and polyvinyl alcohol fixatives. The continued loss of painting indicates that this problem is ongoing, most notably at the northwest end of the cave.



FIGURE 5 Detachment, followed eventually by collapse, is a widespread problem. Here, fragments of painted plaster lost from the west slope in 1996 near an anchor installed in the 1970s. Credit: J. Paul Getty Trust

The loss of paint, apparent by comparison of current condition and historic photographs, shows that this problem is ongoing, most notably at the northwest end of the cave.

- *Detachment*: loss of adhesion between earthen plaster and conglomerate rock body. This condition has been a long-term problem and is pervasive at the site. In the 1970s pinning with cross-bracing was used to hold the plaster in place in cave 85. However, this did not address the problem, and it was only a temporary solution. In 1996 a large piece of painted plaster fell from the west slope of the cave during a period of heavy rain (fig. 5). The loss occurred near a metal anchor used to treat the detachment problem thirty years ago.

Paint exfoliation and plaster detachment cause loss of painting on a large scale and therefore are the most severe problems that require intervention. Areas of detachment and exfoliation increase in severity toward the rear, northwest end of the cave, where large losses and anchors indicate a history of problems. Areas of detached plaster are prone to fall under gravity alone, or they are precipitated by seismic shock (Dunhuang is a seismic area) or extended periods of high humidity when hygroscopic salts have absorbed water, causing a weight increase of the plaster.

Cause and Mechanism of the Active Deterioration. The topographic distribution and the specific conditions observed

suggested a deterioration mechanism associated with salts and humidity. It was necessary to obtain a good understanding of the salts present in the paintings and the possible sources of moisture and of its fluctuations in the cave.

Analytical Data. The focus of the diagnostic investigation was the identification and quantification of the soluble ionic species and their distribution within the paintings (see also Schilling et al., this volume). An extensive salt survey of the soluble ion content in the plaster found direct correspondence between the deterioration distribution and salt content, that is, higher ion content toward the west end of the cave, where the condition of the paintings is poorer. The most common salt identified was sodium chloride.

Environmental Data. Environmental data indicated that the cave's microclimate was affected by the climate at the site but that no liquid water was present in the cave (see also Maekawa et al., this volume). In the desert environment the air is generally dry in winter (10–20% RH) and more humid in summer (50–70% RH). Summer rain events can cause the cave's humidity to rise to 80 percent relative humidity or higher. Laboratory experiments show that earthen plaster from the cave begins to absorb moisture at about 67 percent relative humidity. Repeated cycles of water absorption, salt dissolution, and subsequent recrystallization can lead to deterioration; or at prolonged exposure to high relative humidity, to collapse of detached plaster.

The combination of conservation, analytical, and environmental information allowed the formulation of deterioration hypotheses. Deterioration is related to the soluble salts present in the plaster, mainly sodium chloride, and the fluctuations of the cave's relative humidity. Pure sodium chloride absorbs water vapor at a relative humidity of 75 percent and dissolves, a process called deliquescence. Studies have shown that mixtures of different salts, such as occur in cave 85, deliquesce below their individual equilibrium relative humidity values (Nunberg and Charola 2001; Price and Brimblecombe 1994; Sawdy 2003).

The type of deterioration produced by soluble salt activity is dependent on the zone of crystallization: when occurring at the interface between plaster and conglomerate, crystallization can cause detachment (and collapse) of the earthen plaster; when just at the surface, it can cause surface deterioration. Exfoliation, one of the surface deterioration phenomena observed, seems to be also related to both humidity fluctuations and the application of vinyl dispersions (polyvinyl alcohol and acetate) applied in the 1970s to consolidate and fix the painted surface. These film-forming

materials result in lower water vapor permeability of the surface, causing deterioration to occur below.

The assessment phase has important implications for the development of treatment for areas of unstable painted plaster and for the prevention of further detrimental change to the wall paintings.

Testing and Development

Research and testing were undertaken to develop treatment strategies based on an understanding of the causes and mechanisms of deterioration. The conservation plan was a detailed program for implementation of the strategies, and it describes the activities required, their sequence, duration, and needs in terms of human and material resources.

Conservation strategies in this phase included the following:

- Testing and development of preventive measures to mitigate the causes of deterioration by reducing the intrusion of exterior humid air into the cave and, through limited treatment, to reduce salt content in the earthen plaster in certain areas (see Maekawa et al. and Rickerby et al., “Development and Testing,” this volume).
- Establishment of treatment principles, development of remedial treatment to stabilize the paintings through research on treatment materials and methods, design of testing protocols, and evaluation of results. Treatment developed included a grout mixture for the stabilization of detached plaster through injection grouting (see Rickerby et al., “Implementation,” this volume), a gelatin adhesive to fix flaking paint that was selected on the basis of the identification of protein as the binding medium (fig. 6), and an earthen-based plaster to stabilize edges of the wall paintings.

Measures to Mitigate the Causes and Activation of Deterioration

Removal of the principal cause of deterioration, soluble salts, would be the best way to prevent further deterioration. However, desalination of porous materials is rarely a successful operation (Cather 2003). In addition, the fragile condition of the earthen plasters, their sensitivity to water, and the water-soluble nature of the original protein binder made this option impractical. A management decision was made instead to control relative humidity by keeping the

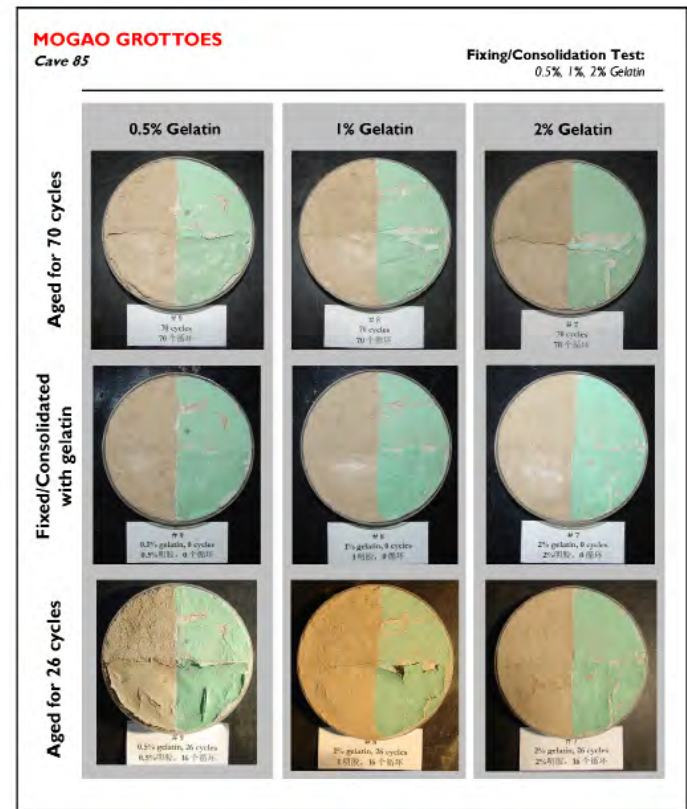

FIGURE 6 Painted plaster disks (loaded with 2% NaCl by wet weight and previously artificially aged for 70 relative humidity cycles [48 hr/100% and 24 hr/ambient RH]) were fixed and consolidated using different amounts of gelatin in water (0.5%, 1%, and 2%). These disks were again cycled to evaluate the performance.

cave doors closed and better sealed during periods of high humidity and rain (fig. 7). This form of passive conservation climate control has been successfully applied to historic buildings (Bläuer Böhm et al. 2001).

Painting Stabilization

Development of interventions to stabilize the deteriorated wall paintings followed the principles of minimal intervention, compatibility, and retreatability and was based on an understanding of the causes and mechanisms of deterioration. Because of the presence of soluble salts in the painted plaster, it was necessary to develop treatments capable of functioning under conditions of high salt content and potential fluctuations in relative humidity. The research, development, and testing of materials with the appropriate properties took several years.



FIGURE 7 Exterior of cave 85 with door closed. A management decision was made to control relative humidity by keeping the cave closed during periods of rain when ambient relative humidity can rise to 75 to 80 percent.

Three main stabilization treatments were developed, as follows:

- Grouting: reattachment of plaster to the conglomerate using a fluid, earth-based mixture with adhesive and bulking properties (see Rickerby et al., “Development and Testing,” this volume).
- Plaster repairs: filling in of lacunae and reinforcement of exposed wall painting edges.
- Fixing and consolidation: reattachment of flaking paint and consolidation of powdering and disrupted conditions associated with exfoliation.

Treatment development and testing started by setting performance criteria and working properties. Performance characteristics relate to the long-term behavior of the materials and measure how the material will function over time; working properties relate to short-term behavior of the material as it is applied and measure its practical ease of use.

To ensure maximum compatibility with the original materials, the clay and silt from the Daquan riverbed were selected as the main binder for the mixture used for plaster fills and grouting. This earth is the same as that used in the original paintings, as confirmed by characterization and particle size distribution of both material from the riverbed and the earthen plaster.² For fixing and consolidation of flakes, pure gelatin in 1 to 2 percent aqueous solution was used.

Implementation

The implementation phase entailed the execution of the conservation strategies, in particular, preventive measures to reduce intrusion of exterior humid air into the cave and remedial interventions to stabilize the paintings and locally reduce soluble salt content. Prior to application on-site, testing and results from treatment development were submitted to an expert committee for approval, a procedure required in China before conservation work can begin on cultural heritage sites of the significance of Mogao.

As part of treatment planning, it was necessary to consider the soluble salts in the plaster that would inevitably be dissolved by the water used in grouting, fixing, and consolidation. Different absorbent materials were tested for use in presses applied after treatment to absorb water and soluble salts and to prevent salt crystallization on the surface of the paintings (see Rickerby et al., “Implementation,” this volume).

Monitoring and Maintenance

A monitoring and maintenance program is necessary to ensure the long-term preservation of the cave after stabilization. Monitoring and maintenance were developed on the basis of the information collected during the project’s diagnostic investigations. The completion of the wall painting conservation program in cave 85 will be followed by regular monitoring and inspection of the condition of the paintings.

The long-term monitoring program is based on post-treatment photographic documentation. Through the conservation project, we were able to identify fourteen representative areas to be monitored, which involves regular inspection to detect any change in condition. DA staff have been trained, and the monitoring areas have been recorded with high-resolution digital photography.

Conclusion

Cave 85 is representative of the remarkable artistic and historic heritage at the Mogao Grottoes and of the site's complex preservation problems. A structured interdisciplinary approach, following the methodology of the China Principles, has been effective in addressing the conservation challenges. Significant steps have been made toward an understanding of the deterioration causes and mechanisms affecting the cave through the collaborative work of the multidisciplinary team. This understanding and the treatment methodology developed have application to other caves at the Mogao Grottoes and at similar Silk Road sites.

This paper presents an outline of the project. Comprehensive details on the analytical and environmental investigations and on testing (flake fixing, grout development, etc.) are available in electronic form in the Cave 85 Project Report of the Getty Conservation Institute and the Dunhuang Academy. Other aspects of the project still in development include recommendations for lighting (see also Druzik, this volume) and a plan for the presentation and interpretation of the cave. Another aspect relates to ongoing research on organic colorants detected on the wall paintings (see Grzywacz et al., this volume).

Acknowledgments

The cave 85 conservation project has been carried out by a multidisciplinary team from the Dunhuang Academy and the Getty Conservation Institute. The authors would like to acknowledge their contribution. Special thanks are due to Neville Agnew and Wang Xudong for direction of the project and refinement of the concepts expressed in this paper. Martha Demas provided guidance and helpful discussion throughout the project.

Notes

- 1 These guidelines are provided online on the Getty Web site: www.getty.edu/conservation/publications/pdf_publications/china_prin_2english.pdf.
- 2 The earthen plaster in cave 85 was made by mixing sand and fibers with the earth from the riverbed.

References

- Agnew, N., and M. Demas, eds. 2004. *Principles for the Conservation of Heritage Sites in China = Zhongguo wen wu gu ji bao hu zhun ze [Chinese-language document] issued by China ICOMOS; approved by the State Administration of Cultural Heritage*. Los Angeles: Getty Conservation Institute.
- Bläuer Böhm, C., K. Zehnder, H. Domaisen, and A. Arnold. 2001. Climate control for passive conservation of the Romanesque painted wooden ceiling in the church of Zillis (Switzerland). *Studies in Conservation* 46: 251–68.
- Cather, S. 1999. Assessing causes and mechanisms of detrimental change to wall paintings. In *Conserving the Painted Past: Post-Prints of a Conference Organized by English Heritage, London, 2–4 December 1999*, ed. R. Gowing and A. Heritage, 64–74. London: English Heritage.
- . 2003. Aqueous extraction of soluble salts from porous materials: Alternatives and contra-indications. In *Mauersalze und Architekturoberflächen*, ed. H. Leitner, S. Laue, and H. Siedel, 167–72. Dresden: Hochschule für Bildende Künste.
- Demas, M. 2002. Planning conservation and management of archeological site: A value based approach. In *Management Planning for Archaeological Sites: Post-Prints of an International Workshop Organized by the Getty Conservation Institute and Loyola Marymount University, 19–22 May 2000, Corinth, Greece*, ed. J. Teutonico and J. Palumbo, 27–54. Los Angeles: Getty Conservation Institute.
- Nunberg, S., and E. Charola. 2001. Salts in ceramic bodies II: Deterioration due to minimal fluctuation in relative humidity. *Internationale Zeitschrift für Bauinstandsetzen und Baudenkmalpflege* 7 (2): 131–46.
- Price, C., and P. Brimblecombe. 1994. Preventing salt damage in porous materials. In *Preventive Conservation: Practice, Theory and Research: Preprints of the Ottawa Congress, 12–16 September 1994*, ed. A. Roy and P. Smith, 90–93. London.
- Sawdy, A. 2003. The role of environmental control for reducing the rate of salt damage in wall paintings. In *Conserving the Painted Past: Post-Prints of a Conference Organized by English Heritage, London, 2–4 December 1999*, ed. R. Gowing and A. Heritage, 95–109. London: English Heritage.

The Role of In Situ Examination in the Technical Investigation of the Cave 85 Paintings

Lisa Shekede, Fan Zaixuan, Francesca Piqué, and Lorinda Wong

Abstract: *The late Tang paintings of cave 85 represent a high point of artistic and technical achievement at Mogao. From the outset of the joint Dunhuang Academy–Getty Conservation Institute conservation project, it was clear that the paintings’ technical complexity demanded a thorough investigation, including scientific analysis, archival research, and detailed in situ examination. The scope of the analytical work was wide-ranging and included earthen plaster components, mineral pigments and their alteration products, organic colorants, and binding media. Analytical techniques ranged from light microscopy to gas chromatography–mass spectrometry. Literature research also contributed important contextual information. This paper focuses on the in situ examination of the paintings, defining the relevance of this crucial but often underestimated aspect of technical study. In situ examination has proved crucial in decision making at every step of the conservation process. It therefore deserves recognition, alongside scientific analysis and archival research, as an essential tool of technical investigation.*

Visual examination plays a primary role in the understanding of painting technology, facilitating the accumulation of an unparalleled range of information with the minimum of specialist equipment. Insights gained through careful and systematic visual examination provide a framework for focused analysis and further research, a role that becomes increasingly important with the complexity of the paintings and their deterioration phenomena. This paper examines the key role of visual examination—using normal and raking light, magnification, and multispectral techniques—as the first source of information for all aspects of cave 85

painting technology and explores these findings in the context of complementary resources such as technical literature and analysis.

Plaster and Molded Earth Applications

All aspects of painting technology were executed by the Tang artists with meticulous precision, including the preparation of the painting support. Two layers of earth plaster were applied to the conglomerate rock walls from which the cave was excavated, each with its own function and characteristics. The first is a leveling layer, its thickness varying (5–30 mm) according to the topography of the walls, composed of earth with characteristics very close to those of the alluvial deposits of the local Daquan River.¹ Sand and coarse vegetable fibers (possibly wheat straw) (Duan Xiuye et al. 1993: 307; Yu 1988: 29) were added to improve its properties. The upper plaster layer is likely to be from the same earthen source and appears to have slightly more added sand. Much finer plant fibers, possibly of beaten hemp, were also added, (Duan Xiuye et al. 1993: 307; Whitfield 1999: 210; Yu Feian et al. 1988: 29). These modifications allowed thinner application (1–3 mm) and a smoother finish.

Examination of the plaster joins in raking light indicates that the walls were plastered first, apparently in a clockwise direction, as a distinct vertical overlap can be seen, for example, where the plaster from the south wall overlaps onto that of the east in the southeast corner. The slopes were plastered next, with a considerable overlap of 30 to 40 centimeters extending down onto the walls. Following plastering, dried, molded blocks of earth plaster were applied to provide three-dimensional embellishments. These could be very

simple, such as the rectangular molded blocks at the west end of the corridor entrance, or more complex, such as the molded lotus petal blocks decorating the sculpture platform. With the plasterers' work completed, that of the painting workshop could begin.

Workshop Structure and Practice

It is clear from variations in painting quality and style that a number of different hands were at work in cave 85, with many of the important elements of the scheme executed with skill and precision and others displaying rough-and-ready application. There is also some evidence that colors—at least those forming the basic paint palette—were applied sequentially, probably by divided labor. These features almost certainly reflect a strict workshop hierarchy, for which there is also substantial documentary evidence. Lists of *jiangren* (artisans) and a *huashi* (painting master) in a Tang dynasty document from Turfan indicate the existence of individual painting workshops and testify to their hierarchical working structures, in which up to seven ranks of personnel may have been employed in the execution of a commission (Fraser 2004: 31–34).

Ground Application

The first undertaking of the painting workshop was the application of the ground.² In cave 85 this is a smooth white layer (100–300 μm) composed of calcite, mica, and talc in an animal glue binder.³ Multiple layers of a pink-tinted wash appear to have been applied over this, probably of composition similar to the ground, with the addition of a red organic colorant. Its color survives best in the eastern part of the cave, gradually diminishing toward the west, a pattern indicative of photo-deterioration.⁴ The setting out of the painting commenced after these preparatory layers had been applied.

Conceptualization and Design Transfer

The symmetry of the compositional framework and the complexity of its individual elements are evidence both of a highly evolved preliminary design and of a sophisticated transfer system. A number of preparatory drawings dating to the ninth and tenth centuries preserved among the Library Cave documents provide unique insights into this process.⁵ These rough working drawings, some containing technical and logistical instructions, range from schematic large-scale

designs for entire portions of wall decoration to detailed studies of individual scenes (Fraser 2004: 49).

To transfer these rough sketches, the walls would first have been measured and divided up to accommodate them. Although signs of this have not been found, there is substantial evidence for the setting out of smaller-scale compositional details. Direct, straight-edge incisions—characterized by thin, sharp lines—were used to delineate the spacing of the “beaded pearl” design of the ceiling caisson, to set out text cartouche outlines, and to form guidelines for the texts themselves. Compass incisions were used for setting out haloes, mandorlas, and the beaded pearl decoration on the ceiling (fig. 1).

Cartoons are known to have been used for design transfer during the Tang dynasty, and a number of paper pouncing cartoons from the period survive from the Library Cave cache (Fraser 2004: 49). In cave 85 possible traces of indirect incisions on one of the principal figure compositions—characterized by wide, shallow lines—are too partial and indistinct to constitute firm evidence for cartoon use. It is also clear, from measurements taken of repeat motifs in foliate borders, that cartoons were not used here either. Despite this, the more extended use of cartoons cannot be ruled out, as evidence of pounces, like most of the other preparatory evidence, may simply have been covered over by successive paint layers.



FIGURE 1 Fine straight-edge incisions in the ground layer provide guides for the painted design on the ceiling caisson. Photo: Rickerby/Shekede 2004

Preliminary Drawing

Although evidence for preliminary drawing has largely been obliterated by subsequent paint applications, very dilute black brushwork can still be seen in areas where the painting was accidentally left incomplete. It is probable that most elements of the composition were similarly delineated.

Paint Preparation and Application

The palette of cave 85 is extremely rich, and the diversity of effect is enhanced by skillful paint preparation and application techniques. Over the centuries the deleterious effects of light, humidity, and salts have resulted in color fading, alteration, and paint loss, and although the scheme now appears dominated by green, white, and dark red, careful visual examination of the less deteriorated areas shows that colors susceptible to change—including bright blues, reds, purples, and yellows—were originally important chromatic elements of the painting (figs. 2, 3).

Analysis undertaken during the project has identified a number of paint materials derived from naturally occurring mineral deposits including calcite, mica, talc, orpiment, atacamite, azurite, and iron oxide red. Pigments obtained through chemical and other processes include carbon black, lead white, red lead, and vermilion.⁶ Gold foil was used in cave 85 but very sparingly, being reserved for remarkably small details in the center of the ceiling caisson and on the Sakyamuni statue base. There is also extensive evidence for the use of a range of organic colorants in cave 85 (see below).

Colors were applied in organic binding media.⁷ It is evident from the extraordinary thinness of most paint layers—even those containing very coarsely ground particles—that the medium-to-pigment ratio is high. While this enabled mineral pigments to be applied as semitranslucent glazes, it also made paint susceptible to runs, much evidence for which can be seen in cave 85. Impasto execution is restricted to fine details such as jeweled headdresses, halo patterning, and harness studding.



FIGURES 2 AND 3 Pigment alteration and degradation of organic components is far more severe to the west and north of the cave, clearly demonstrated by comparing a scene on the north wall (left) with a similar scene on the less affected south wall (right). Photos: Rickerby/Shekede 2004

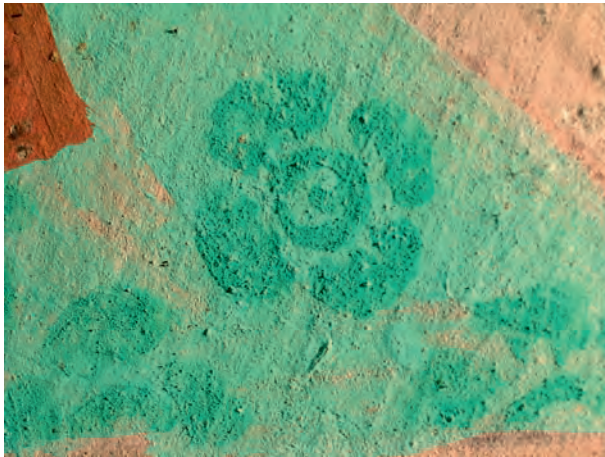

FIGURE 4 A coarse grade of atacamite green superimposed on a finer grade in the depiction of brocade. Photo: Rickerby/Shekede 2004

Examination of areas of the painting where upper layers have been lost provides information on the color range and sequencing of primary paint applications. A narrow range of preliminary colors—chiefly a dull red (red iron oxide), pale green (atacamite), and black (carbon black)—were blocked in first, probably by the lower ranks of the workshop hierarchy (Fraser 2004: 34) (fig. 2). A much broader palette was used for the subsequent layers, from which an incredible variety of effects were obtained (fig. 3). Pigments were used singly or in combination, as washes or in impasto, ground to different particle sizes, combined with organic colorants, and modulated by organic glazes, all following a standardized procedure.

The technique of blending colors on the wall without the use of outlines, sometimes referred to as the “boneless method” (Yu Feian et al. 1988: 52), was used for representing features of diffused color and indistinct form. Extremely sophisticated effects are achieved in cave 85 by superimposing multiple thin, translucent washes of color. Tang dynasty artists exploited this technique to evoke poetic mountain scenery in the so-called blue-and-green (*qinglü shanshui*) style of landscape painting (Zhuang Jiayi and Nie Chongzheng 2000: 42–47), a very accomplished example of which can be seen on the Jataka of Prince Sudana and the Tigers scene on the east wall.

One of the subtlest and most inventive uses of color is achieved by exploiting variations in the optical properties of certain minerals when they are ground to different sizes.

Paint layers composed of coarser particles are thicker, darker, and more intense, whereas those composed of finer particles are thinner, lighter, and more translucent. In cave 85 up to three different grindings of atacamite, azurite, and vermilion can be discerned by color intensity and, in raking light, by the texture of the paint layers. For example, in the depiction of brocade fabrics, a thin wash of finely ground pigment (either azurite or atacamite) is applied as the background color, and then the pattern is picked out in a sparkling, richly colored impasto composed of large particles of the same pigment (fig. 4). The light, delicate greens of tree bark, branches, and leaves, especially the pale gray-greens of willow, are vividly realized by layering the most finely ground grades of atacamite. This practice has a long history in China, having been observed on Qin dynasty wall paintings in Shaanxi province (Liu Qingzhu 1980: 98–99).

Colored Organic Glazes

A wide range of organic colorants are known to have been available to Tang dynasty artists, but until relatively recently their use has been associated almost exclusively with painting on paper and silk, and investigations into their use in Mogao wall paintings have been omitted from almost all technical studies. This is due in part to their limited survival in this context (organic glazes are susceptible to numerous agents of deterioration, most notably light) and in part to the fact that the analytical identification of organic colorants, especially when aged and highly deteriorated, is notoriously problematic. Careful observation reveals, however, that their use was extensive in cave 85. (See also Grzywacz et al., on Asian organic colorants, this volume.)

Traces of colored organic glazes are virtually absent at the western end of the cave, whereas at the eastern end—which has suffered less from salts-related deterioration and light exposure—the original scheme is much better preserved. The most evident organic colorant is a rich, dark purplish red (fig. 5). A variety of effects were achieved by glazing over different opaque layers: over white, it produces a vivid light plum color; over black, a deep, rich, wine red results; mixed with yellow and applied over black, it gives an orange-red; applied over vermilion, it produces a deep, rich pink. The intent behind other applications is much less readily interpreted. For example, an organic red applied to modulate flesh tones is visible only as saturated, darkened patches on cheeks, necks, fingers, and abdomens, in some places so deteriorated that it can be seen only



FIGURE 5 The rich purple-red organic glaze on a decorated halo survives at the east end of the south wall, but few traces have survived toward the west end of the cave due to light exposure and other environmental factors. Photo: Rickerby/Shekede 2004

in UV-induced fluorescence (figs. 6, 7).⁸ Problems in the detection and analysis of many of these fragile materials ensure that their nature and purpose will continue to remain elusive.

There is considerable literary evidence for the use of organic colorants in Tang dynasty painting. The contemporary writer Zhang Yanyuan refers to the use of “ant ore,” which is almost certainly the red organic colorant lac (*Coccus lacca*; Pinyin, *chong jiao*). This was produced beyond China’s southwestern borders and is known to have been imported into the country from an early date (Yu Feian et al. 1988: 12). Safflower (*Carthamus tinctorius*; Pinyin, *honghua/honglanhua*), also widely used, produced an orange-red colorant when treated with an alkali (Gettens and Stout 1966: 154). Library Cave documents attest to its use at Mogao: they record donors offering “honglan” for decorating the caves (Wang Jinyu, pers. com.). Madder (*Rubia tinctorum/R. cordifolia*; Pinyin, *qian cao*) grew wild across northwestern China, from which a rich pink dye was extracted (Yu Feian et al. 1988: 11). These three plant dyes were the most commonly used components in the preparation of “rouge,” which was used both as a cosmetic and as a painting material (Yu Feian et al. 1988: 12). Such com-



FIGURES 6 AND 7 The rosy flesh tones of these chubby boy acrobats, no longer visible in normal light (left), seem to have been achieved using organic glazes, but these can now be seen only in UV-induced fluorescence (right). Photos: GCI 2004

pounds are known to have been available at Mogao, through the presentation of “eight jins of good quality rouge” by a Dunhuang military commander to a local Uyghur chief, documented in Library Cave manuscripts (Wang Jinyu, pers. com). In addition to its use as a color modulator, the application of rouge over vermilion probably had the advantage of lessening the incidence of color change in the latter (Ippolito 1985: 97). Purple colorants were produced from logwood, also called sappanwood (*Caesalpinia sappan*; Pinyin, *su mu*) (Li Ch’iao Ping 1948: 141; Yun Ye, Salmon, and Cass 2000: 248; Yu Feian et al. 1988: 13), and gromwell (*Lithospermum erythrorhizon*; Pinyin, *zi cao*) (Yun Ye, Salmon, and Cass 2000: 246).

Traces of at least two different yellow organic colorants can be observed in cave 85: a dark, rich, glossy yellow-brown, used mainly in the depiction of clouds, and a much paler, dull yellow, traces of which have been detected in architectural detailing, such as counterchanged brickwork and roof tiling. Both may be considerably altered from their original appearance, and it is likely that organic yellows were much more widely used in the cave than is now apparent. Certainly their conspicuous near-absence from the cave contrasts strongly with their abundant presence in Tang paintings on silk and paper.

Numerous yellow dyes were available to Tang dynasty artists. Safflower, described above, produced not only a red dye but also a golden yellow when prepared on an alum mordant (Yu Feian et al. 1988: 11). One of the yellow colorants on the Tang dynasty Diamond Sutra has been identified as amur corkwood (*Phellodendron amurense*; Pinyin, *huang bai*), a bright yellow bark extract originating in Sichuan province (Bell et al. 2000: 234). Rattan, also called gamboge (*Garcinia hamburyi*/*G. morella*; Pinyin, *teng huang*), a colorant indigenous to India, Sri Lanka, and Thailand, was known to have been imported to China before the Tang dynasty (Gettens and Stout 1966: 114–15; Feian Yu et al. 1988: 13). The pagoda tree (*Sophora japonica*; Pinyin, *huai hua*), known to have been in cultivation by the fifth century, yielded a yellow dye that was used with malachite for the specific purpose of improving its adhesion (Ippolito 1985: 89–90; Li Ch’iao Ping 1948: 141). According to the Yuan dynasty author Li Kan, two separate decoctions were prepared from its buds and the petals and used to add luster to different grindings of the pigment. Other available organic yellows include gardenia seed extracts (*Gardenia jasminoides* Ellis; Pinyin, *zhizi*) (Yu Feian et al. 1988: 14; Yun Ye, Salmon, and Cass 2000: 246).

Selective Organic Coatings

Some organic coatings appear to have been applied not primarily to modulate the color of underlying opaque layers but to fix and enrich them. In cave 85 a saturated halo can often be seen around the perimeters of forms painted in atacamite green, which often appear blurred and indistinct. The juice of sticky pearlwort (*Sagina maxima*; Pinyin, *shu yang quan*) was recorded by a Tang dynasty author as being applied over pigments, particularly greens, in order to enrich them and improve adhesion (Yu Feian et al. 1988: 19), and it is possible that extracts of sticky pearlwort—possibly of pagoda tree derivatives (see above)—were mixed with or applied over atacamite green paint layers in cave 85.

Preferential coatings are also visible on some red text cartouches, from which gas chromatography–mass spectrometry (GC-MS) analysis has identified fruit gum. These have a saturated and glossy appearance, and many also have a preferentially exfoliating surface. The purpose of these applications was perhaps to protect, add luster, or improve legibility of scriptures and other texts.

Final Drawing

During the Tang dynasty, the final delineation of objects became an increasingly important stage of the painting’s execution and would have been carried out by the most senior members of the painting workshop (Barnhart 1997: 83–85). Extremely refined and economical drawing can be observed in cave 85. Both black and red were used for this purpose and would have been applied using the same bamboo- and animal-hair brushes as those used by calligraphers, whose mastery of line was equally prized (Zhuang Jiayai and Nie Chongzheng 2000: 16–17) (fig. 8).

Conclusion

The investigation of wall painting technology is always restricted by the limitations of available resources. For cave 85, despite the investigative resources of a long-term, multidisciplinary conservation program, the complexity of both the paintings and their deterioration remains a formidable obstacle to their complete understanding. Important aspects of technique and condition elude both analytical detection and interpretation, and their significance is not always recognized. Degraded organic components continue to challenge the detection limits of currently available



FIGURE 8 Sinuous and highly controlled line drawing from an especially fine figure group on the south wall. Photo: Rickerby/Shekede 2004

analytical methods. Although contemporary documents offer fascinating glimpses of workshop practice and the use of materials, they remain silent on many of these issues. With these limitations in mind, this paper has demonstrated the versatility of in situ visual examination as a means of exploring aspects of painting technology—from the broadest patterns to the most minute phenomena—that cannot be done by any other means.

Notes

- 1 For the results and discussion of earthen analysis, see Rickerby et al., “Development and Testing,” this volume.
- 2 This may have been preceded by the application of a glue and alum sealant, a practice referred to in the literature (Lu Hongnian 1956: 15–17; Feian Yu et al. 1988: 18). Although there is no visual or analytical evidence for this, its use over the ground and subsequent layers is suggested by GC-MS and SEM analysis (Schilling et al., this volume).
- 3 The results of paint analysis are discussed in Schilling et al., this volume.

- 4 Although light levels in the cave are currently low, the historic shearing of the cliff face and loss of the front chamber left the paintings exposed for a prolonged period, until the current facade was built in 1963–64. In any case, the severity of photo-deterioration is determined not only by light intensity but also by exposure time (Gowing 2003: 91–92).
- 5 Cave 17, known as the Library Cave due to the enormous number of documents found there, was rediscovered in 1900 after having been sealed in the eleventh century. For further information, see Whitfield, Whitfield, and Agnew 2000: 121–31.
- 6 See note 3. It is unclear whether naturally occurring cinnabar or the artificially produced pigment, vermilion, was used in cave 85. Either is possible, as cinnabar occurs naturally in southern China, while dry-process vermilion, thought to have been invented in China, was in production at a much earlier date (Gettens, Feller, and Chase 1993: 160–61).
- 7 GC-MS analysis indicates that animal glue was the most extensively used binder, but plant gums and mucilage may have also been used for some applications. See note 3.
- 8 Successful imaging of organic components and underdrawing was undertaken by Lorinda Wong and Francesca Piqué using GCI-supplied MuSIS™ multispectral imaging equipment, operating across 380–1,000 nm.

References

- Barnhart, R. M. 1997. *Three Thousand Years of Chinese Painting*. New Haven, CT: Yale University Press.
- Bell, S. E. J., E. S. O. Bourguignon, A. C. Dennis, J. A. Fields, J. J. McGarvey, and K. R. Seddon. 2000. Identification of dyes on ancient Chinese paper samples using the subtracted shifted Raman spectroscopy method. *Analytical Chemistry* 72 (1): 234–39.
- Duan Xiuye, Li Jun, Guo Hong, and Li Tiechao. 1993. Report on the analyses of pigments found in caves no. 232 and no. 35 at the Mogao Grottoes, Dunhuang. In *Dunhuang yan jiu wen ji [Dunhuang Studies]*, Dunhuang yan jiu yuan (China), 2:107–20, 307–8. Lanzhou: Gansu min zu chu ban she.
- Fraser, S. E. 2004. *Performing the Visual: The Practice of Buddhist Wall Painting in China and Central Asia, 618–960*. Stanford, CA: Stanford University Press.
- Gettens, R. J., R. L. Feller, and W. T. Chase. 1993. Vermilion and cinnabar. In *Artists' Pigments: A Handbook of Their History and Characteristics*, ed. R. Ashok, 2:159–82. Washington, DC: National Gallery of Art.
- Gettens, R. J., and G. L. Stout. 1966. *Painting Materials: A Short Encyclopaedia*. New York: Dover Press.
- Gowing, R. 2003. Investigating the use of a CCD camera system for monitoring insolation of painted architectural surfaces. In *Conserving the Painted Past: Developing Approaches to Wall*

- Painting Conservation: Post-Prints of a Conference Organised by English Heritage, London, 2-4 December 1999*, ed. R. Gowing and A. Heritage, 85-94. London: James & James.
- Ippolito, J. M. 1985. Chinese paint pigments and their classification, with an examination of the four Ming dynasty paintings at the Seattle Art Museum. Master's thesis, University of Washington.
- Li Ch'iao Ping. 1948. *The Chemical Arts of Old China*. Easton, PA: Journal of Chemical Education.
- Liu Qingzhu. 1980. [Preliminary discussion on the art of the wall paintings of the No. 3 palace building in the ruins of the Qin capital, Xianyang, Shaanxi province]. *Kao gu yu wen wu = Archaeology and Cultural Relics* 2: 98-99.
- Lu Hongnian. 1956. [Notes on the methods of painting walls in China]. *Wen wu can kao zi liao = Journal of Museums and Relics* 8: 15-17.
- Whitfield, R., S. Whitfield, and N. Agnew. 2000. *Cave Temples of Mogao: Art and History on the Silk Road*. Los Angeles: Getty Conservation Institute and the J. Paul Getty Museum.
- Whitfield, S. 1999. *Life along the Silk Road*. London: John Murray.
- Yu Feian et al. 1988. *Chinese Painting Colors: Studies of Their Preparation and Application in Traditional and Modern Times*. Hong Kong: Hong Kong University Press; Seattle: University of Washington Press.
- Yun Ye, L. G. Salmon, and G. R. Cass. 2000. The ozone fading of traditional Chinese plant dyes. *Journal of the American Institute for Conservation* 39 (2): 245-57.
- Zhuang Jiayi and Nie Chongzheng. 2000. *Traditional Chinese Paintings: Silent Poems in Praise of Nature and Human Life*. Beijing: China Intercontinental Press.

Analytical Research in Cave 85

Michael R. Schilling, Joy Mazurek, David Carson, Su Bomin, Fan Yuquan, and Ma Zanfeng

Abstract: *The project to conserve the wall paintings in cave 85 at the Mogao Grottoes presented many analytical challenges that taxed even the most sophisticated laboratory instrumentation. The first, and often overlooked, aspect of the process was a careful in situ examination of the wall paintings by an experienced conservator for the purpose of selecting the samples. Next, the analytical tools for the studies were selected on the basis of versatility and detection limit. Organic binding media were identified using gas chromatography–mass spectrometry and Fourier transform infrared spectrometry. Dispersions of pigment particles were examined by polarized light microscopy. Inorganic pigments were identified using X-ray diffraction, whereas organic pigments were analyzed with liquid chromatography–mass spectrometry and thin-layer chromatography. The reflectance spectra and lightfastness of organic pigments were studied by microfadeometry. Examination of paint cross sections revealed information about the layering and materials; elemental distributions in the paint layers were studied using scanning electron microscopy and energy-dispersive X-ray spectrometry. Water-soluble salts were analyzed by ion chromatography and by ion-selective electrodes. For decisions about the order of application of multiple analytical techniques, the quantity of available sample was the key consideration. Final compilation of the corpus of analytical test results into a database not only was useful for the purposes of archiving and sharing information but also gave the additional benefit of greatly facilitating data interpretation. Implementation of this systematic analytical approach in cave 85 revealed a level of complexity in the wall paintings that was not previously imagined. This paper discusses selective results and findings from each major area of analytical*

investigation and the organizational structure of the project's analytical database.

In the project to conserve the wall paintings in cave 85, material analysis played a critical role in three major project areas: (1) studying the artists' materials and painting technique, (2) seeking to understand the causes of deterioration of the wall paintings, and (3) assessing the content and distribution of hygroscopic salts in the paint, plaster, and conglomerate rock. Analytical research in these project areas involved characterization and identification of a wide variety of materials: inorganic and organic pigments, organic binding media, water-soluble salts, earthen plaster, and plant fibers. To accomplish these objectives, numerous analytical techniques were employed and new sample preparation procedures developed or refined as needed. Except for a few samples sent to outside laboratories for specialized tests, the majority of analyses were carried out in the scientific laboratories of the Dunhuang Academy and the Getty Conservation Institute (GCI).¹ Implementation of this systematic analytical approach in cave 85 revealed a level of complexity in the wall paintings that was not previously known.

Materials and Technique

The rough-hewn conglomerate walls of the grottoes are covered with two layers of earthen plaster: a coarse underlayer and a fine upper layer. Particle size analysis of the earthen material revealed a composition of 36 percent sand, 45 percent silt, and 19 percent clay. The bulk minerals were identified in decreasing order of abundance as quartz, dolomite,

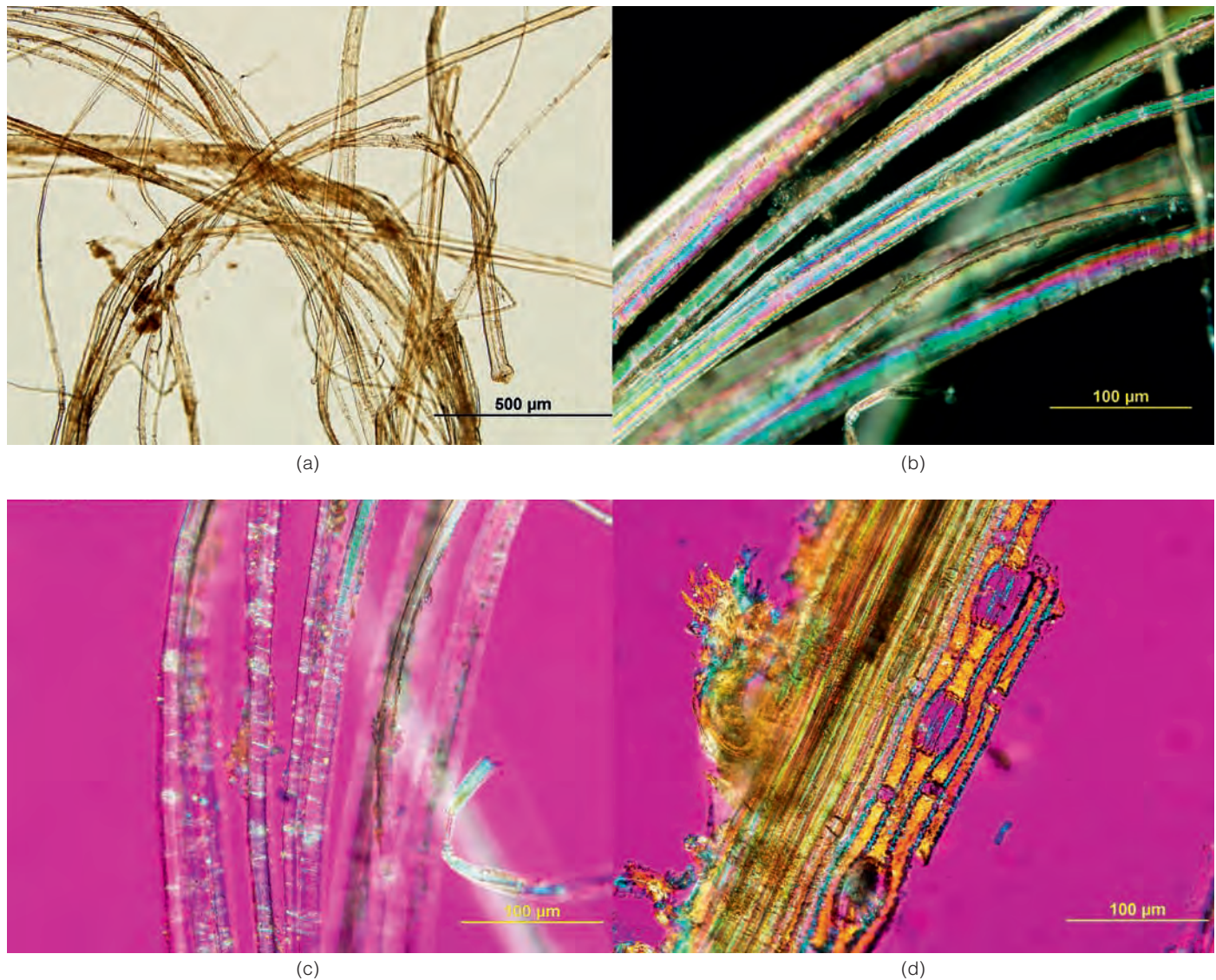

FIGURE 1 Photomicrographs of plant fibers from the upper and lower plaster layers.

calcite, orthoclase feldspar, and plagioclase feldspar. The clay-size fraction consists of 40 percent illite, 30 percent chlorite, and 30 percent mixed-layer illite/smectite (Austin 1998). Sodium chloride, originating from the hygroscopic salt mixture present in the conglomerate, was detected by XRD in a small number of plaster samples with unusually high salt content.

Natural plant fiber bundles from the fine upper plaster layer, shown using a 10× lens with single-polar illumination (fig. 1a) and a 40× lens using crossed-polar illumination (fig. 1b), are typical of untreated bast fibers. In figure 1c, the fibers are oriented perpendicular to the polarizer with a first-

order compensator inserted, and the faint blue colorization in this orientation is a feature of positive (z-twist) natural fibers, of which there are many. Natural plant fiber fragments from the coarse lower plaster layer appear more like tubular cereal grass (fig. 1d); the edge of one of the pieces shows the serrated cells and what appear to be stomata. Considering the absence of other key morphological features and lacking knowledge of species distribution in China, it was not possible to specify the plant species further (Bisbing 2006).

Analysis of pigments in the wall paintings afforded a few surprises. In general, the mineral pigments identified in cave 85 using PLM, XRD, and ESEM-EDX were consistent

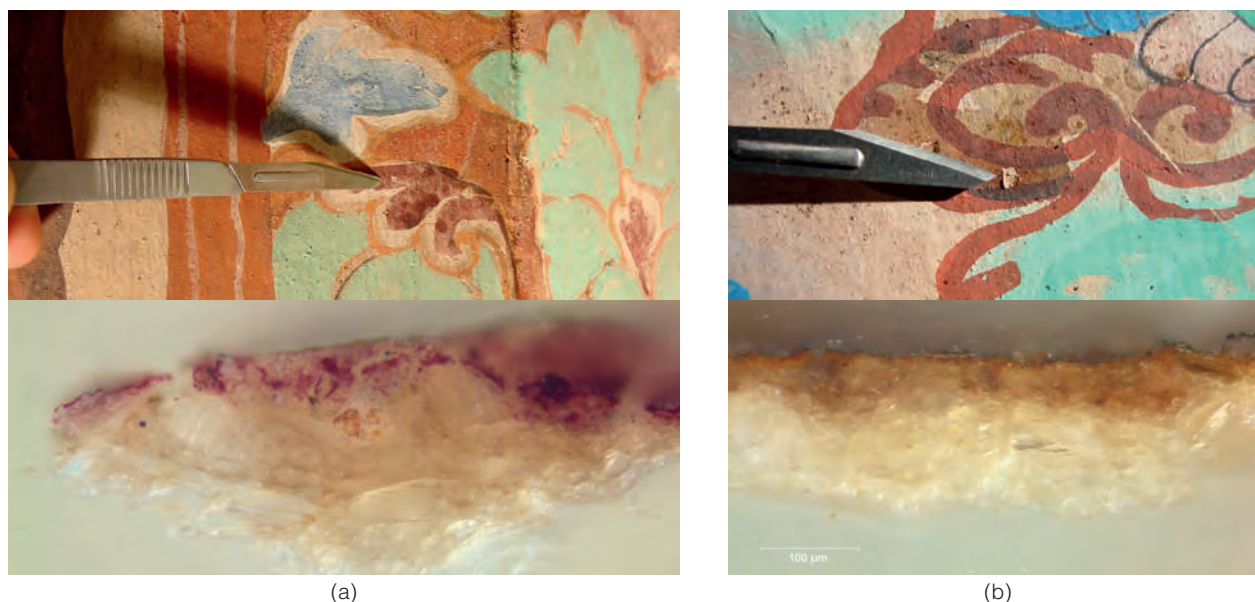

FIGURE 2 (a) Reddish purple color from a decorative border on the east wall with inset darkfield photomicrograph of paint cross section (sample F03S01); (b) translucent brown from cloud on south wall with inset darkfield photomicrograph of paint cross section (sample F03S21).

with numerous technical studies of the Mogao Grottoes wall paintings (Guo Hong 1997; Wainwright et al. 1997; Wang Junhu, Li, and Schilling 1995). To summarize the findings, the fine earthen plaster is covered by a white ground layer from 20 to 200 microns in thickness composed of calcium carbonate, mica, and talc; the ground layer exhibited weak UV fluorescence in paint cross sections. Numerous inorganic pigments were detected in the wall paintings, such as azurite, malachite, atacamite, red lead, cinnabar, red iron oxide, yellow ocher, white lead, orpiment, and carbon black. Black lead, or plattnerite, was also identified as a product from transformation of red lead and white lead pigments. Overall, paint layers ranged in thickness from 5 to 100 microns.

The conservation team noted a number of shades of color on the wall paintings that could not have been produced from admixtures of the common Tang dynasty mineral pigments. Readily observed on the slopes, upper walls, and ceiling panel in locations that are shaded from direct sunlight exposure via the opening to the cave, many of these colors fluoresced strongly under UV light. One example is a reddish purple color from a decorative border around the walls and slopes (fig. 2a). In a cross section from this area, the paint appears as minute red particles smeared onto the white ground. ESEM-EDX analysis of this cross section shows an absence of elements associated with typical red mineral pigments (e.g., iron, mercury, or lead) and instead a slight

enrichment in aluminum and potassium. These elements are consistent with the use of alum for precipitating dyestuffs in the manufacture of organic pigments and also with the application of a preparative glue sizing layer (Yu Feian, Silbergeld, and McNair 1988; Shekede et al., this volume).

Given the widespread usage of organic colorants in cave 85 and in other caves, it is surprising that few publications mention the use of these important artists' materials in the context of Mogao (Xu Weiye, Zhou Guoxin, and Li Yunhe 1983). One contributing factor is that conventional techniques that work so well for identifying mineral pigments are incapable of detecting organic materials of any sort. Detection and identification of traditional Chinese organic colorants present an additional challenge not only because many of the biological sources used to create them have not been well studied but also because in the case of organic paints concentrations of these colorants are low compared with those of inorganic pigments and binding media. Much less is known of these colorants than of the dye and organic pigment sources used in Europe and the Americas. Moreover, organic pigments can become unrecognizable due to fading or darkening in the more easily accessible areas of the wall paintings. Thus even if suitable organic pigment standards were available, the analytical results for fresh and aged pigments might differ substantially. To address these issues, research is currently under

way to investigate the identification of organic colorants in Asian wall paintings (see Grzywacz et al., this volume).

Identification of the organic binding media proved more complex than anticipated, due to the presence of organic colorants in many of the paint samples. With FTIR, no paint media were detected in paint and ground samples above the instrumental detection limit of 5 to 10 percent by weight. However, many spectra showed characteristic infrared (IR) bands for oxalates. These include intense bands at $1,622\text{ cm}^{-1}$ and $1,320\text{ cm}^{-1}$, plus medium-intensity bands at 780 cm^{-1} and 668 cm^{-1} , for the dipole moment of the carboxylate group stretching. Bands at $1,622\text{ cm}^{-1}$ and $1,320\text{ cm}^{-1}$ are due to the asymmetrical and symmetrical carboxylate group stretching, respectively. Oxalates are formed from chemical and microbial conversion of organic materials but are also commonly present in the tissues of plants that thrive in arid climates (Wainwright et al. 1997).

An earlier study of binding media in the wall paintings of Mogao, using liquid chromatography to analyze amino acids in acid hydrolysates of 2-milligram paint samples, clearly demonstrated that collagen-based proteinaceous materials such as animal glue were used in the majority of the caves surveyed. In contrast, the amino acid compositions of the remainder of the samples correlated somewhat broadly to fruit gums; in these polysaccharide-based materials, amino acids are present in the form of glycosides (Li Shi 1995), although no mention was made of the existence of organic colorants in the paintings.

To identify the binding media in cave 85, paint samples (in the submilligram range) were prepared for quantitative GC-MS following protocols developed for identification of protein and polysaccharide binding media in easel paintings (Schilling 2005). Both procedures involve an acid hydrolysis step to depolymerize the media, followed by chemical derivatization to produce volatile analytes suitable for GC. Proteinaceous binding media were identified on the basis of amino acid composition (Schilling and Khanjian 1996a, 1996b), and plant gums on the basis of carbohydrate composition (Schilling 2005). Compositional data were evaluated using correlation coefficients and principal component analysis, which are two common statistical evaluation tools (Columbini et al. 1998; Schilling and Khanjian 1996b). Of the twenty-six samples tested for carbohydrates, only fourteen were analyzed for amino acids due to limits on sample quantity. Table 1 lists the results from the quantitative GC-MS analysis of amino acids and carbohydrates.

For eleven samples, the amino acid composition matched collagen unambiguously, with a correlation coef-

ficient exceeding 0.8 for each sample. The amino acid composition of two samples (NQ01PE11 and YDNQ01PE14) correlated more closely with that of a white residue that was formed by microbial activity between the conglomerate and the earthen plaster. The residue was initially thought to be hygroscopic salt, but microscopic examination instead revealed a mass of microbial hyphae. The binding medium in only one sample (BP00PE9) could not be identified because the amino acid content was, essentially, at the experimental detection limit of 0.1 weight percent. It is clear from these data that a collagen-based material such as bone glue or hide glue was the principal binding medium used in cave 85.

In studies of Western easel paintings, it is often relatively easy to identify plant gum binding media because only a few gums were in common usage (gum arabic, gum tragacanth, and prunus gum). Concerning the GC-MS tests for carbohydrates in cave 85, eighteen of the samples tested had total carbohydrate contents exceeding 0.1 percent by weight, but the compositions proved unusually variable. Many of the samples contained glucose and fructose, with smaller amounts of other carbohydrates typically present in plant gums and mucilages. Fructose and glucose, two sugars that are not common in fruit gums, may originate from several sources. Fructose is relatively abundant in honey, but it is also present in plant mucilages such as in *Eremurus* root, which has been reported in a study of central Asian art (Birstein 1975). Plant fibers added to the plaster contribute carbohydrates, primarily glucose but also xylose, on chemical degradation. Therefore, if one ignores the content of fructose and glucose in the samples and interprets the data for the remaining carbohydrates, a few of the paints correlated closely with apricot gum (sample DP98PE12), gum tragacanth (NQF03S24), and even gum arabic (PLATXQ98P2). In each of these samples, however, the concentration of fucose and/or mannose did not match with these plant gums at all, thus making the identification of gums in the paints somewhat suspect.

Interpretation of the carbohydrate data for the cave 85 paint samples was further complicated by several factors. First, organic colorants naturally contain carbohydrates in the form of glycosides, which contribute to the overall carbohydrate composition of the paint. Moreover, the artists may have applied other carbohydrate-containing materials besides fruit gum, such as plant mucilages. Finally, interferences from mineral pigments and physical aging may affect the carbohydrate composition of the paint media. Considering all these factors when attempting to draw conclusions about the sources of carbohydrates in the cave 85 paint samples, it

Table 1 Summary of GC-MS Quantitative Analysis Results of Paint Samples from Cave 85

Sample	Description	Normalized Mole Percentages										Normalized Weight % of All Carbohydrates									
		Amino Acids	Ala	Val	Ile	Leu	Gly	Pro	Hyp	Sugars	Rham	Fuc	Rib	Arab	Xyl	Mann	Fruct	Glu	Gal		
JXDB00P1	Organic red	5.9	13	5.7	4.0	6.6	6.1	7.8	1.8	0.77	0.7	0.4	0	5.4	2.2	1.8	17	69	4.3		
YDNQ01PE14	Gray	2.6	21	12	9.3	18	22	11	6.7	0.76	0.5	0	2.1	64	1.1	0	30	2.4			
NP.F03.S29	Dark red	0.8	14	3.1	2.7	3.5	44	18	15	<0.1											
NQ.F03.S24	Brown-resinous	0.7	16	8.8	7.3	8.2	21	19	20	0.40	1.0	0	41	6	4.0	4	26	10			
DQ00PE16	Red & ground	0.4	17	3.7	2.9	4.9	31	25	16	0.23	0	0	2.5	3.2	0	35	58	0.6			
NQ.F03.S25	White	0.4	20	6.6	4.3	5.7	35	18	11	<0.1											
NP.F03.S22	Pink	0.4	15	3.6	2.7	3.7	41	16	19	<0.1											
NQ.F03.S08	Red	0.4	17	5.9	5.1	6.1	45	12	9.3	<0.1											
JXNB01PE13	Discolored ceiling	0.39	19	3.6	2.0	4.1	48	15	8.6	0.12	1.1	0	2.7	1.6	2.2	16	73	3.2			
DP.F03.S17	Brown	0.3	16	9.6	6.9	10	40	13	4.2	<0.1											
DQ00PE15	Blue & ground	0.22	20	6.1	4.1	7.6	26	18	18	0.10	0.4	0	7.2	7.0	0	22	60	3.3			
NQ01PE11	Colored ground	0.12	24	7.6	5.5	12	38	12	0.0	2.6	0	0	5.4	18	0	0	71	6.2			
BP00PE9	White	0.12	14	7.0	7.5	13	13	28	18	<0.1											
DQ.F03.S20	White	0.1	19	8.9	5.6	10	26	15	16	<0.1											
Collagen	Mean data	84	16	3.0	1.8	3.7	47	17	12.4												
Whole egg	Mean data	46	22	17	13	22	15	11	0.0												
Microbe	Cave 85	13	22	14	16	17	23	7	0.3	16	0	0	0.6	1.2	16	0.2	22	59			
Gum tragacanth	Iranian Kurdistan	68	3.2	3.7	0	50	13	0	0	0	3.7	0	50	13	0	0	17	13			
Mucilage	Cucumber	52	0.6	0	1	3	2	0.3	36	52	6										
Apricot gum	Mogao	70	1.0	0	0	40	7.0	4.0	0	2.0	46										
Gum arabic	England	59	22	0.1	0	36	0	0	0	0.2	41										
DP98PE12	Shiny brown	8.4	1.5	2.9	0.6	20	9.5	2.4	19	25	19										
PLATXQ98P2	Amber "resin"	4.1	7.3	4.5	2.7	9.7	6.9	4.5	1.5	45	18										
NP98P9	Red	2.2	0	0.1	0	3.3	44	13	3.5	33	2.5										
NQ01PE12	White ground	0.75	0	0	0	21	0	0	0	79	0										
DP98PE13	Tan	0.23	1.2	0	0.6	6.7	3.7	1.8	47	31	7.9										
JXNB98PE11	White & earth	0.23	0	0	0	2.2	2.2	0	32	63	0.7										
NPOOPE4	Red, ground & earth	0.21	0.6	0.5	0	3.6	3.7	2.1	25	59	5.4										
PLATXQ98P2	Red & ground	0.21	16	1.2	1.5	15	7.3	4.7	10	22	22										
XQ98PE2	Red	0.20	3.7	0	0	8.9	16	4.4	21	40	6.7										
NQ98P4	Red & ground	0.17	2.4	0	0	7.2	78	7.2	0	0	4.8										
DQ98PE3	Tan & earth	0.12	0.4	0.1	0	8.2	5.0	0	7.3	75	3.4										

was decided to avoid overinterpreting the test results for the remaining samples and wait until more research is carried out. The results of this study make it abundantly clear that this area is ripe for future exploration.

Discovery of organic colorants in the wall paintings was one of the most surprising findings of the cave 85 project. Their presence in the wall paintings influenced many aspects of the project, including analysis of the artists' materials and painting technique, conservation treatments, and assessing safe levels of illumination. Consequently, a research project has been initiated at the GCI, in collaboration with the Dunhuang Academy, to study organic colorants in Chinese wall paintings (see Grzywacz et al., this volume).

Pigment Alteration

Another interesting aspect of the analytical research was investigating the appearance and condition of the wall paintings, and two examples will illustrate some of the more important results. For instance, a paint cross section from a bluish green robe of a figure on the east slope was studied by light microscopy and ESEM-EDX (figs. 3a, b). The cross section shows greenish particles in the paint layer, many of which have blue centers. Elemental maps of copper and chlorine show a progressive inward transformation of the blue azurite particles to the green pigment atacamite. The conver-

sion of azurite to atacamite has been shown to proceed when environmental conditions are favorable and chloride ion in wall paintings is abundant (Dei et al. 1998; Kerber, Koller, and Mairinger 1972; Naumova and Pisareva 1994).

It was discovered that some colors in cave 85 exhibit a blanched appearance that is related to the transformation of arsenic sulfide pigments. Orpiment, a yellow mineral, As_2S_3 , has been identified in wall paintings at Datong (Piqué 1997) and Mogao (Guo Hong 1997). Orpiment may, under certain circumstances, lose its color to form white arsenic trioxide; exposure to light, ozone, and heat are all known to affect the rate and extent of the reaction (FitzHugh 1997; Walker 1999). This explains why orpiment crystals in mineralogical displays occasionally are covered with a thin, powdery, white layer. Realgar, a red mineral, As_4S_4 , has seldom been identified in Chinese wall paintings. Realgar is also light sensitive and is less permanent than orpiment, transforming into pararealgar, orpiment, or arsenic trioxide (FitzHugh 1997).

In addition to light exposure, microorganisms have the potential to transform arsenic pigments. It is known that microorganisms are capable of altering pigments in wall paintings (Petushkova and Lyalikova 1986) and, moreover, that some microbes are capable of thriving even in the presence of highly toxic arsenic minerals. For instance, several bacteria, including *Pseudomonas arsenitoxidans*, can convert orpiment and realgar to arsenite and arsenate. In aerobic

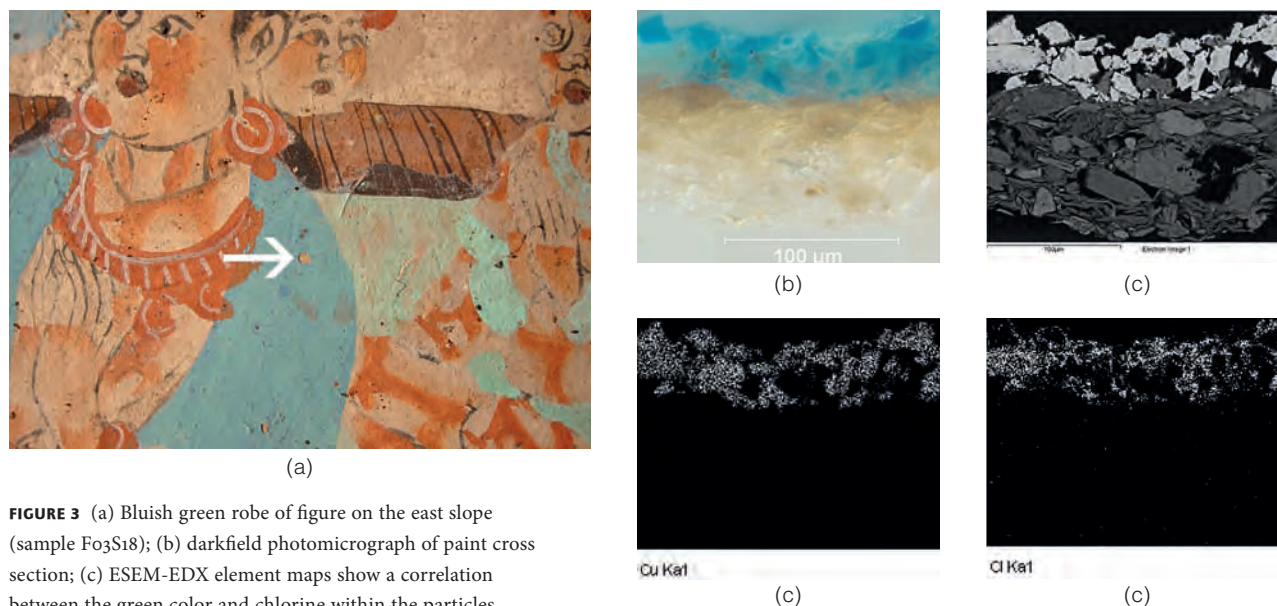

FIGURE 3 (a) Bluish green robe of figure on the east slope (sample Fo3Si8); (b) darkfield photomicrograph of paint cross section; (c) ESEM-EDX element maps show a correlation between the green color and chlorine within the particles, which indicates a progressive inward transformation of blue azurite into green atacamite.



FIGURE 4 Figure on the east wall with a blached flesh tone (sample F03S20); and darkfield photomicrograph of a paint cross section (inset).

conditions, some fungi, such as *Scopulariopsis brevicaulis* and *Penicillium* sp., are capable of biomethylation of arsenic oxyanions to form trimethyl- or dimethylarsine (Kurek 2002). *Scopulariopsis* colonies, which grow moderately rapidly and mature within five days, are granular to powdery in texture; the surface color is white initially, becoming light brown or buff tan over time (Sutton, Fothergill, and Rinaldi 1998).

From the study of the artists' materials in cave 85, unaltered orpiment was identified in only one area: directly beneath a red lead layer from a figure on the east slope (sample 85DP98PE12). The red lead layer on the figure would have protected the orpiment both from light exposure and from microbial activity. More typical was the detection of arsenic in several painted areas that exhibited a blached whitish appearance, such as in the flesh tone of a figure on the east wall (fig. 4). In cross section, white globular clumps on the surface of the painting (inset) were found to be rich in arsenic but lacking in sulfur. Microscopic examination revealed that the surface was covered with white microbial hyphae that stained positively using methylene blue. In none of the blached paints was XRD capable of identifying the white, arsenic-containing substance. GC-MS analyses of these same areas showed a reduced content of binding medium.

Although it should be possible to identify the microorganisms present in the white efflorescence on the blached paints in cave 85 by DNA analysis, the quantity of available material at the time was extremely limited. Instead, the DNA of a much larger white deposit present on several colors of the wall paintings in cave 98 (fig. 5), another large late Tang dynasty cave similar to cave 85, was analyzed using a nested polymerase chain reaction approach. This technique improves the detection of DNA by double amplification using two sets of primers and sequencing the bands of separated DNA. The deposit, albeit difficult to analyze because of age and limited amount of residual DNA, was shown to consist of a mixed, largely unidentified, microbial colony. Interestingly, many of the identifiable bacteria species were found to be capable of oxidizing sulfides, sulfur, and thiosulfates; one such species was *Sulfurimonas* (Mazurek 2007).

To summarize the findings, the example of the blached flesh tone layer provides evidence for transformation of arsenic sulfide pigment into an obscuring whitish tan layer. During this process, arsenic-tolerant microbes may have metabolized the paint media, greatly reducing its concentration. The arsenic sulfide pigment has converted, either by the action of microbes or by exposure to light, into a white compound lacking sulfur. Considering that the compound could not be identified by XRD, this finding lends some support to

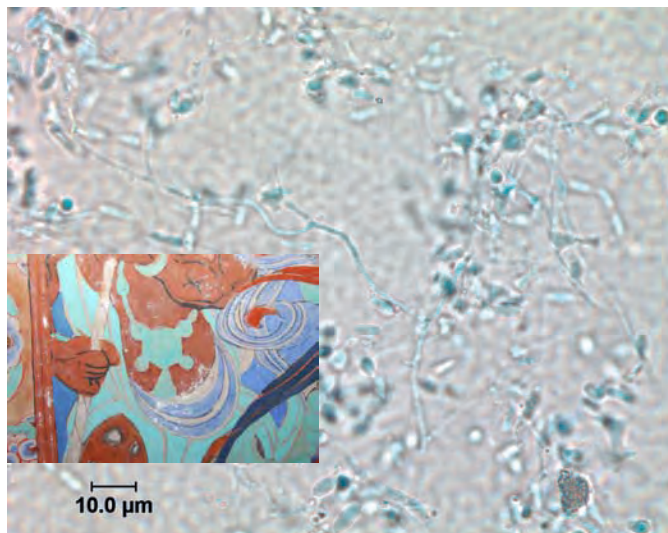

FIGURE 5 Photomicrograph of white microbial deposit (after staining with methylene blue) that is present on the wall paintings in cave 98.

Table 2 Summary of Salt Distribution Data in Cave 85 Based on Microcore Salt Survey

Summary of Ion Chromatography Results for Plaster Microcore Samples								
	Meq of Ion (normalized)/100 g Plaster							
Sample Location	Anion to Cation Ratio	Cl	NO ₃	SO ₄	Na	K	Mg	Ca
Cave 85, eastern end, above 2 m	0.6 ± 0.1	12 ± 8	1.3 ± 0.7	24 ± 9	40 ± 11	2.5 ± 0.6	2.6 ± 1.5	18 ± 8
Cave 85, western end, above 2 m	0.8 ± 0.1	27 ± 6	1.1 ± 0.2	16 ± 4	46 ± 3	1.1 ± 0.3	0.7 ± 0.3	7.3 ± 3.5
Cave 85, eastern end, below 2 m	0.9 ± 0.02	38 ± 4	5.4 ± 2.0	4.3 ± 1.6	17 ± 13	1.0 ± 0.2	16 ± 6	18 ± 6
Cave 85, western end, below 2 m	0.9 ± 0.1	32 ± 3	1.1 ± 0.3	14 ± 1	47 ± 1	0.9 ± 0.2	0.5 ± 0.2	4.3 ± 1.4
Conglomerate from storage area	0.8	23	1.2	19	43	0.3	2.9	10
Cave 61, eastern end	0.8 ± 0.1	16 ± 5	5.8 ± 1.2	21 ± 9	31 ± 12	3.1 ± 0.9	5.8 ± 0.7	17 ± 9
Cave 61, western end	0.8 ± 0.1	18 ± 6	3.1 ± 1.4	22 ± 9	31 ± 8	3.7 ± 2.0	6.6 ± 3.3	16 ± 5
Cave 98, eastern end	0.8 ± 0.2	19 ± 11	1.2 ± 0.5	23 ± 9	36 ± 12	1.9 ± 1.3	3.9 ± 2.9	15 ± 10
Cave 98, western end	0.9 ± 0.1	22 ± 7	1.0 ± 0.7	23 ± 6	35 ± 6	1.2 ± 0.5	2.1 ± 1.3	15 ± 5
	Weight Percent of Ion in Plaster							
Sample Location	Weight %	Cl	NO ₃	SO ₄	Na	K	Mg	Ca
Cave 85, eastern end, above 2 m	0.6 ± 0.2	0.1 ± 0.1	0.02 ± 0.01	0.2 ± 0.1	0.2 ± 0.1	0.02 ± 0.004	0.006 ± 0.002	0.07 ± 0.03
Cave 85, western end, above 2 m	2.3 ± 1.0	0.8 ± 0.4	0.05 ± 0.03	0.5 ± 0.2	0.8 ± 0.3	0.03 ± 0.01	0.006 ± 0.003	0.09 ± 0.05
Cave 85, eastern end, below 2 m	2.8 ± 0.4	1.3 ± 0.3	0.32 ± 0.10	0.2 ± 0.1	0.4 ± 0.3	0.04 ± 0.001	0.19 ± 0.08	0.36 ± 0.15
Cave 85, western end, below 2 m	3.5 ± 1.3	1.3 ± 0.6	0.07 ± 0.02	0.8 ± 0.3	1.2 ± 0.4	0.04 ± 0.01	0.006 ± 0.001	0.09 ± 0.03
Cave 61, eastern end	0.9 ± 0.2	0.2 ± 0.01	0.1 ± 0.01	0.3 ± 0.2	0.2 ± 0.03	0.03 ± 0.002	0.02 ± 0.01	0.10 ± 0.08
Cave 61, western end	1.2 ± 1.3	0.2 ± 0.1	0.05 ± 0.01	0.5 ± 0.7	0.2 ± 0.3	0.04 ± 0.01	0.02 ± 0.02	0.12 ± 0.11
Cave 98, eastern end	2.3 ± 2.2	0.7 ± 1.0	0.04 ± 0.02	0.7 ± 0.5	0.6 ± 0.8	0.04 ± 0.01	0.02 ± 0.01	0.16 ± 0.09
Cave 98, western end	2.8 ± 0.8	0.7 ± 0.4	0.05 ± 0.02	1.0 ± 0.4	0.7 ± 0.2	0.04 ± 0.01	0.02 ± 0.01	0.26 ± 0.12

the microbial-induced transformation mechanism because arsenic trioxide is known to form from orpiment by light exposure. The sulfide counter-ion from the arsenic pigment has likely dissipated as hydrogen sulfide, a conclusion that is consistent with either mechanism. Although the microorganism growing on the blanched arsenic-containing paint has yet to be identified and the precise role of light in the transformation process is uncertain, it is clear that microbial activity must be considered in searching for explanations of the blanching phenomenon.

Hygroscopic Salts

Hygroscopic salts have caused great damage to the wall paintings, and therefore much analytical work was conducted in order to study their composition and distribution in the conglomerate rock, plaster layer, and paintings using ion chromatography (IC), ion-selective electrodes, and ESEM-EDX. A summary of IC data for the microcore plaster samples that were obtained from forty-seven sample locations is presented in table 2. The IC method employed for the tests detected most of the common cations and anions

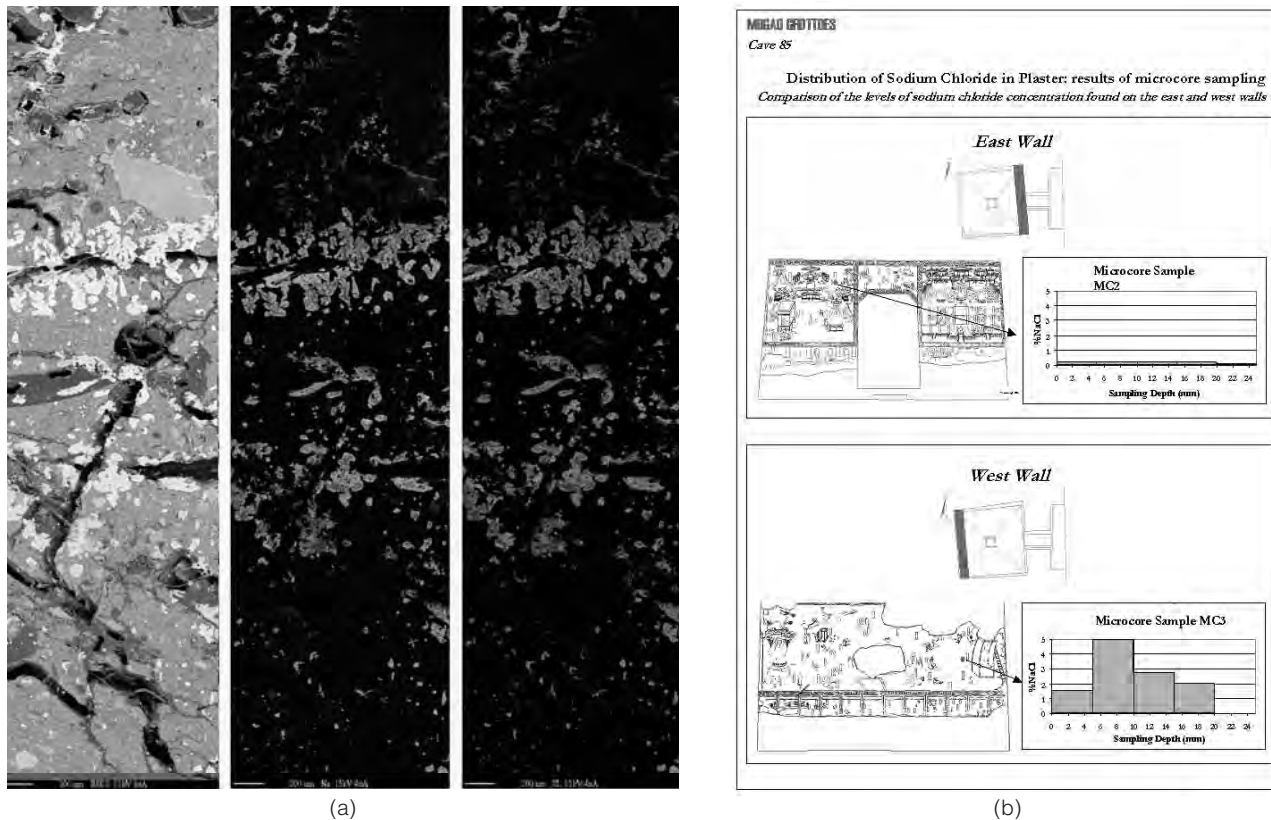

FIGURE 6 (a) ESEM-EDX element maps for a cross section of plaster from the west end of the north wall (sample 85BQ99E3); (b) salt profiles for plaster microcore samples from the east and west walls.

in hygroscopic salt mixtures. However, independent tests of salts in core samples of the conglomerate rock from cave 98 confirmed the presence of small amounts of bicarbonate and carbonate within the conglomerate (Lin 2005). These two anions were not detected by the IC method; hence their absence from the data set in table 2 may partly explain the deficit in the anion to cation ratio for the cave 85 microcore samples.

The pH of the hygroscopic salts may affect the deterioration rate of organic materials such as the paint media and plant fibers, as well as the discoloration of mineral and organic pigments. Sheng Fenling, Li Zuixiong, and Fan Zaixuan (1993) reported a pH of 7.6 for the Daquan River, which is one source of salt in the caves. In a broad study of a core sample of conglomerate rock from cave 98, Lin (2005) reports a pH of 8.64 for the salt extracted from the conglomerate. According to test strips, the mean pH of the cave 85 plaster microcores was approximately 7, although the accuracy of test strip measurements is certainly less than for readings obtained by a pH

electrode. In summary, the salts in and around cave 85 tend to be slightly alkaline.

It is clear from table 2 that salts are substantially enriched in the plaster at the west end of the cave, which is consistent with the greater extent of observed damage there, compared to that at the east end of the cave. This trend is also observed in cave 98, which exhibits the same extent and type of damage as cave 85, whereas in cave 61 the salt content is substantially lower, as is the corresponding degree of damage.

Although many anions and cations are present in the hygroscopic salt mixtures listed in table 2, sodium chloride is by far the predominant damaging salt. Crystalline deposits of nearly pure sodium chloride were discovered on the inner face of a plaster fragment that had fallen from the western slope, and sodium chloride crystals have formed on the paintings. In ESEM-EDX analysis of a plaster cross section (fig. 6), sodium chloride is shown to have accumulated at cracks and fissures in the plaster, whereas sulfur (from sulfate) is notably

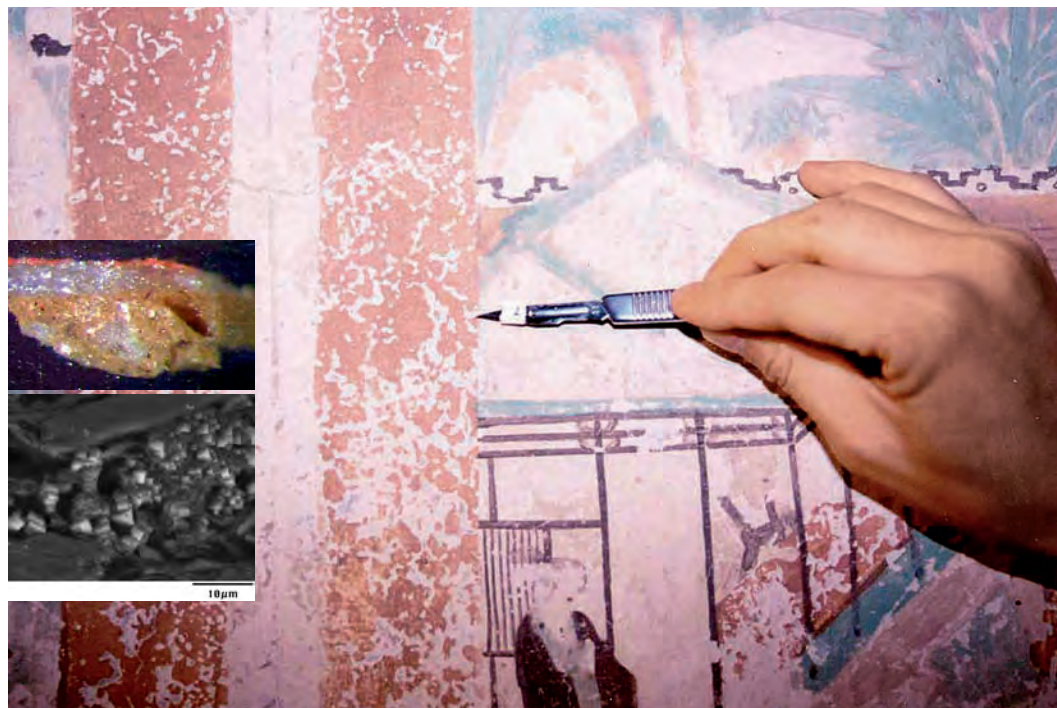

FIGURE 7 Punctate eruption of sodium chloride crystals between the red paint and ground layers in sample 85NQ98PE2. (a) Darkfield photomicrograph of paint cross section; (b) ESEM enlargement showing cubic crystals of sodium chloride.

absent. Moreover, bands of sodium chloride are visible in the elemental maps just slightly beneath the painted surface, showing that the salt is more concentrated in that region. This is consistent with the plaster microcore data.

The appearance of small, rounded holes in the paint layer is a common phenomenon in cave 85. Defined in this project as “punctate eruption,” it is most obvious on dark red stripes and bands (fig. 7), although to a lesser extent it affects other colors, including the ground. In order to understand more fully the cause of this phenomenon, ESEM was used to examine a cross-section sample taken from a dark red stripe on the south wall. In this sample, crystals of sodium chloride were observed between the red paint layer and the ground. As sodium chloride crystals form between the paint and ground layers, eventually they break through the paint and leave small losses.

Gypsum deposits have also been reported on the wall paintings and plaster layers in certain caves at Mogao (Kuchitsu and Duan Xiuye 1997). These deposits were attributed to the reaction between the soluble sulfate from the hygroscopic salts and calcium-rich minerals present in the paint and ground layers. Gypsum was detected in cave 85, primarily in association with the red organic colorants, although it is not clear if gypsum was intention-

ally used in the process of precipitating the dyestuffs into the form of pigments.

Conclusion

Several valuable lessons can be learned from the experiences of the analytical research team working on the cave 85 project. One of the most important aspects of the process was the careful examination of the wall paintings for the purpose of selecting representative samples; sturdy scaffolding and adequate task lighting were essential for eventual success due to the nonuniform condition of the paintings throughout the cave. The examination, carried out by experienced wall painting conservators, often involved discussions with conservation scientists. Without truly representative samples accompanied by thorough documentation of the sample location, it would have been impossible to obtain accurate results, even with the finest laboratory equipment.

The dictum “Do as much as necessary but as little as possible” certainly pertains to analytical investigations of wall paintings. It is hard to imagine exhausting the research possibilities that are presented by the masterpieces of Tang dynasty wall painting in cave 85, let alone those afforded by every painted cave temple in the Mogao Grottoes.

Acknowledgments

The authors express their gratitude for the leadership of Neville Agnew, who inspired the project team to overcome challenges. We also wish to acknowledge the efforts of the conservation team, valued colleagues who through hard work made many discoveries throughout the project and who contributed greatly to this study; Francesca Piqué, Lisa Shekede, and Lorinda Wong merit recognition for their analytical expertise and willingness to share their knowledge and experience. At the GCI, we wish to thank Giacomo Chiari, chief scientist, and Alberto de Tagle, former head of Science, for their support; Shin Maekawa, senior scientist and leader of the Environmental Monitoring Team, for many discussions; Herant Khanjian for his FTIR expertise; and Eric Doehne for discussions about hygroscopic salts. At the Dunhuang Academy, we wish to thank Li Zuixiong and Wang Xudong for their support; and Chen Gangquan, Yu Zongren, Zhao Linyi, and Guo Hong for their excellent analytical work, dedication, and friendship.

Notes

- 1 The laboratory facilities at the Dunhuang Academy house X-ray diffraction (XRD) for identification of mineral pigments, and Fourier transform infrared spectrometry (FTIR) for analysis of minerals, natural organic materials, and synthetic polymers. Over the course of the project, a program of staff exchanges gave several Dunhuang Academy scientists opportunities to conduct research on specialized equipment at the GCI. Their studies featured environmental scanning electron microscopy with energy-dispersive X-ray spectrometry (ESEM-EDX) for mapping elemental distributions within paint cross sections, identification of animal glue and plant gum binding media using GC-MS, analysis of organic colorants using high-performance liquid chromatography/photodiode array-mass spectrometry (LC-PDA-MS), and soluble salt analysis using ion chromatography (IC). In addition, GCI scientists conducted advanced workshops at the Dunhuang Academy on the use of polarized light microscopy (PLM) for identifying mineral pigments in dispersions of paint particles, preparation and examination of paint cross sections for revealing painting technique, and use of ion-selective electrodes and test strips for salt analysis.

References

- Austin, G. S. 1998. Analytical report for the Getty Conservation Institute. New Mexico Bureau of Mines and Mineral Resources, Socorro, NM.
- Birstein, V. J. 1975. On the technology of central Asian wall paintings: The problem of binding media. *Studies in Conservation* 20 (1): 8–19.
- Bisbing, R. E. 2006. Analytical report from McCrone Associates, Inc.
- Columbini, M. P., R. Fuoco, A. Giacomelli, and B. Muscatello. 1998. Characterization of proteinaceous binders in wall painting samples by microwave-assisted acid hydrolysis and GC-MS determination of amino acids. *Studies in Conservation* 43 (1): 33–41.
- Dei, L., A. Ahle, P. Baglioni, D. Dini, and E. Ferroni. 1998. Green degradation products of azurite in wall paintings: Identification and conservation treatment. *Studies in Conservation* 43 (2): 80–88.
- FitzHugh, E. W. 1997. Orpiment and realgar. *Artists' Pigments: A Handbook of Their History and Characteristics*, vol. 3, ed. E. W. FitzHugh, 47–79. Oxford: Oxford University Press; Washington, DC: National Gallery of Art.
- Guo Hong. 1997. Dunhuang Academy Conservation Institute internal report on mineral pigment identification.
- Kerber, G., M. Koller, and F. Mairinger. 1972. Studies of blue-green alterations in Austrian medieval wall paintings. In *ICOM Committee for Conservation, Madrid, 1972: Preprints*. Paris: International Council of Museums.
- Kuchitsu, N., and Duan Xiuye. 1997. Geological environment of the Mogao Grottoes at Dunhuang. In *Conservation of Ancient Sites on the Silk Road: Proceedings of an International Conference on the Conservation of Grotto Sites*, ed. N. Agnew, 244–48. Los Angeles: Getty Conservation Institute.
- Kurek, E. 2002. Microbial mobilization of metals from soil minerals under aerobic conditions. In *Interactions between Soil Particles and Microorganisms: Impact on the Terrestrial Ecosystem*, ed. P. M. Huang, J.-M. Bollag, and N. Senesi, 189–226. IUPAC Series on Analytical and Physical Chemistry of Environmental Systems, vol. 8. New York: Wiley.
- Li Shi. 1995. [Quantitative analysis on the binding media in the Dunhuang wall paintings]. *Dunhuang Studies* 3: 29–46.
- Lin, P. M. 2005. English translation of analytical report from the Lanzhou Coal Mining Research Institute, dated September 13.
- Mazurek, J. 2007. Getty Conservation Institute internal report on work by Dora Ogles, Microbial Insights, May 21.
- Naumova, M. M., and S. A. Pisareva. 1994. A note on the use of blue and green copper compounds in paintings. *Studies in Conservation* 39 (4): 277–83.
- Petushkova, J. P., and N. N. Lyalikova. 1986. Microbiological degradation of lead-containing pigments in mural paintings. *Studies in Conservation* 31 (2): 65–69.
- Piqué, F. 1997. Scientific examination of the sculptural polychromy of cave 6 at Yungang. In *Conservation of Ancient Sites on the*

- Silk Road: Proceedings of an International Conference on the Conservation of Grotto Sites*, ed. N. Agnew, 348–61. Los Angeles: Getty Conservation Institute.
- Schilling, M. 2005. Paint media analysis. In *Scientific Examination of Art: Modern Techniques in Conservation and Analysis*, ed. M. Schilling and T. Learner, 186–205. Washington, DC: National Academies Press.
- Schilling, M. R., and H. P. Khanjian. 1996a. Gas chromatographic analysis of amino acids as ethyl chloroformate derivatives. II. Effects of pigments and accelerated aging on the identification of proteinaceous binding media. *Journal of the American Institute of Conservation* 35 (2): 123–44.
- . 1996b. Gas chromatographic analysis of amino acids as ethyl chloroformate derivatives. III. Identification of proteinaceous binding media by interpretation of amino acid composition data. In *11th Triennial Meeting, Edinburgh, Scotland, 1–6 September 1996: Preprints*, ed. J. Bridgland, 211–19. London: James and James.
- Sheng Fenling, Li Zuixiong, and Fan Zaixuan. 1993 [New developments in the research of color changes in red lead, vermilion and hematite]. In *Dunhuang yan jiu wen ji*, Dunhuang yan jiu yuan (China), 1:258–75. Lanzhou: Gansu min zu chu ban she.
- Sutton, D. A., A. W. Fothergill, and M. G. Rinaldi, eds. 1998. *Guide to Clinically Significant Fungi*. 1st ed. Baltimore: Williams & Wilkins.
- Wainwright, I. N. M., E. A. Moffatt, P. J. Sirois, and G. S. Young. 1997. Analysis of wall painting fragments from the Mogao and the Bingling Temple grottoes. In *Conservation of Ancient Sites on the Silk Road: Proceedings of an International Conference on the Conservation of Grotto Sites*, ed. N. Agnew, 334–40. Los Angeles: Getty Conservation Institute.
- Walker, M. 1999. Arsenic and old paint. *New Scientist* 2188: 20.
- Wang Junhu, Song J. Li, and M. Schilling. 1995. [On the characteristics of pigments and the distribution of colors during the Sixteen Kingdoms at the Mogao Grottoes, Dunhuang]. *Dunhuang Research* 3: 87–99.
- Xu Weiye, Zhou Guoxin, and Li Yunhe. 1983. A report of an X-ray analysis of the inorganic pigments in the murals and sculptures of Mogao Grottoes. *Dunhuang Research* 3: 187–97.
- Yu Feian, J. Silbergeld, and A. McNair. 1988. *Chinese Painting Colors: Studies of Their Preparation and Application in Traditional and Modern Times*. Seattle: University of Washington Press; Hong Kong: Hong Kong University Press.

Asian Organic Colorants: A Collaborative Research Project

Cecily M. Grzywacz, Jan Wouters, Su Bomin, and Fan Yuquan

Abstract: *The presence of organic colorants has been reported on the wall paintings at Mogao Grottoes by the cave 85 project team. To address the challenges of identifying these organic colorants, a collaborative multiyear project was begun in 2006 between the Getty Conservation Institute, Jan Wouters, Belgium, and the Dunhuang Academy. Determining specific organic colorants that could have been used in China is a challenge because the biological sources used to produce the dyes and pigments frequently are unique to the geographic region. This paper describes the Asian organic colorants project and the experimental design used to develop a systematic strategy for the analysis of Asian organic colorants. The Mogao Grottoes wall painting colorants will ultimately be determined using this strategy.*

The analytical research conducted by the Getty Conservation Institute (GCI) at the Mogao Grottoes generated a wealth of information on the mineral pigments and binding media used in these caves, especially cave 85 (see Schilling et al., this volume). Shekede and other conservators working at the site have also reported the use of organic colorants and washes as a final layer in the caves (see Shekede et al., this volume). As the use of organic colorants is recognized by conservators throughout Asian wall paintings, there is an increasing need to determine which biological sources were used to prepare them. This will provide crucial information for the preservation of the wall paintings and lead to a better understanding of painting techniques and the ability to decipher the original painted image (Yamauchi, Taniguchi, and Uno 2007: 120). Determining specific organic colorants that could have been used in China requires identification of the biological sources used to produce the dyes

and pigments, which most likely were unique to the geographic region.

To address these questions a collaborative research project was initiated between the GCI, consultant Jan Wouters, and the Dunhuang Academy. The Asian organic colorants (AOC) project is a systematic, multiyear scientific research effort to develop a strategy for the analysis of traditional Chinese organic colorants used as textile dyes and organic pigments in wall paintings, in China and beyond. Detection and identification of these colorants present a challenge not only because many of the biological sources used to create them have not been well studied but also because, in the case of paints prepared with organic pigments, the concentrations of the colorants are relatively low compared to those of inorganic pigments and binding media. The AOC project is expected to generate knowledge that will resolve some remaining problems with identification of natural organic colorants in Asia, reported in former studies (Wouters 1994, 1997, 1998).

The project has five components:

1. Thorough literature search on Chinese biological sources, painting techniques, and analysis methods.
2. Acquisition of selected plant and insect materials to prepare reference samples.
3. Making paints of the organic pigments and applying them on painted plaster coupons that replicate the stratigraphy of the wall paintings at the Mogao Grottoes.
4. Analysis of reference samples and the coupons to determine their diagnostic value and development

of an analytical strategy to identify Asian organic colorants.

5. Application of this analytical strategy to historical samples from the Mogao Grottoes.

Literature Search

A literature search was mandatory to determine which biological sources may have been used on the Mogao Grottoes wall paintings and polychrome sculpture (Grzywacz et al. 2008). Searches of Art & Archaeology Technical Abstracts (AATA), Bibliographic Conservation Information Network, Scopus, SciFinder, and World of Science resulted in nearly 900 abstracts. These were screened, and more than 500 relevant papers and books were read. One hundred fifty different biological sources were found, often as botanically identified genus or species or sometimes using common nomenclature. Citations from independent references for biological sources were counted to identify the most frequently cited ones. Thirty source groups were selected. Some groups refer to a species, even when relevant citations in the literature did not; for example, citations of safflower undoubtedly refer to *Carthamus tinctorius* L. and were classified and counted as such. However, confusion arose with the species identifications of madder (*Rubiaceae* family) and plants producing indigoid dyes (*Indigofera*, *Isatis*, *Strobilanthes*, *Polygonum* genuses). For those groups, species were selected that were most suggestive for the region, based on botanical encyclopedic references (Bensky et al. 2004; Cardon 2007; Fèvre and Métaillé 2005; Huxley, Griffiths, and Levy 1999; Jiaju Zhou et al. 2003; Mabberley 1993; Wu Zhengyi, Raven, and Hong Deyuan 2008) and on a 2006 interview with Jingwu Wang, botanist, Beijing University.

Currently, the AOC bibliography contains more than 250 articles, books, and online resources. In addition to biological sources, data on recipes, painting techniques, and historical context were collected. A list of key literature on analysis and identification of Asian organic colorants has also been compiled. It will be published as an AATA bibliography, available on the GCI Web site.

Biological Sources and Acquisitions

An initial thorough literature search conducted on biological sources used to produce organic colorants revealed the most likely ones for the production of organic colorants used in Asia, specifically China and hence at the Mogao Grottoes.



FIGURE 1 Shopping for biological sources at a pharmacy in Dunhuang, Gansu province, China.

A total of 108 different biological sources were identified, but based on the frequency of independent citations, 36 biological sources, belonging to 30 groups, were selected for study. Table 1 is a complete list of the selected groups of AOC biological sources.

Plants and resins identified for paint production and analysis were purchased at pharmacies in Dunhuang and Beijing and at Chinese pharmacies in the Los Angeles area (fig. 1). Items not available at pharmacies were acquired from botanical gardens in the United States and China. Some sources were purchased at the chemical market in Old Delhi, India.

Preparations

Bulk reference samples were prepared from each biological source, using historical recipes when available (fig. 2). When



FIGURE 2 Series of AOC reference samples prepared from *Gardenia augusta* L. From left to right: dyed wool, dyed silk, cake and pigment.

Table 1 Biological Sources Used to Produce Asian Organic Colorants in Order of Number of Citations

Dye Group; Prominent Color	Citations	Common Name of Species	Chinese Name	Pinyin	Genus	Species and Author [synonym(s)]
Indigoid; blue	55	conehead	板蓝	ban lan	<i>Baphicacanthus</i>	<i>cusia</i> (Nees) Bremekamp [<i>Strobilanthes cusia</i> (Nees) O. Kuntze, Ma Lan Gen 马蓝 = <i>Strobilanthes flaccidifolius</i> Nees]
		wild indigo, West Indian indigo	野青树	ye qing shu	<i>Indigofera</i>	<i>suffruticosa</i> Mill
		dyer's indigo	木蓝	mu lan		<i>tinctoria</i> L.
		indigo woad, Chinese indigo	大青叶	da qing	<i>Isatis</i>	<i>indigotica</i> Fort.
		dyer's woad	菘蓝	song lan		<i>tinctoria</i> L.
Chinese indigo	蓼蓝	liao lan	<i>Polygonum</i>	<i>tinctorium</i> Ait. [<i>P. tinctorium</i> Lour.; <i>Persicaria tinctoria</i> (Ait.) Spach]		
Madder; red	27	Japanese madder	日本茜草	ri ben qian cao	<i>Rubia</i>	<i>akane</i> Nakai
		Indian madder, Chinese madder, munjeet	茜草炭 or 茜草	qian cao gen or qian cao		<i>cordifolia</i> L. [<i>R. munjista</i> Roxb.]
		European madder; munjeet	杨茜草	yang qian cao		<i>tinctorum</i> L.
Safflower; salmon red	23	safflower	红花	hong hua	<i>Carthamus</i>	<i>tinctorius</i> L.
Redwood; red	18	redwood; brazilwood	苏木	su mu	<i>Caesalpinia</i>	<i>sappan</i> L.
Shikon; purple	17	red root Gromwell	紫草	zi cao	<i>Lithospermum</i>	<i>erythrorhizon</i> Sieb. & Zucc.
		pearl Gromwell	小花紫草	xiao hua zi cao		<i>officinale</i> L.
Japanese pa- goda tree; yellow	17	Chinese yellow berries	槐花	huai shu	<i>Sophora</i>	<i>japonica</i> L. [<i>Styphnolobium</i> <i>japonicum</i> (L.) Schott]
Gardenia; yellow	14	Cape jasmine	梔子	zhi zi	<i>Gardenia</i>	<i>jasminoides</i> Ellis [<i>G. augusta</i> (L.) Merrill; <i>G. florida</i> L.]
Amur cork tree; yellow	13	amur cork tree	黄柏	huang bai	<i>Phellodendron</i>	<i>amurense</i> Ruprecht
Buckthorn; yellow	13	common buckthorn	药鼠李	yao shu li	<i>Rhamnus</i>	<i>catharticus</i> L.
			鼠李	shu li		<i>chlorophorus</i> Decne. ex Hemsl.
		Davurian buckthorn	鼠李	shu li		<i>davurica</i> Pallas
		Chinese buckthorn	冻绿	dong lu		<i>utilis</i> J. Descaisne
Gamboge; yellow	12	rattan yellow	藤黄树	teng huang shu	<i>Garcinia</i>	<i>hanburyi</i> Hook. f.
			藤黄	teng huang ke		<i>morella</i> Gaertn.
Turmeric; yellow	9	common turmeric	姜黄	jiang huang	<i>Curcuma</i>	<i>longa</i> L. [<i>C. domestica</i> Valetton]
			郁金	yu jin		<i>aromatica</i> Salisbury
			温郁金	wen yu jin		<i>wenyulin</i> YH Chen & C Ling

Table 1 (cont.)

Dye Group; Prominent Color	Citations	Common Name of Species	Chinese Name	Pinyin	Genus	Species and Author [synonym(s)]
Lac; red	9	Indian lac	紫胶虫	zi jiao chong	<i>Kerria</i>	<i>lacca</i> Kerr [<i>Laccifer lacca</i> Cockerell]
Young fustic; yellow	7	young fustic	黄栌	huang lu	<i>Cotinus</i>	<i>coggygia</i> Scopoli [<i>Rhus cotinus</i> L.]
			灰毛黄栌	hui mao huang		<i>coggygia</i> var. <i>cinerea</i> Engler [<i>C. cinerea</i> (Engler) FA Barkley]
Silver grass; yellow	7	Chinese silver grass	芒萁	mang jing	<i>Miscanthus</i>	<i>sinensis</i> Andersson
		Dyeing silver grass	青茅	qing mao		<i>tinctorius</i> (Sieb. ex Steud.) Hack.
Barberry; yellow	5	Japanese barberry	日本小檗	ri ben xiao bo	<i>Berberis</i>	<i>thunbergii</i> DC
		S. China Mahonia; Japanese Mahonia	台湾十大功劳	tai wan shi da gong lao	<i>Mahonia</i>	<i>japonica</i> (Thunb.) DC [<i>Berberis japonica</i> (Thunb.) R. Br.]
Joint grass; yellow	4	hairy jointgrass; small carpgrass; kobuna-gusa (Jap.)	萁草	jin cao	<i>Arthraxon</i>	<i>hispidus</i> (Thunb.) Makino
			hua nan gong lao mu			
Walnut; brown	4	walnut	胡桃	hu tao	<i>Juglans</i>	<i>regia</i> L.
Sandalwood; red	4	red sandalwood	紫檀		<i>Pterocarpus</i>	<i>santalinus</i> L. f.
Oak; beige	4	sawtooth oak	麻栎	ma li	<i>Quercus</i>	<i>acutissima</i> Carruthers
Rhubarb; red	4	rhubarb	药用大黄 or 大黄	yao yong da huang or da huang	<i>Rheum</i>	<i>officinale</i> Baillon
			掌叶大黄	zhang ye da huang		<i>palmatum</i> L.
			鸡爪大黄	ji zhua da huang		<i>tanguticum</i> (Max. ex Regel) Max. ex Balfour
Tannin; gray to black	4	Chinese sumac	盐麸木	yan fu mu	<i>Rhus</i>	<i>semialata</i> Murray = <i>Rhus chinensis</i> Miller
Coptis; yellow	3	Chinese goldthread	黄连	huang lian	<i>Coptis</i>	<i>teeta</i> var. <i>chinensis</i> (Franch.) Finet & Gagnep. [<i>C. chinensis</i> var. <i>chinensis</i> ; <i>C. chinensis</i> Franch.]
			云南黄连	yun nan huang lian		<i>teeta</i> Wallich [<i>C. teetoides</i> CY Cheng]
		Japanese goldthread	胡黄连 日本 黄连	hu huang lian ri ben huang lian	<i>Neopicrorhiza</i>	<i>scrophulariiflora</i> (Pennell) DY Hong [<i>Picrorhiza scrophulariiflora</i> Pennell; <i>Coptis japonica</i> Makino]
Saffron; yellow	3	saffron	番红花	fan hong hua	<i>Crocus</i>	<i>sativus</i> L.
Larkspur; yellow	3	yellow larkspur			<i>Delphinium</i>	<i>semibarbatum</i> Bien. ex Boiss.
Bayberry; yellow	3	red bayberry, Chinese bayberry	杨梅	yang mei	<i>Myrica</i>	<i>rubra</i> Sieb. & Zucc.

Table 1 (cont.)

Dye Group; Prominent Color	Citations	Common Name of Species	Chinese Name	Pinyin	Genus	Species and Author [synonym(s)]
Dragon's blood; red	3	Dragon's blood	血竭	xue jie	<i>Daemonorops</i>	<i>draco</i> Blume
		Socotra dragon tree	血竭 of 珠红龙血树 (剑叶龙血树)	zhu hong long xue shu (jian ye long xue shu)	<i>Dracaena</i>	<i>cinnabari</i> Balf. f.
		Cambodia dragon tree	血竭 of 海南龙 血树	hai nan long xue shu		<i>cambodiana</i> Pierra ex Gagnepain
		sword-leaved dragontree	血竭 of 剑叶龙血树	jian ye long xue shu		<i>cochinchinensis</i> (Lour.) SC Chen
Bedstraw; red	3	Our Lady's bedstraw	篷子菜		<i>Galium</i>	<i>verum</i> L.
Four o'clocks; red	3	marvel of Peru; shower flower	紫茉莉	zi mo li	<i>Mirabilis</i>	<i>jalapa</i> L.
Wash; no color	1	pearlwort	根叶漆姑草	gen ye qi gu cao	<i>Sagina</i>	<i>maxima</i> A. Gray
Carbon black; black	ink	princess tree, tong tree	毛泡桐	mao pao tong	<i>Paulownia</i>	<i>tomentosa</i> (Thunb.) Steud.
		ink	膜	mo	Various sources of poorly specified origin	

these were unavailable, modern laboratory practice, based on aqueous extractions and fermentations only, were used to prepare the samples. Dyeing of wool and silk was performed with or without preliminary mordanting with alum, depending on the chemical nature of the dyes. Occasionally, dyed cotton or paper was prepared. Pigments were prepared on a hydrated aluminum oxide base. Paints were prepared by suspending pigments in a diluted animal glue or fruit tree gum medium or by concentrating the dye extract and adding glue. Cakes were prepared by drying and hence concentrating

the dye extract. All preparations are documented and reference samples cataloged in a database.

One hundred forty painted plaster coupons, 15 centimeters in diameter, replicating the stratigraphy of the Mogao wall paintings were prepared by the Dunhuang Academy using clay and other materials available at Mogao. Each coupon has a traditional ground layer applied to half of its surface, overlaid with seven stripes of common inorganic paints used in the grottoes (fig. 3a). Organic paints prepared with the reference pigments were applied on the painted plaster cou-

FIGURE 3 (a) Blank painted plaster coupon as received from the Dunhuang Academy. (b) Coupon with *Gardenia augusta* pigment paints in gum and animal glue applied.



(a)



(b)

pons (fig. 3b). The plaster, ground, inorganic paints, and lake pigments provide crucial combinations for evaluating an analytical scheme. From each biological source, four mock-ups are produced: two for investigating the best possible analytical procedure(s), one for accelerated aging at the GCI, and one that will be kept in the GCI reference collection for future research.

Analytical Strategy

The development of a strategy for the analysis of organic dyes on yarns and organic pigments in paint requires consideration of the following parameters: level of destructiveness to both the object and the sample, diagnostic value, sensitivity, and reproducibility. High-performance liquid chromatography/photodiode array-mass spectrometry (HPLC-PDA-MS) is routinely used for analysis of organic dyes and pigments present in artifacts produced in Europe and the Americas. Its use in an Asian, or, more specifically, Chinese, context cannot necessarily be extrapolated because the majority of biological sources identified in Chinese artifacts were different from those found in the European and American artifacts. HPLC-PDA-MS will probably remain the core analytical technique because of its high diagnostic value, sensitivity, and reproducibility. The method used by the GCI will be optimized for the analysis of Asian organic dyestuffs and pigments. It will result in a library of ultraviolet-visible (UV-Vis) spectra for color-contributing components and an ion trap electrospray ionization negative ion mode (ESI-NIM) and positive ion mode (ESI-PIM) mass spectral database of the same diagnostic components of organic colorants that includes both MS and MS-MS spectra.

Additional techniques will be investigated for their ability to identify important information not adequately detected through HPLC-PDA-MS and for their ability to be less destructive on the object and sample. The project will consider the following additional analytical techniques: in-situ UV-induced fluorescence imaging (Verri 2007), microspectrofluorimetry (Claro et al. 2008), Raman spectroscopy and surface enhanced Raman spectroscopy (SERS) (Leona, Stenger, and Ferloni 2006), direct temperature-resolved mass spectrometry, and 3D-UV-Vis fluorescence spectroscopy.

Historical Samples

Once the analytical strategy is verified, historical samples from wall paintings at the Mogao Grottoes will be analyzed

and studied. The strategy will also be applicable to Asian dyestuffs used in textiles and Asian organic pigments used in paintings. The results of this research project should have far-reaching ramifications for the study of the cultural heritage in China and throughout the region. (For more information, see www.getty.edu/conservation/science/asian/index.html.)

Acknowledgments

The authors would like to acknowledge the Wall Paintings at Mogao Grottoes project team and Sharon Cather, Lisa Shekede, and Lorinda Wong for guidance on wall painting techniques at Mogao. The authors are grateful to Valerie Greathouse, for her crucial assistance in identifying literature; Sylvana Barrett, for teaching scientists how to prepare paints from organic lake pigments; and Jennifer Porter, for preparing several AOC paints and expertly applying them on the wall painting coupons.

References

- Bensky, D., S. Clavey, E. Stöger, and A. Gamble. 2004. *Chinese Herbal Medicine: Materia Medica*. 3rd ed. Seattle: Eastland Press.
- Cardon, D. 2007. *Natural Dyes: Sources, Tradition, Technology, and Science*. London: Archetype.
- Claro, A., M. J. Melo, S. Schäfer, J. S. Seixas de Melo, F. Pina, K. J. van den Berg, and A. Burnstock. 2008. The use of microspectrofluorimetry for the characterization of lake pigments. *Talanta* 74 (4): 922–29.
- Fèvre, F., and G. Métaillié. 2005. *Dictionnaire Ricci des plantes de Chine: Chinois, français, latin, anglais = Lishi Zhongguo zhi wu ming cheng ci dian: Han, Fa, La, Ying*. Paris: Association Ricci; Cerf.
- Grzywacz, C. M., Su Bomin, Fan Yuquan, and J. Wouters. 2008. Development of identification strategies for Asian organic colorants on historic Chinese wall paintings. In *15th Triennial Conference, New Delhi, 22–26 September 2008: Preprints*, ed. J. Bridgland, 534–41. Paris: ICOM Committee for Conservation.
- Huxley, A. J., M. Griffiths, and M. Levy. 1999. *The New Royal Horticultural Society Dictionary of Gardening*. London: Macmillan Reference; New York: Grove's Dictionaries.
- Leona, M., J. Stenger, and E. Ferloni. 2006. Application of surface-enhanced Raman scattering techniques to the ultrasensitive identification of natural dyes in works of art. *Journal of Raman Spectroscopy* 37 (10): 981–92.
- Mabberley, D. J. 1993. *The Plant-Book: A Portable Dictionary of the Higher Plants Utilising Cronquist's "An Integrated System of*

- Classification of Flowering Plants*” (1981) and *Current Botanical Literature Arranged Largely on the Principles of Editions 1–6 (1896/97–1931) of Willis’s “A Dictionary of the Flowering Plants and Ferns.”* Repr. with corrections. Cambridge: Cambridge University Press.
- Schafer, E. R. 1957. Rosewood, dragon’s blood and lac. *Journal of the American Oriental Society* 77 (2): 129–36.
- Verri, G. 2007. An investigation of corrected UV-induced fluorescence for the examination of polychromy. M.A. thesis, Courtauld Institute of Art.
- Wouters, J. 1994. Dye analysis of Chinese and Indian textiles: With special emphasis on the recognition of *Miscanthus tinctorius* and *Sophora japonica* and the composition of green and blue colours. In *Dyes in History and Archaeology: DHA: Papers Presented at the 12th Annual Meeting, Brussels 1993*, ed. P. W. Rogers, 12–22. York: Textile Research Associates.
- . 1997. Dye analysis of nineteenth-century ikats from central Asia. In *ikat: Silks from Central Asia: The Guido Goldman Collection*, ed. K. Fitz Gibbon and A. Hale, 346–61. London: Laurence King Publishing in association with Alan Marcuson.
- . 1998. The dyes of early woven Indian silks. In *Samit & lampas: Motifs indiens = Indian Motifs*, ed. K. Riboud, 145–52. Paris: AEDTA; Ahmedabad: Calico Museum.
- Wu, Zhengyi, P. H. Raven, and Deyuan Hong, Chairs of the Editorial Committee. Flora of China Web site: <http://flora.huh.harvard.edu/china/mss/intindex.htm>.
- Yamauchi, K., Y. Taniguchi, T. Uno, eds. 2007. *Mural Paintings of the Silk Road: Cultural Exchanges between East and West: Proceedings of the 29th Annual International Symposium on the Conservation and Restoration of Cultural Property, National Research Institute for Cultural Properties, Tokyo, January 2006*. London: Archetype.
- Zhou Jiaju, Guirong Xie, Xinjian Yan, and G. W. A. Milne, eds. 2003. *Traditional Chinese Medicines: Molecular Structures, Natural Sources, and Applications*. 2nd ed. Aldershot: Ashgate.

Evaluating the Light Sensitivity of Paints in Selected Wall Paintings at the Mogao Grottoes: Caves 217, 98, and 85

James R. Druzik

Abstract: *Damage to the Mogao Grottoes from increased tourist visitation is a major concern to those responsible for protecting and interpreting the site. Threats include light damage to wall paintings caused by new artificial illumination, intended to improve the visitor experience. We evaluated this threat using a xenon arc lamp exposure apparatus on small samples provided from three representative caves (217, 98, 85) with painted walls. Samples had been characterized previously by Fourier transform infrared spectroscopy, Raman spectroscopy, scanning electron microscopy, and polarized light microscopy. The paintings were known to contain both inorganic mineral-based pigments and organic pigments, thought to be of the “lake” variety. Some paint samples were mixtures of both pigment types. Color-fading analysis showed a reasonable expectation that, except in one case, the organic pigments were no longer at high risk for continued rapid fading but that certain inorganic pigments already darkened from light exposure could be expected to continue this darkening trend. A long-term monitoring program, responding to future use of the Mogao Grottoes, is recommended.*

Color science has many tools for understanding the composition, structure, and stability of cultural artifacts. Their versatility, nondestructive nature, and sensitivity have been and will continue to be useful in informing preventive conservation decision making. One important aspect that bears on our immediate interest in the Mogao Grottoes is how color science informs risk assessment decision making in anticipating future risks and damages. In the Mogao Grottoes, Schilling (pers. com. 2005) observed that the color integrity and aesthetic harmony of the paintings diminish gradually as one advances toward cave openings from the darker inte-

rior spaces. Inversely, the paintings become brighter, contain richer hues, and are generally far better preserved in areas where less natural daylight has intruded. Often these effects can be dramatic. When these observations are untangled from other forms of deterioration, the hypothesis emerges that light has been partially responsible for the observed changes. Analysis of paint samples supports light’s historic involvement, and the question arises, Are the cave paintings still sensitive to light?

The sensible approach to assessing light sensitivity often employed in museums is to identify the components of an object and then carry out accelerated aging on modern analogs of those identified components. It would be far better in the Mogao Grottoes to assess light sensitivity directly on the actual wall paintings or on samples taken from the walls. In the 1990s a new instrument, the microfader, was designed and produced to address this need (Whitmore, Xun Pan, and Bailie 1999). Whitmore gives a detailed description of how the instrument functions and includes a list of parts, enabling the construction of the instrument. Several versions of the microfader have been assembled from standard optical components, including two built at the Getty Conservation Institute. Briefly, the source of illumination, a 75-watt xenon arc lamp, is filtered to remove the ultraviolet and infrared regions of the spectrum to reasonably match a filtered light source that could be used to display the artifact. The microfader focuses approximately 1 lumen on a spot 0.4 millimeter across. Since highly sensitive colorants fade predominantly from visible wavelengths (McLaren 1956), the instrument works very quickly—often a period of only 10 to 15 minutes is required per test exposure. For moderately sensitive materials, it is easy to extend the duration of

Table 1 Summary of Experimental Data and Blanks from Cave 85

Sample ID	Description	ΔE^*_{94} (30 min)	ΔE^*_{94} (60 min)	Results
Cave 85 S01	East wall, southeast corner. Plum-colored layer over white ground, probably an organic lake.	0.4	–	Possible change \geq BW3
Cave 85 S027	Green layer. Azurite transformation to atacamite suspected.	0.1	0.2	No detectable change
Cave 85 S019	Pinkish organic colorant. No Fe, Hg, or Pb.	0.2	0.2	No detectable change
Cave 85 S021	South wall, east side. Brown translucent color. Possible mix or organic lake (FTIR) with cinnabar (SEM-EDX).	0.6	0.7	Possible change \geq BW3
Cave 85 S02	Similar location to S01. Dark plum-colored organic lake (TLC) pigment over black.	0.5	0.45	Possible change \geq BW3
Cave 85 S028	Ceiling panel, east side. Definite red lead and cinnabar (SEM-EDX).	1.7	2.6	Definite change = BW2–3
ISO BW1	ISO Blue Wool #1 Standard	5.5	8.1	
ISO BW2	ISO Blue Wool #2 Standard	2.9	4.0	
Blank 1	Chrome oxide pigment in acrylic paint binder	≈ 0.1	≈ 0.30	
Blank 2	Raw umber in acrylic paint binder	≈ 0.1	≈ 0.02	
Blank 3	Deep Pink (British Ceramic Research Association) Standard	≈ 0.2	≈ 0.2	
Blank 4	Deep Pink (British Ceramic Research Association) Standard	≈ 0.1	≈ 0.1	
Detection Limit		0.4	0.6	

testing into the range of 5 million to 10 million lux-hours, or 30 to 60 minutes of device operation and even longer. Normally, estimates of lightfastness would then be adjusted to the behavior of well-characterized standards such as the ISO Blue Wool Standards (ISO 105-A01, 1994) run at the same time as the unknown colorants.

Light through the microfader is reflected, collimated, filtered, and focused onto a quartz fiber optic cable and routed normally to the area being tested. Reflected light is intercepted at a 45-degree angle ($0/45^\circ$ geometry) and via a second quartz fiber optic cable directed to a spectrophotometer. From there it is relayed to a computer for further processing and storage. Thus the instrument fades and measures color simultaneously.

Since future plans for the Mogao Grottoes include enhancing internal artificial lighting for visitor satisfaction, an assessment of illumination risks is important. Below we

describe our use of the microfader apparatus to determine the light sensitivity of samples from wall paintings in three representative locations: caves 217, 98, and 85.

Methods

Samples

We examined a total of 14 small (<2 mm diameter) samples of paint from wall paintings: 6 samples from cave 85, 4 samples from cave 217, and 4 samples from cave 98. The location and approximate composition of these paint samples are summarized in table 1 for cave 85 and in table 2 for caves 217 and 98. For the analyses, we also used three fading standards and eight controls. Samples had been characterized previously by Fourier transform infrared (FTIR) spectroscopy, Raman spectroscopy, scanning electron microscopy (SEM-EDX), and polarized light microscopy.

Table 2 Summary of Experimental Data and Blanks from Caves 217 and 98

Sample ID	Description	ΔE^*_{94} (30 min)	ΔE^*_{94} (60 min)	Results
Cave 217 E01	Red. North of east wall; 94 cm from north wall, 73 cm from ground. Vermilion detected by Raman spectroscopy.	0.5	0.8	Definite change = BW2-3
Cave 217 E02	Yellow. South of east wall; 23 cm from south wall, 43 cm from ground. Geothite detected by Raman spectroscopy.	0.3	0.2	No detectable change
Cave 217 E03a	Brown. South of east wall; 27 cm from south wall, 36 cm from ground. Unidentified fluorescence from Raman spectroscopy.	1.6	2.3	Definite change = BW2-3
Cave 217 E03b	Same as above.	1.4	1.7	Definite change = BW2-3
Cave 217 E03c	Same as above.	1.6	2.3	Definite change = BW2-3
Cave 217 E03 Average	Same as above.	1.8 ± 0.47	2.1 ± 0.35	Definite change = BW2-3
Cave 217 E04	Light red. North of east wall; 12 cm from north wall, 119 cm from ground. Hematite detected by Raman spectroscopy.	0.05	0.2	No detectable change
Cave 98 E01	Brown. South of east wall; 178 cm from south wall, 60 cm from ground. Oxylates, sulfates, quartz, mica, calcite detected by FTIR.	0.5	0.8	No detectable change
Cave 98 E02	Red. South of east wall; 121 cm from south wall, 101 cm from ground. Same FTIR results as for 98-E01.	0.2	0.3	No detectable change
Cave 98 E03	Orange. East of south wall; 127 cm from east wall, 126 cm from ground. Same FTIR results as for 98-E01.	0.2	0.3	No detectable change
Cave 98 E04a	Red. South of east wall; 88 cm from south wall, 376 cm from ground. Same FTIR results as for 98-E01.	0.3	0.3	No detectable change
Cave 98 E04a	Red. South of east wall; 88 cm from south wall, 376 cm from ground. Same FTIR results as for E01.	0.4	0.4	Possible change \geq BW3
ISO BW1	ISO Blue Wool #1 Standard	5.5	8.0	
ISO BW2	ISO Blue Wool #2 Standard	2.8	4.0	
ISO BW3	ISO Blue Wool #3 Standard	0.4	0.6	
Blank 1	Raw umber in acrylic paint binder.	≈ 0.1	≈ 0.2	
Blank 2	Raw umber in acrylic paint binder.	≈ 0.1	≈ 0.1	
Blank 3	Raw umber in acrylic paint binder.	≈ 0.2	≈ 0.1	
Blank 4	Raw umber in acrylic paint binder.	≈ 0.1	≈ 0.1	
Detection limit	From raw umber blanks (average + 3* S.D.)	0.4	0.6	

Experimental Setup and Approach

For our microfader testing on paint microsamples from caves 217, 98, and 85, the spectrometer was calibrated with a Spectralon (PTFE) white reference standard and dark current immediately prior to each sample. On the few occasions that it was possible, up to three one-hour-long replicate runs were averaged. Usually samples were provided with only enough surface area for a single measurement. A spectrum was acquired every 10 milliseconds, and 10 spectra were averaged at a time. Every 60 seconds the most current averaged spectrum was saved to disc. The 2° observer and D65 Illuminant were used.

Typically color change is evaluated by converting the full spectral curve from 380 to 780 nanometers to a three-dimensional color space that matches the manner in which the human eye responds to visible light. This color space was defined by the Commission Internationale de l'Éclairage (Berger-Schunn 1994)¹ and is used to calculate a value of color difference termed “ ΔE .” After having calculated a curve of color change (ΔE^*_{94}) versus time of exposure, it is necessary to interpret the results compared to known fading standards. As indicated earlier, we used the ISO Tests for Color Fastness (ISO 105-A01, 1994) as the basis for comparison.

Cave 85

Analysis

We had five pigment assignments for cave 85. Based on SEM-EDX, FTIR spectroscopy, Raman spectroscopy, and thin layer chromatography (TLC), identifiable pigment compositions were classified as (1) an organic lake, (2) a green copper-based mineral, (3) cinnabar (vermilion, mercury sulfide, α -HgS), (4) red lead (Pb_3O_4), and (5) carbon black. Samples So1, So2, So19, and So21 contained some portion of organic colorant. Cinnabar was also found in So21, and cinnabar and red lead were attributed to the pigment in So28. Sample So27 had a green layer assumed to be the transformation from azurite to atacamite ($Cu_2(OH)_3Cl$). The lone black attribution for carbon black was seen in sample So2.

The responses of the samples to microfading were expected to be small, owing to the great age of the wall paintings, so the duration of exposure was lengthened from ten minutes to an hour. The instrumental design has a noted drift, so we measured the color stability of three types of blanks: chrome oxide in an acrylic emulsion paint and raw umber in an acrylic emulsion paint (both Golden Paints) and

Deep Pink ceramic color tile (Ceramic Color Standards—Series II, British Ceramic Research Association/National Physical Laboratory). The detection limit was determined as the average ΔE^*_{94} for all blanks and their replicate measurements after 30 and 60 minutes, plus three times the standard deviation (Taylor 1997).

Results

Figure 1 summarizes the results of the cave 85 samples (So1, So2, So19, So21, So27, So28) and the fading standards (BW1–3). The detection limit is indicated as a solid red line (30 min.). Samples So19 and So27 are below the detection limit. Data are not shown for 60 minutes, since they were still below the 60-minute limit at twice the light exposure. The lack of response for So27 is not surprising as it is a green copper-based mineral and should no longer be expected to be sensitive to light, if indeed it ever was. Samples So1 and So2 are plum colored and were assigned as organic (probably a lake pigment) on the basis of their infrared spectrum, yet the change is detectably borderline. One would conclude that assigning this pigment as an organic lake is probably correct for So1 and So2 but that the present and future lightfastness is no longer limited to the higher sensitivity of Blue Wool 1–2 range but rather lowered to as much as Blue Wool 3 or 4, as is often the case with aged colorants. The same sensitivity can be ascribed to So21.

Sample So28, analyzed by SEM-EDX, contained mercury and lead, which presumably represents the pigments vermilion (from ground cinnabar) and red lead used by the

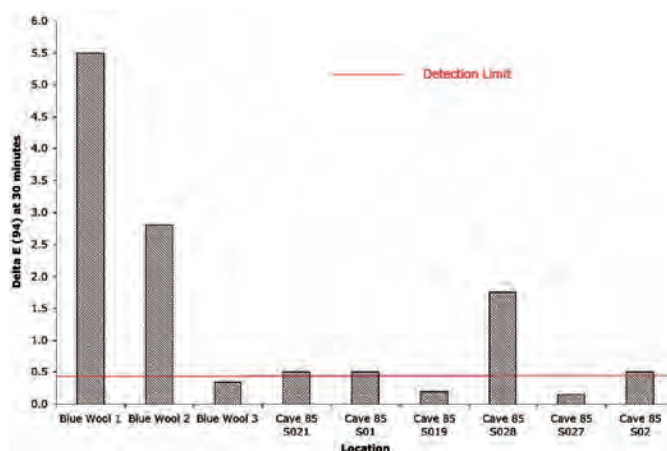

FIGURE 1 All data for cave 85 at 30 minutes.

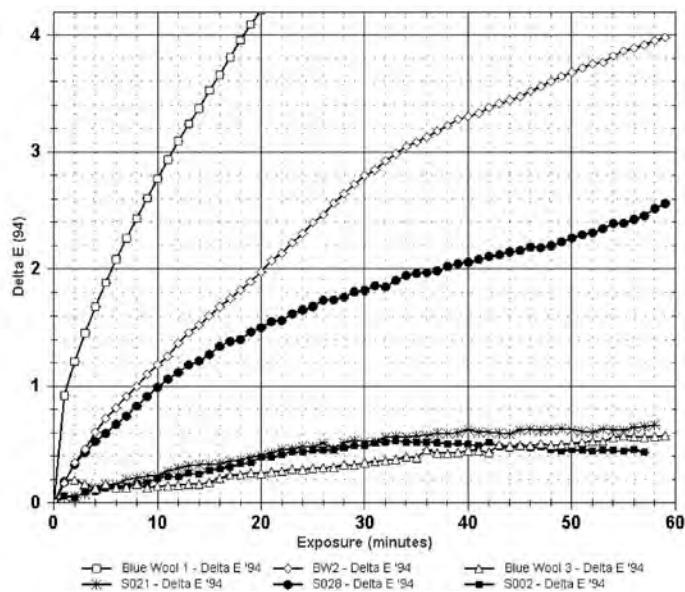

FIGURE 2 Cave 85, 60-minute comparison of ISO Blue Wools 1–3 and So02 (possible change \geq BW3), So21 (possible change \geq BW3), So28 (definite change = BW2–3).

original artists. It is not uncommon to find both cations present in a paint sample. So28 demonstrated the largest color change, $2.6 \Delta E_{94}^*$. Figure 2 graphically compares So28 to the fading standards and to two marginally reactive samples. Cinnabar (mercuric sulfide, vermilion, α - H_2S) has been known to darken from photo-induced effects since Roman times (Feller 2002).² The literature has many contradictory references to the lightfastness of vermilion, ranging from moderately permanent to unstable. During the National Gallery of Art Project carried out in the 1950s, many of the test panels of vermilion oil paints darkened within five years after approximately 650,000 lux-hours of diffuse daylight gallery exposure (Feller 2002).³

That red lead darkens from light exposure may be more complex. In fact, red lead exhibits a strong relative humidity dependency on the type of color change it undergoes. Saunders and Kirby (2004) subjected lac lake, red lead, azurite, and verdigris to 22,000 lux of illumination at 11, 32, 51, 75, and 90 percent relative humidity (RH). Darkening was most distinct for red lead at 11 percent RH and 32 percent RH, and the overall color change was toward lightening above 50 percent RH. Below 50 percent RH, the mechanism is thought to be a persistent increase of lead (IV) oxide from lead (II, IV) oxide. Above 50 percent RH, the reaction is driven to basic

lead (II) carbonate (lead white). Since the microfader presumably dries the faded spot (at about 40–48°C), the reaction logically follows the darkening pathway and is likely the same thing happening in cave 85 and elsewhere in Mogao. This underlines the complexity of Mogao cave painting deteriorations.⁴

Caves 217 and 98 Analysis and Results

Table 2 summarizes the samples and results for caves 217 and 98. Figure 3 shows the reactivity of sample E03, which had been supplied in a large enough quantity to conduct three measurements. No definitive chemical identification could be made on this sample, but an unidentified fluorescence was detected with Raman spectroscopy. E03 data represented ΔE_{94} as averaging 2.1. This is on a par with the most reactive sample examined in cave 85, but this “brown” sample shows all the colorimetric indications of undergoing a typical organic pigment fading-type reaction.⁵ However, sample E01, which did have mercury, continues the darkening noted for the other mercury-containing pigment sample (So28), even though the magnitude of the changes is smaller. For cave 98, none of the wall painting samples showed a detectable color response. Figure 4 plots all the data after 30 minutes for caves 217 and 98.

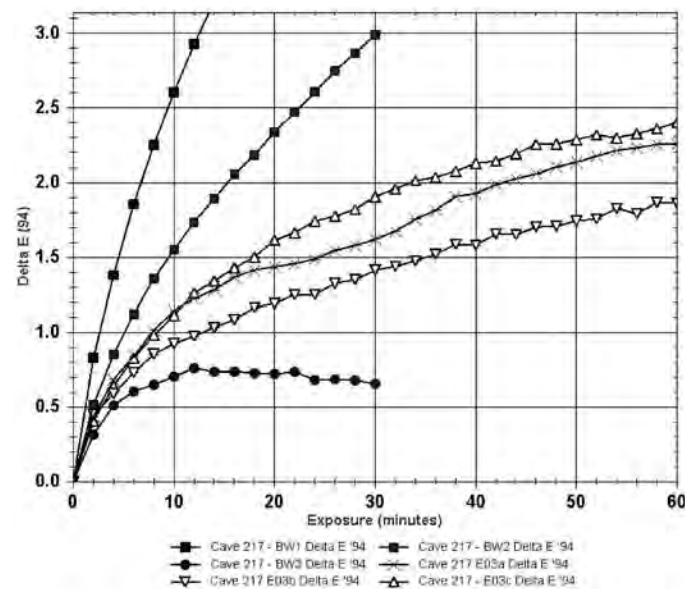

FIGURE 3 Data from cave 217 for three replicate measurements of sample E03.

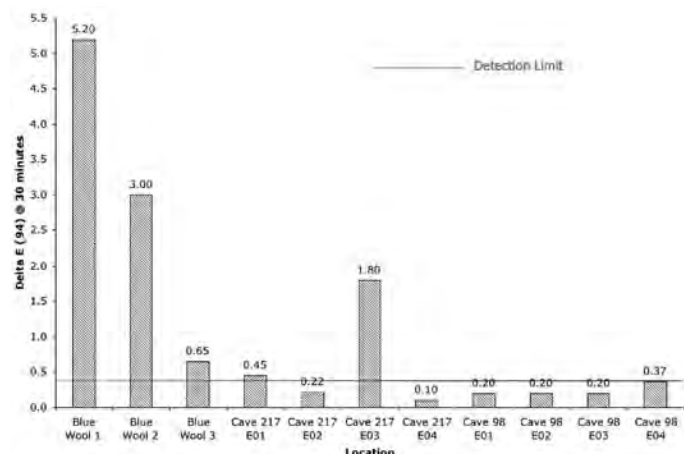

FIGURE 4 All data from caves 217 and 98.

Discussion

Taken together, the results from the three Mogao caves form a cohesive grouping, but they are still rather incomplete given the total extent of the wall paintings. Sample E03 from cave 98 was large enough to permit three replicate measurements. Since this sample represents one of the largest color changes, three replicates leave no doubt about the interpretation.

Half of the fourteen samples showed no change when exposed to nearly 6.8 million lux-hours of light. The remaining half of the samples suggested a possible or definite change; of those seven samples, three (21.4% of total) showed definitive changes ranging from 4.5 to 7.5 times the detection limit. As indicated in the experimental section, detection limits are determined by adding three times the standard deviation to the sample mean. Even then, terms such as *possible* and *probable* were used in reference to light sensitivity until the change was so large that it exceeded detection limits arbitrarily chosen to include five times the standard deviation added to the blank mean. Thus half the sample locations examined contained pigment components that were demonstrably light-sensitive—three for which a known sensitive inorganic pigment was detected, two with an organic pigment determined by TLC, and one for which no pigment assignment, based on characteristic cations or IR spectra, could be made but which exhibited a noteworthy Raman fluorescence.

Raman spectroscopy, FTIR spectroscopy, and SEM-EDX suggested that when organic colorants were suspected of remaining, their fading rates may have generally slowed

to below the detection limit of the microfader. Chemical analysis and color change analysis are fairly conclusive that vermilion and red lead are the principal pigments remaining vulnerable. However, there are so many unknowns that given the small number of caves examined, these current investigations can only be looking at the proverbial tip of the iceberg. Clearly more work is needed, preferably on samples large enough to support three replicate measurements each.

Conclusion

Color-fading analysis of samples from wall paintings in caves 217, 98, and 85 at the Mogao Grottoes showed a reasonable expectation that, except in one case, the organic pigments in the wall paintings were no longer at high risk for continued rapid fading. However, certain inorganic pigments already darkened from light exposure can be expected to continue this darkening trend. Thus there is no basis to assume that the wall paintings are light-inert, when half of the samples suggest or confirm otherwise.

A long-term monitoring program, responding to future use of the Mogao Grottoes, is recommended. It behooves the present caretakers of the site to embrace all future planning for artificial illumination in the caves with the spirit of preventive management.

Notes

- 1 The color space defined by the Commission Internationale de l'Éclairage is called CIELAB, where an L^* coordinate represents the lightness and darkness of the sample, a^* represents the red to green axis, and b^* represents the yellow to blue axis. From this location one is able to calculate a Euclidean distance relative to any other location, and this value of color difference is termed “ ΔE .” The CIE defined and updated the color difference equation in 1994 (ΔE^*_{94}) and in 2000 (ΔE^*_{00}). Ideally, ΔE^*_{00} would have been the equation of choice, but under some conditions it can render slightly problematic results. For a more detailed description of color difference equations, see Berns, Billmeyer, and Saltzman 2000; Fairchild 2005. All figures in this paper are plotted as a change in ΔE^*_{94} over time of exposure.
- 2 Feller relates the story told by the Roman author Vitruvius of the notary Faberius who ordered his house on the Aventine to be painted with cinnabar. After only thirty days, the walls had become so dark and ugly that Faberius ordered them repainted with another pigment.

- 3 Feller assumed that the vermilion darkening reaction was caused by the solid-state transformation of α - Hg_2S (specific gravity 7.71) to metacinnabar, α' - Hg_2S (specific gravity 8.18), but he remarked that he was unable to derive that from spectrophotometric techniques alone.
- 4 Some intra-paint layer chemical conversions seem to require higher humidity (and sodium chloride), azurite \rightarrow atacamite, and others, low humidity, lead (II, IV) oxide \rightarrow lead (IV) oxide.
- 5 This is indicated by increases in L^* , a^* , and b^* and not by the darkening and reduction in a^* for cinnabar.

References

- Berger-Schunn, A. 1994. *Practical Color Measurement: A Primer for the Beginner, a Reminder for the Expert*. Wiley Series in Pure and Applied Optics. New York: Wiley.
- Berns, R. S., F. W. Billmeyer, and M. Saltzman. 2000. *Billmeyer and Saltzman's Principles of Color Technology*. 3d ed. New York: Wiley.
- Fairchild, M. D. 2005. *Color Appearance Models*. 2d ed. Chichester, U.K.: Wiley.
- Feller, R. 2002. Studies on the darkening of vermilion by light. In *Contributions to Conservation Science: A Collection of Robert Feller's Published Studies on Artists' Paints, Paper, and Varnishes*, ed. P. M. Whitmore, 163–77. Pittsburgh: Carnegie Mellon University Press.
- McLaren, K. J. 1956. The spectral regions of daylight which cause fading. *Journal of the Society of Dyers and Colourists* 72: 86–99.
- Saunders, D., and J. Kirby. 2004. The effect of relative humidity on artist's pigments. *National Gallery Technical Bulletin* 25: 62–72.
- Taylor, J. R. 1997. *An Introduction to Error Analysis: The Study of Uncertainties in Physical Measurements*. 2d ed. Sausalito, CA: University Science Books.
- Whitmore, P. M., Xun Pan, and C. Bailie. 1999. Predicting the fading of objects: Identification of fugitive colorants through direct nondestructive lightfastness measurements. *Journal of the American Institute for Conservation* 38 (3): 395–409.

Origins of Moisture Affecting the Wall Paintings in Cave 85

Shin Maekawa, Liu Gang, Xue Ping, Guo Qinglin, and Hou Wenfang

Abstract: *The Dunhuang Academy has observed wall painting flaking and plaster detachment, sometimes followed by collapse of areas of plaster, in cave 85 and other caves of the Mogao Grottoes after major rainfall. A condition survey of cave 85 documented severely deteriorated areas in the deepest westernmost portion of the cave. Analysis of the earthen plaster and conglomerate bedrock revealed high concentrations of sodium and chloride and lesser amounts of other ions in the west wall. Laboratory tests on salts collected from the cave found that they began to absorb moisture from the air at 67 percent relative humidity. As part of the cave 85 wall painting conservation project an environmental investigation was undertaken to identify all possible origins of moisture that might result in dissolution, hydration, or deliquescence of salts in the rock, plaster and paintings, leading to soluble salt-activated deterioration.*

Open entrance doors allow rapid infiltration of outside air. This mechanism is believed to be the principal route for environmentally driven deterioration when the outside is humid. Based on this study, it is recommended that the entrance doors to cave 85 be kept closed and that visitors be restricted as much as possible during periods of high humidity in the summer months.

Cave temples at Mogao were carved into the conglomerate rock of the cliff that had been eroded by the Daquan River. The temples are carved into three or four tiers, and their sizes range from less than one cubic meter to more than several thousand cubic meters. Wall paintings were executed on double layers of mud-plaster, with a coarse base and fine finishing layers applied to the surface of the bedrock. Paintings in many caves on the base tier show similar deterioration,

principally on their west walls. It has been noted that areas of painted plaster tend to fall after prolonged rain.

Cave 85, a large cave (floor area approx. 106 m²/volume 850 m³) dating from the Tang dynasty, was flooded before the Daquan River was confined to its present channel. Prior to the installation of the concrete facade and aluminum entrance doors in the 1960s, the antechamber and the entrance to the corridor leading to the cave's main chamber were exposed to the elements at all times. From 1986 to 1998 entrance doors to the cave were left open during visiting hours to accommodate tours. However, in May 1998 the cave was closed to visitation for investigation into causes of the deterioration of the wall paintings and for its conservation.

A condition survey of the wall paintings recorded major losses and deterioration on the west walls and western portions of both north and south walls (Piqué, Wong, and Su Bomin, this volume). Damage ranges from flaking of paint layers to the separation or detachment of the plaster from the bedrock. Chemical analysis of both plasters and bedrock conglomerate (Schilling et al., this volume) revealed that both the plaster layer and the conglomerate contain deliquescent salts. The principal species were sodium, chloride, and lesser amounts of sulfate (primarily at the base of the cave where flooding had occurred).

Sodium chloride deliquesces above 75 percent over a range of temperatures. Although sodium sulfate deliquesces at a higher relative humidity (97–98%), it hydrates and swells at 65 to 71 percent.

The moisture equilibrium isotherm of a plaster sample taken from a fallen ceiling fragment was measured. The sample absorbed the moisture almost linearly with the relative humidity increase up to 75 percent. Moisture amounted

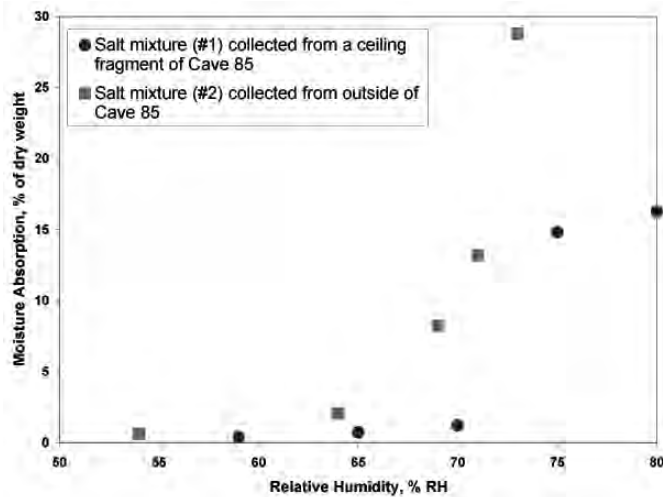

FIGURE 1 Moisture absorption of salt mixtures collected from the Mogao Grottoes.

to 1 percent of the dry weight and 1.5 percent during the desorption process in a 75 percent relative humidity (RH) environment. However, above 75 percent RH, absorbed moisture increased markedly. At 96 percent RH, nearly 4 percent moisture by weight was taken up by the plaster. This moisture uptake was similar to that of typical clay.

Figure 1 shows weight changes of salt samples extracted from a ceiling fragment of cave 85 that fell during an extended rain event in 1995 (salt mixture #1) and salt samples extracted from exposed conglomerate at the site (salt mixture #2) in various RH environments. Salt mixture #1 deliquesced between 70 and 75 percent RH, and its saturated solution produced a 74 percent RH environment. Salt mixture #2, on the other hand, started to hydrate at 67 percent RH and continued to increase its weight until the RH reached about 70 percent; a major weight increase occurred at about 71 percent RH.

Consequently, a five-year investigative environmental study was undertaken in cave 85 to identify sources of moisture that could cause the deterioration of the wall paintings by elevating the relative humidity to higher than 67 percent on and in the wall paintings.

Investigative Environmental Study of Cave 85

The investigative environmental study of cave 85 (1998–2002) began with a survey of possible sources for both liquid and vapor water. The following sources were considered.

For liquid water entering the cave:

- Surface infiltration of rainwater;
- Subterranean migration of the irrigation water from the poplar trees about 15 meters from the cave entrance; and
- Capillary rise of groundwater through the bedrock (see Tanimoto et al., this volume).

For water vapor entering the cave:

- Humid outside air in summer;
- Moisture generated by visitors; and
- Moisture transported through the bedrock by capillarity, groundwater, or rainwater channeled into fissures in proximity to the cliff face.

Environmental Monitoring

Environmental monitoring equipment was installed to identify moisture from the possible sources identified above. The following monitoring activities provided data for the environmental assessment.

Climate at the Site. In September 1989 an autonomous weather station had been installed on the cliff top of the site to record the climate. Since that time air temperature, relative humidity, solar radiation, wind direction and speed, rainfall, and ground surface temperature have been recorded. More than fifteen years of data were used for the analysis of meteorological data.

Climate in Cave 85. In December 1992 the Dunhuang Academy installed a temperature and relative humidity sensor in cave 85, along with adjacent caves, as part of its own investigation into the deterioration of wall paintings in the caves. This data set was also used for this study. Monitoring continued to April 1998 and then was expanded to measure spatial variations in the cave with the placement of a set of the temperature, relative humidity, and surface temperature sensors at four locations: the northwest and southwest corners, the center of the cave, and outside the entrance door.

Environmental Conditions in the Bedrock Conglomerate. Countless numbers of fissures are present along the cliff face. These fissures run parallel to the cliff face and generally perpendicular to the ground (Englekirk 1997). They may collect rainwater during events of extended or heavy rainfall. The collected moisture could eventually evaporate into the environment through cave walls, transporting salts in the process and enriching the surface.

Capillary rise of groundwater was considered not to affect the wall paintings due to the depth of the groundwater.

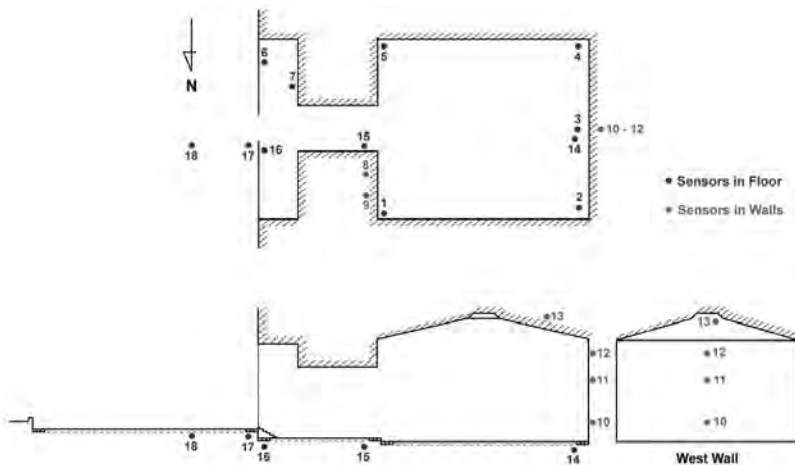

FIGURE 2 Locations of structural relative humidity and temperature sensors placed in the bedrock conglomerate of cave 85.

An evaluation of an existing water well confirmed the 30-meter depth of the groundwater at the site. However, several structural temperature and relative humidity sensors were placed in walls, as well as in the floor of the cave (fig. 2) to investigate variations of the environment in the bedrock conglomerate in cave 85 at 10-centimeter and 30-centimeter depths.

Moisture Seepage from Flood Irrigation in Cultivated Area. Mature poplar trees grow along the east face of the cliff to shade the walkway and protect the cave entrance

from wind-driven sand and are regularly flood irrigated. The cultivated area is especially close (~15 m) to the caves' entrances near cave 85. Therefore, while events of flood irrigation by the Dunhuang Academy were being recorded, moisture was monitored for seepage using structural temperature and relative humidity sensors at a 10-centimeter depth in the sand under the concrete tiles covering the area between the trees and the entrance of the cave.

Environments in Other Caves. The microclimate in several other caves was monitored: (1) those regularly visited as well as those closed to visitors, to isolate the impact of visitation on the caves' climate; (2) those at different tiers of the cliff, to understand the climatic variations due to vertical distance from ground level; and (3) those with low infiltration rates of outside air.

Findings and Discussion

Climate at the Site

The Mogao Grottoes are located in an arid environment. The site's annual rainfall average over a long period is about 25 millimeters; however, the amount varies greatly, for example, from 50 millimeters in 2000 to 3 millimeters in 2004. Rain events occur mainly in the three summer months—June, July, and August—when most visitors come to the site. Normally a rain event lasts less than a few hours; however, between 1989 and 2005 several sustained rain events occurred. One of them, in July 1996, lasted for nearly two weeks and resulted in the damage previously referred to. Temperature ranges from the -20°C in late January to the 40°C in mid-August. Daily averages range from -12°C in December and January to 20°C to 35°C in June, July, and August with a typical daily variation of 10°C to 15°C . Relative humidity normally remained between 10 and 30 percent throughout the year, although it is somewhat higher in winter. Occasional snow and rain events (normally less than a few days) cause spikes of elevated relative humidity (70–90%) as weather systems pass through the area (fig. 3).

Typical daily wind measures 4 to 7 meters per second from the south; however, occasional gusts reach 20 meters per second at the site during a sandstorm. The wind direction shifts daily from southeast to northwest at midday.

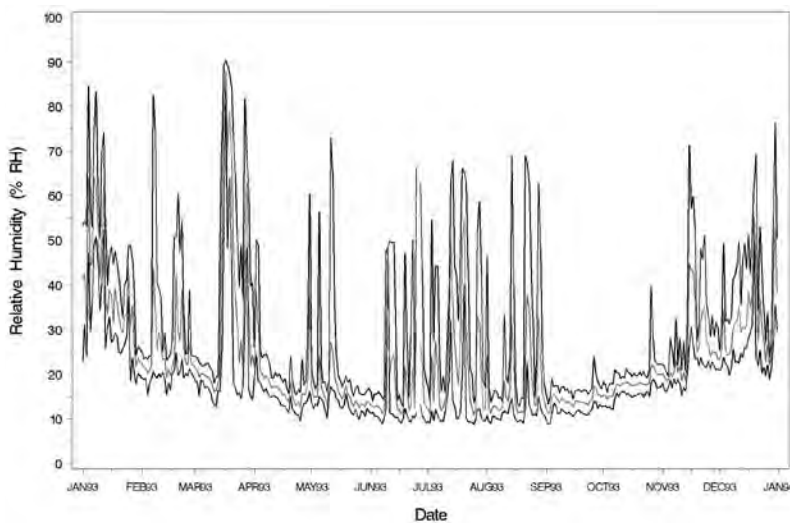

FIGURE 3 Typical annual variation of relative humidity at the Mogao Grottoes. This example is from 1993.

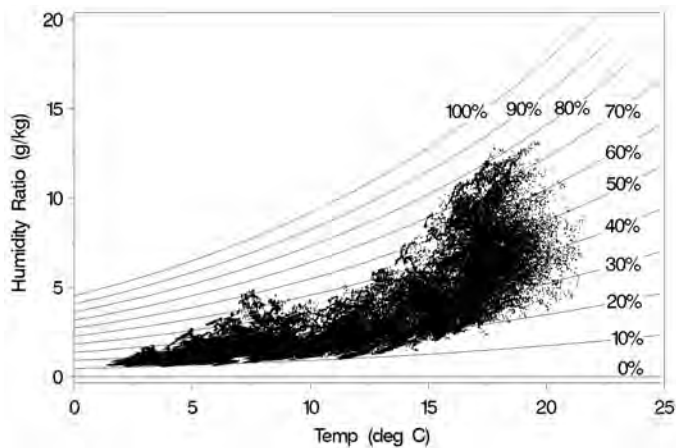

FIGURE 4 Temperature and relative humidity in cave 85 between 1993 and April 1998 (the cave was open to self-guided tours during operational hours), plotted on a psychrometric chart. Each dot represents a 15-minute (temperature and relative humidity) measurement. Conditions of higher than 75 percent RH were recorded annually during the period.

Climate of Cave 85

Since May 1998 cave 85 has been closed to visitors and the entrance doors have been kept closed most of the time. Over a five-year period the temperature ranged from -1.5°C in February to 20°C in September. Daily variations were only from 1.5°C in summer to less than 0.8°C in winter.

The relative humidity in the cave ranged from less than 10 percent in January and February to percentages in the 40s to 70s in June, July, and August. During rain events in summer months, the relative humidity increased from percentages in the 40s to the 70s, depending on the length and intensity of the event.

Prior to May 1998, when cave 85 was open to visitation (with entrance doors left open during hours of operation), the cave's climate variations were amplified. Figure 4 shows the temperature and relative humidity in cave 85 between January 1993 and April 1998 plotted on a psychrometric chart. Temperature ranged from 2°C to 22°C , and relative humidity annually reached 75 to 80 percent during rain events in summer. This may have been due either to moisture released by visitors in the cave or to infiltration of humid outside air through the open entry doors, or to both.

As expected, we documented the largest effects of the outside climate in areas closer to the cave's entrance, such as the antechamber, corridors, and east walls. The west wall was

least affected by the outside climate; thus it was the coldest in summer and warmest in winter. The temperature difference between the center of the cave and the west wall was approximately 1.5°C ; therefore, the west wall had 5 to 6 percent higher surface relative humidity than the center in late summer. However, the temperature difference between the east and west walls was typically less than 0.5°C ; this difference translated to less than 2 percent RH. Therefore, these climate variations between cave walls were minimal throughout the main chamber, eliminating the possibility that climate variations within the cave contribute to deterioration of the wall paintings.

Climate in Sealed Caves and Different Tiers

Caves 29, 310, and 423, which are ground-, middle-, and upper-tier caves, respectively, were monitored with their entrance doors closed and no visitation allowed. We observed that the climate inside these caves became warmer, and therefore drier, with increasing elevation on the cliff. The entrance doors to these caves were then covered with a plastic sheet to further reduce the infiltration of the outside air into the cave environment. The sealed environments were even drier in summer but more humid in winter than the cave environments with doors closed but not sealed. These facts indicate that the caves could be kept drier in summer by effectively reducing infiltration of humid outside air during rain events.

Irrigation Water

The grove of trees in front of the caves was flood irrigated daily during the summer months. We found wet sand under the concrete floor tiles of the walkway between the garden and the entrance to cave 85. Sensor readings verified the wet condition (100% RH with humidity ratio > 17 g/kg during the summer irrigation period). However, liquid water was confined to shallow depths, and its intrusion into the cave stopped just inside the entrance. Moisture dissipated before reaching the entrance of the corridor connecting to the east walls of the main chamber of the cave. Furthermore, the sand under the floor tiles between the garden and the cave dried out during the nonirrigation periods in fall and winter.

The Dunhuang Academy stopped flood irrigation in 2000 and replaced it with a drip system, which used a fraction of the water. Since that time, neither high humidity nor water has been found in the sand, even outside the cave's entrance. Furthermore, relative humidity levels in the cave floor remained the same as before. These findings further

indicate that irrigation water was not a source of moisture in the caves.

Rainwater through Fissures in Bedrock Conglomerate

To identify any relationship between variations in subsurface relative and absolute humidity and rain events, we compared both the short-term and long-term values in the west wall and in other parts of cave 85. Although we found significant seasonal variations of moisture at depths of both 10 centimeters and 30 centimeters that corresponded to climate changes at the site, there was no evidence that rain events affected wall humidity. This seemed to eliminate the possibility that fissures in the bedrock conglomerate act as rainwater reservoirs that feed moisture directly to cave surfaces. It was not possible, however, to survey the rock body comprehensively, as only areas where loss of painted surface had occurred could be used to insert probes.

High Humidity of the Bedrock Conglomerate in the West Wall

At 10 centimeters depth in the bedrock conglomerate of the west wall of cave 85, the temperature and relative humidity varied from 25 to 30 percent RH at 4–6°C in winter to 50 to 60 percent RH at 17–18°C in summer (fig. 5). These results indicate that the outside humidity strongly influences the shallow skin of the cave’s walls. At 30 centimeters depth, annual variations in temperature were similar to those at 10 centimeters depth; however, the relative humidity was higher and more stable (RH was 50% in winter and 60% in

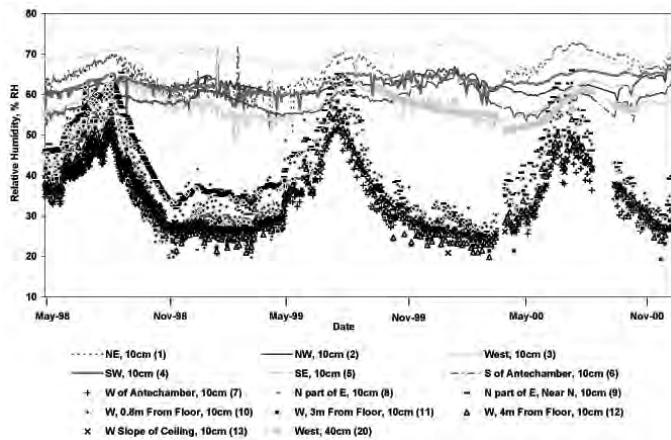

FIGURE 5 Annual variations of relative humidity in the bedrock of cave 85 between May 1998 and November 2000.

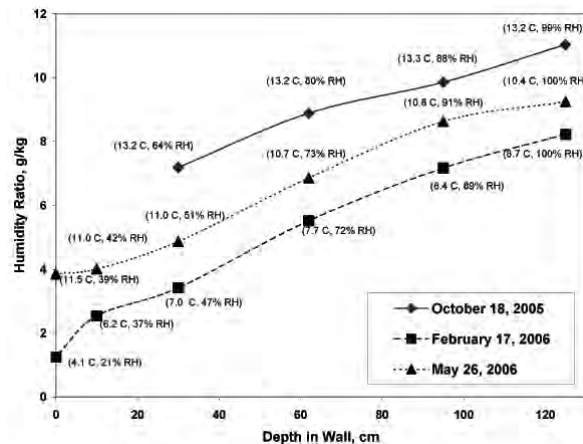

FIGURE 6 Humidity ratio of the bedrock in the west wall of cave 98 at various depths and seasons. Temperature and relative humidity are also indicated at each measured location.

summer). At 10 centimeters depth in the floor, the relative humidity was stable and varied from 65 percent in winter to 70 percent in summer. At the 30-centimeter depth in the floor near the west wall, the condition was least affected by the site’s climate at all measured locations: throughout the year, the temperature remained at approximately 10°C, and RH remained constant at approximately 85 percent.

Subsequent to the monitoring discussed above, in October 2005 three holes approximately 125 centimeters deep and 10 centimeters in diameter were cored into cave 98’s west wall, where all painting had been lost, and the adjacent floor to investigate the movement of moisture and salts. This cave is architecturally similar and has deterioration similar to that of cave 85. A series of structural temperature and RH sensors were inserted and isolated from each other and the chamber at depths of 125, 85, 60, 30, and 10 centimeters. At depths of about 100 centimeters the hole maintained 100 percent RH throughout the year. In both the wall and the floor, the relative humidity was above 75 percent at depths greater than about 60 centimeters; therefore, the NaCl in the bedrock should remain in solution at depths greater than 60 centimeters (fig. 6).

The moisture content gradient along the depth indicates that the moisture has been transported from deep bedrock to near the cave’s surface. However, the amount of moisture is small (due to the presence of large and numerous pebbles). The moisture transport rate is small in comparison to the high moisture removal rate at the surface (due to the

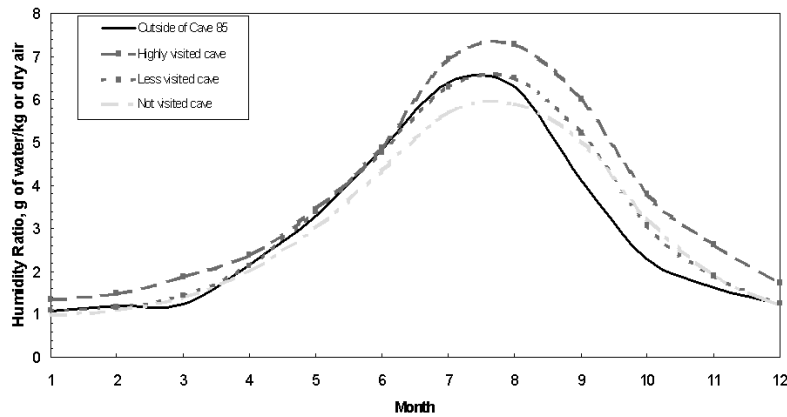

FIGURE 7 Monthly averages of humidity ratio at the site and inside highly visited, less visited, and not visited caves of the Mogao Grottoes.

normally dry cave air), so that less than 65 percent RH conditions were found at less than 30 centimeters depth throughout the year. Higher relative humidity in cave 85 as well as in the cave's floor at depths of 30 centimeters in comparison to that in cave walls indicated that concrete floor tiles, 5 centimeters thick, act as vapor retarders, reducing the moisture transfer from the floor to the cave air.

Impact of Visitors

In 1991 environmental monitoring was conducted in caves 323 and 335, which are architecturally similar to cave 85, though smaller. In the summer months approximately 5 percent higher relative humidity occurred in cave 323 (open) than in cave 335 (closed) (Maekawa et al. 1997).

Recent monitoring in cave 29, a medium-size (estimated volume 260 m³) and highly visited cave, included wall humidity measurements (fig. 7). Similar results were obtained: wall humidity rose by 5 percent (from 45% to 50% RH) during the peak months, a clear indication of the impact that visitors have on moisture in the air inside the cave.

Infiltration of Outside Air

Air infiltration rates of several large caves (55, 61, 98, 100, and 108) on the ground tier and architecturally similar to cave 85 were measured. These caves had periods of time when their entrance doors were left either open or closed. These caves were chosen because it was not possible to measure air infiltration rates in cave 85 due to the scaffolding that had been installed during the project. With the entrance doors

open, air infiltration rates were between 2 and 4 air changes per hour (ACH) and an order of magnitude lower (0.1–0.5 ACH) with the doors closed.

Air infiltration is mainly driven by the temperature difference between the cave interior and the outside: the larger the difference, the higher the infiltration rate. During the summer, temperatures in these caves were between 16°C and 20°C, and the outside temperature was normally in the 30s°C during the day and in the 20s°C during the night. However, the outdoor temperature dropped to the low 20s°C during rain events, producing smaller temperature differences with the cave interior temperatures and hence lower infiltration rates. After 4 to 5 air changes conditions inside and outside a cave will essentially be the same. This could occur in one to three hours, depending on the ACH of the particular cave. During summer rain events, the outside moisture content of the air increases from the normal value of 6.5 grams per kilogram to 12 to 13 grams per kilogram. With a cave infiltration rate of 2 to 4 changes per hour, the infiltration of humid outside air is equivalent to having 80 to 160 visitors in cave 85 during rainy days. This finding suggests that the moisture levels in the caves are predominantly influenced by the outside climate and the cave's air infiltration rate.

Documented Damage during a Prolonged Rain Event

Figure 8 is a combined plot of the rainfall, relative humidity of outside air, and relative humidity inside cave 85 between July 15 and August 2, 1996. On July 20, before a measurable rainfall event, the humidity in the cave rose from 42 to 75 percent RH, the humidity outside. This indicated that the outside humid air had infiltrated into the cave. Although the outside relative humidity decreased to less than 65 percent for the three days following the rainfall, the cave's interior relative humidity did not (the outside humidity remained high). Then a continuous rain event on July 26–27 coupled with the humid outside condition preceding and following the rain kept the cave's relative humidity above 75 percent. Although the total precipitation was low, the rainy condition continued until July 31.

After nearly eleven continuous days of above 65 percent RH in the cave, and with relative humidity continuously above 75 percent inside the cave for six of those days, the humid inside air had hydrated or deliquesced salts in the bedrock

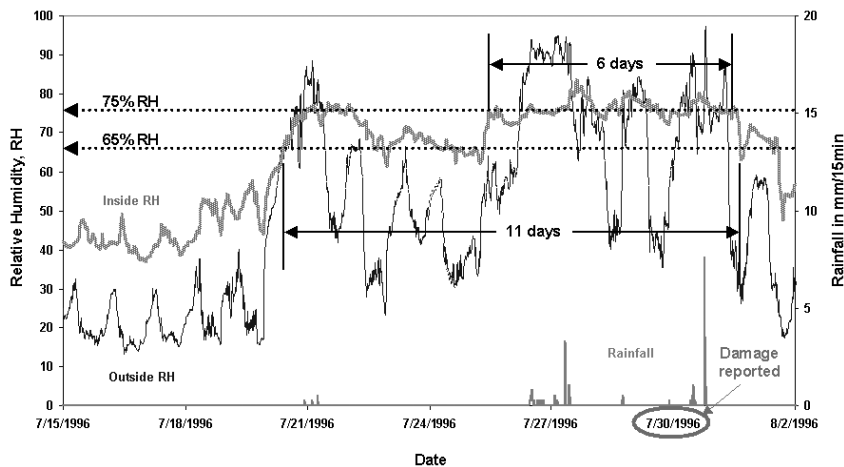

FIGURE 8 Combined plot of the rainfall, relative humidity of outside air, and relative humidity in cave 85 between July 15 and August 2, 1996. Bars extending from the baseline indicate the measured amount of rainfall for fifteen-minute periods. The Dunhuang Academy reported damage to the wall paintings in the cave on July 30.

conglomerate. This caused a large ceiling fragment of painted plaster to collapse, which was reported on July 30. The event demonstrates a relationship between extended humid or rain events, with prolonged elevated humidity above 65 percent RH, and damage to the cave walls.

Conclusions and Recommendations

External climate data from the Mogao Grottoes, as well as microclimate data from cave 85 supplemented with environmental monitoring from other caves, were used to identify sources of moisture in the cave that could cause the relative humidity to reach higher than 67 percent at the critical value established in the laboratory on extracted salts. We reached the following conclusions that apply specifically to cave 85 but more generally also to other caves. Climate variations occur seasonally and diurnally in the caves; however, they are below the critical relative humidity at which salt-related deterioration occurs. Flood irrigation of the trees in front of the caves does not affect the wall paintings.

- Saturated conditions (100% RH) exist in the bedrock deeper than 100 centimeters. This gradient can provide a transport mechanism for salts from the bedrock to the west wall of caves. (See Agnew et al., this volume, on mechanisms of deterioration.)
- Moisture released by many visitors increases humidity in caves; however, this is significant only in smaller caves.
- Caves with salt-related deterioration should remain closed to visitation on rainy summer days. If visitors are allowed into such caves, their numbers should be limited to minimize the amount of moisture they release.
- Real-time monitoring of relative humidity in susceptible caves should be considered.

Acknowledgments

The authors are grateful to Neville Agnew for technical guidance throughout the study. We acknowledge the support and discussions provided by members of the cave 85 project team of the Dunhuang Academy and the Getty Conservation Institute (GCI). Vincent Beltran, Pnina Evans, and David Carson of the GCI performed laboratory measurements and data processing.

References

- Englekirk, R. 1997. Geotechnical issues in conservation of sites. In *Conservation of Ancient Sites on the Silk Road: Proceedings of an International Conference on the Conservation of Grottoes Sites*, ed. N. Agnew, 147–58. Los Angeles: Getty Conservation Institute.
- Maekawa S., Zhang Yongjun, Wang Baoyi, Fu Wenli, and Xue Ping. 1997. Environmental monitoring at the Mogao Grottoes. In *Conservation of Ancient Sites on the Silk Road: Proceedings of an International Conference on the Conservation of Grottoes Sites*, ed. N. Agnew, 301–13. Los Angeles, Getty Conservation Institute.

Development and Testing of the Grouting and Soluble-Salts Reduction Treatments of Cave 85 Wall Paintings

Stephen Rickerby, Lisa Shekede, Fan Zaixuan, Tang Wei, Qiao Hai, Yang Jinjian, and Francesca Piqué

Abstract: *A major problem affecting the Mogao caves is the separation and occasional collapse of their painted earthen plasters from the conglomerate rock support. Formulating a treatment for this problem was a key focus of the collaborative project of the Dunhuang Academy and the Getty Conservation Institute to conserve the paintings of cave 85. Plaster separation in cave 85 was widespread and severe, affecting most of its west end, including, critically, the ceiling slopes, and substantial other areas. Injection grouting is used in wall painting conservation to reestablish adhesion between separated plaster and its support. Little research has been done on paintings on earthen plasters. In cave 85 compatibility was of paramount importance, and local earth was considered the only appropriate binder material. To counter the drawbacks of its density and shrinkage, the selection and proportions of the other grout components, in particular the filler materials, were crucial. These were adopted following characterization of a range of potential materials with regard to their appropriateness and functionality. Grout mixtures were put through laboratory trials, to assess performance characteristics and working properties. Additional testing included artificial aging. The use of an earthen grout with water as a fluidizer in cave 85 meant that treatment would activate soluble ions in the heavily salt-contaminated plaster. It was therefore necessary to develop a salt absorption system as a corollary to grouting. Testing was conducted on lightweight, highly absorbent materials, to be used in conjunction with the presses placed against the plaster to support it during and after grouting. Laboratory tests and in situ trials were devised to assess absorption and desorption of salts. The development and testing of these remedial interventions resulted in a comprehensive treatment methodology that has since been applied throughout cave 85.*

Among the most prevalent and serious problems in the painted Buddhist caves of Mogao is the separation and collapse of their earthen plasters from the conglomerate rock support.¹ These failures typically stem from defects in the creation of the paintings, such as shrinkage of the plasters on drying and their inadequate bonding to the poor-quality conglomerate. In many caves, salt-related deterioration further complicates these inherent faults. Past remedial treatments have included pinning with anchors and, in extreme cases, the detachment and transfer of paintings. Pinning has tended to concentrate stresses on already weakened plaster layers, leading ultimately to their further damage or complete loss (fig. 1).² The second approach is also discredited, based on recognition of the irreparable harm inflicted by detachment and transfer.³

Injection grouting—introducing an adhesive material with bulking properties—is now the treatment of choice for tackling the critical issue of plaster separation (Griffin 2004: 23). Grouting research, mostly related to lime-based wall paintings, spans the past two decades.⁴ A systematic methodology for development and testing has only been quite recently established, however, through the work of Griffin (1997, 2004) at the Courtauld Institute.⁵ For earthen wall paintings—both more numerous and more difficult to treat than lime-based paintings, owing to their greater susceptibility to a wider range of deterioration phenomena—grouting research is surprisingly rare. Further work by Griffin (1999) provides the only substantive basis for the testing and development of fully compatible earthen grouts.

The collaborative project to conserve cave 85 at Mogao was an opportunity to design a compatible earthen grout for large-scale application. Cave 85 is a large late Tang cave



FIGURE 1 Previous attempts to address the problem of plaster separation in cave 85 have included pinning with rods and anchors. These have tended to concentrate stresses on already weakened plaster layers, leading to further damage and loss. Photo: Stephen Rickerby

with over 350 square meters of painting. At the start of the project in 1998, much of its earthen plaster was dangerously separating from the conglomerate rock. Areas of separation were large, in terms of both area and volume, and were concentrated at the west end of the cave, most critically on the ceiling slopes. Due to the weight of the thick plaster, cracking and bulging were typical, and sudden collapses had occurred. Widespread soluble-salt contamination of the rock and plaster compounded these conditions.⁶ The treatment mandate was therefore exceptionally challenging, requiring not only the development and testing of an appropriate grout but also the corollary development of an efficient salt-reduction system.

The Nature of Grouting: Constraints and Issues

Assessment before, during, and after grouting is severely constrained by the concealed nature of both the problem and its treatment, and lack of control is a fundamental drawback (Griffin 1997: 3). Much depends on the judgment and experience of the conservator.⁷ At sites such as Mogao, where plaster

separation and collapse are major problems, many liters of grout may need to be injected.⁸ This scale of treatment far surpasses almost all other conservation interventions in terms of the quantity of materials applied. Grouting, moreover, is completely irreversible: a set grout is a nonextractable part of a wall painting. Since no one in conservation can claim to be fully satisfied with current knowledge of the condition and deterioration of wall paintings, or their long-term interaction with added conservation materials, it is essential that these formidable treatment constraints—imprecision, invasiveness and irreversibility—be fully recognized in grout design.

Compatibility

Because a grout becomes an integral part of a wall painting and retreatment is extremely difficult, it must be composed of materials that are as similar as possible to those of the original plaster, so that original and added materials behave similarly. Differences in application and function between an original plaster and a grout mean that compatibility must be qualified. Earthen plasters include aggregates and organic fibers, added to counter physical problems such as shrinkage. The properties imparted by these materials, however, are only partly measurable. Moreover, the same materials cannot be automatically transferred to a grout mixture, which needs to be easily injected, and substitute materials may need to be added to enhance grout performance.

Because physical compatibility with the original materials must be approximated, chemical compatibility is crucial. The clay fraction of an earthen plaster must be replicated in the set grout. However, the perceived drawbacks of earth, such as excessive shrinkage and low strength, have led to its avoidance as a grout binder.⁹ Instead, earthen wall paintings are routinely injected with unsuitable lime-based grouts;¹⁰ or, when earth is used, it is typically hybridized with synthetic adhesives, compromising its natural binding function. The development of a grout that relied entirely on earth as its binder—a principle first established and tested by Griffin (1999)—was adopted as a starting point on the cave 85 project.

Earthen Materials Analysis

The main components of an earthen grout and their functions and potential disadvantages are shown in table 1. To overcome the possible deficiencies, the mineralogical and clay-containing characteristics of the earth component must be known. With this data, an informed selection of the other material components can be made.

Table 1 Earthen Grout Components and Their Potential Disadvantages

Grout Component	Function	Potential Disadvantages
Binder earth	bind the solid components of the grout mixture	<ul style="list-style-type: none"> • high wet and dry densities • long drying time • high shrinkage
Fluidizer water	activate clay component	<ul style="list-style-type: none"> • damage to water-sensitive/soluble plasters and paint materials • activates salts
Filler(s)	<ul style="list-style-type: none"> • provide bulk and enhance internal cohesion • counter shrinkage • improve porosity and water vapor permeability • reduce density • improve viscosity (injectability) • increase drying rate 	<ul style="list-style-type: none"> • may compromise compatibility • may result in too low or too high strength
Additive(s)	modify grout properties further (optional)	<ul style="list-style-type: none"> • may compromise compatibility

Characterization tests performed on mud collected from the dry bed of the seasonal Daquan River, which passes in front of the Mogao Grottoes, and on plaster samples taken from cave 85 showed them to be mineralogically nearly identical (table 2).¹¹ The revealing difference is that the plaster contains about 35 percent more sand. It is likely that either the riverbed mud was adapted for use as a plaster by adding a sandy aggregate or another local soil source was used that already contained a sandy aggregate.

Based on the similarity of its properties to the original plaster, the riverbed mud was selected as the grout binder. The mud is characterized by its high silt content (71%), relatively

low swelling clays, and near-absence of sand. For earthen supports to function well, an equal distribution of silt, sand, and clay is desirable. Too much silt, for example, is neither a good binder nor an aggregate and produces a material prone to shrinkage and cracking. The sand in the original plaster reduced its silt component to about 45 percent and the clay component to about 19 percent, which was still sufficient to bind the plaster. For the grout, testing therefore focused on characterizing and selecting fillers that would, like the sandy aggregate and straw in the original plaster, modify its performance (counter shrinkage, provide internal cohesion, etc.) while also imparting necessary grouting properties.

Table 2 Earthen Materials Analysis

Particle-Size Distribution					
	sand (0.06–2 mm)	silt (0.002–0.06 mm)	clay (<0.002 mm)		
Riverbed mud	1%	71%	28%		
Cave 85 plaster	36%	45%	19%		
Cave 85 plaster (without added sand)	1%	69.5%	29.5%		
Mineralogy of Clay-Size Fraction					
	kaolin	illite	chlorite	smectite	mixed illite/smectite
Riverbed mud	—	50%	40%	—	10%
Cave 85 plaster	—	40%	30%	—	30%

Characterization of Fillers

Given the wide range of available filler materials, an informed preselection was made, predicated on the known deficiencies of the earth binder and on the modifying role of the other components in the original plaster.¹² In the original plaster, a high aggregate-to-binder ratio (4:1) and a significant amount of added straw helped to reduce undesirable shrinkage. The straw also added mechanical strength, countering the poor packing geometry of the rounded sandy aggregate. Unfortunately, neither straw nor substitute fibers are injectable. In the grout, the filler components therefore needed to improve on the particle-size distribution and morphology of the plaster aggregate. They also needed to have low wet and dry densities, as the condition of the paintings could not support excessive added weight.

These requirements were too demanding for one material alone, and at least two fillers were necessary. Pretrial selection was based on simple visual and microscopic characterization and on basic qualitative and semiquantitative laboratory tests. Parameters examined included particle size and morphology, wet and dry densities, amount and rate of water absorption and desorption, drying times after saturation, and material expansion and contraction. Chemical characteristics such as pH and soluble-ion content were also determined.

Earthen Grout Design and Testing: Performance Characteristics and Working Properties

The most consistent and comprehensive methodology for the development of grouts has been researched, tested, and established by Griffin (1997, 1999, 2004). Based on assessment of the performance characteristics and working properties of grout formulations, this approach underscored the development and testing of the cave 85 grout.

Performance characteristics relate to the long-term performance of the intervention and are most important because the stability of the wall painting depends on them (Griffin 1999: 11–12). For grouts, they include the following:

- minimal physical or chemical alteration of painting
- minimal volume change
- similar porosity to plaster
- similar water vapor permeability to plaster
- similar mechanical strength to plaster
- similar hygrothermal behavior to plaster
- no soluble ions
- good adhesion
- durability and chemical stability

- microbiological resistance
- low density
- retreatability (since grouting is irreversible)

Working properties are concerned with short-term behavior while a grout is still in a liquid state and include the following (Griffin 1999: 11):

- injectability
- viscosity
- tack (initial adhesion)
- reasonable setting time
- low toxicity

For the wall paintings of cave 85, two other working properties of the liquid grout were important:

- minimal water content
- slow water release

Quantitative and replicable laboratory trials, derived from national and international standards, have been established for assessing many of the performance characteristics.¹³ Because working properties are ephemeral, obtaining exact values is less important, and basic qualitative and semiquantitative tests have been designed or adopted for their assessment. Because working properties are also concerned with constraints imposed by the nature and condition of the specific wall painting, tests vary from case to case as well. For example, since the painted plaster in cave 85 is water-sensitive, simple tests were designed to compare and assess both the water content and the rate of water release of the earthen grout mixtures.¹⁴

Basic performance characteristics (e.g., linear shrinkage, density, and water vapor permeability) and working properties (e.g., wet density, drying time, water content, and rate of release) were evaluated initially. Grout mixtures that did not reach appropriate standards in these areas were omitted from further testing. Thus, although more than eighty grout formulations were tested, only a small proportion of these were subjected to the full range of testing, culminating in specific strength tests such as uniaxial compression, yield strength, Young's modulus, and modulus of rupture. The final components of the grout-development program involved a series of in situ tests and artificial aging trials.¹⁵

With compatibility a primary concern, it was essential to relate the specific values acquired from laboratory testing

to the nature of the original plaster. However, differences in application and function between an original plaster and an injected grout make comparison difficult. In addition, it is often not possible to obtain sufficient amounts of original plaster for comparable testing.

There are no clear-cut solutions to these problems, and approximation is unavoidable. For cave 85, a replica plaster was prepared as a comparative base. Its components—36 percent sand, 45 percent silt, 19 percent clay, and added straw—were derived from the results of the earthen materials analysis of original plaster samples (table 2). The replica plaster was then put through the same performance tests as the grout mixtures, to provide a set of comparative values.

Cave 85 Grout Formulation

The selected grout formulation is shown in table 3. Some of the key performance data for the grout and the replica plaster are shown in table 4. The largest component of the grout is inert glass microspheres. These are widely employed as lightweight fillers in conservation practice, and their usefulness as a grout component is well recognized.¹⁶ Being non-absorbent, they have the significant advantage over porous fillers of maintaining extremely low wet and dry densities. Their spherical morphology, regular surface texture, and extremely small particle size also promote good viscosity and injectability; and their lightness contributes to the suspension of other grout components in the fluid mixture. However, their spherical morphology contributes to poor

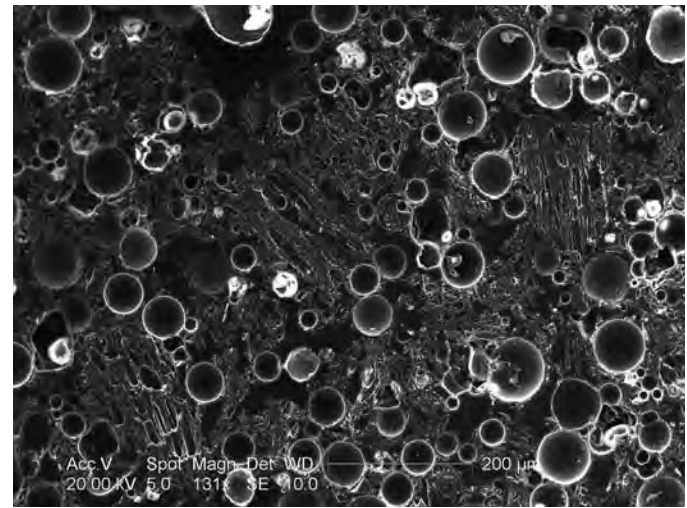

FIGURE 2 ESEM image of the formulated grout after setting, showing the distribution of the fillers in the earthen binder. The glass microspheres are clearly visible dispersed between the angular and variably sized pumice inclusions. Photo: Getty Conservation Institute

packing geometry, reducing internal cohesion: grout formulations tested with a higher proportion of glass microspheres were too weak.¹⁷ The pumice filler provides a counterbalance to this problem. Added as a relatively small proportion of the overall grout formulation, its variable and larger particle size and angular morphology favor internal cohesion (fig. 2). At the same time, the pumice has remarkably low

Table 3 Cave 85 Grout

Component	Material	Particle Size	Volume
Binder	washed and crushed riverbed mud	75 μm–0.6 mm	1
Filler 1	glass microspheres (Scotchlite K1*)	<75 μm	2
Filler 2	sieved pumice	75 μm–150 μm	1
Fluidizer	distilled water		0.66+
Additive	egg white (whisked)		5% (by volume of dry components)

Table 4 Key Performance Values

	Wet Weight (g)	Dry Weight (g)	Shrinkage (%)	Density (g/cm ³)	Water Vapor Permeability	Uniaxial Compression	3-Point Load (MPa)
Cave 85 grout	101	59.4	2.2	1.05	5 × 10 ⁻⁴	1.168	0.456
Cave 85 replica plaster	124.6	86.5	2.4	1.72	4 × 10 ⁻⁴	1.553	0.354

wet and dry densities compared to other angular fillers, such as sand.¹⁸

Adhesion is crucial. Two qualities are necessary: initial wet adhesion (tack) when the grout is injected and lasting adhesion once it has set. Synthetic adhesives have been added to earthen grouts to fulfill these demands, at risk of compromising the earth's natural binding function. Extensive research by Griffin, however, demonstrates the considerable adhesive and strengthening properties of egg white as a compatible protein additive, augmenting rather than substituting for clay binding properties.¹⁹ Egg white was therefore adopted for the cave 85 grout, whisked and folded into the mixture as a lightweight, air-entraining foam.²⁰ This also improves viscosity and injectability and prevents sedimentation. The egg white also makes up part of the fluidizer, allowing a reduced volume of water and restraining the rate of water release from the grout. Thus the egg component of the cave 85 grout is crucial for a variety of reasons.

Soluble-Salts Reduction

The use of an earthen grout with water as its fluidizer in cave 85 meant that treatment would dissolve soluble ions in the salt-contaminated plaster.²¹ Salts reduction was therefore required as an adjunct of grouting. Although salts reduction has a long history in conservation, usual techniques rely on the moisture supply and contact time of an applied (wet) poultice; research and practice are also mostly related to lime-based plasters.²² For cave 85, the moisture supply was instead water released from the grout. Patterns of moisture transfer and salt phase transitions in earthen plasters are poorly understood. However, aqueous reduction of salts, including treatment limitations and difficulties, has, in general, received considerable study, providing a basis for developing an approach for the particular issues in cave 85.²³

Testing focused on characterizing highly absorbent wipes that could be incorporated while dry into the presses placed against the plaster after grouting.²⁴ Efficient absorbency and low desorption were essential performance criteria; conformance and lightness were desirable working properties. Tests were devised to assess amounts and rates of moisture uptake and desorption by the wipes when placed against a wet substrate. Since in the case of aqueous extraction the time span for safe and effective absorption is known to be limited, it was anticipated that frequent replacement of the absorbent layers would be necessary to avoid harmful backward migration.²⁵

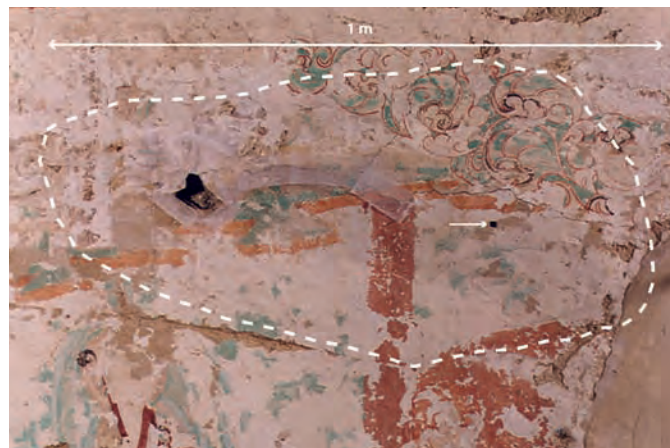

FIGURE 3 Grout Area 5 on the west wall of cave 85, showing the extent of a typical area of plaster separation. In the development of the soluble-salt reduction procedures, comparative microcore samples were taken *before* grouting and *after* grouting and salt-reduction treatment. The white arrow indicates the location of a *before grouting* microcore, taken in an area of unpainted plaster. The *after grouting* microcore would be taken adjacent to this, to minimize analytical error.

Verification by in situ trials was essential. Soluble-ion analysis of the removed absorbent materials was undertaken to evaluate extraction rates during the drying time of a grouted area. Maximum extraction occurred immediately after grouting, with a decline thereafter as the grouted plaster slowly dried.²⁶ To evaluate the redistribution of remaining ions in the wall painting, comparative microcore samples were taken before and after grouting. Potentially harmful salt accumulation at key internal interfaces—at junctures between the painting layers, the ground, the plasters, the deposited grout, and the conglomerate support—was a particular concern, and samples were therefore collected at depths corresponding to these strata. Results were variable, reflecting difficulties of sampling and interpreting data under extremely heterogeneous conditions.²⁷ Broadly, however, they pointed to a general lowering of soluble-ion levels in areas of grouting, particularly at key interfaces within the wall painting (figs. 3, 4).

Conclusion

Given the complexity of the conservation problems in cave 85, the development of the grouting and salts-reduction treatments was a substantial undertaking, which benefited

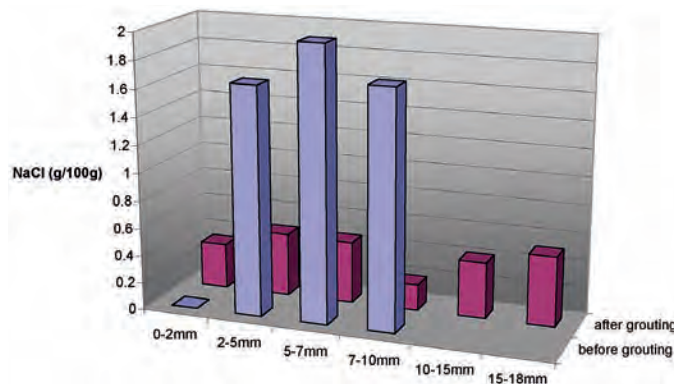

FIGURE 4 Soluble-ion (Cl⁻) results of microcores taken *before* and *after* grouting and soluble-salts reduction treatment for Grout Area 5 (also see fig. 3). The *before grouting* microcores attained an overall depth of 10 millimeters (mm) before reaching the void in the detached plaster; the result for the 0–2 mm increment is anomalous, probably due to loss of material during sampling. For the *after grouting* microcores, the 10–15 mm and 15–18 mm increments were taken through the injected grout, reaching back to the conglomerate rock. The results indicate a significant reduction in chloride levels after treatment.

from considerable previous research. In the context of much recent earthen materials conservation, the formulation of a grout that relied entirely on the clay fraction of its earth component for its binding function was a core accomplishment. In its physical and chemical properties, the grout is uniquely matched to the particular conditions and treatment constraints of cave 85. This also provides an important model for the way in which an intervention as difficult as grouting must be approached: particular circumstances of original technique, condition, and deterioration must be reflected in grout design.

Acknowledgments

The authors wish to acknowledge all members of the cave 85 project, whose individual and collective work contributed to the development of the grouting and salts-reduction treatments. We are fundamentally indebted to Sharon Cather, who, over the past decade, has significantly influenced the direction of grouting research.

Notes

- 1 The development and testing of the injection grouting and salts-reduction treatments of cave 85 were conducted at the Dunhuang Academy, Lanzhou University, and the Getty Conservation Institute from 1998 to 2002. Analytical procedures, data, and results are not reported in full in this paper but will be accessible from the Project Report Web site.
- 2 Although this problem has been little studied, see Leitner 2000 for research into the dynamics of structural failure associated with pinning painted plaster to suspended wooden ceilings.
- 3 For a recent discussion of the detrimental effects of wall painting detachment and transfer, see Brajer 2002.
- 4 See, e.g., Ferragni et al. 1984: 110–16; Botticelli et al. 1986: 177–79; Baglioni et al. 1997: 43–54; Barcellona et al. 1993: 637–43; Teutonico et al. 1994.
- 5 Building on Griffin's grouting research, a significant forerunner of the cave 85 grout was the design of a lime-based grout by Stephen Rickerby and Lisa Shekede, during the collaborative program of the Courtauld Institute and the Valletta Rehabilitation Project to conserve the late-sixteenth-century wall paintings by Filippo Paladini in the Chapel of the Grandmaster in the Magisterial Palace, Valletta, Malta, which was treated from 1998 to 2004 (publication forthcoming).
- 6 For a fuller discussion of the deterioration problems in cave 85, see Agnew, Maekawa, and Shuya Wei, this volume.
- 7 A range of nondestructive instrumental techniques have also been used for assessing plaster separation, including 3D laser scanning and modeling, ultrasonic pulse vibration and measurement, and infrared thermography. For examples, see Rickerby et al., on grout implementation, this volume.
- 8 Almost 300 liters of grout were injected in cave 85. The largest area of plaster separation was injected with 22 liters.
- 9 Griffin (1999: 57), however, found that earthen grouts shrank less than lime-based grouts, because they required lower water content to achieve the same consistency.
- 10 Inherently poor adhesion between lime- and earth-based materials has been noted by Griffin (1999: 13, 60) and Cather (2003: 169).
- 11 See note 1 above for further details.
- 12 Because fillers primarily alter the physical properties of a grout, they are usually selected for their chemical inertness. The possibility of using chemically reactive fillers in earthen grouts has not been explored. Materials such as calcite, silica, and ferric oxide, for example, have been shown to act as cementing agents in earth mixtures, forming chemical bridges between clay micelles that may reduce swelling (Foth 1990: 31).
- 13 See, e.g., Griffin 1999: App. D.

- 14 No testing standards have been specifically formulated for conservation grouts, and the wide range of national and international standards that exist have mostly been developed for cement-based mortars. Tests for performance characteristics and working properties carried out during the development of the cave 85 grout were based on those of Griffin (1997, 1999, 2004) and employed American Standards (ASTM) and Chinese Standards (CSTM). For full details, see note 1 above.
- 15 In situ trials included measuring the shear resistance of analogue panels grouted onto the rock conglomerate of the cave. Artificial aging of grouted plaster replicas, some doped with 2 percent NaCl, involved cycling these at 100 percent relative humidity for 48 hours, followed by their exposure to ambient relative humidity (ranging from approximately 20 to 40 percent) for 24 hours. See note 1 above for full details and results.
- 16 For a discussion of filler materials in conservation, including glass microspheres, see Smith 2000. Glass microspheres were used as a lightweight filler in the lime-based grout developed for the wall paintings in the Chapel of the Grandmaster in the Magisterial Palace, Valletta, Malta (see note 5 above).
- 17 Although SEM micrographs of glass microspheres show breakage of individual spheres, this does not occur on a sufficient scale to improve their overall packing geometry and promote better cohesion.
- 18 Pumice is also a natural pozzolana, though no pozzolanic reaction occurs in the cave 85 grout mixture due to the absence of calcium hydroxide (Ca(OH)₂).
- 19 Proteins are among the organic substances that react chemically with clays, one possible mechanism being the exchange of inorganic cations in the clay for organic ones; a further mechanism relates to the ability of amino acids to encourage clay flocculation (Griffin 1999: 21–22 and refs.). Amino acids are present in some quantity in egg white (Mills and White 1987: 76). Griffin found that egg white used as an additive in earthen grouts promoted tack and adhesion, increased plastic and liquid limits, and increased uniaxial compressive strength and modulus of rupture (Griffin 1999: 24–31, 35, 39–42, 44–45, 51–60, 63–65, 69).
- 20 Egg white also has a long tradition of use as an additive to lime plasters and mortars because of its adhesive properties (Sickels 1981: 27, 37), and it is still similarly employed by conservators in Austria (H. Leitner, pers. com.). Partly based on these precedents, it was also used in the lime-based grout to conserve the wall paintings in the Chapel of the Grandmaster in the Magisterial Palace, Valletta, Malta (see note 5 above). The preparation of the egg white in this grout in turn influenced its use in the development of the cave 85 grout.
- 21 Salt investigations indicate that the soluble-ion content in the plaster at the west end of the cave can be up to 4 percent (expressed in weight %) and that the most common ions are sodium and chloride. See Agnew, Maekawa, and Shuya Wei, this volume, for a fuller discussion of the salt contamination in cave 85.
- 22 An aqueous poultice removes salts from a wall painting in two stages: a *humidification* or *penetration* stage, whereby the poultice acts as a support for introducing water into the wall painting; and a *drying* stage, when the poultice provides a sacrificial evaporation zone into which salts migrate before being discarded (Tinzi 1994: 16, 18, 23). For a recent collection of papers on salt contamination of lime-based wall paintings and approaches to salts-reduction treatments, see Leitner, Laue, and Siedel 2003.
- 23 The main risks associated with salts-reduction treatments include the harmful redistribution of salts and preferential extraction of more soluble salts, leaving behind less soluble and potentially more damaging salts (Cather 2003: 169–70). For further discussion in relation to cave 85, see Rickerby et al., on grout implementation, this volume.
- 24 The materials tested were highly absorbent tissues, manufactured from absorbent cellulose fibers bonded to nonwoven polypropylene fabric. These were also tested impregnated with dried riverbed mud, to enhance their absorbency. For further details of the selected absorbent system, see Rickerby et al., on grout implementation, this volume.
- 25 During aqueous extraction, a concentration equilibrium is established between the filled capillaries of the substrate and those of the applied absorbent. At this point, backward migration may occur, due to greater capillary attraction of the substrate (see Grüner and Grassegger 1993). Thus while the absorbent materials tested for cave 85 were capable of absorbing large amounts of moisture, this potential was ultimately reversed when employed on a wet substrate.
- 26 For further discussion of the drying time of the absorbent presses in cave 85 and evaluation of salts reduction, see Rickerby et al., on grout implementation, this volume.
- 27 For the difficulties of salt sampling in terms of characterizing topographic and stratigraphic distribution, see Cather 2003: 168.

References

- Baglioni, P., L. Dei, F. Piqué, G. Sarti, and E. Ferroni. 1997. New autogenous lime-based grouts used in the conservation of lime-based wall paintings. *Studies in Conservation* 42 (1): 43–54.
- Barcellona, S., U. Santamaria, E. Borrelli, and M. Laurenzi Tabasso. 1993. Evaluation of injection grouting for structural

- strengthening of ancient buildings. In *Conservation of Stone and Other Materials: Proceedings of the International RILEM/ UNESCO Congress "Conservation of Stone and Other Materials: Research-Industry-Media" Held at UNESCO Headquarters, Paris, June 29–July 1 1993*, ed. M. J. Theil, 637–43. RILEM Proceedings, no. 21. London: E & FN Spon.
- Botticelli, G., M. Matteini, M. Arcangelo, and G. Lanterna. 1986. A mineral expansive material for readhesion operations on mural paintings. In *Scientific Methodologies Applied to Works of Art: Proceedings of the Symposium, Florence, Italy, 2–5 May 1984*, ed. P. I. Parrini, 177–79, 241. Milan: Montedison progetto cultura.
- Brajer, I. 2002. *The Transfer of Wall Paintings: Based on Danish Experience*. London: Archetype.
- Cather, S. 2003. Aqueous extraction of soluble salts from porous materials: Alternatives and contra-indications. In *Mauersalze und Architekturoberflächen*, ed. H. Leitner, S. Laue, and H. Siedel, 167–72. Dresden: Hochschule für Bildende Künste.
- Ferragni, D., M. Forti, J. Malliet, P. Mora, J. M. Teutonico, and G. Torraca. 1984. Injection grouting of mural paintings and mosaics. In *Adhesives and Consolidants: Preprints of the Contributions to the Paris Congress, 2–8 September 1984*, ed. N. S. Brommelle, 110–16. London: International Institute for Conservation of Historic and Artistic Works.
- Foth, H. D. 1990. *Fundamentals of Soil Science*. 8th ed. New York: Wiley.
- Griffin, I. 1997. Pozzolanas as additives for grouts: An investigation of their use in wall painting conservation. Postgraduate diss., Courtauld Institute of Art.
- . 1999. Earthen grouts in wall painting conservation: An investigation of their working properties and performance characteristics. M.A. thesis, Courtauld Institute of Art.
- . 2004. Pozzolanas as additives for grouts: An investigation of their working properties and performance characteristics. *Studies in Conservation* 49 (1): 23–34.
- Grüner, F., and G. Grassegger. 1993. Der Einfluß der Kompressentrocknung auf den Entsalzungseffekt: Laborversuche zur quantitativen Erfassung. *WTA Berichte* 9: 75–86.
- Laurenzi Tabasso, M., and P. Sammuri. 1984. Evaluation of mortars for use in conservation from the standpoint of the release of soluble salts. In *Preprints of the ICOM Committee for Conservation, 7th Triennial Meeting, Copenhagen, 10–14 September 1984*, ed. D. de Froment, 84.10.8–84.10.11. Paris: International Council of Museums in association with the J. Paul Getty Trust.
- Leitner, H. 2000. Technik oder Methode? Die Reinigung von Wandmalerei aus Sicht des Restaurators. In *Schmutz: Zeitdokument oder Schadensbild? 14 Tagung des Österreichischen Restauratorenverbandes, Altes Rathaus Wien, 14./15 Juni 1999*, ed. N. Lachmann and S. Miklin-Kniefacz, 46–54. Konservieren, Restaurieren, no. 7. Wien: Österreichischer Restauratoren Verband.
- Leitner, H., S. Laue, and H. Siedel, eds. 2003. *Mauersalze und Architekturoberflächen*. Dresden: Hochschule für Bildende Künste.
- Mills, J. S., and R. White. 1987. *The Organic Chemistry of Museum Objects*. London: Butterworth.
- Peroni, S., G. Tersigni, G. Torraca, S. Cerea, M. Forti, F. Guidobaldi, P. Rossi-Doria, A. De Rege, D. Picchi, F. J. Pietrafitta, and G. Benedetti. 1982. Lime-based mortars for the repair of ancient masonry and possible substitutes. In *Mortars, Cements and Grouts Used in the Conservation of Historic Buildings = Mortiers, ciments et coulis utilisés dans la conservation des bâtiments historiques: Symposium, 3–6.11.1981, Rome*, ed. ICCROM, 63–99. Rome: International Centre for the Study of the Preservation and the Restoration of Cultural Property.
- Rossi-Doria, P. 1986. Mortars for restoration: Basic requirements and quality control. *Matériaux et Constructions* 19: 445–48.
- Sawdy, A. 2003. The role of environmental control for reducing the rate of salt damage in wall paintings. In *Conserving the Painted Past: Developing Approaches to Wall Painting Conservation, Post-Prints of a Conference Organized by English Heritage, London, 2–4 December 1999*, ed. R. Gowing and A. Heritage, 95–109. London: Earthscan/James & James.
- Sickels, L.-B. 1981. Organics vs. synthetics: Their use as additives in mortars. In *Mortars, Cements and Grouts Used in the Conservation of Historic Buildings = Mortiers, ciments et coulis utilisés dans la conservation des bâtiments historiques: Symposium, 3–6.11.1981, Rome*, ed. ICCROM, 25–52. Rome: International Centre for the Study of the Preservation and the Restoration of Cultural Property.
- Smith, A. 2000. Characterisation of fillers. Postgraduate diss., Courtauld Institute of Art/English Heritage.
- Teutonico, J. M., I. McCaig, and J. Ashurst. 1994. The Smeaton Project: Factors affecting the properties of lime-based mortars. *APT Bulletin* 25 (3–4): 32–49.
- Tinzl, C. 1994. Removal of salts from lime plaster by means of poulticing. Postgraduate diss., Courtauld Institute of Art.

Implementation of Grouting and Salts-Reduction Treatments of Cave 85 Wall Paintings

Stephen Rickerby, Lisa Shekede, Fan Zaixuan, Tang Wei, Qiao Hai, and Yang Jinjian

Abstract: Because of extensive areas of earthen plaster detachment and the widespread presence of salts in the plaster and rock substrate, remedial treatment of cave 85 at the Mogao Grottoes was a singularly challenging task. The Dunhuang Academy and the Getty Conservation Institute devoted considerable resources to the development and testing of the principal remedial interventions: injection grouting and soluble-salts reduction.

Injection grouting is an imprecise and high-risk intervention. Pretreatment assessment, treatment control, and posttreatment evaluation are all inhibited by the concealed voids between the rock substrate and the plaster. The reduction of soluble salts is also hazardous for the wall paintings, as it risks harmful redistribution of the salts. Since salt reduction and grouting had to be undertaken simultaneously in cave 85, the already difficult treatment became riskier and more complex.

A well-defined treatment methodology was therefore essential. Meticulous preparation of the grout in small quantities maintained quality control and ensured that the grout was used in its optimal working state. A protocol for in situ treatment was developed to determine delivery options, injection points, and the localized consolidation and/or temporary facings required. Considerable planning was dedicated to the design and dimensions of the presses placed against the plaster after treatment, since these had to simultaneously provide physical support and absorb both moisture from the grout and dissolved salts from the plaster. Postinjection monitoring extended over a three- to four-week drying period. Analytical support before and after grouting determined soluble-salts reduction in treated areas. Given the difficulty of the treatments, the competence of the conservator in terms of practical

skills and in interpreting diverse and complex wall painting phenomena was a key consideration.

The remedial treatment of the late Tang dynasty (618–906) wall paintings of cave 85 at Mogao was a singularly challenging undertaking. The cave exhibited widespread separation of its painted earthen plaster from the conglomerate rock support and high levels of salt contamination in both the rock and the plaster. This created an exceptionally vulnerable and complex situation, whose remedy was the aim of the cave 85 project, a collaborative effort of the Dunhuang Academy and the Getty Conservation Institute. In preparation to treat the cave, the two organizations devoted some five years to the development and testing of the principal remedial interventions—*injection grouting and soluble-salts reduction*—alongside other interdisciplinary studies that focused on diagnosis of the underlying deterioration issues.¹ This allocation of resources reflected the difficulty of this single conservation endeavor. From 2002 to 2005 the injection grouting and salts-reduction treatments were implemented throughout cave 85.

Challenges Posed by Cave 85

The significant constraints of both injection grouting and soluble-salts reduction are accentuated in the case of earthen plasters, such as those at Mogao. Since the cohesion of the plaster depends largely on its moisture content and since a high moisture content can lead to loss of cohesion and even failure, the risks of employing aqueous-based treatments are obvious. Dangers clearly increase when the plaster layers are thick, heavy, and severely cracked and



FIGURE 1 Detail of cave 85 showing where painted earthen plaster has separated and fallen away from the underlying conglomerate rock. A metal cross-brace was bolted into the rock by Dunhuang Academy conservators before the collapse but failed to prevent it. Photo: S. Rickerby

bulging, as was the case in cave 85. On the west wall, the part of the cave most affected, approximately 70 percent of the 57 square meters of plaster was separated from the rock. Huge risks were posed by the typically large size of individual areas of plaster separation, some extending over 1 to 2 square meters, with a gap between the plaster and the rock of up to 4 centimeters (fig. 1). The diverse painting materials of cave 85—the preparatory ground, pigments, organic colorants, and glazes—are also all extremely water-sensitive and in some cases water-soluble.

In addition to the failing and vulnerable original materials, there was the coincidence of high levels of salts in areas of major plaster separation, especially at the west end of the cave.² Moreover, Cave 85 had a recent history of repeated remedial intervention, including widespread consolidation on several occasions with a polyvinyl acetate (PVAC) and polyvinyl alcohol mixture, which had only exacerbated persistent deterioration problems.

Treatment Constraints and Issues

Since grouting is irreversible, the twofold emphasis of the development of this treatment was compatibility of materials and “retreatability.” And since the concern was to effect the structural rescue of the wall painting, the set grout and the earthen plaster had to function well together, possessing the same or similar performance characteristics.

To this end, a decision was made to establish, through analysis, a local soil source that was physically and chemically similar to the earth component of the cave 85 plaster and to use this as the principal binder of the formulated grout (see Rickerby et al., on development and testing, this volume).³

With earth as binder, water was required as the grout fluidizer. This meant that soluble salts in the plaster and rock would be mobilized as a result of moisture migration. Salts-reduction measures therefore had to be developed and implemented as a corollary of injection grouting.

Both injection grouting and salts reduction are fraught with imprecision and risk. In the case of injection grouting, the concealed nature of the plaster voids constrains pretreatment assessment, as well as full control of the intervention and its posttreatment evaluation.⁴ Despite this, the treatment was concerned with wall paintings at the point of collapse and, therefore, with fundamental issues of plaster instability. Not only was the intervention a precarious one, but the risks were largely unquantifiable.

The reduction of soluble salts is also hazardous for wall paintings, potentially resulting in the harmful redistribution of the salts (Cather 2003: 167–72). Modern conservation practice favors environmental control as the most effective means of mitigating the activation mechanisms that lead to salt-related deterioration of wall paintings (Sawdy 2003: 95). Although ongoing environmental control also underpinned the remedial interventions of cave 85, salt-reduction treatment was unavoidable. However, the aqueous reduction of salts has received considerable study, making this a viable intervention despite its well-documented limitations.⁵

Treatment Methodology

Given the problems of assessment before, during, and after grouting and salt reduction, in situ application of both treatments has traditionally depended on the experience and judgment of practicing conservators. One unfortunate consequence of this has been reliance on visual evidence of “success” rather than on analytical evaluation. The cave 85 project offered an opportunity to address this situation by establishing a well-defined treatment methodology that incorporated analytical surveillance of results.

Pretreatment Assessment

A rigorous assessment of areas of plaster separation—aided by graphic and photographic documentation and written logs—was undertaken prior to grouting. The location and



FIGURE 2 Cracks in the painted earthen plaster in cave 85. Photo: S. Rickerby

extent of the plaster voids to be filled were determined by visual inspection and simple acoustic methods.

Fundamental aspects of the nature and extent of the plaster separation were established. Particular concerns were the gap between the plaster and the rock conglomerate (whether the plaster was flat or bulging or both); the condition of the plaster; the age, extent, and configuration of plaster cracks (fig. 2); and the perimeter of the zone of plaster separation. Aspects of condition, such as areas of paint flaking and plaster decohesion, were also recorded in order to identify stabilization treatments required before grouting and to determine grout delivery options and appropriate injection points.

One example may illustrate the role of the conservator. An original cause of plaster separation in cave 85 is attributed to shrinkage of the earthen materials on drying. Historic cracks associated with this failure could typically be identifiable because paint is carried over them. If the original cracks remained unchanged and the paint undisturbed, this would signify relatively stable conditions. If additional newer cracks later developed, disturbing the paint, this could point to a renewed threat of collapse and to the need for grouting. Categorizing degrees of risk in either case is not straightforward, and making such distinctions in practice required considerable judgment. An awareness of

diverse original plastering and painting techniques, of complex deterioration mechanisms and their effects on present condition, and of difficult treatment procedures and their limitations was essential.

Grout Preparation

The selected grout formulation was a product of considerable refinement regarding proportions of components, range of particle sizes, and particle morphology. Earth was its principal binder, and the two main fillers—glass microspheres and sieved pumice—were carefully formulated to counter potential drawbacks such as shrinkage and weight. Egg white was also added, imparting additional adhesive and strengthening properties. Prior to its use in cave 85, the grout was tested extensively (for *performance characteristics* and *working properties*), and aging trials were performed and assessed (Rickerby et al., on development and testing, this volume).

To maintain quality control, consistent preparation of materials was required before they were combined. Reliable grout formulation was maintained by establishing a strict protocol for measuring and combining the wet and dry components. Small quantities were produced to ensure accuracy. Given the relatively fast initial setting of the grout, this protocol also ensured that the mixture was used in its optimal working state.

In Situ Preparations

The combined treatment procedures involved considerable logistical preparation and coordination. Determining the size of individual grouting areas was essential for determining the size of the presses that would be placed against the plaster after treatment. Since these presses not only provided physical support after grouting but also incorporated highly absorbent layers to contain moisture released from the grout, press dimensions had to anticipate lateral moisture movement by a generous margin.

Other in situ measures included preparing injection points and implementing stabilization measures, such as the application of **localized temporary facings**, **localized consolidation**, and the fixing of paint flakes. Where possible, existing holes in the plaster were used as entry points for catheters and needles; on occasion, new holes had to be drilled, and these were made through areas of paint loss (fig. 3).

Grouting

As with all other aspects of treatment in cave 85, grouting partly evolved in relation to practical experience and



FIGURE 3 A grout catheter placed in an insertion point that has been stabilized with a temporary facing. Photo: S. Rickerby

acquired judgment. With this experience, protocols were put in place for the preparation of grouting equipment and materials and the sequencing and optimizing of specific treatment procedures. However, each area to be treated had to be assessed individually, since conditions varied from one area to another.

Because of the risks, caution and restraint were essential. Usually four conservators were involved in the grouting of a single area: two preparing the grout and syringes, one delivering the grout, and the other manually checking and supporting the plaster (fig. 4). Since grouting is a team exercise, effective communication was key. Oversight was maintained by compiling treatment logs detailing the amount of injected grout and the quantities of added water required to fluidize the basic grout mixture in response to differing grouting situations.

Importantly, the purpose of grouting was not to fill all voids. Many large voids were only partly filled to avoid adding too much additional weight. In such cases, the aim of grouting was to break up the internal volume of the voids and to provide strategic “anchoring.” Nevertheless, some



(a)



(b)

FIGURE 4 Grouting was a team exercise. Dunhuang Academy conservators (a) prepare grout and syringes and (b) deliver grout while supporting the treated area. Photos: S. Rickerby

idea of the scale of grouting in cave 85 can be gauged by the amount of grout injected: a total of nearly 300 liters.

Soluble-Salts Reduction

To absorb and contain moisture released from the grout, carrying with it dissolved salts from the original plaster and rock, absorbent tissue layers were incorporated into the presses that were placed against the treated plaster (fig. 5).⁶ This absorbent system was selected after extensive testing. Its efficacy in practice was dependent on monitoring and timing and involved teamwork between the project conservators and the conservation scientists.

While the materials used in the presses were capable of absorbing large amounts of moisture, this process could be reversed in situ. It was therefore important to remove and replace the absorbent layers frequently (to avoid reabsorption of moisture and salts by the plaster).⁷ Although the responses of treated areas to the salts-reduction procedures differed markedly depending on original technique and condition, analytical tracking of soluble salts in the absorbent layers established broad absorption patterns.⁸ Maximum absorption occurred immediately after grouting, with a decline



FIGURE 5 A customized press placed against treated plaster for support and to absorb moisture released from the grout. Photo: S. Rickerby

thereafter as the grouted area slowly dried completely, typically over three to four weeks; in the final stages of drying, little salt was detected. Based on these findings, the absorbent layers were changed up to three times a day in the first few days after grouting, decreasing to twice a day for much of the remainder of the drying period. Only in the final stages of drying was it safe to leave the absorbent presses in place for longer periods.

It was also necessary to check that harmful salts had not become redistributed in the grouted plaster. This was done with microcore samples taken before and after grouting (in areas of unpainted plaster) to establish soluble-ion levels at key interfaces within the grouted wall painting stratigraphy.⁹ This level of analytical surveillance was a key component of treatment implementation, involving the conservation team in sample taking and evaluation of results.

Posttreatment Monitoring and Care

Posttreatment monitoring of the grouted areas was intensive, extending over the three- to four-week drying period. During this time, a daily regimen was established for changing the absorbent layers in the presses—from preparing the absorbent materials in the laboratory to changing them in situ—and logging and evaluating the frequency of changes. To monitor overall drying rates, an infrared thermometer was used to compare spot measurements of treated (damp) and adjacent untreated (dry) areas until equalized temperatures were reached.

Daily checking and care of grouted areas coincided with the press changes, both measures requiring an awareness of early signs of salt-related and other deterioration. To prevent salt crystallization on or immediately below the surface of the paintings, it was necessary that monitoring—and any minor remedial treatments, such as re-laying lifted paint flakes—be completed swiftly, so the absorbent presses could be replaced quickly to reestablish capillary continuity.

After complete drying of the grouted areas, posttreatment care continued in other forms. Surface salts still present posed immediate risks that could be partly remedied. An ultrasonic humidifier that projected a fine mist of heated water onto the surface of the treated areas was used to dissolve the salts, which were then removed by tamping with highly absorbent wipes (fig. 6).¹⁰ This approach provided considerable control, limiting the amount of moisture added. As with the salts-reduction procedures, these additional measures were monitored by tracking chloride ion levels in the used absorbent wipes and by sampling the plaster to check



FIGURE 6 An ultrasonic humidifier being used to dissolve surface salts on the treated area of a wall painting. Photo: S. Rickerby

salt redistribution patterns. Results indicated that the treatment was capable of reducing surface salts without causing their adverse redistribution.

Other Remedial Interventions

Other treatments were carried out in cave 85, such as the fixing of flaking paint, localized consolidation of powdering plaster and/or paint, and new repairs to cracks and losses in the original plaster. Although these treatments were less extensive and less complex than the injection grouting and salts-reduction interventions, they nevertheless shared the same overall treatment methodology, which emphasized compatibility between original and added materials.

Furthermore, the earth and PVAC mixture used in previous repairs was removed and replaced with an earthen repair mixture with a composition based on materials analysis of the original plaster.¹¹ Analysis indicated that animal glue was used as an original plaster sealant, and gelatin was therefore selected as a compatible substitute to use as both a localized paint fixative and a plaster consolidant.¹² Prior to their use in cave 85, all additional treatment materials underwent extensive testing and assessment, including tests of performance characteristics and working proper-

ties, both in the laboratory and in situ; artificial aging trials were also performed.¹³

Conclusion

Until remarkably recently, it was customary conservation practice to detach wall paintings from their original support when loss of adhesion threatened their survival. Their remounting on artificial supports was then seen as a rational treatment solution to correct problems of deterioration. Recognition of the irreparable harm inflicted by these actions—both to the wall paintings and to the places they once occupied—and their failure to halt subsequent deterioration of the detached paintings have almost brought these practices to a halt. This fundamental change came about through the development, and acceptance, of injection grouting as a practical treatment alternative. That acceptance has been slow, and unnecessary detachment of wall paintings persists.

In this context, the practice of simultaneous injection grouting and soluble-salts reduction in cave 85 was a significant achievement. While much attention has been given recently to grout research and development, few other conservation projects have implemented compatible earthen grouting on such a major scale as this one carried out at Mogao.¹⁴

It is important, however, to appreciate fully the nature of the major treatment interventions undertaken in cave 85. Considered in isolation, neither is a panacea: injection grouting addresses a deterioration crisis, not its causes; and salts-reduction procedures cannot be viewed as a means of solving salt-related deterioration. It is also generally recognized that these treatments are imprecise and usually highly interventive. Because they are applied to wall paintings in conditions of advanced deterioration, both treatments are inherently risky, often in unpredictable ways.

Nevertheless, both interventions were required in cave 85, where they also had to be implemented on a large scale. Treatment therefore relied on a prior program of intensive testing and development and on analytical backup during implementation. The collaborative—and overlapping—roles of the conservator and the conservation scientist were key to this process. Remedial treatment was also only undertaken in a wider context of environmental investigation and diagnosis of the principal deterioration problems (Agnew, Maekawa, and Shuya Wei, this volume). Given the essentially limitless supply of salt in the painted plaster, long-term

conservation in cave 85 is ultimately dependent on localized control of the activation mechanisms of salt deterioration, through appropriate environmental intervention.

Acknowledgments

The principal authors wish to acknowledge all members of the cave 85 project, whose individual and collective work contributed to the success of the treatment program. Special thanks are due to Po Ming Lin. We also wish to thank Sharon Cather for generously sharing her knowledge and advice on the issues discussed in this paper.

Notes

- 1 For the development and testing of the injection grouting and salts-reduction treatments of cave 85, see Rickerby et al., this volume. Analytical procedures, data, and results from the Mogao Cave 85 Project Report will be forthcoming on the Getty Web site (www.getty.edu). For discussion of other areas of diagnosis and research related to the cave 85 project, see Agnew, Maekawa, and Shuya Wei; Maekawa et al.; and Schilling et al., this volume.
- 2 See Agnew, Maekawa, and Shuya Wei, this volume, for a discussion of the salt contamination in cave 85.
- 3 Particle-size distribution and characterization tests performed on samples of original plaster taken from cave 85 indicated that it was composed of 36% sand and 64% riverbed mud, with added straw. For more details of the earthen materials analysis carried out for the cave 85 project, see Rickerby et al., this volume.
- 4 Although manual acoustic methods remain the norm for detecting, recording, and, to some extent, qualifying the risks posed by plaster voids in wall paintings, various nondestructive instrumental techniques have also been used, including 3D laser scanning and modeling, for documenting spatial deformations (see, e.g., Casciu, Centauro, and Chimenti 2000); ultrasonic pulse vibration and measurement (see, e.g., Gosálbez et al. 2006); and infrared thermography (see, e.g., Grinzato et al. 1994).
- 5 For a recent collection of papers on the problems of salt contamination of wall paintings and approaches to salts-reduction treatments, see Leitner, Laue, and Siedel 2003. For a bibliography of previous literature on the desalination of porous materials, see Vergès-Belmin 2003.
- 6 The presses had a lightweight wood backing with polyurethane foam padding to provide firm but cushioned support to grouted areas of plaster. Over the foam padding were placed two layers of absorbent tissue, manufactured from paper-pulp fibers bonded to nonwoven polypropylene fabric (Kimberley Clark Wypall X60°). The absorbent tissue nearest the back of the press was also impregnated with dried, local riverbed mud, which acted as an additional means of holding absorbed moisture. On top of the tissue layers, lens tissue was incorporated as an intervention layer at the interface with the wall painting. Presses were applied against the plaster with the aid of custom-made press guns sprung from adjustable frames attached to the scaffolding.
- 7 During aqueous extraction of salts from a wall painting, equilibrium is reached between the concentration in the wall and that in the applied absorbent material. At this point, the applied absorbent will not absorb more salt, and backward diffusion into the plaster may occur. For these reasons, effective salt reduction is usually a repeated action. For fuller discussion, see Grüner and Grassegger 1993.
- 8 Since salt investigations indicated that sodium chloride is the major salt species present in cave 85, monitoring of salt levels in the absorbent layers used in the presses, and in the original plaster before and after treatment, was carried out with a chloride ion electrode on aqueous extracts. For a fuller discussion of the salt contamination in cave 85, see Agnew, Maekawa, and Shuya Wei, this volume.
- 9 Effective reduction of salts from a porous structure presumes that there is capillary continuity. Since wall paintings are typically composed of multiple layers, breaks between these strata are not uncommon, and disruptions occur in the capillary pore structure. During salts reduction, salt may crystallize at these interior breaks, resulting in salt concentrations at key interfaces of the wall painting. For a fuller discussion of the redistribution of salts, see Tinzl 1994: 68; Cather 2003.
- 10 The ultrasonic humidifier was a Preservation Pencil®, and the mist was heated to 50°C. The absorbent tissue wipes (paper-pulp fibers bonded to nonwoven polypropylene fabric) were manufactured by Kimberley Clark (Kimberley Clark KayDry EX-L®).
- 11 The earthen repair mixture was composed of 36% sand and 64% riverbed mud, with added straw. See also note 3 above.
- 12 See Schilling et al., this volume, for analysis of the animal glue sealant. Gelatin was used as a localized paint fixative or plaster consolidant in concentrations varying from 1 to 2%, depending on variable treatment circumstances and conditions.
- 13 For full details, see the Mogao Cave 85 Project Report, forthcoming on the Getty Web site (www.getty.edu).

- 14 Most of the conservation literature on grouts is primarily concerned with its laboratory-based development and testing (see, e.g., Ferragni et al. 1984; Botticelli et al. 1986; Baglioni et al. 1997; Barcellona et al. 1993). A significant precedent for the cave 85 project was the collaborative project of the Courtauld Institute of Art (University of London) and the Valletta Rehabilitation Project to conserve the late-sixteenth-century frescoes by Filippo Paladini in the Chapel of the Grandmaster, Magisterial Palace, Valletta (Malta), undertaken from 1998 to 2004. Based on grouting research at the Courtauld Institute (Griffin 1999, 2004), the Valletta project also focused on the development of a compatible grout (lime-based), followed by its large-scale implementation.

References

- Baglioni, P., L. Dei, F. Piqué, G. Sarti, and E. Ferroni. 1997. New autogenous lime-based grouts used in the conservation of lime-based wall paintings. *Studies in Conservation* 42 (1): 43–54.
- Barcellona, S., U. Santamaria, E. Borrelli, and M. Laurenzi Tabasso. 1993. Evaluation of injection grouting for structural strengthening of ancient buildings. In *Conservation of Stone and Other Materials: Proceedings of the International RILEM/ UNESCO Congress "Conservation of Stone and Other Materials: Research-Industry-Media" Held at UNESCO Headquarters, Paris, June 29–July 1, 1993*, 1st ed., ed. M.-J. Thiel, 637–43. RILEM Proceedings, no. 21. London: E & FN Spon.
- Botticelli, G., M. Matteini, A. Moles, and L. Giancarlo. 1986. A mineral expansive material for readhesion operations on mural paintings. In *Scientific Methodologies Applied to Works of Art: Proceedings of the Symposium, Florence, Italy, 2–5 May 1984*, ed. P. L. Parrini, 177–79, 241. Milan: Montedison progetto cultura.
- Casciu, S., G. A. Centauro, and M. Chimenti. 2000. The archival documentation system: The computerized heart of the restored *History of the True Cross* by Piero della Francesca. In *GraDoc: Graphic Documentation Systems in Mural Painting Conservation: Research Seminar, Rome, 16–20 November 1999*, ed. W. Schmid, 208–19. Rome: ICCROM.
- Cather, S. 2003. Aqueous extraction of soluble salts from porous materials: Alternatives and contra-indications. In *Mauersalze und Architekturoberflächen*, ed. H. Leitner, S. Laue, and H. Siedel, 167–72. Dresden: Hochschule für Bildende Künste.
- Ferragni, D., M. Forti, J. Malliet, P. Mora, J. M. Teutonico, and G. Torraca. 1984. Injection grouting of mural paintings and mosaics. In *Adhesives and Consolidants: Preprints of the Contributions to the Paris Congress, 2–8 September 1984*, ed. N. S. Brommelle, 110–16. London: International Institute for Conservation of Historic and Artistic Works.
- Gosálbez, J., A. Salazar, I. Bosch, R. Miralles, and L. Vergara. 2006. Application of ultrasonic nondestructive testing to the diagnosis of consolidation of a restored dome. *Materials Evaluation* 64 (5): 492–97.
- Griffin, I. 1999. Earthen grouts in wall painting conservation: An investigation of their working properties and performance characteristics. M.A. thesis, Courtauld Institute of Art.
- . 2004. Pozzolanas as additives for grouts: An investigation of their working properties and performance characteristics. *Studies in Conservation* 49 (1): 23–34.
- Grinzato, E., P. Bison, S. Marinetti, and V. Vavilov. 1994. Nondestructive evaluation of delaminations in fresco plaster using transient infrared thermography. *Research in Nondestructive Evaluation: A Journal of the American Society for Nondestructive Testing* 5 (4): 257–74.
- Grüner, F., and G. Grassegger. 1993. Der Einfluß der Kompressentrocknung auf den Entsalzungseffekt: Laborversuche zur quantitativen Erfassung. *WTA Berichte* 9: 75–86.
- Leitner, H., S. Laue, and H. Siedel, eds. 2003. *Mauersalze und Architekturoberflächen*. Dresden: Hochschule für Bildende Künste.
- Sawdy, A. 2003. The role of environmental control for reducing the rate of salt damage in wall paintings. In *Conserving the Painted Past: Developing Approaches to Wall Painting Conservation: Post-Prints of a Conference Organised by English Heritage, London, 2–4 December, 1999*, ed. R. Gowing and A. Heritage, 95–109. London: Earthscan/James & James.
- Tinzl, C. 1994. Removal of salts from lime plaster by means of poulticing. Diploma thesis, Courtauld Institute of Art.
- Vergès-Belmin, V. 2003. Desalination of porous building materials: A review. In *Mauersalze und Architekturoberflächen*, ed. H. Leitner, S. Laue, and H. Siedel, 121–37. Dresden: Hochschule für Bildende Künste.

Materials and Suppliers

Absorbent tissue and wipes:

Kimberley Clark Wypall X60®
Kimberley Clark KayDry EX-L®

Ultrasonic humidifier:

Preservation Pencil®
Preservation Equipment Ltd.
Vinces Road
Norfolk IP22 4HQ, England

A Rapid Means of Measuring Residual Salt after Grouting and Poulticing Wall Paintings

Chen Gangquan, Michael R. Schilling, Li Yanfei, Joy Mazurek, Yu Zhongren, and Lisa Shekede

Abstract: A nondestructive, semiquantitative spot test method was developed to determine chloride ion concentration on the surface of wall paintings in cave 85. Water in the grout used in the conservation project in the cave brought salts to the surface. The poulticing technique used with grouting reduced the surface salts and prevented crystallization, but a test was needed to provide a quick, reproducible method of determining residual salt on areas that had been grouted. The technique also had application in evaluating the effectiveness of the Preservation Pencil in further reducing surface salt in the same areas. The test comprises application of wet paper to the surface, followed by measurement of the chloride ion absorbed by the paper using a specific ion electrode. As a means of systematically mapping chloride, the technique has application both prior to and after interventions that mobilize soluble salts.

Hygroscopic Salt Redistribution and Removal in Poulticing

Localized separation of the painted plaster layer from the rock wall in cave 85, a condition classified as detachment, was a serious problem that required conservation intervention. Detachment was remedied by injecting grouting material into the void space between the plaster and the rock wall to readhere the plaster (Li Zuixiong 2005). Though effective, grouting had one significant drawback: mobilization and subsequent redistribution of hygroscopic salts, which consist largely of sodium chloride, that were present up to 6 percent by weight in the plaster layer (Li Zuixiong 2005; Schilling et al., this volume).

To address this concern, a poulticing procedure was developed that reduced the salt content of the paint and

plaster layers (Li Zuixiong 2005; Rickerby et al., “Testing and Development,” this volume). After poulticing, the salt content in the wall paintings was further reduced through the use of a Preservation Pencil (fig. 1), an ultrasonic humidifier manufactured by Preservation Equipment Ltd., England. By misting the wall paintings with water vapor directed from the nozzle of the device and blotting the paintings immediately with cotton paper, a portion of the salts could be removed safely from the painted surfaces (fig. 2).

The overall extent of reduction in the salt content of the plaster surface by poulticing could be estimated by a spot test developed specifically for the cave 85 project. In the



FIGURE 1 The Preservation Pencil.



FIGURE 2 Salts being removed with the Preservation Pencil.

spot test method, a **prewettted and standardized size of absorbent chromatography paper** was applied to the surface of the wall painting for a specified amount of time, then removed and immersed in deionized water. The concentration of chloride ion in the water was then measured by a chloride-specific ion electrode.

Spot Test Procedure

A single layer of chromatography paper (Grade 81-24) was cut into strips 1 centimeter by 2 centimeters (approximately 40 mg in weight and 1 mm in thickness). The paper strip was placed into distilled water using a fine-point tweezers and removed after five seconds. Excess water was removed by touching the paper strip to the container wall. The average weight of water in the saturated paper was 160 milligrams \pm 2 percent relative standard deviation (based on twenty-seven replicate measurements). The wetted strip was applied to the surface of a prefabricated clay coupon that contained 6 percent by weight of salt (Chen Gangquan et al. 2005), carefully avoiding pockets of air. It was determined that the paper should be removed after forty seconds, by which time a maximum of 60 milligrams of water will have entered the plaster coupon and penetrated to a depth of 2 millimeters. The paper strips were then put into plastic tubes that contained exactly 2 milliliters of deionized water, and after six hours the chloride ion concentration was measured using a chloride-specific ion electrode (Thermo Orion Model 290 meter and



FIGURE 3 Prewettted paper strip applied to a wall painting in cave 85.

Thermo Orion 9617BN chloride electrode, Orion Research Company, Boston, MA).

Calibration of the Spot Test Method

Developing a means to calibrate the spot test procedure was one of the most important aspects of this research. Plaster coupons fabricated with known quantities of salt would seem to be ideal candidates for calibration standards, although their porosity, texture, and water-uptake behavior do not match the properties of the original plaster layers in cave 85. Instead, the wealth of information obtained from the plaster microcore survey (Schilling et al., this volume) made it possible to calibrate the spot test with respect to the actual in situ salt concentrations. The spot test method was used on the west wall of cave 85 in areas where the painted surface had already been lost but where the integrity of the plaster surface was intact (fig. 3). After completion of the spot test measurements, **plaster microcore samples were taken adjacent to the spot test area in locations where no paint was present. The plaster microcores were approximately 5 millimeters in diameter and 2 millimeters deep.**

Based on the test results, a **calibration curve was constructed** by plotting the chloride ion concentration from the spot tests versus the plaster microcore samples (fig. 4). The relationship can be expressed by the equation

$$Y = 6.27X + 0.1005,$$

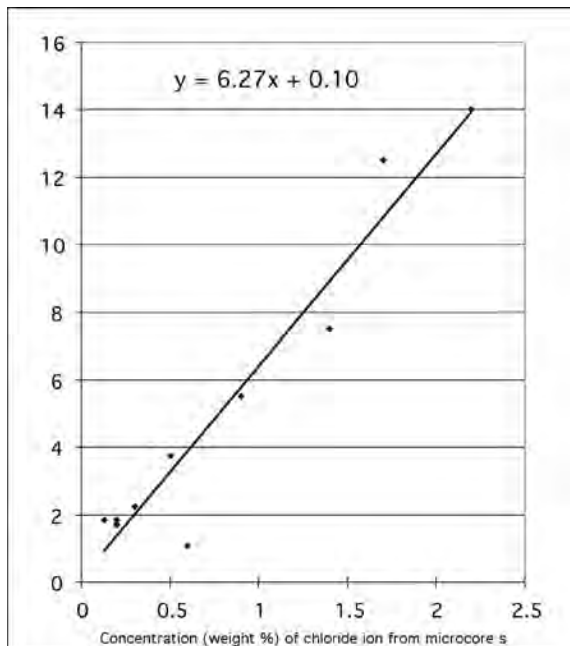

FIGURE 4 Relationship between chloride ion concentration in spot tests and plaster microcores.

where *Y* is the chloride ion concentration in parts per million (ppm) from the spot tests, and *X* is the chloride ion concentration in weight percent from the plaster microcores. A linear curve fitted to the data had a correlation coefficient, *r*, of 0.9633. Thus, with this equation, the approximate chloride ion concentration in the plaster layer of the wall paintings in cave 85 may be measured using the spot test procedure.

Application of the Spot Test Method to Grouted Plaster in Cave 85

The spot test method was used to assess the results of poulticing on the west wall in cave 85. Tables 1–4 list chloride ion concentrations for various types of plaster: untreated (ungrouted) plaster (table 1), grouted plaster poulticed with X60 cotton paper (table 2), grouted plaster poulticed with X60 cotton paper and treated with the Preservation Pencil (table 3), and ungrouted plaster treated with the Preservation Pencil (table 4). Table 5 summarizes the results from the previous tables, and figure 5 illustrates the mean data from table 5. The test results indicate that after grouting the moisture from the grout redistributes hygroscopic salts within the plaster layer and enriches them at the surface.

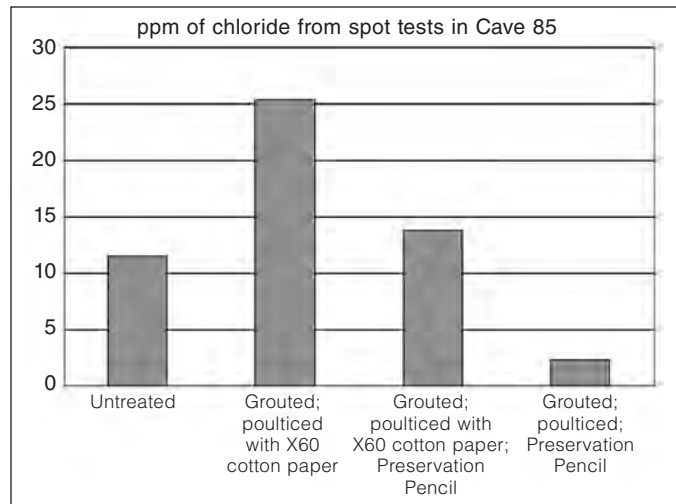

FIGURE 5 Summary of results from tables 1–5.

Table 1 Spot Test Results at UngROUTED Areas

#	Sample Location	ppm Cl ⁻
1	60cm from south wall, 138cm from floor	19
2	105cm from south wall, 200cm from floor	34
3	144cm from south wall, 200cm from floor	31
4	206cm from south wall, 200cm from floor	8
5	210cm from south wall, 180cm from floor	8
6	278cm from south wall, 168cm from floor	7
7	286cm from south wall, 200cm from floor	5
8	330cm from south wall, 198cm from floor	19
9	360cm from south wall, 182cm from floor	11
10	450cm from south wall, 140cm from floor	8
11	460cm from south wall, 170cm from floor	7
12	375cm from north wall, 150cm from floor	6
13	340cm from north wall, 200cm from floor	10
14	250cm from north wall, 135cm from floor	7
15	280cm from north wall, 200cm from floor	9
16	200cm from north wall, 123cm from floor	10
17	190cm from north wall, 202cm from floor	17
18	330cm from north wall, 175cm from upper frame	8
19	335cm from north wall, 165cm from upper frame	8
20	245cm from north wall, 150cm from upper frame	8
21	240cm from north wall, 148cm from upper frame	6
22	45cm from south wall, 75cm from top of west wall	8
		11.5 (mean)

Table 2 Spot Test Results at Grouted Areas Poulitced with X60 Cotton Paper

#	Sample Location	ppm Cl ⁻
23	70cm from south wall, 200cm from floor	8
24	115cm from south wall, 125cm from floor	5
25	148cm from south wall, 175cm from floor	17
26	210cm from south wall, 120cm from floor	25
27	230cm from south wall, 190cm from floor	47
28	270cm from south wall, 130cm from floor	5
29	300cm from south wall, 198cm from floor	166
30	330cm from south wall, 135cm from floor	6
31	355cm from south wall, 200cm from floor	3
32	355cm from south wall, 145cm from floor	7
33	470cm from south wall, 180cm from floor	5
34	505cm from south wall, 185cm from floor	8
35	545cm from south wall, 190cm from floor	10
36	320cm from north wall, 130cm from floor	21
37	250cm from north wall, 200cm from floor	10
38	240cm from north wall, 163cm from floor	10
39	220cm from north wall, 168cm from floor	11
40	160cm from north wall, 146cm from floor	12
41	160cm from north wall, 190cm from floor	7
42	85cm from north wall, 145cm from floor	10
43	88cm from north wall, 200cm from floor	8
44	45cm from north wall, 180cm from floor	14
45	10cm from south wall, 155cm from upper frame	143
46	45cm from south wall, 176cm from upper frame	49
		25.3 (mean)

Table 3 Spot Test Results at Grouted Areas Poulitced with X60 Cotton Paper and Treated with the Preservation Pencil

#	Sample Location	ppm Cl ⁻
47	210cm from south wall, 165cm from upper frame	12
48	165cm from south wall, 135cm from upper frame	19
49	210cm from south wall, 112cm from upper frame	9
50	235cm from south wall, 120cm from upper frame	68
51	295cm from south wall, 130cm from upper frame	8
52	325cm from south wall, 60cm from upper frame	7
53	380cm from south wall, 35cm from upper frame	9
54	400cm from south wall, 37cm from upper frame	4
55	420cm from south wall, 26cm from upper frame	5
56	435cm from south wall, 12cm from upper frame	5
57	395cm from north wall, 120cm from upper frame	7
58	340cm from north wall, 78cm from upper frame	5
59	310cm from north wall, 145cm from upper frame	5
60	250cm from north wall, 124cm from upper frame	10
61	225cm from north wall, 45cm from upper frame	8
62	235cm from north wall, 170cm from upper frame	10
63	164cm from north wall, 135cm from upper frame	10
64	145cm from north wall, 30cm from upper frame	42
65	88cm from north wall, 126cm from upper frame	42
66	165cm from south wall, 20cm from top of west wall	7
67	220cm from south wall, 22cm from top of west wall	13
68	175cm from south wall, 56cm from top of west wall	5
69	230cm from south wall, 90cm from top of west wall	5
		13.7 (mean)

Table 4 Spot Test Results at UngROUTED Areas Treated with the Preservation Pencil

#	Sample Location	ppm Cl ⁻
70	90cm from south wall, 40cm from upper frame	12
71	130cm from south wall, 48cm from upper frame	3
72	210cm from south wall, 65cm from upper frame	2
73	245cm from south wall, 75cm from upper frame	2
74	270cm from south wall, 80cm from upper frame	2
75	320cm from south wall, 76cm from upper frame	2
76	430cm from north wall, 50cm from upper frame	2
77	405cm from north wall, 80cm from upper frame	None
78	300cm from north wall, 35cm from upper frame	1
79	300cm from north wall, 70cm from ceiling	1
80	415cm from south wall, 60cm from ceiling	2
81	378cm from south wall, 70cm from ceiling	1
82	390cm from south wall, 115cm from ceiling	5
83	430cm from south wall, 125cm from ceiling	1
84	410cm from north wall, 120cm from ceiling	2
85	375cm from north wall, 130cm from ceiling	1
86	156cm from north wall, 95cm from ceiling	1
87	132cm from north wall, 98cm from ceiling	2
		2.3 (mean)

Poulticing with X60 cotton paper immediately after grouting reduces the salt content somewhat, although after poulticing the salt content remains roughly twice that of ungrouted areas. Treatment with the Preservation Pencil reduces the chloride content by 10 ppm, which is equivalent to 1.6 percent of chloride ion in the plaster layer, or 80 percent of the salt content of ungrouted plaster. Thus the Preservation Pencil was an integral part of the salt reduction process.

One limitation of the spot test method is that extremely friable plasters cannot be handled safely with the adsorbent paper. Moreover, moisture from the prewetted paper strips will carry salts deeper into the plaster layer, thereby reducing their concentration at the surface. However, if the process is standardized and conducted reproducibly, the calibration curve adequately compensates for many procedural variables.

Table 5 Summary and Results of Spot Tests in Cave 85: Chloride Ion Concentrations (in ppm) from Tables 1–4

	Untreated	Grouted & Poulticed, No Pencil	Grouted & Poulticed, with Pencil	UngROUTED, with Pencil
	19	8	12	12
	34	5	19	3
	31	17	9	2
	8	25	68	2
	8	47	8	2
	7	5	7	2
	5	166	9	2
	19	6	4	Not detected
	11	3	5	1
	8	7	5	1
	7	5	7	2
	6	8	5	1
	10	10	5	5
	7	21	10	1
	9	10	8	2
	10	10	10	1
	17	11	10	1
	8	12	42	2
	8	7	42	
	8	10	7	
	6	8	13	
	8	14	5	
		143	5	
		49		
Statistics				
<i>n</i>	22	24	23	18
Mean	11.5	25.3	13.7	2.3
% RSD	8	42	16	3

Conclusion

Hygroscopic salts present in painted earthen plasters are redistributed by aqueous grouting mixtures, which enriches them at the plaster surface and enhances the potential for damage. Poulticing with paper, followed by treatment with the Preservation Pencil, greatly reduced the salt content at the plaster surface, as demonstrated by measurement data from a chloride ion spot test developed in the cave 85 project. The spot test was shown to be a rapid, inexpensive, and minimally invasive means of surveying the hygroscopic salt content of earthen renders.

References

- Chen Gangquan, Su Bomin, Zhao Linyi, Yu Zongren, Li Zuixiong, and N. Agnew. 2005. [Wall painting disruption simulation experiments in cave 85 at the Mogao Grottoes]. *Dunhuang Research* 4: 62–64.
- Li Zuixiong. 2005. *Si chou zhi lu shi ku bi hua cai su bao hu = Conservation of Grotto Wall Paintings and Sculptures on the Silk Road*. Beijing: Ke xue chu ban she.

The Information Management System for the Cave 85 Project

Lorinda Wong, Francesca Piqué, Wang Xiaowei, and Xu Shuqing

Abstract: *This paper describes the information management system for the conservation of wall paintings project in cave 85. The information management system was created as a dynamic database of all information generated from the start of the project in 1997 through to its completion in 2005. Given the complexities of the deterioration mechanisms found in cave 85, the project required an interdisciplinary approach with joint investigation by conservation, documentation, analytical, and environmental teams. With a project of this scope, scale, and duration, new data were constantly being generated and existing data were continuously evolving. Over the course of the eight-year project each team produced significant quantities of data. The problem of managing the continuous flow of new information and maintaining control over the existing body of data, to allow access of information between project teams, was solved by establishing a data protocol system. This was a simple system for receiving, storing, and retrieving information that was managed by an information manager through whom all information flowed. In addition to organizing and storing information, the information management system facilitated the integration and synthesis of information between project teams. In particular, the integration of environmental, analytical, and conservation data was essential in establishing the deterioration mechanisms of the wall paintings that were critical for designing effective and appropriate treatment interventions and preventive conservation measures. This enabled informed decision making to guide the scope and management of the project. Lessons gained from the management of this large body of data have had wider application for the conservation of other caves at the Mogao Grottoes and at similar projects of this scale.*

Information management is integral to every aspect of the conservation process (see Piqué, Wong, and Su Bomin, this volume). Information management for the cave 85 project encompasses the collection, organization, storage, retrieval, integration, manipulation, and presentation of data. The eight-year project involved specialists from many fields: wall painting conservators, documentation specialists, photographers, historians, analytical chemists, and environmental scientists, among others. Copious information was generated in each of these areas.

With so much information being generated and multiple users involved on several continents and with data being produced in Chinese and English, the challenge was to establish a system that would work across disciplines while facilitating access by team members. Information management for the cave 85 project was therefore not a static endeavor focused only on organizing and storing information; rather it facilitated the integration, analysis, and use of data between teams essential in making educated decisions on how to preserve this important site and to move the project forward.

Problems

The cave 85 project data in electronic form consist of over 50 gigabytes of text, data, photographic, and graphic files. The files are in a number of different formats, including Microsoft® Word, Excel, and PowerPoint documents, Autodesk® AutoCAD drawings, Adobe® InDesign, Photoshop and Illustrator files, and thousands of digital images in RAW, TIFF, and JPEG format. The amount of information has steadily increased throughout the project, with a dramatic rise starting in 2003 with the transition from film to digital photography.

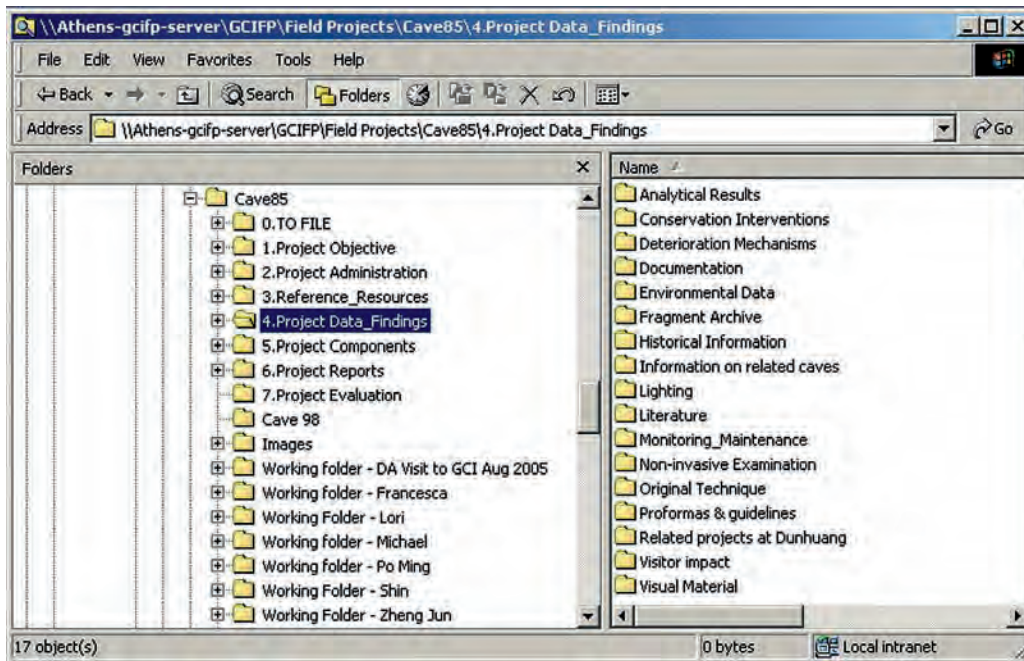

FIGURE 1 File organizational structure for the cave 85 project.

In a multiyear project of this nature, with many team members working in different locations, it became increasingly difficult and time-consuming to locate and retrieve relevant files. The lack of standardized file naming exacerbated the problem, as did the lack of centralized storage of files and an agreed-on file organizational structure. Files were often kept on personal computers, inaccessible to other team members. Multiple versions of a single file were generated without indication of when it was modified or by whom. These circumstances combined with inadequate communication between project team members led to wasted time and inefficiency.

Solutions

The decision to focus attention on information management came midway through the project. A protocol for receiving, storing, and sharing information was established; key to its implementation was the appointment of an information manager through whom all information would flow.

For cave 85, the information manager worked with project team members on the following tasks:

- *Data collection.* Receiving and monitoring data from project team members.
- *File naming.* Naming or renaming files following an agreed-on convention (including a brief

description of the content, metadata on the author, creation date, and file type; e.g., MOG.85.S04.EW.ToolMarks.FP.d.jpg includes the following information: Mogao Grottoes, Cave 85, Spring 2004 Field Campaign, East Wall, Tool Marks, Francesca Piqué, Digital image capture, jpg format).

- *Storage.* Storing files in their appropriate place on a shared folder and not on personal computers (the shared folder is a secure, networked location that allows access to all project members and is regularly backed up) following an agreed-on file organizational structure (fig. 1).
- *Data sharing.* Communicating receipt and availability of project information to team members, including the creation of a parallel database and the identification of an information manager at the Dunhuang Academy to allow for the exchange of critical documents.
- *Retrieval.* Locating files and helping direct team members to relevant information.
- *Maintenance.* Maintaining and reorganizing the shared folder and keeping information current.

The system required participation of the team and continuous attention and maintenance and relied on human accuracy.

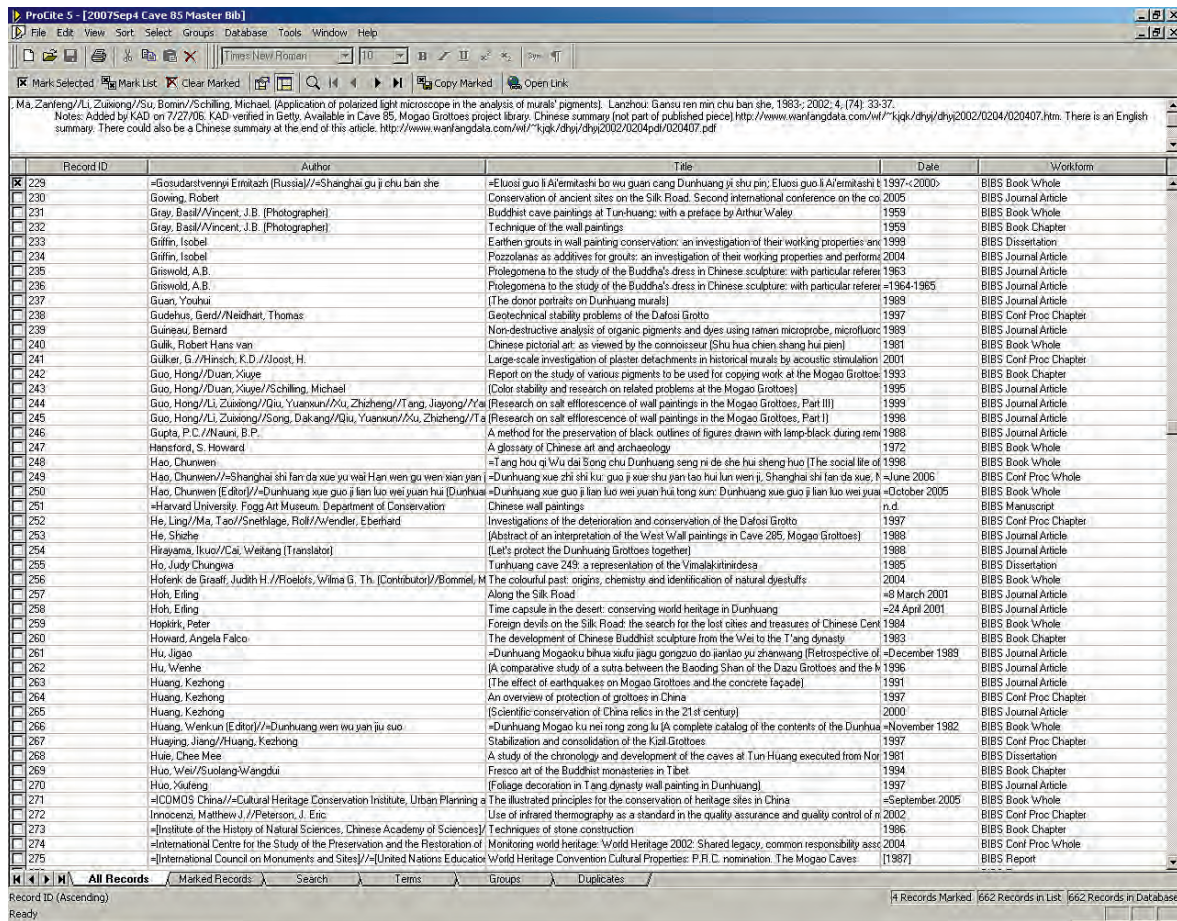

FIGURE 2 Project bibliography in ProCite® (a product of the Thomson Corporation).

Types of Data

As part of the information gathering, assessment, testing and development, implementation, and monitoring and maintenance phases of the project (see Piqué et al., this volume), many types of information were collected and created. The initial information-gathering phase included collection of written and oral sources on the historical context of the commissioning and construction of the cave in the late Tang dynasty and art historical and iconographic research of its wall paintings and sculptures. The history of interventions was also undertaken by consulting treatment reports and interviewing Dunhuang Academy conservators. This led to the creation of a bibliography specific to cave 85 and relevant to wall paintings on earthen supports generally. As the project progressed, the list of references grew; the project bibli-

ography now contains more than seven hundred records in hard copy and electronic form (fig. 2).

Visual resources were also collected to help reconstruct the physical history of cave 85, including the earliest known photograph of the cave, taken by the Russian expedition to the Mogao Grottoes in 1914 (fig. 3). Taken some fifty years before the construction of the cliff facade, the photograph shows the paintings in the antechamber exposed to the exterior and the condition of the site at that time. Photographs from explorers and travelers who visited the Mogao Grottoes in the early twentieth century have contributed significantly to understanding the history of the site, its deterioration, and whether or not deterioration was treated. This kind of information has been fundamental to understanding the processes and the causes of deterioration affecting the cave today. Photographs of the wall paintings in cave 85 taken by James Lo and Lucy Lo in 1943–44 provide an important record of the condition of the wall paintings before any modern intervention. Photographs by a young American woman, Irene Vongehr Vincent, who traveled to Dunhuang in 1948,



FIGURE 3 Earliest known photograph of cave 85, taken by the Russian expedition led by Sergei Oldenburg (1863–1934) to the Mogao Grottoes in 1914–15. Reproduced by permission of the State Hermitage Museum of Russia

also contribute to our records (Vincent 1953), in addition to the many photographs taken over the years by the Dunhuang Academy, which was established in 1944.

In addition, current photographs, including the more than five hundred (color and black-and-white) taken as part of the comprehensive documentation of the condition of the paintings at the start of the Getty Conservation Institute–Dunhuang Academy project, are also part of the database. These photographs were used as base maps for graphic condition recording of the cave. The condition was manually recorded on transparencies over the photographs and then transferred into digital format as CAD drawings (fig. 4). To supplement the condition assessment, an illustrated terminology was created to standardize communication between team members, to aid in the recording of condition, and to show the severity of conditions recorded. The glossary includes an agreed-on term and definition for each condition phenomenon (in both English and Chinese) and is illustrated with detailed photographs. The glossary helped to establish greater objectivity in a normally subjective recording process, facilitating both the recording and the subsequent interpretation of condition records. (For more information on the condition recording process in cave 85, see Xu Shuqing et al., this volume.)

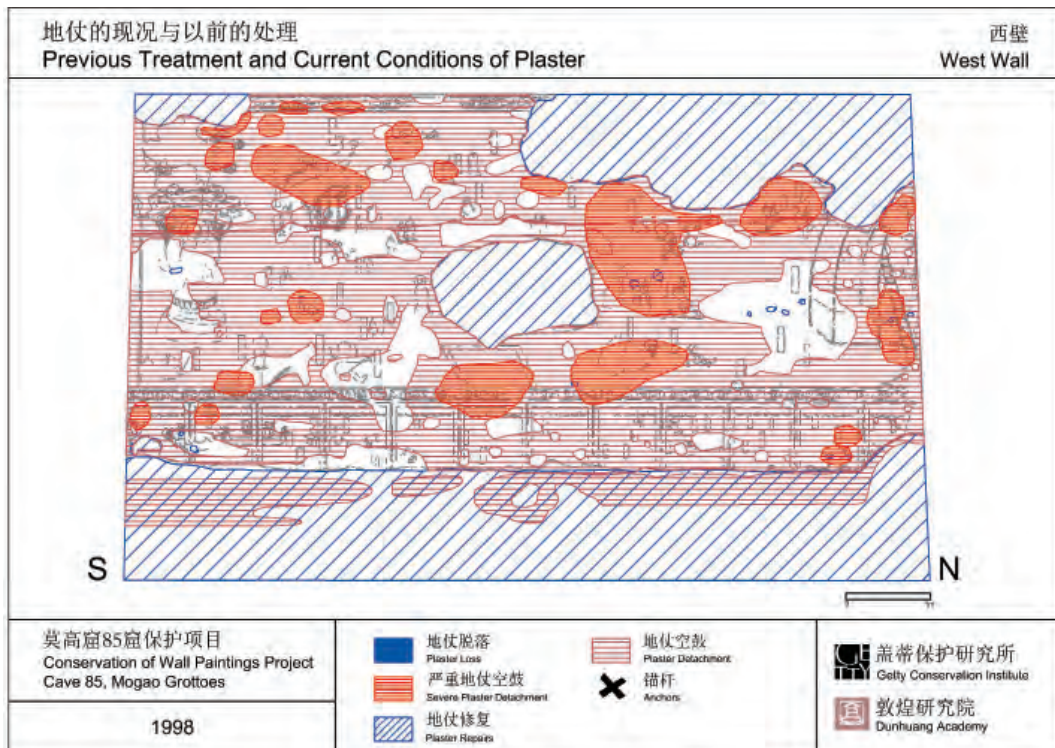

FIGURE 4 The condition of the wall paintings was recorded on transparencies laid over photographs and then transferred into digital format as CAD drawings. This image shows the west wall of the cave with areas of loss and plaster detachment graphically indicated.

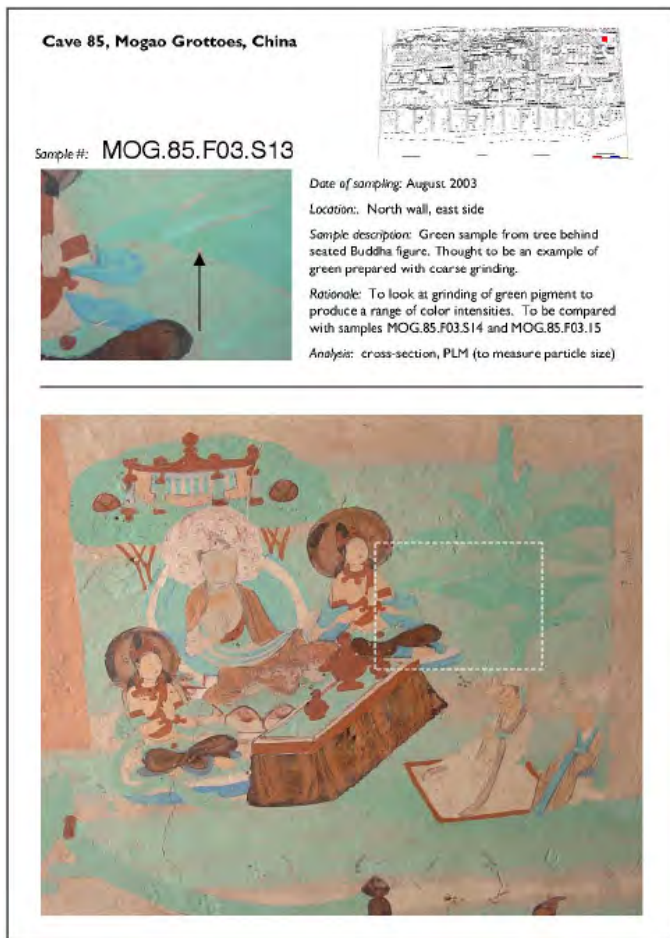

FIGURE 5 An example of the reports created for each individual sample.

Sampling was undertaken to characterize the original materials of the painting and to understand painting techniques. Each sample was documented, and analytical tests were employed depending on the particular questions to be answered. A separate report was then created for each sample (fig. 5). This included a description of the sample, its location, sampling rationale, and results of the analysis. The raw data resulting from each analysis were also archived separately to allow for future reference and study.

Environmental monitoring generated immense quantities of data, including exterior and interior conditions such as temperature and relative humidity, as well as total rainfall accumulation and rainfall intensity (see Maekawa et al., this volume). These data were systematically stored over the course of the project in collaboration with members of the environmental team.

As part of the testing and development of treatments, laboratory and in situ testing were documented, including the research and testing of grout formulations for use in treating detached painted plaster. Some eighty different grout formulations were subjected to rigorous testing (see Rickerby et al., on development and testing, this volume). Following testing, treatments were implemented and documented using graphic documentation and photography. For future monitoring, areas treated were identified and recorded to create baseline documentation.

Integration, Manipulation, and Presentation of Information

Given the complexity of the deterioration mechanisms, information from individual investigations alone does not always provide a complete understanding. There is a need to integrate information with related investigations and to visually display the data in a clear manner. Understanding the deterioration of the paintings involved integration and visual presentation of information from different disciplines.

Preliminary investigations identified soluble salts as the primary cause of both surface and subsurface deterioration. A salt survey undertaken to confirm this hypothesis included the sampling of forty-seven microcores, each taken at four or five incremental depths into the upper 10 millimeters of the plaster, resulting in nearly two hundred samples (fig. 6). The incremental depths of the samples correspond



FIGURE 6 Plaster microcores being sampled as part of a comprehensive salt survey. Each core was taken at four or five incremental depths into the upper 10 millimeters of the wall where paint has been lost. The samples were analyzed to identify ions of soluble salts present and their topographic and stratigraphic distribution throughout the cave.

to the painting technique and stratigraphy. The microcores were then analyzed to identify ions of soluble salts present and their topographic and stratigraphic distribution.

The data were visually presented to correlate analytical with conservation data. The location of the microcores was superimposed over the CAD condition drawings. Each microcore has a corresponding data chart showing the main soluble ions divided by incremental depth. This type of plotting was done for all areas and clearly shows the enrichment

of soluble salts toward the rear (west) end of the cave (fig. 7a), by comparison with the east end (fig. 7b). It establishes a direct correlation between the high salt content of the plaster and the poor condition of the wall paintings and identifies the constraints and limitations of undertaking treatment in these problem areas. Presenting the data visually helps to interpret the vast amount of tabulated data generated as part of the microcore sampling (table 1).

Table 1 Results of the Salt Survey in Cave 85 Showing Soluble Ion Content of the Plaster Microcores

	A	B	C	D	G	H	I	J	K	L	M	N	O	P	Q	R
1																
2																
3					Milliequivalents per 100 grams of plaster											
4		Sample Location	D	Sample depth, mm	Cl ⁻	NO ₃ ⁻	SO ₄ ²⁻	Na ⁺	K ⁺	Mg ²⁺	Ca ²⁺	Total anions	Total cations			Ratio of Total Anions to Total Cations
5		West wall	15A	0-2mm	20.9	1.02	18.62	39.37	1.18	0.80	6.85	40	48			84
6		West wall	15B	2-5	24.5	1.14	14.66	44.22	1.04	0.44	2.38	40	48			84
7		West wall	15C	5-7	24.3	1.27	18.27	46.63	1.07	0.49	2.84	44	51			86
8		West wall	15D	7-10	35.6	1.18	13.49	52.14	1.13	0.51	2.35	50	56			90
9																
10		West wall	16A	0-2	9.9	1.16	30.43	24.02	0.85	0.94	19.10	41	45			92
11		West wall	16B	2-5	38.2	1.82	17.67	57.18	1.10	0.79	5.49	58	65			89
12		West wall	16C	5-7	70.8	1.71	10.84	81.88	1.05	0.60	2.89	83	86			96
13		West wall	16D	7-10	34.3	1.86	11.17	50.61	0.97	0.44	2.71	47	55			87
14																
15		West wall	17A	0-2	64.9	1.21	22.69	82.21	1.10	0.74	7.14	89	91			97
16		West wall	17B	2-5	25.7	0.92	16.54	45.61	0.96	0.41	3.30	43	50			86
17		West wall	17C	5-7	53.1	1.06	13.87	69.08	1.02	0.33	2.39	68	73			93
18		West wall	17D	7-10	49.2	1.30	13.29	65.57	1.20	0.43	2.46	64	70			92
19																
20		West wall	18A	0-2	44.4	1.07	13.32	51.96	0.95	1.44	8.13	59	62			94
21		West wall	18B	2-5	24.4	1.46	11.97	37.40	0.90	0.88	5.40	38	45			85
22		West wall	18C	5-7	51.9	2.51	7.71	62.42	0.94	0.72	2.75	62	67			93
23		West wall	18D	7-10	57.7	2.39	6.38	69.05	0.88	0.59	2.00	66	73			92
24																
25		West wall	19A	0-2	6.2	0.62	19.25	17.42	0.58	0.65	10.93	26	30			88
26		West wall	19B	2-5	33.1	0.97	15.25	49.06	0.86	0.74	6.13	49	57			87
27		West wall	19C	5-7	38.2	1.28	10.39	53.84	0.87	0.34	2.20	50	57			87
28		West wall	19D	7-10	34.7	1.11	7.90	48.85	0.79	0.24	1.49	44	51			85
29																
30		West wall	20A	0-2	10.8	0.93	17.36	20.78	0.67	0.86	10.65	29	33			88
31		West wall	20B	2-5	55.1	1.52	8.82	64.54	0.86	0.70	3.50	65	70			94
32		West wall	20C	5-7	39.1	1.48	5.07	50.10	0.81	0.42	1.58	46	53			86
33		West wall	20D	7-10	34.3	1.82	7.80	46.05	0.86	0.57	2.29	44	50			88
34																
35		West wall	21A	0-2	37.1	1.30	33.34	59.82	1.19	0.84	11.77	72	74			97
36		West wall	21B	2-5	20.6	1.22	10.77	37.44	0.89	0.28	1.90	33	41			81
37		West wall	21C	5-7	48.1	1.11	13.45	62.34	0.92	0.44	3.36	63	67			93
38		West wall	21D	7-10	44.8	1.74	30.58	62.72	1.22	0.89	14.17	77	79			98
39																
40		West wall	22A	0-2	6.4	0.67	22.62	19.30	0.69	0.67	12.23	30	33			90
41		West wall	22B	2-5	49.2	1.43	20.38	67.36	0.96	0.83	7.03	71	76			93
42		West wall	22C	5-7	62.6	1.41	15.05	76.37	0.99	0.70	4.86	79	83			95
43		West wall	22D	7-10	31.3	1.47	10.19	46.03	0.94	0.34	2.34	43	50			87
44																
45		West wall	23A	0-2	4.7	0.41	10.67	12.33	0.46	0.38	6.61	16	20			80
46		West wall	23B	2-5	22.5	0.91	10.22	37.93	0.71	0.27	2.14	34	41			82
47		West wall	23C	5-7	34.5	0.83	7.79	47.51	0.67	0.18	1.22	43	50			87
48		West wall	23D	7-10	22.0	0.91	7.22	36.36	0.68	0.20	1.16	30	38			78
49																
50		West wall	24A	0-2	4.2	0.45	33.61	10.22	0.87	0.97	27.47	38	40			97
51		West wall	24B	2-5	60.0	1.08	23.43	68.62	1.44	1.49	14.34	85	86			98
52		West wall	24C	5-7	43.3	1.57	16.66	54.64	1.84	1.26	8.00	62	66			94
53		West wall	24D	7-10	32.5	1.54	15.70	45.10	1.77	1.18	7.97	50	56			89

FIGURE 7a The data from each microcore was charted and super-imposed over the CAD condition drawings. This type of plotting helped to visualize the enrichment of salts toward the rear (west) end of the cave and established a direct correlation between salt content of the plaster and deterioration of the wall paintings. This image shows the west wall with high soluble ion content.

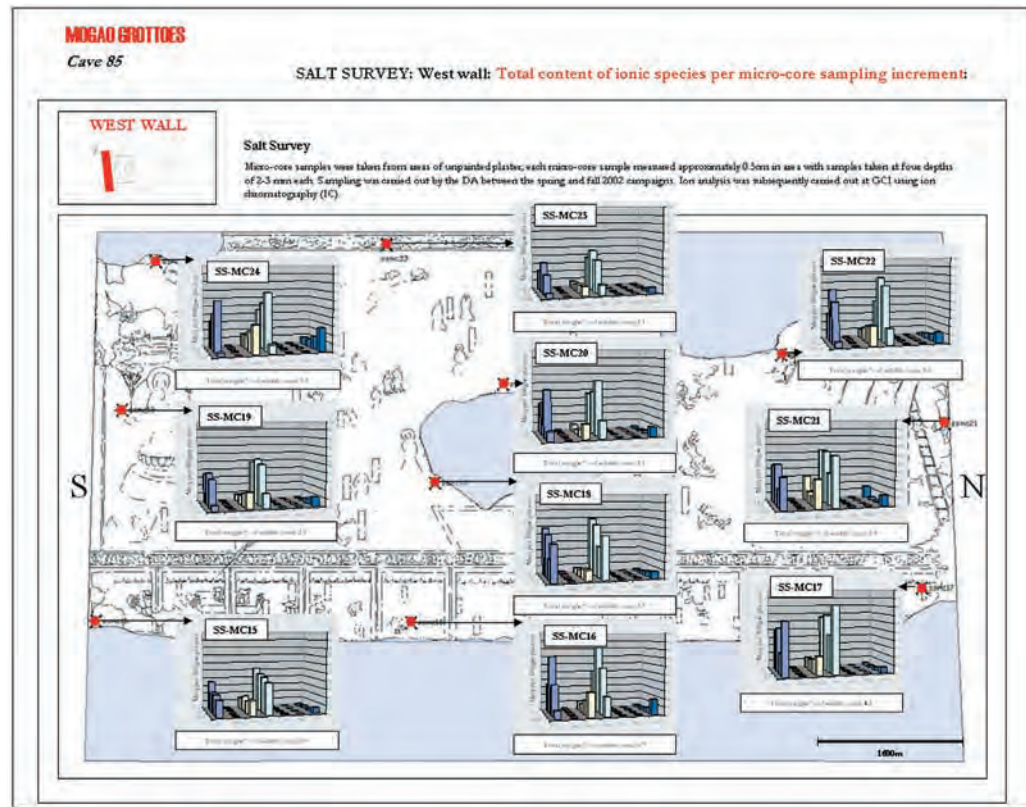
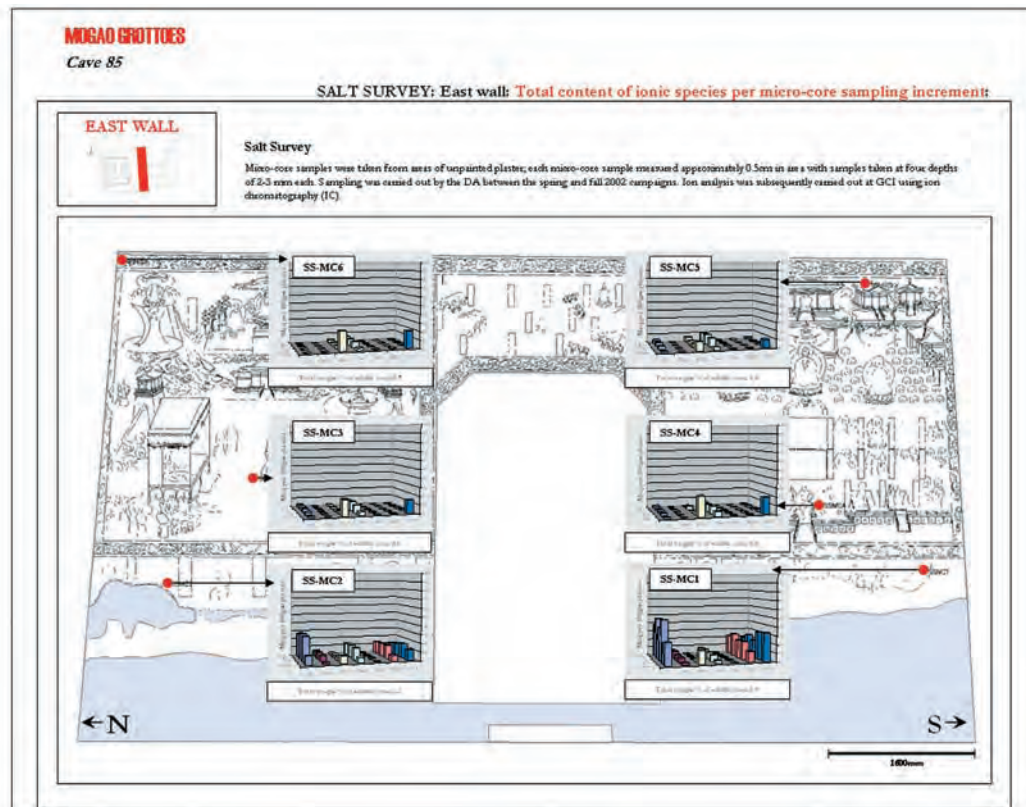

FIGURE 7b Results of the salt survey on the east wall. The soluble ion content of microcores sampled on this wall is significantly lower than that of microcores analyzed from the west wall, and the condition is significantly better than that of the west wall.



Conclusion

The cave 85 project is an example of the management challenges created by a large body of information during a complex, multiyear, interdisciplinary project involving a sizable team. The project overcame these challenges through the establishment of an information management system, the appointment of an information manager responsible for the integration of data from different investigations, and the commitment of the project team. The project database is shared between the two partner organizations. The experience gained from the management of this large body of data has had wider application for the conservation of other caves at the Mogao Grottoes and at similar projects of this scale in China.

Acknowledgments

The authors wish to express their gratitude to the members of the cave 85 project team for diligently and patiently agreeing to cooperate with the information management system. Without this level of commitment by the entire project team, the information management system would not have been possible.

References

- Gosudarstvennyi Ermitazh (Russia) and Shanghai gu ji chu ban she.
1997. *Eluosi guo li Ai'ermitashi bo wu guan cang Dunhuang yi shu pin* = *Dunhuang Art Relics Collected in the State Heritage Museum of Russia*. Shanghai: Shanghai gu ji chu ban she.
- Vincent, I. V. 1953. *The Sacred Oasis: Caves of the Thousand Buddhas Tun Huang*. Chicago: University of Chicago Press.

Contributors

Neville Agnew joined the Getty Conservation Institute (GCI) in 1988. He has a Ph.D. in chemistry and worked in academia in South Africa and Australia prior to changing to conservation in 1980. He has participated in many of the GCI's projects and has led the initiative in China since its beginning in 1989. He is the author of publications in research chemistry and conservation, including (with two coauthors) *Cave Temples of Mogao*. Agnew has served on the editorial board of the journal *Conservation and Management of Archaeological Sites* and on the board of the National Center for Preservation Technology and Training (a program of the U.S. National Park Service). His association with conservation in China has resulted in a number of awards: the Friendship Award of the State Council in 2000, the International Scientific and Technological Cooperation Award of the PRC in 2005, and awards from Gansu province and the Dunhuang Academy. He is currently senior principal project specialist in the Field Projects department of the GCI.

Ludmila Akmatova has a master's degree in foreign languages from the University of Abakan, Russia. Trained in tourism management at Erasmus University in Brussels and at the World Tourism Organization in Madrid, she worked in the tourism industry in Russia and Kyrgyzstan for fifteen years and since 1997 has been senior expert in the Department of International Tourism at Kyrgyzstan's State Committee for Tourism, Sports, and Youth Policy. She has been involved in the development of a World Watch heritage conservation project at Kyrgyzstan's Tash-Rabat caravansarai site and in the nomination of the Suleiman-Too sacred mountain site to the World Heritage List. She has published on issues relating to tourism and tourist sites in Kyrgyzstan and central Asia.

Kirsty Altenburg received her M.A. degree in historical archaeology from the University of Sydney. She is assistant director of the Historic Heritage Management Section of Australia's Department of the Environment and Heritage.

Peter Barker is a freelance interpreter of Chinese currently residing in Australia.

Daniela Bathelt did her diploma thesis in organic synthesis at the University of Erlangen, Germany. Since 2001 she has been involved in the China Project at the Bavarian State Department of Historical Monuments. In 2005 she completed her Ph.D. in organic chemistry at the Ludwig-Maximilians University of Munich, and she is currently working in the chemical industry at Henkel in Dusseldorf, Germany.

Jonathan Bell holds degrees in East Asian studies and anthropology from Harvard University, in art history from the Université de Paris IV–Sorbonne, and in historic preservation from Columbia University. He joined the Getty Conservation Institute in 2001, where he is currently a project specialist. Bell has been involved in heritage site management and conservation projects in China, Pakistan, Egypt, and France.

Heinz Berke has been a professor of inorganic chemistry at the University of Zurich, Switzerland, since 1988. He guides a small team exploring the chemistry and archaeometry of ancient synthetic blue and purple pigments.

Catharina Blaensdorf, conservator, was trained in the field of wooden sculpture and panel painting and received her

diploma from the Academy of Arts in Berne, Switzerland. Since 1998 she has been employed at the Bavarian State Department of Historical Monuments, Munich, on the China Project, mainly for the conservation of the polychromy of the Terracotta Warriors of Qin Shihuang.

Soraya Bouherour is an industrial chemist. She contributed to the study of ancient synthetic blue and purple pigments, applying Raman spectroscopy, while a postdoctoral fellow at the University of Zurich.

Sandra Bucher, conservator, has a master's degree in the field of stone objects and wall paintings. She trained at the Escuela Nacional de Restauración y Museografía, INAH, Mexico City, and at the University of Applied Sciences in Cologne, Germany. Since 2001 she has been employed on the China Project at the Bavarian State Department of Historical Monuments, Munich, and she is in charge of the conservation and restoration of stone armor from the burial complex of Emperor Qin Shihuang.

David Carson is laboratory manager at the Getty Conservation Institute. His research interests include the investigation of materials by electron microscopy and the use of X-ray tomography for the examination of museum objects.

Sharon Cather has been teaching wall painting conservation at the Courtauld Institute of Art since 1985, when the program was set up with the Getty Conservation Institute. She supervises Courtauld fieldwork projects internationally—currently in China, Cyprus, India, Jordan, and Malta—as well as Ph.D. research. She is a fellow of the International Institute for Conservation (IIC), the Society of Antiquaries, and the American Academy, with a particular research interest in the mechanisms of environmental deterioration.

Chen Gangquan graduated from the Department of Applied Chemistry at the Geological University at Wuhan in 1990 and is associate researcher in the Conservation Institute of the Dunhuang Academy, where he conducts analytical work related to wall paintings and earthen architecture deterioration and their conservation and restoration. He has been in charge of several projects, including those sponsored by the Ministry of Science and Technology, the Gansu Provincial Government, and the Dunhuang Academy. He also has been involved in the international collaborative projects between the Getty Conservation Institute and the

Dunhuang Academy and the Tokyo National Institute of Cultural Property and Dunhuang Academy for conserving the Mogao Grottoes. He participated in the development of the Mogao Grottoes Conservation Master Plan and the drafts for standardization of conservation work assigned by the State Administration of Cultural Heritage. He has published many articles on conservation and analysis.

Chen Genling earned his B.Sc. from the Engineering Academy of North China. Currently, he is a conservation specialist and an associate professor at the Gansu Provincial Museum.

John Cupitt earned a Ph.D. in theoretical computer science at the University of Kent. For fifteen years he worked in the scientific department of the National Gallery, London, on camera calibration, image processing I/O systems, user-interface design, the measurement of color change in paintings, and infrared imaging of paintings. Currently he is working on modeling of lung disease processes at Imperial College, Hammersmith Campus.

Martha Demas received her Ph.D. in Aegean archaeology from the University of Cincinnati in 1984 and later pursued an M.A. in historic preservation at Cornell University, specializing in conservation of archaeological heritage. She joined the Getty Conservation Institute in 1990, where she is currently a senior project specialist. She has worked in China since 1997 and has been involved in archaeological site conservation projects in Central America, Africa, the Middle East, and the United States.

Sanjay Dhar received his training in painting conservation from India's National Museum Institute for History of Art, Conservation, and Museology and the Università internazionale delle'arte, Florence, Italy. He established the conservation laboratory at the Indian National Trust for Art and Culture, New Delhi, and was its director until 2000. He has directed major conservation projects in India and is a consultant to UNESCO. He is also involved in the training of conservation professionals. At present Dhar is working mainly on the wall paintings in the Ladakh region of India.

Diao Changyu is a doctoral candidate in computer science at Zhejiang University, China. His main research interest is high-resolution digitalization and virtual display of cultural heritage.

James R. Druzik is a senior scientist at the Getty Conservation Institute, where he has worked since 1985. Previously he was at the Los Angeles County Museum of Art and the Norton Simon Museum. His work has ranged from using aerospace software to enhance X-ray images of European oil paintings to developing imaging for historic documents. His most recent research has centered on preventive conservation, including identifying gaseous and particulate air pollution effects on cultural materials and examining better techniques for safer museum lighting. He has served in advisory capacities for the National Archives and Records Administration, the Library of Congress, and the Smithsonian Institution. Druzik has been the recipient of grants from the President's Fund of the California Institute of Technology and has written or contributed to more than fifty journal articles and book publications. Between 1988 and 1996 he and Pamela Vandiver of the Smithsonian Institution organized five symposia on materials issues in art and archaeology for the Materials Research Society.

Du Mingyuan has been chief researcher at Japan's Ministry of Agriculture, Forestry, and Fisheries since 1997. He graduated from the meteorology department of Nanjing University in 1982 and received his Ph.D. from the University of Tsukuba, Japan, in 1991. His expertise is agricultural climate and weather. He has been involved in many research projects, including atmospheric and moisture movement on the Qingzang Plateau, rational use of the agricultural ecology system of the loess plateau, and the relationship between agricultural production activities and desertification in western China. He has published approximately ninety articles in professional journals.

Du Xiaofan is the cultural heritage conservation specialist at the UNESCO Office Beijing. In 2002 he joined UNESCO from the Nara National Cultural Properties Research Institute as an expert in Chinese heritage and Sino-Japanese project management. He is affiliated with Fudan University, the Center on Scientific Studies of Cultural Heritage of the Chinese Academy of Sciences, and other heritage institutes in China and Japan. Du received his Ph.D. in art history from Kobe University.

Du Xiaoli is deputy director of Hohhot Museum and director of the Inner Mongolia Ancient Wall Painting Conservation Center. She was in charge of the Dazhao Temple wall painting conservation project and received the Inner Mongolia Cultural Heritage and Archaeology Excellence

in Science and Technology Achievement Award, first rank. She was also in charge of the Liao dynasty tombs wall painting conservation project at Tuerji Mountain in Inner Mongolia. Her publication on the conservation of Dazhao Temple wall paintings was granted a second-rank award from the authority mentioned above. She has published numerous articles, including "New Discoveries on Ancient Wall Painting Manufacturing Techniques" and "Research on Liao Dynasty Tombs Wall Painting Conservation at Tuerji Mountain, Inner Mongolia."

Patrick Dudoignon is a professor at the Ecole Supérieure d'Ingénieurs de Poitiers. A specialist in rock alteration, he focuses on the damage of clay matrices under hydraulic or mechanical stress. In the collaboration with Project TERRA, he was involved in the petrographic analysis and the microstructural characterization of the model earth samples.

John Falconer is curator of photographs at the British Library, with responsibility for the library's extensive collections of nineteenth-century photography. He specializes in the history of nineteenth-century photography in Asia and was previously responsible for the library's Oriental and India Office photograph collections. He has published extensively on the development of photography in nineteenth-century India.

Fan Jinshi is director of the Dunhuang Academy, deputy chair of China ICOMOS, and member of the eighth, ninth, and tenth sessions of the National Committee of China's People's Political Consultative Conference. She graduated from the Department of History at Beijing University in 1963 with a major in archaeology. She has worked at the Dunhuang Academy since then. Her research fields are grotto site conservation, management, and archaeology. She has been in charge of many projects, including the Yulin Grottoes conservation project, the evolution of the Mogao Grottoes environment, visitor capacity and site use policy, and the Mogao site master plan, 2006–25. She contributed to volumes on Northern Zhou wall painting, Chinese wall paintings, and Buddhist painting in the Mogao Grottoes. In addition, she has edited twenty-six volumes on the Dunhuang cave temples.

Fan Yuquan is an associate scientist at the Conservation Institute of the Dunhuang Academy. He received a degree in polymer chemistry from Lanzhou University in 1987

and a Ph.D. in analytical chemistry in 2005. His research is concerned with techniques of ancient wall painting. In 2007 he was a visiting scientist at the Getty Conservation Institute.

Fan Zaixuan is associate researcher at the Conservation Institute of the Dunhuang Academy. He joined the academy in 1981. His education and professional training include degrees from the chemistry department of Northwestern University in Xi'an, the heritage conservation department at Fudan University, the conservation and preservation science department at the Art Institute in Tokyo, the Tokyo National Cultural Heritage Institute, and the Getty Conservation Institute. Most of his work has been concerned with wall painting and polychrome statue conservation projects at the Mogao Grottoes and sites in Tibet. Fan has published on pigments, grouting, treatment for detachment, and other wall painting problems. He has received awards from the State Administration of Cultural Heritage as a participant in earthen architecture and the cave 85 project.

Fu Qingyuan is chief engineer of the Chinese National Institute of Cultural Property, where he has been involved in numerous conservation, restoration, and display planning projects. While working for the State Administration of Cultural Heritage, he was in charge of finance, restoration, and approval of conservation project plans for nationally protected sites. Among other projects, he was in charge of design and planning for the Summer Mountain Resort and Outlying Temples ten-year (1986–95) conservation and restoration plan.

Kathleen M. Garland has worked in Britain, Italy, and the United States in objects and sculpture conservation. In 1987 she established the objects conservation department at the Nelson-Atkins Museum of Art in Kansas City, Missouri, where she is currently working on the Chinese sculpture collection. In 2001 she was the first Luce Fellow in Chinese Paintings Conservation at the Freer and Sackler Galleries of the Smithsonian Institution, Washington, D.C.

Gwénaelle Gautier received a B.S. degree in chemistry in 2002 from the University of Nottingham, England. She is currently finishing her Ph.D. in analytical chemistry at the University of Pisa, Italy. Her research deals with the application of gas chromatography–mass spectrometry to

the characterization of organic materials in works of art, with particular reference to wall paintings.

David Gélard graduated from the University of Poitiers in earth sciences in 2000. He obtained his Ph.D. degree from the National Polytechnic Institute of Grenoble in January 2005. He was the key person in France for the collaborative work between CRAterre, the Getty Conservation Institute, and ICCROM on the cohesion of earth.

Cecily M. Grzywacz has been a scientist at the Getty Conservation Institute (GCI) since 1985. She received an M.S. degree in chemistry in 1992 from California State University, Northridge. From 1985 to 2002 she was the staff scientist researching monitoring for gaseous pollutants in museum environments, and she continues to contribute to this area of preventive conservation. Her current research focuses on the investigation of organic colorants, specifically dyes and organic lake pigments from natural biological sources, and she is the project manager for GCI's Asian organic colorants project, a collaborative undertaking with the Dunhuang Academy and Jan Wouters, GCI consultant and conservation scientist from Belgium.

Guo Baofa earned his bachelor's degree from the Department of Archaeology, Peking University, and is a senior researcher at the Museum of the Terracotta Warriors and Horses of Qin Shihuang.

Guo Hong received his Ph.D. in engineering. He is currently an associate researcher at the China National Institute for Cultural Property. He directed the nationwide survey of the deterioration of museum-held artifacts project, sponsored by the State Administration of Cultural Heritage. His research interests encompass preservation environment of museum-held artifacts, conservation theories and techniques, and long-term development of conservation science. In addition to publishing forty articles, he is the author of the monograph *Conservation Environment of Cultural Properties* (Science Press [Beijing], 2001).

Guo Qinglin graduated from the Department of Geology, Lanzhou University, in 1999. Since then he has worked at the Conservation Institute of the Dunhuang Academy. Currently, he is studying for a Ph.D. in the geological engineering department at Lanzhou University. He has been involved in many Dunhuang Academy collaborative

projects, including those with the China National Institute of Cultural Property, Osaka University, and the Getty Conservation Institute. He has also worked on a number of projects undertaken by the Dunhuang Academy alone, such as at Jiaohe, the Han Great Wall, and the XiXia mausoleums in Ningxia.

Haida Liang is a senior lecturer in physics at Nottingham Trent University. She obtained a Ph.D. in astronomy and astrophysics from the Australian National University. Prior to her current post, she worked in the scientific department of the National Gallery in London on the development of noninvasive techniques for the examination of paintings and in the physics department of the University of Bristol and the Service d'Astrophysique of the Commissariat à l'Énergie Atomique (Saclay) on various astrophysics projects. Her main research interests in conservation science are the development and application of noninvasive imaging techniques and the study of optical properties of paint and varnish material.

Han Rubin is a professor at the Science and Technology University of China and a doctoral adviser. She has directed or participated in several conservation projects on ancient metals, especially iron artifacts. She has published more than sixty articles and several monographs.

He Ling received a master's degree in analytical chemistry in 1988 from the Science and Technology University of China and a Ph.D. in material chemistry in 2003 from Northwestern Polytechnical University, China. Her main research interest is the study of protective materials used in conservation and the use of pyrolysis–gas chromatography–mass spectrometry to analyze binding media in wall paintings. From 1992 to 1996 she took part in the Chinese-German collaboration to conserve the DaFosi Grotto in the northern part of Shaanxi province, and from 1995 to 1999 she participated in the Chinese-Italian collaboration to establish the Northwestern Center in Xi'an.

Naomi Hellmann is a graduate student in development studies at Brown University. She worked for the cultural sector of the UNESCO Office Beijing before joining the Swiss Federal Institute of Technology, where her focus was on the Shaxi Rehabilitation Project in Yunnan, China. Her research interests are heritage conservation, economic development, and poverty reduction in East Asia.

Hou Wenfang joined the Dunhuang Academy Conservation Institute in 1990 and works in the document management information group. She was transferred to the environmental group in 1995 to do environmental monitoring and data collection, compilation, and analysis. In addition, she has been involved in the study of the impacts of microenvironment changes and visitors on the art. She graduated from Nankai University in 2007, with a specialty in tourism management.

Hugo Houben is cofounder of CRATerre, the International Center for Earth Construction, a scientific organization within the School of Architecture of Grenoble, France. He is also responsible for the UNESCO Chair for Earthen Architecture (Constructive Cultures and Sustainable Development) and codirector of Project TERRA. He has been specializing in earth construction since 1972.

Huang Huaiwu is an associate researcher at the Guangxi Zhuang Ethnicity Autonomous Region Museum. His research interest is conservation of outdoor and intramural cultural properties. He directed the sampling, environmental data analysis, and experimentation subprojects for the project on mechanisms of deterioration and preventive measures for the Huashan rock paintings, sponsored by the State Administration of Cultural Heritage. He has published numerous articles on rock painting conservation.

Huang Jizhong is deputy director of the Yungang Grottoes Academy in Shanxi province. He received a master's degree from the heritage conservation department of Fudan University in 1996 and a Ph.D. in geology from the Chinese Academy of Geological Sciences in 2005. He has researched stone and grotto conservation at Yungang Grottoes since 1988. Currently, his main research areas are the impacts of environmental pollution and water on stone statues and nondestructive tests on stone relics. Huang has published extensively on these topics. He has received both a National Conservation Science and Technology Renovation Award and the Shanxi Province Scientific Technology Progress Award in 2005.

Huang Kezhong graduated from the Beijing Geological Institute in 1961. For more than forty years, he has been involved in the research and conservation of grottoes, ruins, and burial sites. Now retired from positions as senior engineer and deputy director at the China National Institute of Cultural Property, he serves as adviser to the Chinese

Heritage Information and Consultation Center. Before retirement he was a researcher at the Dunhuang Academy, a professor at the Chinese Geological University and Northwestern University, and deputy chair of the Council of the Chinese Heritage Association and the Chinese Cultural Heritage Conservation Techniques Association.

Jumamedel Imankulov, director of the scientific research and design institute Kyrghyzrestoration, has been studying Kyrghyzstan architecture for more than thirty years. Since 1997 he has also been head of the Department of Architectural Heritage Restoration at the State University of Construction, Transport, and Architecture. He has published extensively on the history and theory of architecture in central Asia and has participated in numerous state and international seminars, training events, symposia, and conferences as an expert on conservation and restoration.

Shuichi Iwata, geologist, has been studying the minerals and microfissures in complex rock formations in Japan, Egypt, and China.

Jiang Baolian received a bachelor's degree in archaeology in 1984 from Northwestern University, China. Her primary research interest is historical investigation and research in cultural heritage.

Jin Hongkui has been deputy director of the Palace Museum since 2002 and is also in charge of ancient building restoration and conservation. He graduated from Beijing University's history department in 1982 with a major in archaeology. Between 1982 and 2002 he worked first in the cultural heritage group of the Ancient Architectural Research Institute of the Beijing Municipal Cultural Heritage Bureau and subsequently at the State Administration of Cultural Heritage in the Department of Sites and Monuments Protection. His main tasks were dealing with survey of immovable heritage, conservation, restoration, and management. His important academic achievements and publications include participation in the development of the China Principles as a member of the core group, chief editor and writer for the Simatai Great Wall publication, and many articles.

Edith Joseph received a B.S. degree in chemistry from the Université de Nantes, France. She then specialized in organic and analytical chemistry and completed, at the same university, an advanced postgraduate studies diploma in

chemistry and materials in 2001. She is currently participating in a European research project that aims to develop and evaluate new treatments for the conservation-restoration of outdoor stone and bronze monuments and is completing a Ph.D. program at the University of Bologna, Italy.

Keigo Koizumi received his Ph.D in civil engineering in 2005 from Osaka University, Japan. His main research interest is the application of remote sensing to monitoring ground disasters and the global environment. He is an assistant professor at Osaka University.

Christian Lahanier is currently head of the documentation and imaging technologies department at the Centre de Recherche et de Restauration des Musées de France (C2RMF). From 1968 to 1984 he managed the Department of Physics at the Laboratoire de Recherche et de Restauration des Musées de France (LRMF) and developed X-ray technologies. In 1984 he became head of the laboratory at LRMF and acquired a particle accelerator. From 1989 to 2002 he managed or contributed to ten European Union–Research and Technology Development projects, setting up new 2D and 3D digital technologies, relational database management systems to give access, through a multilingual thesaurus, to the rich scientific documentation held at the C2RMF.

Lan Riyong is a senior researcher at Guangxi Zhuang Ethnicity Autonomous Region Museum. His research focuses on museum-held artifacts. He directed the evaluation of artistic value and the preservation environment subprojects for the causes of deterioration and preventive measures for the Huashan rock paintings project, sponsored by the State Administration of Cultural Heritage. He has published numerous articles on rock paintings, as well as several monographs.

Heinz Langhals studied chemistry in Münster, Germany, and received his Ph.D. in 1974. In 1984, after postdoctoral positions in Paris (organic chemistry) and in Zürich (physical chemistry), he became professor of organic chemistry at the Ludwig-Maximilians University, Munich. His research interests are in the field of macromolecular and organic chemistry.

Jean-Paul Laurent is a researcher at the National Center for Scientific Research (CNRS), working in the Laboratory of

Environmental Hydrology in Grenoble. He obtained a Ph.D. in 1986 in the thermal conductivity of earth. He is currently developing environmental monitoring systems.

Bo Lawergren, born in Sweden, holds a Ph.D. in nuclear physics from the Australian National University, Canberra. He is a professor emeritus at the Department of Physics and Astronomy, Hunter College of the City University of New York. Since the 1980s he has been active in two additional fields, musical acoustics and music archaeology (spanning Eurasia), resulting in fifty published articles.

Laurent Lévi-Strauss is deputy director and chief of the Tangible Heritage Section of the Division of Cultural Heritage, UNESCO. He is responsible for the coordination of UNESCO's operational activities in the field of cultural heritage conservation and preservation, notably in post-conflict and least-developed countries, including Afghanistan, Cambodia, Iraq, and North Korea, as well as throughout central Asia and in the Caucasus. This work involves some forty major operational activities, with a budget of more than US\$12.5 million.

Li Ping is associate researcher and head of the reception department at the Dunhuang Academy. She studied in the Asian and African department of the Beijing Second Foreign Language Institute and majored in Japanese between 1984 and 1986. From 1988 to 1990 she studied art history at National Hyogo University. Li Ping has translated from the Japanese *Travel with Gandhara Buddhism Arts* and *Iconography of Nirvana and Maitreya*, by Akira Miyali.

Li Weitang joined the Dunhuang Academy in 1977. His major assignments are copying of wall paintings, engineering survey and drawing, and cave measurement and survey. In the cave 85 project his tasks have been cave measurement and survey and recording of wall painting condition.

Li Yanfei has been a staff member at the Conservation Institute of Dunhuang Academy since 2001. Her main tasks are research on grotto sites, wall painting, and earthen sites conservation. She studied in the chemistry department at Xibei Normal University between 1997 and 2001.

Li Yunhe has been in the conservation field since 1956. He was appointed deputy head of the Dunhuang Academy's conservation department in 1980 and deputy director of the

Conservation Institute and director of the Yulin Grottoes in 1985. He retired in 1998 but remains a consultant to the Dunhuang Academy. He has received six awards from the Ministry of Culture, the State Administration of Cultural Heritage, and the Gansu Provincial Government and has published many professional papers.

Li Zuixiong is deputy director of the Dunhuang Academy, deputy head of the Chinese Cultural Relics Conservation Technology Council, and adviser for doctoral degrees at the Resources and Environment Institute, Lanzhou University. He received his Ph.D. in the conservation of cultural property from Tokyo National University of Fine Arts and Music and worked at the Gansu Provincial Museum from 1964 to 1995. His research focuses on the conservation of grottoes and earthen architecture sites, and he has participated in many conservation projects at such sites along the Silk Road.

Roland Lin Chih-Hung is a consultant at the Asia-Pacific Unit of the World Heritage Centre at UNESCO headquarters in Paris. He is in charge of UNESCO cultural heritage protection projects in central Asia as well as the World Heritage Silk Roads serial nomination central Asian section. In addition, Lin is a research fellow at the Centre de Recherche en Extrême-Orient de Paris-Sorbonne, IPRAUS at the Paris-Belleville Architecture School, and ATELAB at the Paris-La Villette Architecture School. He has published numerous specialized papers on the need to safeguard world and cultural heritage in Asia.

Liu Gang is a Dunhuang Academy staff member and has been involved in wall painting conservation projects with the Getty Conservation Institute and the Tokyo National Institute of Cultural Property. His main research area is environmental monitoring and digitizing techniques for applications to cultural heritage information. Currently, he serves on a standing committee of the Chinese Museum Association concerned with digitization and is deputy committee head of the information digitizing committee of the Chinese Cultural Heritage Association. He has participated in projects such as a computer storage and management system for Dunhuang wall paintings sponsored by the Gansu Provincial Scientific Committee, as well as others sponsored by the National Scientific Committee. In addition, he was involved in two phases of wall painting digitizing projects in collaboration with the Mellon Foundation. As a result of the collaboration, he was able to form a team at the Dunhuang Academy that

is capable of undertaking complicated, large-scale, two-dimensional digitizing for cultural heritage.

Liu Yang received a master's degree in computer science in 2005 from the Zhejiang University, China. His main research interest is the digitization of cultural heritage.

Lu Dongming is a professor of computer science at Zhejiang University, China. He directs a small team exploring the technology of cultural heritage digitization. His main research interest is the digitization, digital preservation, and virtual display of cultural heritage.

Lu Yanling earned a B.Sc. in chemistry from the Northwest Normal University, China. She worked at the conservation laboratory of the Gansu Provincial Museum and in 2002 became its deputy head and an associate professor. At present she is a conservation scientist at the Shenzhen Municipal Museum.

Jean-Louis Luxen, who trained in law and economics, has been Administrateur Général, Department of Cultural Affairs, Belgium, since 1981. He is also a professor at the Catholic University of Louvain and a member of the Commission Royale des Monuments et Sites, Brussels. From 1989 to 1993 Luxen served as president of the Cultural Heritage Committee of the Council of Europe; from 1993 to 2002, as secretary general of ICOMOS, with an active involvement in the implementation of the World Heritage Convention; and since 2001, as president of CHEDI (Culture, Heritage, and Development–International).

Ma Qinglin earned a Ph.D. in chemistry from Lanzhou University, China. He was a visiting conservation scientist at the Getty Conservation Institute in 2001 and a postdoctoral fellow at the Inorganic Chemistry Institute of Zurich University in 2003. He worked at the Gansu Provincial Museum from 1986 to 2004 as head of the conservation laboratory and later become the deputy director of the museum. At present he is a senior scientist and deputy director of the China National Institute of Cultural Property in Beijing.

Ma Tao, who holds a master's degree in environmental science from Beijing University, has been chief conservator at the Xi'an Center for the Conservation and Restoration of Cultural Property, Shaanxi province, since 1989. His current

work focuses on the conservation of stone, clay sculptures, and polychromy and environmental studies.

Ma Zanfeng, assistant researcher in the Conservation Institute of the Dunhuang Academy, has a master's degree in conservation from Xi'an Northwestern University. He is currently a science and technology doctoral candidate at the University of Beijing. Since 1997 he has worked at the Conservation Institute of the Dunhuang Academy.

Richard Mackay was chair of the Jenolan Caves Reserve Trust from 2001 to 2004 and a board member from 1992 to 2004. He is a director of Godden Mackay Logan, a leading Australian heritage consultancy firm. He has expertise in cultural resource management and extensive experience as a team leader, project director, and facilitator for heritage management and archaeological projects.

Shin Maekawa is a senior scientist in charge of the Environmental Studies Laboratory of the Getty Conservation Institute, overseeing and conducting research on climate control technologies for historic buildings as well as microclimates of cultural objects for conservation. He conducted nitrogen anoxia research for conservation that resulted in the publication of three books. Maekawa earned a B.S. in engineering applied mechanics from the University of California, San Diego, an M.S. in mechanical engineering from the University of California, Los Angeles, and a Ph.D. in conservation science from Tokyo National University of Fine Arts and Music. He is a registered professional engineer (mechanical) in the state of California.

Fred H. Martinson is an art historian specializing in the history of Buddhist art. He received a Ph.D. in Japanese and Chinese art history from the University of Chicago in 1968 under the mentorship of Harrie A. Vanderstappen. He has lived and traveled in Japan, Hong Kong, China, and Taiwan. Martinson retired from the University of Tennessee in May 1998 as professor emeritus of art and a member of the Asian Studies Committee.

Tadashi Masuya has extensive experience in geophysical exploration for disaster prevention and civil construction. Since 1995 he has been a member of and has guided many project teams working on stone heritage conservation, for example, conservation of the Great Sphinx.

Joy Mazurek has been an assistant scientist at the Getty Conservation Institute since 1998. She specializes in the identification of organic materials by gas chromatography–mass spectrometry. She obtained a master’s degree in biology, with emphasis in microbiology, from California State University, Northridge, and has a B.S. degree in biology from the University of California, Davis. She is currently using antibodies to identify binding media.

Rocco Mazzeo received a degree in chemistry in 1980 from the University of Bologna, where he is professor of chemistry for restoration and director of the bachelor’s and master’s degree courses in science and technology for the conservation of cultural heritage. His current research interests are the analysis of the materials and production techniques of mural paintings and their conservation, as well as Renaissance outdoor bronze monuments.

Pan Yunhe is a graduate of Tongji University and holds a master’s degree from Zhejiang University. He was president of Zhejiang University, having been a professor of computer science there. In 1997 he was elected a member of the Chinese Academy of Engineering and is a pioneer in the field of intelligent computer-assisted design and computer art. His intelligent computer-assisted design system for art pattern creation has resulted in remarkable profits in the textile industry. Pan is currently vice president of the Chinese Academy of Engineering and an alternate member of the 17th Communist Party of China Central Committee.

Anne Pantet obtained her Ph.D. from the Institut National des Sciences Appliquées in Lyon in 1991. She is currently assistant professor of civil engineering at the University of Poitiers, working on the structural-mechanical property relationship in clays with variable water content.

Chunze Piao, a geological engineer, received his engineering geology degree from the University of Jilin, China, in 1996, and his master’s degree from the Department of Global Architecture at the University of Osaka, Japan, in 2001. Since 2004 he has been employed by the Hytec Company, a geology consulting firm in Japan. His main research interests are geotechnical and hydrogeological investigations.

Francesca Piqué earned a diploma in wall painting conservation and an M.S. from the Courtauld Institute of Art, University of London. She worked at the Getty Conservation

Institute for more than twelve years on archaeological, mosaic, and wall painting conservation projects worldwide. She currently resides in Italy. Piqué has published numerous articles and two books on wall painting and mosaic conservation and teaches in various institutions.

Armin Portmann is a retired specialist in electron microscopy working at the University of Zurich. He provided SEM/EDX measurements for the study of ancient synthetic blue and purple pigments.

Silvia Prati received a degree in chemistry in 1999 and a Ph.D. in environmental chemistry in 2002 from the University of Bologna, Italy. Her main research interest is the application of analytical pyrolysis coupled with gas chromatography–mass spectrometry to address problems concerning the conservation of cultural heritage.

Qiao Hai is a wall painting conservation technician and has been employed by the Dunhuang Academy since 1999 in conservation projects at the Mogao and Yulin Grottoes, the Potala Palace, and other international collaborative projects such as the cave 85 and cave 53 projects and the Mogao Grottoes site carrying capacity study. He also participated in training courses, including the Wenzhou polychrome statue and earthen architecture conservation programs. He graduated from the Xi’an Army Academy Department of Economic Management.

Qiu Fei joined the Conservation Institute of Dunhuang Academy in July 2001. His main task is windblown sand monitoring and research at the Mogao Grottoes. He graduated from the Ecology Engineering program at Gansu Forestry Technology Institute in June 2001, after which he enrolled in the Beijing Forestry University Adult Educational Academy forestry program between 2001 and 2003 and received a diploma.

Leslie Rainer is a conservator of wall paintings and senior project specialist at the Getty Conservation Institute (GCI). She has worked on conservation projects internationally, specializing in decorated surfaces on earth. She was a member of the GCI team on the Mogao project from 1998 to 2001. She received an independent master’s degree in the conservation of architectural surfaces from Antioch University in 1991 and a certificate from ICCROM in mural paintings conservation in 1990. Rainer won the Rome Prize

Fellowship in Conservation and Historic Preservation in 1998–99. She is a member of the American Institute for the Conservation of Historic and Artistic Works, the International Institute for Conservation, and the International Commission on Monuments and Sites.

Akbar Rakhimov is director of the Rakhimov Museum and head of the UNESCO-sponsored school for traditional ceramics in Tashkent. He is a practicing potter, artist, and designer whose work is displayed in museums in Russia, Germany, Japan, Turkey, France, and Uzbekistan. Awarded a Distinguished Master of Ceramics of Uzbekistan in 1991, he became a full member of the Uzbek Academy of Arts in 1997 and has also received the UNESCO certificate of achievement. He was a co-organizer of the symposium and exhibition *Blue Ceramic of Samarkand*, sponsored by UNESCO in 1998, and the Symposium on Uzbek Traditional Ceramics in September 2001. He traces a continuous family lineage of ceramic masters to the late eighteenth century.

Alisher Rakhimov, the son of Akbar Rakhimov, is a distinguished ceramic master. He is a teacher and administrator at the school for traditional ceramics and also maintains his own ceramics studio. He has mastered some of the techniques of the black, brown, yellow, and blue Kashgari pottery as well as the *ishkor* process. He was awarded a fellowship to study in Japan at traditional workshops where overglaze enameling is practiced. In addition, he has presented workshops on Silk Road ceramic techniques and successfully exhibited his work.

Stephen Rickerby is a private wall painting conservator and has been a consultant on a number of Getty Conservation Institute projects, including the tomb of Nefertari in Egypt, the Royal Palaces of Abomey in Benin, and the cave 85 project at Mogao. He has been involved with conservation teaching in China, including the ongoing, three-year postgraduate course in wall painting conservation being held at Mogao. He also co-supervises the fieldwork sites of the Courtauld Institute of Art, London.

David Saunders joined the British Museum after twenty years in the scientific department at the National Gallery in London, where his areas of research included the effect of the environment on paintings and on artists' materials, preventive conservation, and the application of imaging techniques to the examination of paintings. He has been

an editor of the journal *Studies in Conservation* since 1990 and served on the technical committees for the 1994 and 2000 congresses. Since January 2003 he has been director of publications for the International Institute for Conservation (IIC) and a member of the IIC Council.

Michael R. Schilling is a senior scientist and head of the Analytical Technologies section at the Getty Conservation Institute (GCI). His research interests include analysis of natural organic materials used as paint media and varnishes, modern paints, and plastic sculptures. He has been involved in several GCI projects at the Mogao Grottoes since 1989.

Sekhar Chandra Set is an architect, city planner, and artist. He received a bachelor of architecture degree in 1966 from Calcutta University, a master's degree in city planning in 1971 from the Indian Institute of Technology, Kharagpur, and a Ph.D. in painting in 1991 from Rabindra Bharati University, Calcutta. He has been a lecturer at the Indian Institute of Technology, a guest lecturer at Rabindra Bharati University, and an assistant professor (reader) and department head at Bengal Engineering College. Set is the recipient of national awards in landscape architecture, painting, and music (violin). He is also a member of the Indian Institute of Architects and the Institute of Town Planning, India. His special fields of interest are urban aesthetics and wall paintings.

Lisa Shekede, a private wall paintings conservator, was a consultant on the cave 85 project at the Mogao Grottoes from 2000 to 2004. She currently co-supervises the fieldwork programs of the Courtauld Institute of Art master's degree program in wall painting conservation and is an instructor for the postgraduate course in wall painting conservation being held at Mogao. Her particular areas of expertise are the technology and conservation of wall paintings on earthen supports.

Shuya Wei is a scientist at the Institute of Science and Technology in Art, Academy of Fine Arts, Vienna, Austria. In 2007 she received her doctorate at the University of Technology in Vienna. Between 1999 and 2002 Shuya received two master's degrees, in the principles of conservation and conservation in archaeology and museums, from University College, London. As a graduate intern at the Getty Conservation Institute in 2003, she was involved in the investigation of materials used in decorative painting of Chinese Qing dynasty architecture, as well as the study

of wall painting degradation mechanisms at the Mogao Grottoes due to salt migration. Her current work focuses on the study of organic materials by a combination of pyrolysis–gas chromatography–mass spectrometry and Fourier transform infrared techniques.

Su Bomin is director of the Conservation Institute at the Dunhuang Academy and standing deputy director of the Ancient Wall Painting Conservation Science and Technology Research Center, State Administration of Cultural Heritage (SACH). He has received awards from SACH. He is the author of numerous professional articles. He was a visiting scholar in 2000–2002 at the Tokyo Art Institute and in 2006 at the Getty Conservation Institute.

Sharon Sullivan is the retired executive director of the Australian Heritage Commission and the former Australian government representative on the World Heritage Committee. She has worked and published extensively on cultural heritage management issues for thirty years, in Australia and overseas, including the United States, China, Africa, and Cambodia. She is the author of a range of publications, including, with Michael Pearson, *Looking after Heritage Places*, 2nd ed. (Melbourne University Press, 1998). Sullivan has been a cultural heritage consultant for the Australian government, the World Bank, the World Monuments Fund, the Getty Conservation Institute, and the government of the People's Republic of China. She is an adjunct professor at the University of Queensland, James Cook University of North Queensland, and the University of New England. She is a fellow of the Academy of the Humanities, an honorary life member of ICOMOS, a member of the Institute of Aboriginal and Torres Strait Islander Studies, deputy chair of the NSW Heritage Council and the Port Arthur Historic Site Authority, and chair of the National Cultural Heritage Forum. She has been awarded an honorary doctorate by James Cook University, and in January 2005 she was appointed an Officer in the Order of Australia for her service to cultural heritage conservation.

Sun Hongcai joined the Dunhuang Academy in 1972. Currently he is working in the academy's Digital Center. Between 1972 and 1996 he worked on wall painting and statue restoration in the Conservation Institute. He started documentation photography in 1977 and took the photographs used for documentation and for the wall painting condition assessment in the cave 85 project.

Sun Yihua is an associate researcher with the Conservation Institute, Dunhuang Academy. She has participated in many survey, planning, and restoration projects, among them the Binlin Temple, the Yulin Grottoes, and the Mogao Grottoes. Her major publication is a compilation of the architectural painting and grotto architecture at Mogao.

Tang Wei is a wall painting conservation technician and has been employed at the Dunhuang Academy since 2001. He has been involved in conservation projects at the Mogao Grottoes, the Yulin Grottoes, and the Lhasa Potala and Norbulinka Palaces, as well as international collaborative projects such as the cave 85 and cave 53 projects and the cave carrying capacity study at Mogao. He graduated from the Northwestern University (Xi'an, Shaanyi) Department of Cultural Heritage and Museum.

Chikaosa Tanimoto has been a professor of civil engineering at Osaka University, Japan, since 1997. He has chaired the international commission for the preservation of natural stone monuments since 1995. He guides a team exploring origins and movement of groundwater around the Mogao Grottoes.

Tie Fude has a doctorate from the Beijing Science and Technology University and is a professor at the China National Museum. His research interests include materials analysis, history of science and technology, and conservation technology. He has been involved in various projects, including nonmetallic replication of bronzes, control of corrosion of ancient bronzes, and preservation of wall paintings from Tang tombs.

Henri Van Damme has been a professor of physical chemistry and materials science at the Ecole Supérieure de Physique et Chimie Industrielles (ESPCI) in Paris since 1999. He is primarily interested in the chemico-mechanics of fine-grained cohesive materials and their interactions with polymers and has a growing interest in earthen materials and conservation. He is currently collaborating with CRATERRE-EAG, ICCROM, and the Getty Conservation Institute on Project TERRA.

Ron van Oers received a Ph.D. from Delft University of Technology (the Netherlands) in 2000 on research into the principles of Dutch colonial town planning between 1600 and 1800. Currently he is chief of unit for Latin America

and the Caribbean at UNESCO's World Heritage Centre. He is also a research fellow at Delft University. He is a voting member for the Netherlands in the ICOMOS International Scientific Committee on Cultural Routes.

Lucien M. van Valen received a master's degree in fine arts at the Gerrit Rietveld Academy in Amsterdam (1981) and in Chinese languages and cultures at Leiden University (1997). In 2005 she received a Ph.D. from Leiden University, combining both her fields of interest in her thesis, "The Matter of Chinese Painting, Case Studies of Eighth-Century Murals." Her current research is on Chinese painting techniques from 1200 to 1644.

Amy Vandiver is a senior remote sensing and software engineer at Scientific Solutions, Inc., and has worked on a variety of appropriate technology, archaeology, and underwater acoustics problems. She has dual B.A. degrees in geoscience and electrical and computer science and an M.S. in underwater acoustic sensing of archaeological sites from the Massachusetts Institute of Technology. Her main interests are geological resource survey, telemetry of whales, critical parameters sensing and evaluation of racing sailboats, and wilderness emergency medicine.

Pamela B. Vandiver is a professor at the University of Arizona, where she directs the Ph.D. program in heritage conservation science. Previously, she was a senior research scientist at the Museum Conservation Institute of the Smithsonian Institution. She received M.S. and Ph.D. degrees in materials science and engineering from the Massachusetts Institute of Technology, but she also has an M.A. in studio art and anthropology and a background of undergraduate studies in Western humanities and Asian studies. Her main research interests are in the analysis, reconstruction, and preservation of the ancient technologies of ceramics, glasses, plasters, pigments, and slags. In 2006 she received the Pomerance medal from the Archaeological Institute of America for scientific contributions to archaeology.

Harlan Wallach is the U.S.A. project director and media architect for academic and research technology at Northwestern University in Evanston, Illinois, where he leads research initiatives in the digital humanities and cultural heritage. He has worked with the Dunhuang Academy for more than ten years, advising on digitization projects. He has led similar efforts elsewhere in Asia as well as in Africa.

Wang Hui has been engaged in the conservation of historic buildings since he graduated in 1990 from Tongji University, Shanghai. He was employed at the Hebei Provincial Conservation Institute of Historic Buildings and the Hebei Provincial Administration of Cultural Heritage. From 1997 to 1999 he worked in Tibet as chief engineer for the conservation programs in the Ali region. Sponsored by the Ford Foundation, he completed his M.Phil. degree at the University of Bath, U.K., in 2006.

Wang Jinyu is an associate researcher in the Conservation Institute at the Dunhuang Academy. He is also a committee member of the Chinese Society for History of Science and Technology and of the Chinese Cultural Heritage Association. He graduated from the Department of Chemistry at Lanzhou University in 1978 and obtained a master's degree in heritage conservation from Fudan University in 1990. He has been involved in some thirty conservation research projects at the Mogao Grottoes, including international projects with the Getty Conservation Institute and the Tokyo National Research Institute of Cultural Properties. He has published some two hundred articles. His major publication is a volume on the science and technology of painting at the Mogao Grottoes.

Wang Tao is director of the Cold and Arid Regions Environment and Engineering Research Institute, Chinese Academy of Science. He is director of the International Center for Research and Training on Desertification Control, organized by the United Nations Environmental Program and the Chinese National Environmental Protection Agency. In addition, he is chair of the International Desert Research Association and chief editor of the *Journal of Chinese Deserts*. He has been in charge of or involved in many national projects and received the Chinese Science Academy Science and Technology Improvement Award, second rank, in 1997.

Wang Wanfu is deputy director of the Conservation Institute at the Dunhuang Academy, as well as deputy director of ancient wall painting conservation at the National Scientific Research Center and deputy chair of the China ICOMOS grotto sites conservation committee. His research fields are wall painting conservation, environmental research in arid climates, and management of grotto sites.

Wang Xiaowei graduated from the computer science department at the Normal University in 1998. Since graduation

he has been at the Dunhuang Academy. Currently, he is in charge of wall painting conservation and information and documentation management. In the cave 85 project he was tasked with digitizing wall painting condition documentation. He is enrolled in the wall painting conservation master's degree course of Lanzhou University and the Dunhuang Academy with the support of the Courtauld Institute of Art and the Getty Conservation Institute.

Wang Xudong, deputy director of the Dunhuang Academy, majored in hydrogeology and engineering geology at Lanzhou University. In 2002 he earned a Ph.D. in cultural heritage protection from Lanzhou University. His research focuses on the conservation of grottoes and earthen architecture sites, and he has participated in many conservation projects at such sites along the Silk Road. He has published more than thirty papers, won nine national-level and provincial-level awards for his conservation projects, and been awarded two patents.

Susan Whitfield is director of the International Dunhuang Project at the British Library, where she has worked since completing her Ph.D. in Chinese history at the University of London. Her current research interests include the history of the eastern Silk Road, forgeries, Chinese historiography, and the role of central Asia in world history.

Hans-Georg Wiedemann, a retired industrial scientist, developed and established thermal analysis as an analytical method. He has conducted numerous archaeometric studies, especially of synthetic blue pigments, using primarily thermoanalytical methodologies.

Ferdinand Wild is a senior chemist with the research group of Heinz Berke at the University of Zurich. He is investigating modern routes to the synthesis of blue and purple pigments.

Lorinda Wong is a wall painting conservator and project specialist at the Getty Conservation Institute. She has worked on the Valley of the Queens project in Egypt and the conservation of Qing dynasty painted architectural decoration at Shuxiang Temple, Chengde. At the Mogao Grottoes she has been involved in both the conservation of wall paintings project in cave 85 and, most recently, the visitor carrying capacity study for the site.

Jan Wouters earned a Ph.D. in chemistry and biochemistry at the University of Ghent, Belgium, in 1978. Since 1982 he

has been a conservation scientist with a particular interest in the analysis of natural organic materials used in works of art and culture. He has been a contractant in several European research projects, an expert invited by the European Commission, a supervisor of Ph.D. theses, an organizer or co-organizer of international conferences on cultural heritage, a teacher of several aspects of conservation science, and the author of more than one hundred publications in journals, books, and congress proceedings. He is coeditor of *e-Preservation Science* and a member of the editorial board of *Restaurator*. He is a member of the Advisory Committee of the Netherlands Institute for Cultural Heritage (ICN), Amsterdam, the Netherlands. From 2005 to 2008 he was chair of the International Committee for Conservation of the International Council of Museums (ICOM-CC).

Xia Yin, a chemist, received a master's degree from Northwest University in Xi'an. Since 1998 he has been working in the conservation department of the Museum of the Terracotta Warriors and Horses of Qin Shihuang, Lintong. He specializes in materials analysis of archaeological objects.

Xie Riwan is a senior researcher at Guangxi Zhuang Ethnicity Autonomous Region Cultural Properties and Archaeology Institute. His research is focused on conservation and archaeology. He directed the assessment of historical value and experimental components of the project on the mechanisms of deterioration and preventive measures for the Huashan rock paintings project, sponsored by the State Administration of Cultural Heritage. He has published more than twenty articles on rock paintings.

Xu Shuqing joined the Dunhuang Academy in 1977. Her main tasks have been copying of wall paintings, archive management, and conservation work. She participated in projects at Qinghai Qitang Temple between 1990 and 1995 and a number of other national and international projects. She received a Conservation Science Innovation Award, second rank, in 2004 from the State Administration of Cultural Heritage as one of the participants in the cave 85 project. Xu received advanced training at Tokyo National Institute of Cultural Properties in 2001.

Xue Ping became a tour guide for the Dunhuang Academy's reception department in 1986. He studied at Shanghai Fudan University between 1993 and 1996 and specialized in cultural objects conservation techniques. He transferred to the

Dunhuang Academy Conservation Institute in 1989 to conduct cave environmental monitoring and research. In 2000 he was assigned as head of the environmental group, and in April 2002 he became a staff member. He has been enrolled in the Gansu Television and Broadcasting University and has worked on computer science technology and applications since 2006.

Yang Jinjian is a wall painting conservation technician and has been employed by the Dunhuang Academy since 1994. Between 1994 and 2000 he worked for the security department and then transferred to the Conservation Institute to conduct wall painting conservation work. He has been involved in conservation projects at the Mogao Grottoes, the Yulin Grottoes, the Potala Palace, and the Lanzhou Zhuangyan Temple. At the Mogao Grottoes he participated in the cave 85 and cave 53 projects and the site carrying capacity study. He also participated in various training courses, including those in the earthen architecture program and the wall painting and polychrome statue conservation and restoration program in 2003.

Yang Mangmang received a degree in chemistry in 1987 from Northwestern University, Xi'an. Her primary research interest is conservation of metal objects, textiles, and wall paintings. She was responsible for the conservation of gold and silver wares of the Famen temple and has also taken part in many important conservation projects in Shaanxi province.

Yu Zongren has been a staff member of the Conservation Institute of the Dunhuang Academy since 2000. His work mainly involves research on grotto sites, wall painting, and earthen site conservation. He studied at the chemistry department at Xibei Normal University between 1996 and 2000.

Yuan Sixun is a professor in the College of Archaeology and Museology, Peking University.

Mokhtar Zabat obtained a Ph.D. from the University of Orléans, France, for work on the structure and mechanical properties of thin clay deposits, with Henri Van Damme as supervisor. After a postdoctoral contract in nanosciences in Japan and another in Canada, he joined the University of Boumerdes, Algeria, where he is now an assistant professor of physics.

Zhang Guobin graduated from the Gansu Agriculture University in 2002 with a major in desert control. He has been employed by the Dunhuang Academy to conduct environmental monitoring and data analysis, including the cave 85 project, windblown sand control and mitigation system planning and research, and three Tibetan restoration projects since August 2002. His main research areas are grotto site conservation and environmental control. He has participated in the development of new types of growth promoter and its application to a vegetation wind fence.

Zhang Lizhu taught in a countryside middle school and researched Marxist theory in the publicity department of the Hebei Provincial Committee of the Communist Party before being transferred to the Hebei Provincial Culture Department to manage culture-related issues. In 1993 he was appointed director of the Hebei Provincial Museum. In 1997 he was appointed director of the Hebei Provincial Cultural Heritage Bureau. In 2005 he became an inspector at the Hebei Provincial Culture Department.

Zhang Lu is a senior engineer at the Dunhuang Academy. He joined the Dunhuang Academy Conservation Institute in 1999. His research focuses on the conservation of cave temples and earthen sites.

Zhang Weimin is a researcher at the Cold and Arid Regions Environment and Engineering Research Institute, Chinese Academy of Science. His main research area is windblown sand landforms and sand control engineering. He has been involved in projects applying surface 3D photography to study the dynamic process of crescent sand dune development and the process of desertification and its control in northern China. He received a number of awards as a project participant and has published many articles.

Zhang Wenbin was director-general of China's State Administration of Cultural Heritage within the Ministry of Culture between 1996 and 2004. After retirement, he continued as a member of the National Committee, Chinese People's Political Consultative Conference. His entire career has been in the field of archaeology and culture. In addition, he has held several senior positions within the provincial and national Chinese Communist Party system.

Zhang Yongjian, conservator, trained in Germany and Italy in the field of restoration of glass, ceramic, and metal objects.

Zhang Zhijun has been the deputy head of the conservation division of the Museum of Terracotta Warriors and Horses of Qin Shihuang since 1989 and is in charge of conservation of and research on the site and its artifacts. He graduated from Northwestern University, China, in 1982 with a major in chemistry and has worked at the museum since that time. He has been involved in many projects, among them conservation of the polychrome terracotta figures and restoration of the bronze chariot from the Qin tomb. These were granted second-rank National Science and Technology Awards. He has published more than forty articles and books. He also received the Shaanxi Outstanding Expert Award in 2003 and the National Outstanding Expert Award in 2004.

Zhen Gang received a degree in restoration and conservation in 1995 from Northwestern University, China. His main research interest is the conservation and restoration of cultural heritage.

Zheng Jun has been working in the field of conservation since 1986, focusing mainly on decorated surfaces of architecture and polychrome sculpture. He has conducted various projects and taught many training courses. He

received a B.Sc. in applied chemistry from Beijing University in 1986, a postgraduate diploma from the conservation of wall painting department at the Courtauld Institute of Art, University of London, in 1994. Between 2003 and 2007 Zheng undertook research at the Courtauld Institute on conservation planning for heritage sites. He was awarded a Ph.D. in 2008.

Zhong Shihang graduated from the Beijing Geology College and is currently a senior researcher at the China Academy of Railway Sciences. He has participated in and directed several sensing projects, including those at the Palace Museum; the Kizil, Yungang, and Longmen Grottoes; and Dazu Baodingshan. He has invented a number of techniques and published more than one hundred scholarly articles.

Zhou Shuanglin earned a Ph.D. in conservation from Peking University and is currently an associate professor in the university's College of Archaeology and Museology. He has directed several conservation projects, including one funded by the State Administration of Cultural Heritage, and has also published numerous articles.

Zhou Weiqiang received a bachelor's degree in chemistry in 1995 from Zhongnan University, China. His primary research interest is the conservation and restoration of cultural heritage.

The Getty Conservation Institute

The Mogao grottoes, a World Heritage Site near the town of Dunhuang in western China, are located on the edge of the Gobi Desert, along the ancient caravan routes—collectively known as the Silk Road—that once linked China with the West. Founded by Buddhist monks as an isolated monastery in the late fourth century, Mogao grew gradually over the following millennium, as monks, local rulers, and travelers carved hundreds of cave temples into a mile-long rock cliff, and adorned them with vibrant murals portraying episodes from Buddhist scripture, luxuriant portraits of Silk Road rulers, and richly detailed scenes of everyday life. The Mogao caves developed into a spiritual and artistic mecca whose renown extended from the Chinese capitals to the far western reaches of Central Asia.

Today there remain more than 490 grottoes, the walls of which are decorated with some 45,000 square meters of wall paintings, making Mogao one of the world's most significant sites of Buddhist art. This volume contains the proceedings of the second conference on the conservation of Silk Road grotto sites cosponsored by the Getty Conservation Institute and the Dunhuang Academy, under the aegis of the State Administration of Cultural Heritage of the People's Republic of China.

Neville Agnew, senior principal project specialist at the GCI, is the author of numerous publications in research chemistry and conservation, including (with two coauthors) the book *Cave Temples of Mogao: Art and History on the Silk Road*.



Getty Publications

(800) 223-3431

www.getty.edu/publications

ISBN 978-1-60606-013-1



9 781606 060131 90000

Printed in China