

LAETOLI PROJECT

Conservation of the hominid trackway at Laetoli, Tanzania



1995 REPORT

The Getty Conservation Institute

THE GETTY CONSERVATION INSTITUTE

LAETOLI PROJECT

Conservation of the hominid trackway site at Laetoli, Tanzania

REPORT ON THE 1995 FIELD SEASON

(July 3- September 2, 1995)

This report contains unpublished material and copyrighted photographs.
It may not be reproduced without prior consent of the Getty Conservation Institute

June 1996

© J. Paul Getty Trust. Select images © John Reader © Tim White. All rights reserved.

LAETOLI PROJECT
REPORT ON THE 1995 FIELD SEASON

CONTENTS

EXECUTIVE SUMMARY

PART I. INTRODUCTION	1
(M. Demas, N. Agnew)	
<ul style="list-style-type: none">• Background• Overview of the 1995 field campaign• Terminology used in this report• Re-location and numbering of hominid and animal prints• A note on the plans and sections• <i>Appendix A</i> Members of the Laetoli Consultative Committee• <i>Appendix B</i> Laetoli Project participants• <i>Appendix C</i> 1995 Laetoli Project schedule	
PART II. RE-EXCAVATION OF THE TRACKWAY	12
(F. Marshall)	
<ul style="list-style-type: none">• Introduction• Schedule of activities• Survey of the 1995 trench and relocation of the 1979 trench• Characteristics of the 1979 reburial fill and methods of excavation• Excavation of Trenches 1, 2, and 3• Exposure of 1979 trench walls and features• Exposure of the footprint tuff surface• General description and condition of the footprint tuff surface• Roots and vegetation• Fauna• Mapping• Conclusions• <i>Appendix A</i> 1995 Grid and Datum Points	
PART III. DISTURBANCE TO THE TRACKWAY AND TEST SITE 3	26
(M. Demas)	
<ul style="list-style-type: none">• Introduction• The trackway disturbance• Test Site 3• Conclusion	
PART IV. CONSERVATION OF THE TRACKWAY	29
(J. Podany, A. Bass, E. Sanchez)	
<ul style="list-style-type: none">• Introduction• Re-excavation of the footprint tuff surface and the footprints• Condition surveys and recording of conservation treatments• Bedacryl coating and removal from G1-26 and G2/3-25• Consolidation and re-attachment of the footprint tuff• Stump and root removal	

- Conclusions
- *Appendix A* *Graphic condition survey*
- *Appendix B* *IR spectra of resin sample*

PART V. ACACIA AND OTHER VEGETATION ON THE TRACKWAY	40
(N. Agnew, A. Bass, P-M. Lin)	
<ul style="list-style-type: none"> • Assessment of damage to the trackway from acacia trees • Review of previous treatment of acacia trees with herbicide • Distribution and growth pattern of the trees growing on trackway • Treatment of stumps and roots on the trackway • Role of plants in rock deterioration • Identification of vegetation at Site G • <i>Appendix A</i> <i>Vegetation recorded at Site G in 1995 and 1994</i> 	
PART VI. DRAINAGE CONTROL AND SITE STABILIZATION	48
(N. Agnew)	
<ul style="list-style-type: none"> • Introduction • Control of drainage • NW gully and adjacent stabilization • Protection against cattle 	
PART VII. PHOTOGRAPHY AND VIDEO RECORDING	52
(T. Moon)	
<ul style="list-style-type: none"> • Introduction • Photographic equipment and film • General site photography • 8 x 10 Polaroid photography • Photogrammetry • Photography of individual footprints • <i>Appendix A</i> <i>Equipment list for the Laetoli Project</i> • <i>Appendix B</i> <i>The 12' tripod</i> • <i>Appendix C</i> <i>Fabrication drawing of the camera bracket</i> 	
PART VIII. AIMS OF THE PHOTOGRAMMETRIC DOCUMENTATION	63
(G. Palumbo)	
PART IX. REPORT ON THE PHOTOGRAMMETRIC FIELD CAMPAIGN	66
(H. R��ther)	
<ul style="list-style-type: none"> • Introduction • Objective of the field campaign • Preparations • Engineering survey • Photographic processing • Photogrammetric data processing • Ortho-image generation • Digital image quality • Results • Conclusions • <i>Appendix A</i> <i>Positions of frame points</i> 	

PART X. DESCRIPTION AND INVENTORY OF TRACKWAY MOLDS AND CASTS	106
(M. Demas, A. Bass)	
<ul style="list-style-type: none"> • Introduction • Southern trackway • Northern trackway • Individual prints • <i>Appendix A</i> 1995 inventory of Laetoli footprint molds and casts • <i>Appendix B</i> Segments of 1979 molds and casts 	
 PART XI. 1995 MOLDING AND CASTING ACTIVITIES	 110
(R. Street)	
<ul style="list-style-type: none"> • Introduction • Patination of a cast for Dar es Salaam Museum exhibit • Transportation and repair of the section A mold • Casting of the Section A mold • Evaluation of other 1978-79 molds and casts • Molding and casting of sections C and E • Inventory and storage of molds and casts • <i>Appendix A</i> Location of tears on Section A mold 	
 PART XII. MINERALOGICAL AND HYDROLOGICAL STUDY	 114
(E. Doehne)	
<ul style="list-style-type: none"> • Introduction • Site Observations • Testing and Analysis • Strike and Dip Determination • <i>Appendix A</i> Site plan with locations for testing moisture • <i>Appendix B</i> Quantitative Composition of Laetoli tuff samples • <i>Appendix C</i> Water content profiles • <i>Appendix D</i> Grain size distribution 	
 PART XIII. REBURIAL OF THE TRACKWAY AND MONITORING TRENCH	 120
(M. Demas, N. Agnew, A. Bass)	
<ul style="list-style-type: none"> • Introduction • Selection, description and preparation of reburial materials • Placement of reburial materials • SW corner drainage • Monitoring reburial trench at Test Site 3 • Conclusions 	
 PART XIV. SITE SECURITY AND MONITORING	 135
(M. Demas, N. Agnew)	
<ul style="list-style-type: none"> • Introduction • Site security • Site monitoring and management • Involvement of the Maasai community 	

- *Appendix A Report on the role of the Maasai traditional religious leader (Oloiboni) in the preservation of the Laetoli footprints in the 1995 campaign (by Godfrey Olle Moita)*

PART XV. CONCLUDING REMARKS **138**
(M. Demas, N. Agnew)

PART XVI. LAETOLI BIBLIOGRAPHY **141**
(compiled by L. Kincheloe)

OTHER REPORTS FROM THE 1995 CAMPAIGN

Reports from Tanzanian colleagues

- A summary report on the July-August, 1995 field trip (J. Bujulu)
- A summary report on the molding and casting techniques (J. Temba and M. Lilombero)

Reports from the palaeoanthropological restudy

- Microstratigraphy and taphonomy of hominid footprints at Laetoli (C. Feibel)
- Functional interpretation of the Laetoli footprints (P. Schmid)
- Preliminary morphological assessment of the hominid footprints at Laetoli (B. Latimer)

PHOTOGRAPHS 1-37

FIGURES 1-14

LIST OF FIGURES

- Fig. 1 General map of Site G, Laetoli
- Fig. 2 Plan of southern trackway showing relative positions of 1979, 1993, and 1995 excavation trenches
- Fig. 3 Plan of southern trackway showing relative positions of 1979 and 1995 excavation trenches and section lines (A-A¹, B-B¹, C-C¹, D-D¹)
- Fig. 4 Location of major datum points (E1, E2, W1, W2, S)
- Fig. 5 Plan of southern trackway showing excavated features
- Fig. 6 Plan of southern trackway showing acacia stumps and roots in relation to excavated features
- Fig. 7 Photogrammetric contour map of southern trackway with 1979 and 1995 trench lines, and selected 1979 features
- Fig. 8 Section A-A: E-W section of north wall of the 1995 trench showing the 1979 burial mound and the trackway surface
- Fig. 9 Section B-B: N-S section showing the 1979 burial mound, 1995 disturbance, and re-excavated trackway surface
- Fig. 10 Section C-C: N-S section showing the 1995 and 1979 east trench walls
- Fig. 11 Section D-D: N-S section of 1995 reburial
- Fig. 12 Fig. 13.2 in Leakey and Harris 1987
- Fig. 13 Fig. 64 in Day 1986
- Fig. 14 Photogrammetric map of print G1-36 at 1 mm contour intervals

LAETOLI PROJECT
1996 FIELD CAMPAIGN REPORT

EXECUTIVE SUMMARY

- The 1995 field campaign to conserve the southern portion of 3.6 million year old hominid trackway at Laetoli, Site G in Tanzania took place from July 3 to September 2. The nine week field season involved re-excavation, conservation, photographic and photogrammetric recording, scientific restudy and reburial of the southern portion of the trackway; surface drainage modifications to the area surrounding the trackway; and making of new molds and casts from existing 1978-79 cast segments of the trackway. Twenty-five members of the joint Getty Conservation Institute (GCI)-Tanzanian team participated in the campaign. The team operated from a tented camp close to the village of Endulen. Additionally, a three-member team, operating under a separate permit from the Antiquities Unit, undertook a palaeoanthropological restudy of the trackway.

- Three areas at the site—part of the Laetoli trackway itself, Test Site 3 close to the trackway, and the head of the NW gully—were vandalized in the spring of 1995. The incident was discovered and reported to the Antiquities Unit and the GCI following a routine site inspection by Godfrey Olle Moita. In all three locations, the lava boulders and the reburial fill underlying the boulders had been disrupted, and the Biobarrier fabric or Enkamat buried in these areas had been removed. This is the second time that the Laetoli trackway and Test Site 3 have been disturbed; both times with the apparent intent of removing the geofabrics. In addition to the vandalism, there was evidence in the form of four puncture marks on the trackway that the disturbed area was probed with a spear.

- Within a 10 x 4.50 m trench established at the southern end of the trackway, the 1995 excavation exposed the 1979 trench and the trackway surface, containing 29 hominid footprints, two hipparion trails, indeterminate carnivore tracks and numerous lagomorph prints. In addition to the 1979 trench walls, excavation revealed several 1979 datum points, the unexcavated Augite Biotite Tuff, and stones blocking the southern exploratory trench and the west trench.

- The 1979 burial fill ranged in depth from a shallow 20 cm in the NE part of the trench to 70 cm at the southern end. This reflected the considerable slope of the trackway surface to the SW, which resulted in the accumulation of moisture in this part of the

excavated area. The 1979 fill consisted of a wide range of particle sizes and gravel. In general, it became more consolidated near the trackway surface, and in the wetter southern end of the trench fill material had embedded in the tuff.

- Within the boundaries of the 1995 trench, 38 acacia trees were inventoried, 5 of which were remnant stumps from 1979. All of the post-1979 acacias had been treated with herbicide in 1994. All acacias were dead (except one which had re-sprouted) when excavated in 1995 and many had been infested with termites. Sixteen of the acacia trees had penetrated the footprint tuff surface, largely in the northern half of the trench, resulting in localized disruption and damage to the tuff and to four hominid prints. Stumps and roots were removed from the tuff wherever possible and voids in the tuff left by extracted roots were filled with a mixture of acrylic dispersion and fumed silica. Remaining stumps and roots were injected with a dilute solution of pentachlorophenol in acetone and isopropyl alcohol to discourage termite activity and prevent fungal rot.

- A dark staining of the tuff in and around the hominid and hipparion tracks was observed and later conclusively identified as the consolidant Bedacryl, which was applied in 1979 to strengthen the tuff prior to molding. The Bedacryl was obscuring some of the finer texture and details in the prints. Its condition was variable: in some prints it was a thin, evenly applied and well adhered layer; in others it was thick, uneven and slightly uplifted or fractured. The consolidant was removed with acetone from only two prints. Further removal was not undertaken since doing so would pose a risk of loss of the underlying tuff layer, and of itself Bedacryl was not causing harm to the footprints.

- All aspects of the campaign were documented in 35mm and medium (2.25 x 2.25 in.) format photography and with informal video recording. Formal photography in both formats was undertaken of individual footprints prior to reburial.

- Photogrammetry was undertaken of the 29 hominid footprints and the hipparion trails. The photogrammetric process involved extensive surveying of the individual footprints and the trackway surface and site datum points to achieve accuracies of all point positions of 0.5 mm or better. Photography was conducted using three different cameras: a metric Zeiss UMK with 5 x 7 in. glass plates, a digital Kodak DCS420, and a Hasselblad (2.25 x 2.25 in.).

- In the on-going effort to control site drainage and thereby reduce surface erosion, a third diversionary berm, located northeast of the trackway, was constructed with lava boulders and a weak cement mortar. As with the two lava boulder berms constructed in 1994, the new berm was designed to divert water away from the NW gully. Examination of the 1994 berms revealed undercutting of berm 2 at its northern end, which was repaired.

- Samples of Footprint Tuff and 1979 burial fill were collected for further analyses and characterization at the GCI; carbide moisture measurements were taken to determine subsurface moisture profiles; soil pH was tested; and samples of local river sands were characterized for use in the reburial.

- Molding and casting activities took place in Dar es Salaam and the Endulen field camp. In Dar es Salaam a cast of the southern portion of the trackway was patinated for museum use. In the field camp, additional polyester casts and silicone rubber molds were made of existing 1978 and 1979 casts stored at Olduvai. An inventory of molds and casts at Olduvai was completed.

- During two weeks of the 1995 season, three palaeoanthropological scientific re-study projects were conducted on the trackway. These involved a morphological description of the hominid prints, microstratigraphical study and mapping of the footprint tuff surface and individual footprints, and a study of functional morphology.

- The trackway was reburied under a composite layering of sieved sands and geosynthetic materials (geotextile, Biobarrier, and Enkamat) to a height of 0.85 - 1.00 m and capped with a layer of lava boulders. In all, some 30 cubic meters of soil was used in the reburial of the trackway. The majority was quarried from the Garusi and Kakesio Rivers and transported to the site by lorry.

- To monitor conditions in the reburial mound in the future, a 2.5 x 2.5 m facsimile trench at Test Site 3 was similarly backfilled and test objects, such as acacia stumps and roots, tuff treated with consolidants, pieces of geotextile and cotton fabric, and ferrous material were placed on the tuff surface. The test trench will provide data on bioturbation, moisture and salt migration, and the efficacy of reburial materials in the buried environment.

- As a means to protect the site and to ensure regular maintenance and monitoring a number of measures were implemented. Two local Maasai guards were permanently posted to the site by the Antiquities Unit and a permanent dwelling was begun for the guards. Meetings were held with Ngorongoro Conservation Area (NCA) officials to discuss the integration of the maintenance and monitoring needs of the Laetoli site into the new General Management Plan for the area. A traditional Maasai ceremony was held to bless the site in order to enhance its significance to the local community.

- The 1995 campaign was successful in achieving its objectives. The 8.50 m of exposed trackway where the best preserved hominid prints were found in 1979 was in good condition despite the intrusion of acacia trees into the 1979 burial mound. The 1995 reburial of the trackway, combined with enhanced security and routine monitoring, should protect the trackway for the long term. In 1996, the remainder of the trackway will be re-excavated and, following now established procedures, conserved, documented and reburied.



I. INTRODUCTION

by Martha Demas and Neville Agnew

BACKGROUND

The 1995 Laetoli field campaign initiated the third phase of activity in the joint Getty Conservation Institute (GCI)—Government of Tanzania project to preserve the hominid footprint trail at Laetoli, Site G, in northern Tanzania. The Pliocene site of Laetoli, which preserves both hominid and faunal tracks, as well as numerous hominid, animal and plant fossils, has immense scientific value, particularly for understanding human evolution. The trackway at Site G, fortuitously preserved within layers of aeolian and airfall volcanic tuff, not only records the diversity of life in the Pliocene savannas of East Africa, but more significantly, offers unique evidence of bipedalism in hominids from 3.6 million years ago. Site G, excavated by Dr. Mary Leakey in 1978-79, was documented and then reburied underneath a mantle of soil and lava boulders. Since the trackway's reburial in 1979, acacia and other vegetation have taken root in the burial fill. A preliminary assessment of the trackway's condition undertaken by a joint Tanzanian-GCI team in July 1992 revealed that acacia roots had penetrated the footprint surface, and had damaged individual hominid prints.

The goals of the Laetoli project, formalized in an Agreement signed by the GCI and the Government of Tanzania in June 1994, are to implement a conservation program for the hominid trackway at Site G, to develop a monitoring and maintenance program for the long-term preservation of the site, and to create museum exhibitions in Tanzania for public education and to raise public awareness about the importance of the Laetoli site. The conservation program involves reburial of the hominid trackway for the long term.

The project entails four phases of activity:

Phase 1 (1993, completed)

Phase 1 involved assessment of condition and conservation potential through partial re-excavation of a 3 x 3m trench over the trackway. This was undertaken in July-August 1993 by a joint Tanzanian-GCI team, operating under a Letter of Intent signed by both parties. The results and recommendations from the assessment campaign are recorded in the **Report on the 1993 Field Season**. The recommendations from the 1993

report (Part XI. Conclusions and Recommendations) formed the basis for planning the conservation work at Laetoli for Phases 2-4.

Phase 2 (1994, completed)

Phase 2 involved mapping the site, treatment of the trees growing on the trackway with herbicides, stabilization measures to control erosion of the site, making a new master mold from the 1979 cast of the trackway stored at Olduvai, and informing the local Maasai elders of the project and enlisting their support for the future protection of the site. This phase was undertaken in two field campaigns during the 1994 calendar year (May and July-August). Results of the field campaigns are detailed in the **Report on the 1994 Field Season**.

Phase 3 (1995-96)

Phase 3 involves two conservation field campaigns over a two-year period; the southern third of the trackway was the focus of the 1995 campaign, with the middle and the northern thirds to follow in July-September 1996. The field campaigns entail re-excavation of the trackway, conservation treatment, documentation of the hominid prints by photogrammetry, scientific re-study, and reburial of the trackway in a manner that will ensure its future protection. Additional molding and casting of the 1979 molds and casts stored at Olduvai will be conducted in 1996.

Phase 4 (1996-97)

Phase 4 will involve development of a maintenance and monitoring program for Laetoli, re-excavation of a portion of the monitoring reburial trench, and creation of museum exhibitions in Tanzania on the Laetoli trackway. Publication of the conservation, documentation and scientific re-study of the trackway will be an on-going activity, beginning in 1996.

OVERVIEW OF THE 1995 FIELD CAMPAIGN

The 1995 field campaign took place over a nine week period, from July 3 to September 2. The purpose of the campaign was to excavate, conserve, document, study, and rebury the southern third of the trackway where 29 hominid footprints and numerous animal tracks were excavated in 1979. Photos 1-8 show the southern trackway in 1979, and in 1995 at significant stages during the campaign.

As mentioned above, the 1995 season was preceded by an assessment campaign in 1993 and a site stabilization and preparation campaign in 1994. Planning for the 1995 campaign also included establishing the Laetoli Consultative Committee (LCC), which met in March 1995 to discuss the conservation program and initiate the process for selecting the palaeoanthropological study team. Members of the Consultative Committee met again in February 1996 to review the results of the 1995 campaign and plan for the 1996 season (see Appendix A for list of LCC members).

Participating in the 1995 campaign were the following team members (see also Appendix B):

Getty Conservation Institute (GCI)

Neville Agnew, Associate Director, Programs, GCI

Francesca Alhaique, PhD candidate, Anthropology Dept., Washington University, St Louis

Angelyn Bass, Research Fellow, GCI

Chester Cain, PhD candidate, Anthropology Dept., Washington University, St Louis

Martha Demas, Project Manager, Special Projects, GCI

Eric Doehne, Associate Scientist, Scientific Program, GCI

Po-Ming Lin, Geotechnical Consultant, Special Projects, GCI

Fiona Marshall, Archaeologist, Anthropology Dept., Washington University, St. Louis

Tom Moon, Scientific Photographer (independent)

Gaetano Palumbo, Documentation Coordinator, Research and Applications, Documentation Program, GCI

Francesca Piqué, Conservation Specialist, Special Projects, GCI

Jerry Podany, Head Conservator, Dept. of Antiquities Conservation, The J. Paul Getty Museum

Heinz Rütger, Head, Dept. of Surveying and Geodetic Engineering, University of Cape Town

Eduardo Sanchez, Assistant Conservator, Dept. of Antiquities Conservation, The J. Paul Getty Museum

Julien Smit, Photogrammetry Assistant, Dept. of Surveying and Geodetic Engineering, University of Cape Town

Ron Street, Manager, Molding Studio, Metropolitan Museum of Art, New York

Tanzania

Joel Bujulu, former Senior Principal Research Officer, Plant Protection Division, Tropical Pesticide Research Institute, Arusha

Donatius Kamamba, Conservation Architect, Antiquities Unit

Ozias Kileo, Archaeologist, Antiquities Unit

Moses Lilombero, Preparator, Casting Unit, National Museum of Tanzania

Ferdinand Mizambwa, Technician and Mason, Antiquities Unit

Godfrey Olle Moita, Conservation Assistant, Olduvai Gorge

Jesuit Temba, Conservator and Preparator, National Museum of Tanzania

Digna Tillya, Conservator, Antiquities Unit

Simon Waane, Director, Antiquities Unit

Palaeoanthropological Study Team

Craig Feibel, Visiting Assistant Professor, Dept. of Anthropology, Rutgers University
Bruce Latimer, Curator, Dept. of Physical Anthropology, Cleveland Museum of Natural
History
Peter Schmid, Professor, Anthropological Institute and Museum, University of Zurich-
Irchel

Field work took place at the site of Laetoli, at the project camp at Endulen (molding and casting) and at the National Museum in Dar es Salaam (molding and casting). The base camp for the project team was set up by Hoopoe Adventure Tours, Arusha, under contract to the GCI, near Endulen village for the duration of the nine week campaign. As during previous campaigns, the Ngorongoro Conservation Area Authority (NCAA), in particular Mr Lazaro Mariki (Western Zone Coordinator), assisted the project team in many ways. The villages of Endulen and Esere, through their official representatives, (Mr Augustine Pakaay Ollonyokye and Mr Saitabau Ole Kereto from Endulen; Mr Isaya Alachaushi and Mr Martin Osokoni from Esere) facilitated the camp and hiring of workmen and askaris for the site, and supported the team's efforts to raise community awareness of the project's activities and the significance of the site.

Summary of project activities and responsibilities

Direction and overall supervision of the 1995 field campaign was provided by Simon Waane, Donatius Kamamba and Ozias Kileo of the Antiquities Unit and Martha Demas and Neville Agnew of the Getty Conservation Institute. During the absence of M. Demas the week of July 22-30, Jerry Podany supervised the GCI team. The field campaign schedule and major areas of responsibilities are presented in Appendices B and C.

Photographic and video documentation was conducted for all project activities for the duration of the campaign. The primary responsibility for photographic and video coverage was Tom Moon's, with additional coverage provided by Neville Agnew, Martha Demas, Angelyn Bass and Francesca Piqué.

The re-excavation of the southern third of the trackway was supervised by Fiona Marshall, assisted by Donatius Kamamba and Martha Demas. The archaeological team comprised Francesca Alhaique and Chester Cain, with additional assistance from Angelyn Bass and Ferdinand Mizambwa. Re-excavation of the trackway surface by the archaeological team took place between July 3-22. Archaeologists and conservators

worked together on the excavation of the individual prints from July 22-28. Chet Cain undertook surveying and mapping of the excavated trench and its features.

The conservation team, comprised of Angelyn Bass, Francesca Piqué, Eduardo Sanchez, Jesuit Temba and Digna Tillya, was led by Jerry Podany. The work of the conservation team (July 17-August 11) included final excavation of the footprints with the archaeologists, recording the condition of the trackway, removal of tree stumps and extraction of roots, infilling of voids left by roots and consolidation of tuff where required, and assessment and removal of Bedacryl resin used in 1979. The stainless steel wire frames used in the condition survey were manufactured by Jim Davies at the GCI.

Photogrammetric recording of the trackway was undertaken from August 7-20 by Heinz Rüther, assisted by Julien Smit, Tom Moon and Gaetano Palumbo. The photogrammetric team also surveyed trench and datum points. The field work and integration of photogrammetric and other data into a GIS is being coordinated by Gaetano Palumbo. Tom Moon supervised the construction of the camera track and the development of the photogrammetric 5x7-inch glass plates in the field.

Po-Ming Lin and Joel Bujulu undertook the assessment of the 1994 treatment of acacia trees with herbicide and additional treatment of acacia trees in 1995. The use of a preservative on stumps and roots left *in situ* in the trackway was done by Neville Agnew and Joel Bujulu.

Site stabilization efforts were undertaken by Neville Agnew, assisted by Po-Ming Lin and Ferdinand Mizambwa.

The scientific study of the trackway was conducted under a separate permit from the Antiquities Unit by Craig Feibel, Rutgers University; Bruce Latimer, Cleveland Museum of Natural History; and Peter Schmid, Zurich University, from August 7-20.

Reburial of the excavated portion of the trackway and the monitoring trench took place from August 23-29. The reburial of the trackway and installation of the reburial monitoring trench (Test Site 3) was supervised by Martha Demas and Neville Agnew, assisted by Angelyn Bass, Po-Ming Lin, Chet Cain, Simon Waane, Ferdinand Mizambwa, and Godfrey Olle Moita. Po-Ming Lin, Godfrey Olle Moita and Ferdinand

Mizambwa supervised the extraction, transportation and sieving of all reburial materials.

Community relations and arrangements for the consecration ceremony were handled by Simon Waane and Godfrey Olle Moita.

Molding and casting work was undertaken in Dar es Salaam and at Endulen camp from July 3-23. The work was supervised by Ron Street, assisted by Jesuit Temba and Moses Lilombero.

On-site sampling, sub-surface moisture monitoring, and geochemical lab analyses and tests were conducted by Eric Doehne in the GCI laboratory, and on site with Neville Agnew during the week of July 17. Herant Khanjian undertook infrared spectral analysis of a Bedacryl sample at the GCI.

Four workman from the village of Endulen--Josefat Nachan, Sangale Keriko, Peter Koromo, and David Seyai--assisted the team throughout the campaign.

Visitors to the site

Over several weekends of the 1995 season the site was open to public visitation. Among those who visited were school teachers from the locality, personnel from the Endulen Mission Hospital, members of the expedition working at Olduvai, staff from the Serengeti Wildlife Research Center, and two Tanzanian journalists (Mr Mohamed Ugasa Rashid from the *Business Times Weekly*; Mr Masoud Masoud from the *Guardian*). A National Geographic team (Rick Gore, Chris Sloan, and Ken Garrett) photographed the trackway under separate permit from the Antiquities Unit. A number of NCA staff paid visits to the site during the course of the campaign, including Mr Dawas (Assistant Conservator), Mr Mjema (Assistant Superintendent of Police), Mr Asantele Melita (Research and Planning Unit), and Mr Paul Mshanga (Chief Manager, Tourism Dept.).

Visiting from the Ministry of Education and Culture were the Principal Secretary (Mr A.M. Vuai), Deputy Principal Secretary (Mrs Malawi), legal counsel (Mrs Susan Mlawi), Commissioner of Culture (Dr Daniel Ndagala), and the Regional Cultural Officer from Arusha (Mr Mamboleo); from the GCI were the Director (Mr Miguel Angel Corzo), Program Research Associate (Dr Mahasti Afshar), and Special Projects Director

(Mr Giora Solar). Dr Mam Biram Joof, Unesco representative and member of the Laetoli Consultative Committee, also visited the site.

Of special significance to the team was the two-day visit by Mary Leakey to the site. Peter Jones also visited the site at this time. Both generously shared their knowledge of the site with team members.

Site set-up

Two tents were set up along the eastern escarpment of Site G for use by the site guards and for storage of tools, equipment and materials used during the campaign. During the second week of excavation, prior to exposure of the footprint tuff surface, a temporary shelter was erected over the excavated portion of the trackway. The shelter remained over the trackway until reburial, except for periodic removal for unimpeded photography of the trackway.

TERMINOLOGY USED IN THIS REPORT

In order to provide consistency and clarity in the use of terminology throughout this report, the following descriptive terms for tuffs, soils and excavated horizons are defined with reference to their use and meaning in the report. Where applicable, these follow the definitions originally established by R. Hay, adapted specifically to Site G and the hominid trackway by C. Feibel in his more recent work.

- **Black Cotton Soil**: This is the name given to the endemic, heavy, clay-rich, black soil in the Laetoli area. At Site G it occurs principally on the eastern side where it forms an escarpment. Presumably, it derives, as a weathering product, from a younger volcanic deposit.
- **Augite Biotite Tuff**: This represents the "culmination of the eruptive sequence recorded by the Footprint Tuff" (Hay in Leakey and Harris 1987, 36), deposited above the Upper Unit of the Footprint Tuff (see below). The Augite Biotite tuff was not excavated in 1979 at the extreme southern end of the trench and remains as an irregularly-shaped area approximately 2 m x 0.60 - 1.30 m (Photo 6; Fig. 5). In this report, the term is used on plans and sections and descriptively in the archaeological and conservation reports to refer to the unexcavated matrix above Horizon B of the Footprint Tuff. In such usage, the term Augite Biotite may include the Upper Unit of the Footprint Tuff, which however, was not always

clearly distinguishable in the weathered profiles (it is provisionally identified as the tuff layer that was left unexcavated in 1979 in the west trench (Photo 6 and Fig. 5). According to the Laetoli monograph, the edge of the Augite Biotite defines a small fault, which truncates print G2/3-31 (Leakey and Harris 1987, p. 490).

- Footprint Tuff: The approximately 15 cm thick layer of volcanic tuff, comprising an Upper Unit (4-6 cm thick), subdivided into 4 units or layers; and a Lower Unit (7-10 cm thick), subdivided into 14 units or layers. Each sub-unit or layer represents an ashfall from a single eruption. The hominid tracks at Site G were formed in the uppermost layer (layer 14) of the Lower Unit, which marks the transition between the Lower and Upper Units. The term Footprint Tuff is always capitalized when referring to this geological unit or part thereof.

- Horizon B: This marks the surface of layer 14 of the Lower Unit of the Footprint Tuff, in which the hominid tracks were formed (Photos 1, 6). Horizon B is more commonly referred to in this report as the (hominid) "footprint surface" or even more generically as the "tuff or trackway surface." In practice, excavation in 1979 to a single microlevel of the Footprint Tuff could not be consistently achieved. Thus, the footprint surface or Horizon B as excavated in 1979 and re-excavated in 1995 shows evidence of remnants of Footprint Tuff layers other than layer 14, particularly of the lowest lamina of the Upper Unit Footprint Tuff.

- Calcite layer: A secondary deposit of calcite (approximately 1 mm maximum thickness) lines many of the footprints in the well preserved part of the trackway. It is discontinuous and does not extend uniformly over Horizon B. The calcite precipitated from ground water after the footprints were buried by subsequent ashfalls.

- Well preserved tuff: This comprises the largest area with the greatest number of hominid prints (22 prints) of the southern trackway, extending from the unexcavated Augite Biotite in the south to the "weathered tuff" (see below) in the north (Photos 1, 6). The tuff here is well cemented with calcite and was sufficiently covered by a mantle of original overburden to protect it from weathering. This tuff surface is also referred to as the "unweathered tuff" and the "calcite-cemented tuff" in this report.

- Weathered tuff: This refers to a strip of tuff at Horizon B, approximately 1.40 - 1.90 m wide, near the northern end of the excavated trench where the Footprint Tuff was very close to the surface in 1979 and had consequently been subjected to weathering and soil formation (Photos 6, 12). In appearance, it is darker than the well-preserved tuff with distinctive polygonal cracking. A few small islands or patches of calcite cemented tuff still exist as remnants close to the southern limit of this weathered zone. Six poorly preserved hominid prints were excavated in this section in 1979.
- Lower Unit tuff: The Lower Unit Tuff seems to be represented in the northernmost area of trackway re-excavated in 1995, immediately north of the weathered tuff (Photo 12). The exposed tuff in this area represents a tuff layer below Horizon B. One shallow, amorphous depression in the surface of this tuff has been interpreted as representing the heel of a hominid footprint (tentatively identified as G2/3-23), transmitted as a "ghost" from the previously overlying stratum of Horizon B.
- Clayey stratum: This refers to the deposit of aeolian tuff underlying the Footprint Tuff. It is clearly visible and eroding out below the Footprint Tuff in the NW gully. This is also the stratum in which the monitoring trench at Test Site 3 is excavated.

RE-LOCATION AND NUMBERING OF HOMINID AND ANIMAL PRINTS

Hominid Prints

There are 29 numbered hominid prints in the southern trackway (Fig. 5). The first prints of the G1 and G2/3 trails in the southern section were found in an exploratory trench in 1978 and were given the numbers G1-25 and G2/3-18 respectively following from the sequence of prints in the northern trackway. Since each footprint was given a number as it was excavated, the sequence of discovery and excavation can be followed. Thus, G1-25, 26 and 27 and G2/3-18, 19, and 20 were discovered in 1978. In 1979 excavation began to the north of G1-25 and G2/3-18, revealing prints G1-28, 29, 30 and G2/3-21, 22, 23, at which point the trails are completely eroded. Excavation then resumed south of G1-27 and G2/3-20 in a continuous sequence through G1-39 and G2/3-31.

Identification of the footprints in 1995 was aided by the photogrammetric plan of the southern trail (from the 1987 Laetoli monograph), which records 23 of the footprints and their numbers. In addition, numbers of each print had been inscribed on the tuff in 1979 with black ink and these were still visible in most cases. Even those prints with little or no morphology (G1-32, G2/3-22) could be re-located using existing documentation. There remains some confusion, however, about the identity of prints G2/3-22 and 23. The description of print G2/3-22 in Leakey and Harris 1987 corresponds to the location and physical characteristics of G2/3-23; while the description of G2/3-23, as lying "north of the main transverse fault" suggests a location further north. We have retained the numbering indicated on the plan published in Day 1986, Fig. 64 (see Fig. 13 in this report) anticipating that excavation of the prints to the north may clarify the discrepancy. At present, print G2/3-23 can only be defined as a shallow amorphous depression with no associated number marked on the tuff to confirm its location.

Animal Prints

The two hipparion trails in the southern trackway were designated Trackways B and C in Leakey and Harris 1987, 471ff, and numbered from 1-13 and 1-12 respectively. This numbering system has been retained on the plan in Fig. 5, and two tracks at the southern end of the C trail, which were not indicated on the 1987 plan, were added to the 1995 plan (nos C13 and 14). It should be noted that the orientation of the schematic plan of the hipparion tracks published in Leakey and Harris 1987 (as Fig. 12.17) is reversed. The beginning of the sequence (B1 and C1) is at the northern end of the trail, not the south as indicated in Fig. 12.17.

Indeterminate carnivore and numerous lagomorph tracks were identified on the southern trackway in 1979 (Leakey and Harris 1987, 457). Many of these have been captured in the 1995 photogrammetric survey, but have not been numbered. The probable carnivore tracks are indicated on the plan (Fig. 5).

A NOTE ON THE PLANS AND SECTIONS

The general plan of the site (Fig. 1) is based on the plan drawn by MMG Surveyors, Arusha, in 1994, and amended by C. Cain in 1995; it was produced on Freehand software by Ken Niles (*Ad Infinitum*, Los Angeles). Final sections (A, B, C, D) and the schematic plan (Fig. 2) were produced from 1995 field plans on Freehand software by Jim Railey (Washington University) under the supervision of F. Marshall

and C. Cain, with subsequent editing by J. Chase Langford (University of California, Los Angeles). The plans in Figures 5 and 6 were drawn by Antoinette Padgett (University of California, Santa Barbara) using a base plan produced from the photogrammetric contour mapping and survey data as well as the field plans, under the supervision of M. Demas and A. Bass. The photogrammetric plan (Fig. 7) was produced by Heinz R  ther from the digital terrain models using a variety of software and transported into AutoCAD for final output by Gaetano Palumbo; A. Padgett drew trench lines and other features for Fig. 7.

Acknowledgments

The contributions of Cynthia Godlewski and Helen Mauchi in the preparation of this report are gratefully acknowledged.



MEMBERS OF THE LAETOLI CONSULTATIVE COMMITTEE

- Dr. Neville Agnew, Associate Director, Programs, Getty Conservation Institute
Dr. Desmond Clark, Professor Emeritus, Dept. of Anthropology, University of California, Berkeley
Dr. Martha Demas, Project Manager, Special Projects, Getty Conservation Institute
Dr. Mam Biram Joof, Regional Representative, UNESCO
Mr. Donatius Kamamba, Architectural Conservator, Antiquities Unit
Dr. Mary Leakey, Archaeologist, Kenya
Mr. F. Mkunyi, Acting Chief Manager, Management of Natural Resources Department, NCAA
Dr. Daniel Ndagala, Commissioner of Culture, Ministry of Education and Culture
Mr. Webber Ndoro, University of Zimbabwe, Zimbabwe
Dr. David Pilbeam, Dept. of Anthropology, Harvard University
Mr. Victor Runyoro, Senior Ecologist, Ngorongoro Conservation Area Authority
Dr. Simon Waane, Director, Antiquities Unit

1995 LAETOLI PROJECT CAMPAIGN PARTICIPANTS

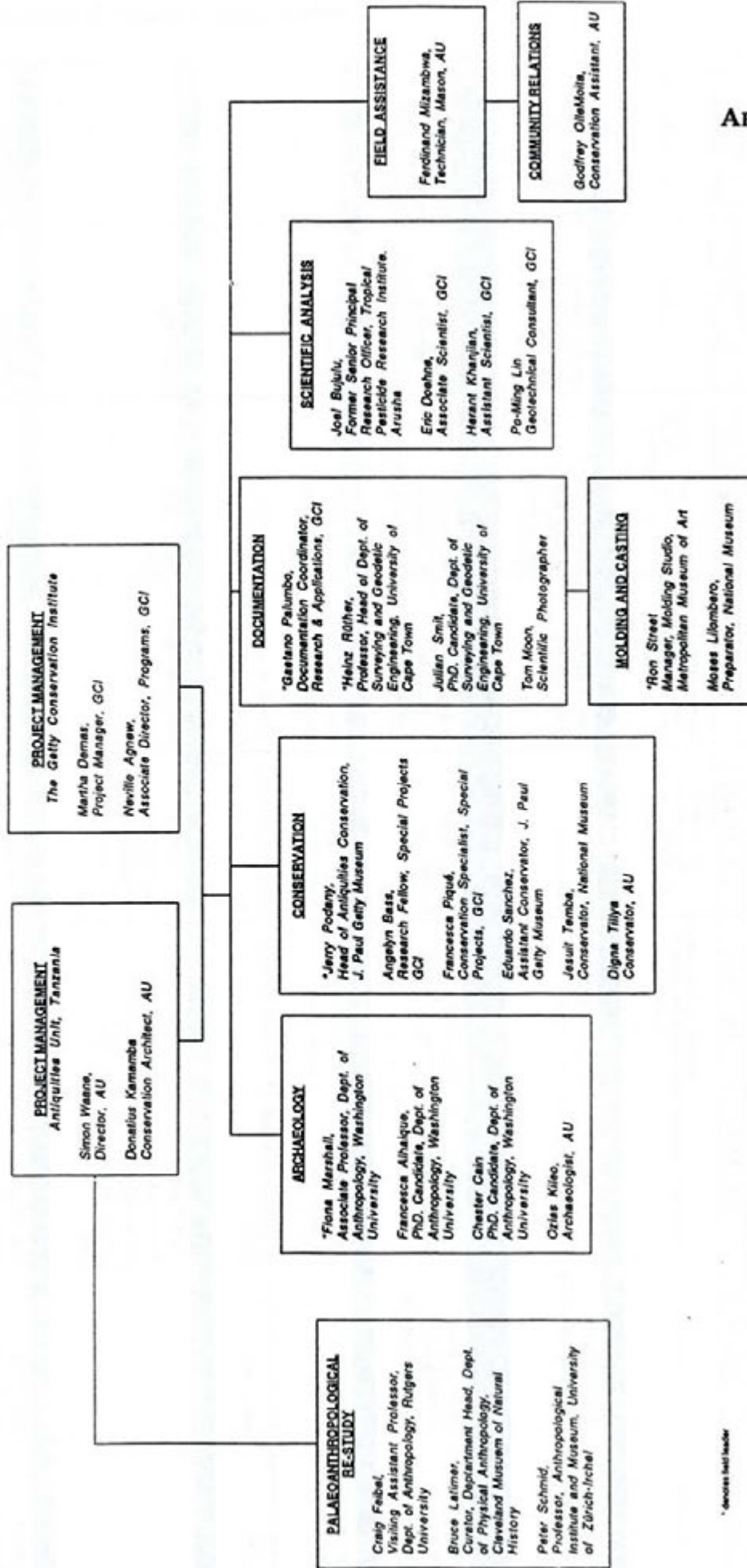

* denotes field leader

PART II. RE-EXCAVATION OF THE TRACKWAY

by Fiona Marshall

INTRODUCTION

The aim of the 1995 excavation was to expose the southern portion of the trackway at Site G, in order for conservation, documentation and scientific re-study of the trackway to be undertaken. Subsidiary aims of the archaeological team were to map the position of the 1995 trench relative to the site as a whole, to establish a grid system for documentation within the excavated area, and to assist in the final reburial of the site.

Re-excavation took place under the direction of Fiona Marshall, assisted by Donatius Kamamba, from the Tanzanian Antiquities Unit, and Martha Demas of the GCI. The archaeological team comprised Francesca Alhaique and Chester Cain, with additional assistance from Angelyn Bass of the GCI and Ferdinand Mizambwa of the Antiquities Unit.

SCHEDULE OF ACTIVITIES

Work began at the site on July 3, 1995 with photographic documentation of the site by Tom Moon, mapping the disturbed area (see Part III), and discussions on the strategy for excavation and the siting of boulder piles, backdirt piles and sieving areas for reburial. On July 4 and 5 the tarps for the backdirt were laid out south of Test Site 3 (Fig. 1), the trackway and adjacent areas were cleared of grasses and weeds, the mantling layer of boulders on the mound was removed, and the new trench and grid system for the southern section of the site was set up. Re-excavation of the 1979 reburial fill and exposure of the footprint tuff took place between July 5 and July 22. Re-excavation of the individual prints was done in conjunction with conservators between July 22 and July 28. Surveying of the trench and of the site in general occurred at intervals throughout the season.

SURVEY OF THE 1995 TRENCH AND RELOCATION OF THE 1979 TRENCH

Siting of the 1995 trench was hampered by not having any maps of the 1979 trench tied into a site datum. It was necessary, therefore, to rely heavily on the general configuration of the 1979 reburial mound to establish the position of the 1995 trench, and to modify trench boundaries as excavation progressed. The intent was to establish 3 trenches in 1995, covering 9 m, and including all 29 of the southern hominid prints.

From south to north, the trenches were designated Trench 1, 2, and 3, respectively. They were each initially 3 m (N-S) x 4 m (E-W), later enlarged to cover a total area of 10 m (N-S) x 4.5 m (E-W) in order to encompass the southern end of the 1979 mound and the eastern boundary of the 1979 trench (Fig. 2). Trench 2 was intended to coincide with the 1993 assessment trench. Following the grid system established in 1993, the NW corner of Trench 2 was designated 100/100, increasing to the N and the E (see Appendix A, **1995 Grid and Datum Points** for details).

The SE corner of the 1993 test trench was easily relocated by the distinctive double stump, # 13, which marked it; the NW corner nail was also located during re-excavation. The N-S orientation of the 1995 trenches was changed by approximately 6 degrees from the 1993 trench to align better with the burial mound, resulting in a slight adjustment of the 100/100 point (see Fig. 2, and Appendix A)

The co-ordinates and dimensions of the final 1995 trenches are as follows (Fig. 2):

Trench 1: 4 x 4.50 m

Co-ordinates of corners of trench: SW corner: E100/N93, NW corner: E100/N97, NE corner: E104.5/N97, SE corner: E104.5/N93.

A balk was surveyed in E-W across the trench from N96.50 to N97.

Trench 2: 3 x 4.50 m

Co-ordinates of the corners of the trench: SW corner: E100/N97, NW corner: E100/N100, NE corner: E104.5/N100, SE corner: E104.5/N97.

A balk was surveyed in E-W across the trench from N99.50 to N100

Trench 3: 3 x 4.50 m

Co-ordinates of corners of the trench: SW corner: E100/N100, NW corner: E100/N103, NE corner: E104.5 /N103, SE corner: E104.5/N100.

Before excavation began, the N-S profile of the 1979 reburial mound was mapped (Fig. 9), and the 1995 trench and two 1979 concrete datum points outside the burial mound were surveyed. These datum points are referred to on the maps as "S" point and "E2" (Fig. 4). "S" point (E98.70/N86.95) was used as the site datum, archaeology elevation zero. When surveyed into the elevation system used by MMG surveyors in drawing the general plan of Site G in 1994 (Fig. 1), this falls at 51.72 m. A

third 1979 datum point ("W2") was located after full clearing of vegetation and others were established during the 1995 season (see Fig. 4 and Appendix A for location and details).

CHARACTERISTICS OF THE 1979 REBURIAL FILL AND METHODS OF EXCAVATION

The depth of the 1979 reburial fill ranged from a minimum of 20 cm at the northeastern end of the excavated trackway to a maximum of 70 cm at its southern end, reflecting the slope of the trackway to the SW (Fig. 9). There was much variation in the size of the fill matrix, which ranged from pebbles as large as 5-8 cm in maximum dimension, to fine sands usually present in a very thin layer (approximately 3 mm) at the footprint surface. The fill also contained quite a number of fossils, the largest of which was a bovid upper molar, 2.5 cm in maximum dimension.

In general, the 1979 reburial fill became more consolidated with depth, but it was very patchy, tending to be harder in the south than in the north of the trench, and wetter on the west than the east. In parts of the trench the fill was so consolidated that it excavated like stone, and was considerably harder than the unexcavated matrix comprising the edges of the 1979 trench. It seems likely that this is the result of the migration of soluble salts and clay particles leached from the 1979 reburial overburden to the relatively impermeable tuff surface, where precipitation and consolidation occurred (see also Part XII).

In one area only of the trench, approximately 25 cm sq, around E103/N96.50, the 1979 fill was not at all consolidated and could be simply brushed away from the tuff surface. This section of the trackway was noticeably dry with very few fine sand particles and many acacia roots.

Excavation of the first several spits below the surface of the mound was done by shovel shaving for one or two spits of approximately 10 cm each. The bulk of the excavation was conducted using trowels with dustpans and brushes (Photo 10). "Olduvai tools" (5 inch nails hammered to form a chisel end, and mounted in a wooden handle) were made on site (by Ferdinand Mizambwa) in order to excavate areas of consolidated fill more effectively. Small quantities of water were also applied from dropper bottles to soften very consolidated areas of fill. This proved effective, immediately loosening the bonds between particles of fill. However, this technique was not used in close proximity to the tuff surface because of the softening effect that water

has on the tuff. For exposure of the well preserved tuff surface, Olduvai tools and trowels gripped towards the point and positioned on their sides (Photo 10), were mostly used in such a way that they applied pressure to pebbles overlying the tuff to flick them off without scraping the tuff surface. Where the tuff surface was damp along the western and southernmost parts of the trackway, it was left to dry somewhat and wooden tools were used in the same general way. These included tongue depressors shaped to a blunt point and shaped applicator sticks. This technique in conjunction with a greater reliance on the use of brushes was also used for excavation of the weathered tuff section near the north end of the trench.

Excavation of the layer of fine sand in Trench 2, which had been used to rebury the trackway in 1993, was very easy. In most cases the material could be simply brushed away. At the base of deeper features such as prints it was slightly more consolidated, but could still be easily removed with wooden tools.

Individual footprints were excavated by conservators working with the archaeologists. Shaped wooden tongue depressors, applicators sticks and medium-fine, and fine brushes were used (Photo 14). As with the general tuff surface, pressure applied to individual pebbles caused them to be released from the surface of the print in most cases. The presence of a layer of Bedacryl[®] within the prints (see Part IV for description of the Bedacryl layer) obviated the intended use of acetone (Bedacryl is soluble in acetone) to allow visual contrast between the fill and Horizon B in the base of the prints—a technique developed by Tim White in 1978 using lacquer thinner. After excavation of the tuff surface and prints, fine cleaning was conducted by conservators using magnifying loops, brushes and small wooden tools.

To prevent abrasion of the tuff by continued brushing, a low-powered vacuum cleaner, with blowing capabilities, was used to keep the trackway clean during later stages of work.

During excavation of the footprints, a field cast of the southern trackway (replicated from the 1979 cast) was a most valuable guide. This was cut into smaller segments for ease of use on the trackway (Photo 14). A portfolio of each footprint containing 1979 color photographs by John Reader, enlarged 1:1 B&W 1979 photos by Peter Jones, and published information about the prints was also consulted during the excavation.

To protect the exposed tuff surface from direct sun, a custom-made shelter was placed over the excavated trackway during the field season (Photos 9, 35). The steel frame was covered with white translucent nylon and the sides were provided with roll-up panels of open-weave synthetic textile. When overall photography of the trackway was needed, the shelter was easily moved.

EXCAVATION OF TRENCHES 1, 2, AND 3

As described in Part III of this report, Trench 2 (i.e., the 1993 assessment trench) had been disturbed prior to the field campaign by as much as 30 cm below the surface of the mound (Photo 3; Fig. 9). It was therefore decided to begin excavation on Trench 1. On commencing excavation a second layer of lava boulders covering the mound and embedded in the gravel fill of the mound was discovered. Once the boulders were removed, shovels were used to shave off the top 3 spits, a total of about 20-30 cm (Photo 4). The first levels close to the surface of the mound were very compacted and matted together with grass roots. Spits 2 and 3 were less compacted but numerous roots of weeds and acacia occurred at these levels. Lateral acacia roots begin appearing approximately 20 cm below the surface of the burial mound and became more extensive some 40 cm below the surface (Photos 4, 9).

After photographing and plotting the boundaries of the disturbance to Trench 2, the corners and sides of the trench were excavated down to the lowest level of disturbance, approximately 30 cm below the level of the reburial mound. Trowels were used to take off a further 5 cm spit in both Trenches 1 and 2, watching closely for the appearance of the 1979 trench walls. About 25 cm below the reburial mound surface, a fragment of geotextile from the 1992 reburial, which had remained *in situ* in the 1993 north trench wall (see 1993 Report), was exposed along the north edge of Trench 2. In the NE corner, at about 50 cm below the surface, above the layer of fine sand that was used in the 1993 reburial, a second piece of geotextile was found, marking the small trench that Martha Demas excavated to explore the disturbance to this area in 1994 (see Part III and 1994 Report).

Once Trenches 1 and 2 were excavated to the last spit before the tuff level, excavation started in Trench 3. From examination of the footprint tuff exposed outside the 1995 trench to the west (Fig. 1), it was estimated that there was at least 30 cm of fill overlying the tuff surface. Excavation started with shovels, but the tuff was exposed

unexpectedly in spit 2, in the NE corner of the trench, only 20 cm below the surface (Fig. 8). The reason became apparent later when the dip of the tuff surface to the west was revealed.

Small fragments of plastic were found in all three trenches, principally along the western boundary but also within the reburial overburden above the excavated 1979 trench. These were either a yellow or a clear plastic, usually smaller than 1 cm sq., but including larger fragments of up to 8 cm in maximum dimension. A few fragments of a black plastic were also found. The clear plastic was very weathered and degraded; the fragments of heavier yellow plastic showed no signs of weathering. These may be the remnants of the layers of plastic reported to have been put into the trench during reburial in 1979 (Leakey and Harris 1987, p. 553). There was no indication that the mound had been disturbed to remove plastic after the 1979 reburial, but these scraps of plastic were the only evidence found of plastic sheeting.

The 50 cm balks separating Trenches 1 and 2 and Trenches 2 and 3 (Photo 4) were removed prior to excavation of the final fill layer above the tuff (Photo 9), since they revealed very few features and did not add to our understanding of the 1979 reburial.

EXPOSURE OF 1979 TRENCH WALLS AND FEATURES

By the end of the second spit below the disturbance in Trench 2; that is, about 43 cm below the surface of the mound, the boundary of the 1979 trench and ground surface was found on the west side. At E101.34/N96.02 a 1979 marker nail (Leakey Nail 1) set in concrete was located (Fig. 4). After exposure of the west trench boundary, it was revealed that much of the 1979 land surface in the 1.20m wide area between the 1995 west trench line and the 1979 west trench line was composed of cobbles and some boulders, with a mixture of soil, clay material and tuffaceous chunks (probably of Augite Biotite tuff removed during excavation) (Photos 6, 10, 12). This cobble fill appears to represent the filling in of the 1978 exploratory trench, which was oriented N-S and situated just to the west of the 1979 trench (Photo 11). It was here in a further extension of this exploratory trench to the east that the southern footprints were discovered in 1978 (in the area of prints G1-25, 26, 27 and G2/3-18, 19, 20).

In 1979 the team established their trench in line with the 1978 extension trench to follow the trail of the footprints, but at sufficient distance to the east of the N-S

exploratory trench to leave an island (perhaps 50 cm wide) of original unexcavated matrix that formed the western boundary of the 1979 trench. Where the original matrix was excavated in the eastern extension trench, the cobble fill actually formed the western trench boundary. Thus, the west trench boundary between N97.87 - N99.33 is composed of 1978 fill, not original overburden.

The remnant southern edge of the 1978 eastern extension trench can be seen clearly at approximately N97.87-99.33 where the cobbles were partially re-excavated in 1995 to reveal a trench edge (Photo 6; Fig. 5). This feature is clearly visible in 1979 photographs and is indicated on published plans (Leakey and Harris 1987, Fig.13.2; Day 1986, Fig. 64) (Figs. 12, 13 in this report).

Part of this cobble fill may also have been created or augmented in 1979 to build up the edges of the trench in order to contain burial fill within the shallow trench boundaries in the north half of the trench. This was particularly evident north of the 1978 trench edge where the original overburden was very shallow. A similar use of cobbles or tuffaceous fill was noted along parts of the eastern boundary as well, including in the southern part of the trench where the fill partly covered the well preserved 1979 land surface (Photos 6, 9; Figs. 5, 10).

Once the 1979 western boundary was defined, the position of the 1979 east trench wall could be easily determined. Since its position lay east of the initial 1995 trench boundary, the 1995 trench line was extended an extra half meter to the east. At E104.35/N95.79 a second 1979 nail (Leakey Nail 2) was found, defining the SE corner of the main body of the 1979 trench. South of this point, the trench line is stepped to the west (Fig. 5). The eastern trench wall is interrupted for a meter at N98.29-99.29, where it appears that another exploratory trench from 1979 was opened to the east (designated as the 1979 east trench on plans and sections in this report).

At the south end of Trench 1 the area of unexcavated Augite Biotite tuff was defined, and this and the walls of the 1979 trench were very clear (Photo 6; Fig. 5). In the southwesternmost corner of the 1979 trench (E100.86/N93.72) a third 1979 trench corner nail (Leakey Nail 3) was found lying on its side and mostly rusted away. Two stones tied with nylon twine were also found on the 1979 ground surface at the southern end of the excavated trench (Fig. 5); these were left *in situ*.

At the south end of the 1979 trench there are two features defined by a line of stones. One line of stones, at approximately E101.85-102.85, blocks the 1979 southern exploratory trench (Photo 6; Fig. 5). These stones and the fill of the trench were recorded, but otherwise left *in situ* and not excavated in 1995. The other blocking stones were exposed immediately south of Leakey Nail 1. These stones formed the eastern limit of a poorly delineated trench (0.55 m wide) running NW-SE (designated the 1979 west trench) and filled with medium to large stones, clayey soil and fragments of tuff (Photo 5; Fig. 6). This feature was re-excavated in 1995 in order to assist in the drainage of the trackway (see Part XIV). The original, presumably 1979, excavation of this feature had stopped at what appears to be the Upper Unit of the Footprint Tuff, which lies not more than 4.5 cm above the hominid footprint surface at this point (Photo 6).

Mary Leakey and Peter Jones were asked about these features during their visit to the site on Aug. 10. Neither could remember anything about the purpose of the west trench (nor is this feature seen on 1979 photographs). However the southern extension trench was easily recalled, and is mentioned in the Laetoli monograph (Leakey and Harris 1987, 490-91). Peter Jones confirmed that in the southern exploratory trench they were attempting to follow the Augite Biotite tuff to determine its southerly extent. The Augite Biotite disappeared just south of the main trench despite extensive horizontal (to the south) and vertical excavation. It is therefore assumed that the Footprint Tuff was uplifted in the area south of the 1979 trench through faulting and subsequently eroded away. The Footprint Tuff may still be present in the hill south of the site, but exploratory work in 1979 was hindered by the heavy vegetation and the large quantity of overburden that would need to be removed.

In summary, the boundaries of the 1979 excavation, as revealed within the 1995 trench, varied in depth, composition and configuration. The 1995 trench is 10.00 x 4.50 m, established to encompass the 1979 trench and reburial mound. The 1979 trench is 3 m wide for most of its length. In the SE part of the trench, however, from Leakey Nail 2 southwards, the 1979 east trench wall is stepped to the west; on the west, the southern 1 m of the trench was extended 50 cm further west (Photo 6; Fig. 5). In the northern half, the 1979 east trench wall is very shallow (2-3 cm maximum depth). From N98.29 it increases to the south where it rises to a maximum depth of 28 cm (Fig. 10). The 1979 west trench wall is also very shallow (or missing where it was excavated in 1978) in the north part of the trench, but was augmented by the cobble fill. From N97.87 southwards,

the depth of the west trench wall, which is original unexcavated overburden, has a maximum depth of 27 cm.

EXPOSURE OF THE FOOTPRINT TUFF SURFACE

Martha Demas and Fiona Marshall began exposing the tuff surface at approximately N98 in Trench 2 (Photo 10), in an area where the tuff looked very well preserved, based on the 1979 Reader photographs. A small transect was excavated across the trench from E-W, so that this could then be followed out to the south. It was in the excavated transect that the E-W dip of the tuff surface of approximately 17 cm was first recognized. Where the tuff was most deeply buried in the south and west it was wet. In these areas it was necessary to stop excavation to allow the tuff to dry before proceeding, because the surface was vulnerable to damage. Once the tuff had dried it hardened considerably, and became amenable to further cleaning through the modified troweling method described earlier.

Small linear patches of silicone rubber, representing remnant traces of the 1979 molding of the trackway, were revealed during excavation of the tuff surface in a number of areas. This was useful since it showed that the tuff surface had not deteriorated since 1979, and additionally served as an indicator of the 1979 level. The tuff surface was relatively easy to follow since the fill matrix--typically small pebbles (0.5 cm in size) and, at the finest, black sand--was quite distinct by size, color and texture from the tuff surface. In a few cases where tuffaceous or clay pellets were found in the fill, and mimicked particles of footprint tuff surface, they were left unexcavated until it was clear where the tuff surface was in adjacent areas. In addition, small rootlets were typically distinguishable just above the tuff surface and followed it laterally, forming a marker surface. In most cases the fill material released fairly readily from the tuff surface. However, in some areas, particularly at the wetter south end of the trench, fill material had embedded into the tuff surface and could not be released without damage to the tuff. In these cases the fill was left unexcavated. However after several days, it was often possible to brush further material out of the tuff surface as it dried.

Dip of the footprint tuff

It has not been well documented that the footprint tuff as exposed in the southern portion of the hominid trail dips significantly in several directions. On completion of excavation of the footprint tuff surface in 1995, levels were taken of the tuff surface within the 1979 trench. The tuff surface dips from N to S, and E to W. The

N-S dip, measured at E102, is approximately 30 cm over 8.6 m, that is, from the north end of Trench 3 at 103 N, to the southernmost footprint tuff surface at the boundary with the unexcavated Augite Biotite tuff. The E-W dip varies from 3.8 cm over 3 m at the north end of the 1995 trench, to 21 cm over 1.9 m at the southernmost end of the trackway. The strike and dip of the trackway are defined in Part XII.

This dipping does not, of course, reflect the configuration of the original land surface on which the hominids walked, but was created through subsequent faulting, and lateral displacement and uplift of the footprint tuff. It accounts for the accumulation of moisture in the SW corner of the trench.

GENERAL DESCRIPTION AND CONDITION OF THE FOOTPRINT TUFF SURFACE

When the footprint tuff surface was damp or wet considerable color differences could be seen between different microlevels. Three of these were easily distinguishable: an upper gray level (layer 1 of the Upper Unit), an opaque white level, with several variants (the calcite layer), and the buff surface of the majority of the tuff (layer 14, Lower Unit). When wet, the gray level was especially soft with a clay-like texture. This material was present in small patches on the tuff surface, and appears in the Reader 1979 photographs of the trackway as especially flat and reflective surfaces (Photo 1). It is also present in several unexcavated lagomorph prints on the trackway. The footprint tuff was especially well preserved in the central portion of Trench 2, from about N96.5 -N99. This is also the section of trackway that Peter Jones described as being easier to excavate, since the contact between the Upper Unit Footprint Tuff and the Lower Unit Footprint Tuff was somewhat weathered, and the tuffs easy to separate.

The 1979 fill in the southern portion of the trackway, from about N96.5 southward, was very damp during excavation. As a result, the condition of the tuff surface was poorer in the south than that of the drier tuff to the north, and exhibited less sharpness of detail. There were many small cracks, with pebbles embedded in the tuff in some places, and when dry the tuff surface tended to be somewhat powdery and friable. It is interesting that this is the section of the trackway that Peter Jones said was the most difficult part of the southern trackway to excavate, because the Upper Unit Footprint Tuff adhered quite strongly to the Lower Unit Footprint Tuff. This is reflected in the incidence of 1979 tool marks visible on the tuff surface in the area.

To the north, between N99 and 101, the tuff surface was very poorly preserved in 1979; this is the area referred to as the weathered tuff (Photo 12; Fig. 5). Along its southern edge, there is a marked but nevertheless graduated transition between the well preserved and cemented tuff further south and this very weathered strip. The northern edge of this area, however, is marked by a more abrupt transition to a tuff layer at the northern end of the trench (N101-103). The 6 footprints (G1-29, 30, 31, 32, and G2/3-21, 22) in the weathered tuff were very poorly preserved, two of which (G2/3-22 and G1-32) retain little or no morphology. The weathered tuff was also more severely impacted by growth of acacia roots into the tuff than elsewhere on the southern trackway. It was here that prints were penetrated by tap and lateral roots (see Part V).

While the transition between the well preserved tuff and the weathered tuff appears to be the result of natural weathering of the tuff to soil where it was covered by only 2-3 cm of overburden, the transition along its northern edge is more abrupt (Photo 20). It seems probable that this area of tuff, lying just below the original ground surface, had weathered to soil so completely that the trackway surface could not be identified and was indistinguishable from the overburden. The tuff exposed to the north of the weathered tuff may represent a tuff layer underlying layer 14. A shallow depression in this tuff surface has been identified as a possible footprint (G2/3-23) (see also discussion in Part I).

ROOTS AND VEGETATION

Tree stumps and roots that were exposed by excavation were left in place until excavation had been completed, in order to document the full extent of growth in the reburial fill and in the tuff (Photo 5; see Part V for a full description of trees and other vegetation). As a consequence, in the southern portion of the trench especially, the movement of those working on the trackway was constrained by a network of crisscrossing roots. Lateral roots running across the southern portion of the trench from E-W were especially numerous (Photo 9). Many of the lateral roots entered the trench from the east and belonged to trees outside the excavated area. Five remnant decayed stumps from 1979 were also found.

Well preserved acacia seeds (Photo 28) were commonly found throughout the 1979 reburial fill, about 1 per square meter every 5-10 cm spit, including immediately above the tuff surface and, in one case, inside a print (G2/3-30). Rootlets, presumably from grasses and, in the disturbed Trench 2, weed roots, were found throughout the fill,

especially in the upper 20-30 cm, but also on the tuff surface itself and within footprints as a fine matting.

FAUNA

A wide range of fauna was found in the 1979 reburial mound during excavation. The upper levels contained skinks, centipedes, small black beetles, and many ants. Mice and a nest with burrows were revealed in the disturbed area of Trench. Termites were very active in the dead stumps from the 1994 treatment of acacias with herbicides.

MAPPING

Surveying and mapping was undertaken throughout the season, principally by Chet Cain, assisted by other members of the team:

Reburial mounds: The N-S profile of the 1979 mound was mapped before excavation, and the tuff surface was mapped in after excavation (Fig. 9). During the 1995 reburial, fill materials were mapped to make final profiles of the reburial mound (Fig. 11).

Trench boundaries: After definition, the walls and key marker points of the 1979 trench were mapped into the 1995 trench boundaries. The 1979 trench walls generally conformed to the map of the trench made available to us by Mary Leakey (also published in Leakey and Harris 1987, Fig. 12.9), except at the southernmost end, but it differed from other published maps of the 1979 excavations (Leakey and Harris 1987, p. 493, Fig. 13.2; Day 1986, p. 185) (Figs. 12, 13 in this report). In particular, the east wall of the 1979 trench is 50 cm further to the east than shown on published plans, and the position of the footprints within the trench is 50 cm further west. This is probably because footprints were mapped in from measurements taken from the eastern boundary of the trench.

Trench Profiles: The E-W profile of the north wall and N-S profile of the east wall of the 1979/1995 trenches were also mapped, showing the 1995 ground surface, 1979 reburial material, 1979 ground surface, Augite Biotite tuff surface, and the footprint tuff surface (Figs. 8, 10).

Tuff Elevations: Elevations of the Footprint Tuff were taken within the 1979 excavated trench.

Trench features: Low resolution mapping of the location of faults, the Augite Biotite tuff, the weathered tuff of the trackway surface, and of hipparion and carnivore footprint trails in the trench was also undertaken.

Tree Stumps and Roots: All major tree stumps identified and inventoried in 1993 and 1994 on the reburial mound were identified in the 1995 trench, and their location mapped into the trench plan. This was subsequently used by conservators during treatment and documentation of roots. A field map was also made of the roots left in the trench after the removal of major roots (Fig. 6).

Elevations outside the trench: Levels were taken to establish the degree of dip of the tuff surface outside the trench. This was useful both for geological and archaeological documentation. Elevations were also taken of the surface area surrounding the site and main erosion gully, in order to facilitate construction of a new berm to redirect drainage away from the trackway (see Part VI).

Site Plan: Additional features were surveyed for the site plan (Fig. 1), including the 1995 excavated trench, tuff outcrops near the excavated trench, test areas, and locations of the berms.

CONCLUSIONS

The southern 10 m of the hominid trackway, Site G, preserved 29 hominid prints, and was always the most deeply buried, and best preserved section of the footprint trail. The 1995 re-excavation of this portion of the trackway was successful. It was accomplished over a four-week period without undue problems. However it should be emphasized that the re-excavation of much of the area was not a simple matter of brushing sand off the prints.

Lack of published survey information on the location of the footprint tuff within the mound, and of the dip of the tuff within the 1979 trench hampered re-excavation. Other concerns during excavation were the high degree of consolidation of the 1979 fill, the amount of moisture in the southern section of the trench, and the extensive growth of lateral acacia roots in the trench. Parts of the 1979 reburial fill, especially at the southern end of the trench, were extremely consolidated possibly as a result of the migration of clay particles and soluble salts. This necessitated use of considerable force in a carefully controlled manner in excavating upper layers of fill, and the development

1995 GRID AND DATUM POINTS

100/100 Point

It was intended that Trench 2 of the 1995 season would correspond to the 1993 assessment trench. In practice Trench 2 was re-aligned for a better fit with the N-S orientation of the 1979 reburial mound. As a result there is an approximately 6 degree difference between the N-S orientation of these trenches, and the 100/100 corner of the 1993 trench now lies southwest of the 1995 100/100 point, at E99.68 /N99.52 (Fig. 2). All coordinates are taken from the 1995 100/100 point.

Direction of increase of grid

The 1995 season started following the 1993 grid, increasing to the south and to the east. However, on Aug. 16, 1995 it was agreed to change this system to increase the grid in a northerly rather than southerly direction to conform to formal survey conventions and maintain compatibility with the photogrammetric survey and computer-based mapping programs. The direction of increase to the east remained the same. All raw data prior to August 16 remains in the original form, with the conversion system for increasing to the north recorded in notebooks. All maps were drawn following the co-ordinate system increasing to the north. This will be used in all following seasons of work at Site G.

List of Survey Datum Points

Major and minor survey datum points with their coordinates are listed below (see Figs. 1 and 4).

Major survey datum points

- E1** A point placed by the University of Cape Town (UCT) Photogrammetric team in 1995, and one of three major survey control points for UCT survey. Located within the 1995 trench, but outside the 1979 trench. Marked with a center punched brass stud embedded in concrete. "E1" inscribed in concrete. It is covered by the 1995 reburial. Location: E104.07/N93.49.
- E2** Originally a 1979 point marked with a wood peg in concrete. Second of three major survey control points for UCT survey. Located outside of the 1995 trench. The 1979 wood peg was replaced with a center-punched brass stud embedded in concrete. "E2" inscribed in concrete. It is visible outside the 1995 reburial mound. Location: E105.98/N103.25.

W1 A UCT survey point just south of coordinate N97/E100. Third of three external survey control points for UCT survey, and a point used by UCT to tie their photosurvey into the excavation grid. Point marked by a center-punched brass stud embedded in concrete. "W1" inscribed in concrete. It is covered by the 1995 reburial. Location: E100.00/N96.96.

W2 This was an existing 1978/9 point outside the excavation area. Marked in 1995 by a concrete marker with brass stud. W2 inscribed in concrete. It is visible outside the reburial mound. Location: E97.95/N102.90.

S This is a 1979 datum point, re-used in 1995 as the site datum, archaeology elevation zero. Also used by MMG surveyors in 1994 to plot the site plan. It is located SW of the 1995 trench. The original point was a concrete marker which was covered with a new layer of concrete in 1995 and inscribed with an "S". The elevation as established in 1995 is 51.72 (based on the MMG 1994 site survey). Location: E98.70/N86.95.

N Point placed by MMG surveyors. Marked in 1995 by a concrete marker and inscribed "N". It is located to the NE of the reburial mound. Location: E111.28/ N125.78. Site map in Fig 1 shows location of this point.

1979 grid points

Leakey Nail 1: This is a 1979 marker nail set in concrete. It is covered by the 1995 reburial. Location: E101.34/N96.02.

Leakey Nail 2: A 1979 marker nail at approximately the SE corner of the main body of the 1979 trench. It is covered by the reburial. Location: E104.35/N95.79.

of a technique of flicking out of adhering pebbles in lower layers, combined in places with the use of water and brushes. The tuff surface was very damp at the southwestern end of the trench, and in these areas it could be easily gouged or deformed if excavated when wet. When dry, these areas were also more fragile than the rest of the trench, and had been subject to embedding by coarse fill particles. Finally, lateral roots in the trench caused a considerable obstacle to excavators, and had to be carefully handled, since before they were fully exposed, it was not known at which point in the tuff, or at what depth they were finally located.

Survey showed that the published plans of the 1979 excavations should be modified as the trench is 50 cm wider towards the east than shown, and the footprints 50 cm further west. Ungerminated acacia seeds were found throughout the reburial fill, including on the tuff contact surface, and even in a hominid print. It seems likely that these were inadvertently introduced with the 1979 Garusi river sand used in the reburial. Re-excavation revealed abundant living fauna in the trench, mostly insects, which did not appear to be doing any damage to the tuff surface.

In general re-excavation showed that in the absence of roots, the 1979 reburial preserved the tuff surface well. It was very fortunate, and surprising, given the 38 trees in the trench, that most areas of root penetration did not coincide with prints. It seems that this was because roots penetrated areas where weaknesses from extensive weathering already existed in the footprint tuff surface, primarily in the northern part of the trench.



PART III. DISTURBANCE TO THE TRACKWAY AND TEST SITE 3

by Martha Demas

INTRODUCTION

In May 1995 the trackway burial mound and Test Site 3 were disturbed and vandalized. The reason for the disturbance appears to have been the same as that which motivated a similar disturbance in 1994, namely, theft of materials used in the reburial. The disturbances were investigated by the Antiquities Unit and left as they were found for further investigation by the project team.

THE TRACKWAY DISTURBANCE

An area of the southern burial mound, approximately 3.60 m (E-W) x 2.70 m (N-S), was disturbed (Fig. 9), which corresponded to the location and limits of the 1993 trench (which was itself disturbed in 1994). Within this area, the lava boulder capping stones had been tossed to the edges of the mound and soil moved to the sides where it was mounded, forming a crater-like pit roughly rectangular in shape (Photo 3). Soil had been removed to a depth of 20-30 cm. In the mounded soil around the disturbed area, but particularly noticeable on the east and west, there was extensive weed growth of a type not otherwise seen on the burial mound. The disturbed soil also proved attractive to field mice, whose numerous burrows were noted in Trench 2 during the excavation of this area.

Geotextile and Biobarrier[®] fabric had been placed in the trench during its reinstatement after the disturbance in 1994. A large piece of Biobarrier material that had been installed in the upper part of the mound in 1994 was removed in the 1995 disturbance. A small piece of geotextile (85 x 75 cm) had been placed as a horizon marker in an exploratory trench excavated to investigate the disturbance in 1994 (see 1994 Report). This was still *in situ*, indicating that the disturbance had not gone this far. The layer of black sand used in the 1993 reburial immediately above the footprint tuff surface also showed no signs of disturbance.

The only impact of this disturbance to the trackway itself was not noted until the trackway surface and the individual footprints had been fully excavated. At that time careful examination of the trackway surface revealed four similar puncture marks in the tuff. These were quite small and discreet, with a diameter of approximately 7.5 mm, and a distinctive protruding conical shape surrounding the puncture (Photo 13). It is

considered that these marks were almost certainly made by the steel spiked end of a spear shaft; experimentation in compacted soil with a local spear produced very similarly shaped puncture marks. It would appear that the spear penetrated the tuff when it was damp so that when it was removed it pulled the damp tuff up, resulting in an uplifted deformation of the tuff. Cracks in the tuff around the rim of the puncture hole may have been caused as the tuff dried and shrank.

Four such puncture marks were recorded during the condition survey (Fig. 6):

- 2 puncture marks in print G2/3-18 (Photo 13)
- 1 puncture mark in print G2/3-21
- 1 puncture mark some 0.70 m east of print G2/3-18

All four of the puncture marks are within the disturbed area, which corresponds, as noted above, to the 1993 assessment trench and 1994 disturbance. We thus conclude that the reason for the disturbance was to remove the geotextile material, which was encountered in the upper part of the mound, and that when further investigation by spear probing yielded no evidence of additional materials (the small piece of geotextile was missed), the perpetrators ceased their activity.

At the northern end of the trackway, adjacent to the NW gully, Enkamat[®] had been placed below a boulder capping to retain soil in this area in order to reduce erosion from water runoff. This area showed only marginal disturbance, but the Enkamat had been removed.

TEST SITE 3

The Test Site 3 mound had been dug into at three locations, roughly corresponding to the three test trenches established in 1994. The capping stones were removed and scattered from these areas only. The largest and deepest (40-50 cm) hole was directly above the trench used for testing Biobarrier in 1994. The disturbed trench was examined and found to contain none of the materials buried there in 1994.

A smaller hole had been dug near the center of the test site mound, also 40-50 cm deep, resulting in the removal of Biobarrier from the west side of the central test trench. The Biobarrier and test blocks (nos 2/1 - 2/8) on the east side of the trench were, however, still *in situ*. A third hole to south, only 20-30 cm deep, encountered the Biobarrier placed in the south trench, and this had also been removed.

As a result of these disturbances, little useful information could be extracted from the test site. Yellow staining from Biobarrier on test blocks, which was being tested in the undisturbed part of the trench, was able to be monitored. After removal of the Biobarrier from the stones, staining was visible for at least 48 hours and then gradually faded on exposure to the sun.

CONCLUSION

The disturbances at the site since 1993 have shown a consistent pattern of removal of buried materials with no indications of intentional harm to the trackway. Additional security mechanisms and other measures were put into place at the end of the 1995 season to address this continuing problem. These are discussed in Part XIV.



PART IV. CONSERVATION OF THE SOUTHERN TRACKWAY

by Jerry Podany, Angelyn Bass, and Eduardo Sanchez

INTRODUCTION

The conservation team's work began during the third week of the field campaign, after the archaeology team had excavated the 1979 fill to a level just above the Footprint Tuff and had begun exposing the tuff surface in Trench 2. The team assisted in the final re-excavation and fine cleaning of the trackway surface. Following complete excavation of the southern portion of the trackway with 29 hominid prints and numerous faunal prints the conservators conducted a full condition survey of the exposed tuff; stabilized areas of the trackway disrupted by root growth; removed and reduced acacia roots and stumps; and removed a Bedacryl[®] layer from selected hominid and hipparion impressions with acetone. In addition, Jerry Podany prepared consolidation test blocks for inclusion in the monitoring test trench (Test Site 3) and did consolidation tests on the floor of the test trench (see Part XIV).

The principal conservation work took place from July 17-August 11 under the direction of Jerry Podany, assisted by Eduardo Sanchez (JPGM), Angelyn Bass and Francesca Piqué (GCI), Jesuit Temba of the National Museum of Tanzania and Digna Tillya (AU).

RE-EXCAVATION OF THE FOOTPRINT TUFF SURFACE AND THE FOOTPRINTS

The excavation and fine cleaning of the trackway was carried out in two stages: first, the final layer of overburden was removed from the trackway surface, leaving the hominid and hipparion prints unexcavated. The conservators and archaeologists worked side by side to assure that the overburden was removed without damage to the tuff. After most of the trackway surface had been cleared, the individual prints were then excavated and fine cleaned. A log was kept which recorded the condition and characteristics of each footprint excavated. It noted the differences in the degree of compaction and hardness of the infill material, the amount of fine rootlets present, the degree of dampness, the characteristics of the infill, and differences in surface appearance compared to the 1979 cast.

Re-excavation of the first six of 29 hominid impressions (G1-34, 33, 27 and G2/3-20, 24, 25) was undertaken by Fiona Marshall and Jerry Podany using shaped wooden medical tongue depressors, soft wooden applicator sticks, and soft to medium-

hard bristle brushes (Photo 14). A field casts replicated from the 1979 cast, representing 21 footprints, was used to guide the re-excavation and were invaluable in defining the 1979 excavated surface, which was the boundary of the 1995 re-excavation effort.

The fill in the footprints was moderately compact at the upper layers, which in most cases was easily removed. In the deeper heel portions of the prints, where moisture likely collected, the fill was more consolidated, possibly because of re-deposited mineral binding agents such as salts and clay particles. The fill consisted of a wide range of particle sizes, some individual pebbles reaching a diameter of 1 cm (larger size pebbles were found in the fill outside the footprints) (Photo 15). Often, larger pebbles were grouped at the upper levels of the fill, with black sand and other fines concentrated near the surface of the impression. In some instances, a clear delineating layer of consistent sharp black sand was embedded in the Bedacryl coated surface of the footprints. But, this was not consistent from print to print, or even within the same print.

Following excavation and assessment of the first six prints, members of the conservation team completed re-excavation and fine hand cleaning of the remaining 23 hominid prints and 27 hipparion prints. Most of the prints were excavated with little complication, apart from G1-38, 39, G2/3-30, 31 and the surrounding tuff in the area of the small southern fault. Upon excavation, the surface of these prints was found to be distinctly damp and soft, and it was necessary to slow down excavation to allow time for the tuff to dry and harden. The damp tuff allowed fine sand and pebbles from the burial fill to embed in the surface. From sand embedding tests conducted at the GCI it was found that wetness of the tuff was a critical variable in the degree to which particles could embed in the surface (see Part XII). When the tuff dried the surface was rough from the embedded material, powdery in spots, and marked with numerous small cracks. Deeply embedded particles that could not be removed without pitting the surface were left *in situ*.

CONDITION SURVEYS AND RECORDING OF CONSERVATION TREATMENTS

Condition surveys

Prior to conservation treatment a full graphic condition survey of the exposed trackway surface was undertaken. The condition survey recorded loss, fractures, structural weakness and intrusive root growth, as well as adherent overburden or residues from silicone molding material and of previous treatments. Each condition was

assigned a graphic symbol, and the symbol was used to annotate clear acetate sheets that overlaid 8x10 color Polaroid photographs of the trackway (Appendix A).

Large format Polaroid photographs were taken of the trackway at two different scales. One set of 40 images called "flyovers" captured the full area of the exposed trackway in a series of 10 strips. Stainless steel wire frames, scored and printed at 5 mm intervals, were used in the flyover images to visually delineate the individual hominid prints. The next set of Polaroid photographs was taken of each framed impression at a closer range to achieve an approximate 1:1 ratio image. Graphic documentation of all features lying outside of the frame footprint impressions was carried out on the flyover images, while detailed documentation of each impression lying within the frames was carried out on the individual footprint photographs (Appendix A). The Polaroids functioned as a visual guide for the conservators' graphic annotation of features and conditions, including those not easily described in written form or captured in a photograph. Since the intention was to use the Polaroids as a guide, absolute consistency of color was not pursued and lens distortion of the image was not considered. (See further discussion of Polaroid photography in Part VII.)

In addition to the graphic documentation, written notes were taken to describe unusual conditions and to record comparisons of the footprints *in situ* with the field casts.

Recording conservation treatments

The same system of acetate overlays was used to record applied conservation treatments. Treatment locations were marked on the acetates with a graphic colored symbol, and a description of application procedures was hand written. Documented treatments included surface consolidation, fragment re-adhesion, void filling, and Bedacryl removal.

Following re-excavation and conservation of the remaining northern portion of the trackway in 1996, the graphic condition surveys and treatment records will be transferred into digital format to be used for future reference and study.

BEDACRYL COATING AND REMOVAL FROM G1-26 AND G2/3-25

After re-excavation and exposure of the tuff surface a dark stain was observed around and in each of the hominid prints and many of the animal prints (Photo 18). The

discoloration was later identified by IR spectroscopy as a layer of Bedacryl, a synthetic resin that was known to have been used to consolidate and harden the footprints prior to molding in 1979.

From comparison between the re-excavated hominid footprints and the cast impressions, it was clear that the Bedacryl caused a slight obscuring or loss of fine detail on the tuff surface. While there may be contributing factors such as the softening of the tuff by water with subsequent deformation by weight of the overburden, it was also clear that the resin caused a change in surface appearance. In some of the prints, the Bedacryl gave the surface a distinct "plastic" appearance. In other areas, where it was thinly applied, it produced a slightly shiny translucent character to the surface that appeared similar to a thin calcite layer. This was observable on print G2/3-25 prior to its cleaning. The dark stain caused by the Bedacryl was the result of the imbedding of fines from the overburden and change in the reflectivity of the surface.

Only in G2/3-18 (Photo 13) and G1-25 was Bedacryl missing from localized areas at the bottom of the impressions. Where the Bedacryl was absent, the tuff surface was light in color and had fewer embedded fine particles. The cause of the missing Bedacryl was undetermined.

The condition of prints with Bedacryl was variable: in some instances the resin was thin, evenly layered, and well adhered; in other instances the layer was thick, uneven, and slightly uplifted. Generally, the Bedacryl layer was thicker toward the bottom plane of the impression and in the deeper recesses. The layer usually thinned out at the upper flat surface of the tuff outside of the impression. It is inferred that the inconsistent thickness of the resin layer resulted from puddling of wet Bedacryl during application. It can also be assumed that conditions of application varied. Given the hot, windy conditions at the site, rapid evaporation of the solvent in the Bedacryl mixture would have sometimes occurred, resulting in uneven thickness of the resin layer.

In a few of the hominid footprints a fine root mat was present between the Bedacryl layer and the underlying tuff (Photo 17). Also in some of the footprints the layer was fractured or missing where blisters or bubbles were once located. The lacunae in these areas revealed a relatively white, soft under-layer of tuff directly or just below a root mat. There were also instances where the resin layer in and around the surface of

the footprint was peeling in thin, slightly flexible sheets where it had detached from the underlying tuff or calcite surface, such as in footprint G2/3-20.

The Bedacryl layer itself was in relatively good condition, and was still flexible and readily soluble in acetone. Infrared spectral analysis conducted on a Laetoli tuff sample not only confirmed the resin as Bedacryl, but it also showed there was no significant difference between the Laetoli sample and the GCI reference Bedacryl 122X sample, demonstrating that the Bedacryl found on the trackway has not degraded (Appendix B). Further analysis will be conducted on the Bedacryl to determine if any partial cross-linking has occurred, which would limit its ability to be completely removed in the future.

Field testing to remove the Bedacryl

To assist the palaeoanthropologists in their re-study of the impressions the decision was made to remove the Bedacryl from two hominid footprints. Prior to doing this the solubility of the resin in acetone was determined, and several small test patches were cleaned.

J. Podany tested the solubility of the Bedacryl by placing a minute sample of coated tuff removed from an area near footprint G2/3-20 in acetone. After five minutes the resinous tuff became gummy, and soon after completely dissolved, leaving behind loose granules of tuff and overburden. This proved the Bedacryl to be readily soluble.

Thereafter, cleaning methods were tested in three locations on the trackway:

1. Test A was conducted in Footprint G1-26. The test area, approximately 10 x 4 cm, ran from inside the footprint to the uncoated tuff outside the print (Photo 16). This area was in good condition, having a thin layer of Bedacryl overlying stable tuff with a calcite skin. Some of the resin was first removed with an acetone-wetted cotton swab. This successfully removed the Bedacryl from the flat surfaces of the tuff, but left small islands of resin mixed with sand and fines in the deeper depressions and textured areas. Acetone was then pipetted on the area in small amounts and a soft brush was used to loosen adhered particles. The solubilized Bedacryl and particles were immediately swabbed away before evaporation. Using this method the Bedacryl was completely removed from the test area, resulting in a clear distinction between the cleaned area and the surrounding tuff with Bedacryl (Photo 16).

2. Test Area B was in hipparion print B8. The print had a heavily fractured layer of Bedacryl at the bottom of the impression, and a thin layer of underlying tuff had delaminated and adhered to the resin layer. First the test area was swabbed with acetone to remove the surface layer of Bedacryl. Then a poultice of cotton moistened in acetone was applied to the area to loosen and dissolve the resin, and to absorb the Bedacryl and excess acetone. Dissolution of the resin caused the thin layer of delaminated tuff underneath to break up, and the soluble material could not be removed entirely without taking away some of the underlying tuff.

3. Test Area C was in hipparion print C2, a small print with a stable, unfractured surface. A poultice saturated in acetone was gently packed into the print and immediately covered with plastic film to inhibit solvent evaporation. The poultice was left in place for approximately fifteen minutes, and then removed. As with the method used in Test Area A, the poultice removed the Bedacryl from the flat surfaces, but not from the deeper recesses in the print. Where resin remained, acetone was brushed onto the area to assist in dissolution. The soluble material was then absorbed. By this method the Bedacryl layer was completely removed without harm to the print.

The results of the pilot cleaning showed that generally, where the Bedacryl was thin and overlies robust tuff with a stable calcite skin, it could be safely removed with acetone applied with a brush or in a poultice. However, where the resin was fractured, and the underlying tuff fragile, removal of the Bedacryl could result in loss of tuff.

Bedacryl removal from G1-26 and G2/3-25

Following test cleaning, the decision was made to remove the Bedacryl from G1-26 and G2/3-25. Potential risks, though determined to be minimal, were weighed in relation to the benefits of cleaning, understanding that the robust condition presented by these two prints was not necessarily characteristic of the majority of the impressions.

G1-26

G1-26 was a print in good condition, without fractures in the tuff surface, and with a stable calcite skin. The footprint was first lightly cleaned by brushing. Then, acetone was pipetted into the print and a soft sable hair brush was used to agitate and distribute the solvent. It was found that the use of generous amounts of acetone was effective in

removing the Bedacryl layer since it allowed dissolution of the resin with less brushing. At intervals, as the resin dissolved, it was absorbed with paper towels. The process was repeated until most of the surface was clean. Traces of Bedacryl remained in deep recesses of the impression and the surrounding tuff layer, but absolute removal of the resin in these areas was judged impractical and unnecessary. No discernible loss of tuff occurred as a result of the cleaning.

G2/3-25

G2/3-25 was a print in good condition with no apparent cracking of the Bedacryl layer or delamination of the underlying tuff. Also, the Bedacryl on the tuff surrounding the footprint was thin, well adhered, and well preserved. In the same manner used to treat *G1-26*, the heel portion of the print was cleaned first to allow the team to compare the treated and untreated halves of the print (Photo 17). Removal of the Bedacryl clearly exposed the "invalid heel impression" described by Leakey and Harris (1987, p. 494).

The remaining anterior portion of the footprint was cleaned with poulticing and brushing techniques. Brushing with acetone was only necessary on the termite burrowed rims of the print where the resin was concentrated. Bedacryl was safely removed from the print without damage to the underlying tuff (Photo 17).

The result of removing the Bedacryl from the two prints was a slight improvement in the definition of fine details on the tuff surface, and reduced discoloration.

It was concluded that the removal of Bedacryl from more deteriorated tuff found in many of the impressions would pose a considerable risk and was not absolutely necessary for re-study or documentation. Most importantly, the Bedacryl coating is not harming the prints, but removal could result in some loss. For this reason, removal of the Bedacryl did not extend beyond the two hominid prints.

CONSOLIDATION AND RE-ATTACHMENT OF THE FOOTPRINT TUFF

In some areas, especially in the northern four meters of the re-excavated area, the tuff was disrupted or detached and required stabilization. In most cases disruption and detachment had been caused by acacia roots that had penetrated the tuff and grown laterally, uplifting and dislodging the overlying tuff (Photos 19 and 21). To assure there

was no additional displacement of loose tuff fragments, fragile areas in the immediate area of large roots were stabilized with a consolidant and/or reinforced in place.

Surface stabilization of fragile tuff was achieved by consolidating the weak area with a 4% aqueous solution of Acrysol[®] WS-24 acrylic dispersion, followed by an application of the same dispersion at full-bottle strength. Acrysol WS-24, a water-borne consolidant at 50% by weight methyl and ethyl methacrylate as a copolymer, is widely accepted for use in conservation as a safe and stable consolidant. It was chosen for use based on its successful performance in field tests at Laetoli in 1993 and 1994 (see **1993 and 1994 Reports**) and for its properties of a neutral pH at 6.8, a high glass transition temperature (39°C), and small particle size (0.03µm) which allows for greater wettability and penetration into the tuff. The consolidant was applied to the area to be treated by a cannula-tipped syringe or pipette (Photo 19). This allowed for precise injection and application into the needed area. By consolidating with Acrysol WS-24 the strength of fragile areas increased sufficiently to allow root removal by a micro-rotary saw or root reduction by means of a mini-router.

In areas that required more extensive stabilization, such as where root extraction had left a void that could slump or collapse under the weight of overburden tuff, or where the tuff was disrupted and gaps between or underneath fragments required stabilization (this only occurred in the area north of the weathered tuff) a paste of full strength Acrysol WS-24 with Aerosil[®] 200 hydrophilic fumed silica was used. The adhesive paste was extruded into voids or recesses through a syringe. After a short time, the paste hardened and dried to a translucent white solid that is clearly discernible from the surrounding tuff.

In a few cases, re-adhesion of detached tuff fragments was necessary. For reattachment of larger fragments, commercially prepared H.M.G. (Paraloid[®] B-72 acrylic resin in organic solvent) was used as the adhesive. The detached fragment was removed, the bonding surfaces were brushed and pre-wet with acetone, and the fragment was reattached with the B-72 solution. For smaller fragments, both the full strength Acrysol WS-24 or the Acrysol paste were used, depending on the size of the contact area (Photo 22). Both solutions were injected through a syringe. Approximately 21 locations on the Footprint Tuff required re-adhesion of detached fragments. Treatments are recorded on the condition acetates.

STUMP AND ROOT REMOVAL

Thirty-three acacia trees had grown in the 10 x 4.5m excavation area since 1979, 16 of which had taproots penetrating the footprint tuff surface (Photo 5 and Fig. 6). Five stumps and roots from 1979 were also uncovered: two penetrated the tuff north of the weathered area, and one pierced the center of G1-30. All of the 1979 roots had rotted and disintegrated. Over 87 percent of the penetrating taproots were located in the northern four meters of the exposed trackway. In the southern portion, acacia roots tended to grow laterally above the footprint tuff horizon. Damage in this area from penetrating roots was far less severe. (See Part V for further discussion.)

Four prints, G1-28, 32, and G2/3-21 (Photo 23), 22, located in the area of weathered tuff, had been damaged by roots since 1979. Roots were either growing directly into or along the edges of the impressions, further disrupting what were considered in 1979 to be poorly preserved prints. (Leakey and Harris, 1987, p. 491-494). Prints G1-28, 29, and 30 were noted in 1979 as damaged by root growth.

Extraction or reduction of the acacia stumps and roots involved an initial determination as to whether the entire root could be completely removed or reduced in size with a mini-router. In some instances, lateral penetration of the root along the surface of the tuff and through a raised feature allowed complete removal of the root section (Photo 24). In most cases, however, where the root penetrated vertically into the tuff, only removal of the visible section of the root could be achieved. The remaining root end was then reduced to a level slightly below the tuff surface.

Four methods were used to cut root sections. In the case of large stumps a thin fine-tooth mini-handsaw was used to cut away the root or stump as close to the tuff surface as possible (Photo 25). In the case of small or very fine roots, a surgical scalpel was used to make the cut. For medium diameter roots a battery powered rotary mini-drill fit with a circular micro-blade was used. The microsaw had the advantage of high speed, but low torque. As a result the operation could be carried out with minimum vibration and maximum control. In some instances, because of the awkward position of the root, it was severed using the rotary mini-drill fitted with a micro-router bit (Photo 26). Layers no more than 0.25 mm were milled away until the entire root was severed. This technique also assured low vibration and complete control of the cutting.

Prior to cutting the stumps and root sections, the surrounding tuff was assessed for its ability to resist minor vibrations and movements occurring during the cutting operation. Where the tuff was unstable or disrupted, it was consolidated with Acrysol WS-24 to strengthen it (Photo 19). After cutting the stump or severing the root, the remaining wood was reduced below the exposed tuff surface by routing the cross-section with the mini-drill fit with a micro-router bit. To minimize vibration the wood was slowly milled away in 0.25-0.5 mm layers. Where roots were completely removed leaving a void or channel these were filled with the Acrysol WS-24 and Aerosil 200 paste to prevent collapse or distortion of the tuff following reburial.

In some cases lateral roots that were removed left an impression on the tuff surface. These impressions were generally shallow, made by small roots, and did not cause serious physical disruption to the tuff. Root impressions were primarily found in the area of the weathered tuff and on the surface of the Augite Biotite tuff at the southern end of the excavation area (Fig. 6).

As a final treatment for roots left *in situ*, a preservative was injected into the remnant roots to discourage insect activity and to prevent fungal rot. Holes were drilled into the center of each reduced root or stump and a solution of pentachlorophenol in acetone and isopropyl alcohol was applied. Discussion of the preservative treatment is found Part V.

CONCLUSIONS

As sections of this report and previous field reports have noted, the intrusive root growth within the overburden and tuff layers of the trackway presented a serious and direct threat to the long-term preservation of the hominid footprints. Re-excavation, carried out to determine the extent of this threat and the degree to which damage had already occurred, revealed that the footprint layer had been disrupted in several areas by intrusive root growth and these areas required stabilization.

Final re-excavation was undertaken jointly by the archaeological team and the conservators. Due caution was exercised to ensure that no alteration occurred to the tuff surface during re-excavation and that only what the Leakey team uncovered in 1979 would be exposed.

Guided by the overall principle of minimal intervention, the conservators cleaned the tuff surface of overburden to a point that allowed detailed documentation of its present condition and associated morphological features. In some instances small amounts of the overburden were left *in situ* since the finer granules had become firmly embedded in the tuff and there was concern that their removal might risk damage to the tuff surface. Isolated areas where fragments of the tuff surface had become dislodged or disrupted, predominantly due to intrusive root growth, were re-adhered and consolidated using a well known and reversible acrylic adhesive and an acrylic consolidant, respectively. This was done to fully stabilize these areas prior to reburial.

Root removal was achieved in a variety of ways, from scalpel cutting to the use of low-torque rotary mini-saws and routers. All of the roots existing at or above the foot print tuff layer were removed and those that had penetrated the layer were reduced to below tuff level. This was done in order to allow stabilization of the disrupted areas and to reduce the amount of biodegradable material present in the trackway.

A layer of Bedacryl resin was found coating each individual footprint impression and the tuff surface around the perimeter of each impression. It is unclear whether the Bedacryl coating contributed to the preservation of the footprints, but there is no evidence that it caused damage. However the thickness and uneven placement of the Bedacryl layer masked the detailed morphology of each impression and in order to allow examination for the scientific restudy of the footprints, this layer was removed from two of the best preserved impressions.

Thus, the changes to the condition of the trackway since 1979 were the result of intrusion of roots into the tuff surface, the embedding of granular fill material, and the application of the resin Bedacryl to the impressions. None of these impacts to the trackway have significantly damaged or altered the hominid trails--particularly those in the well preserved section of the trackway--which remain in very good and stable condition.



IR SPECTRA

Resin sample extracted with xylene from G1-35 (red)
Bedacryl 122X standard reference (green)

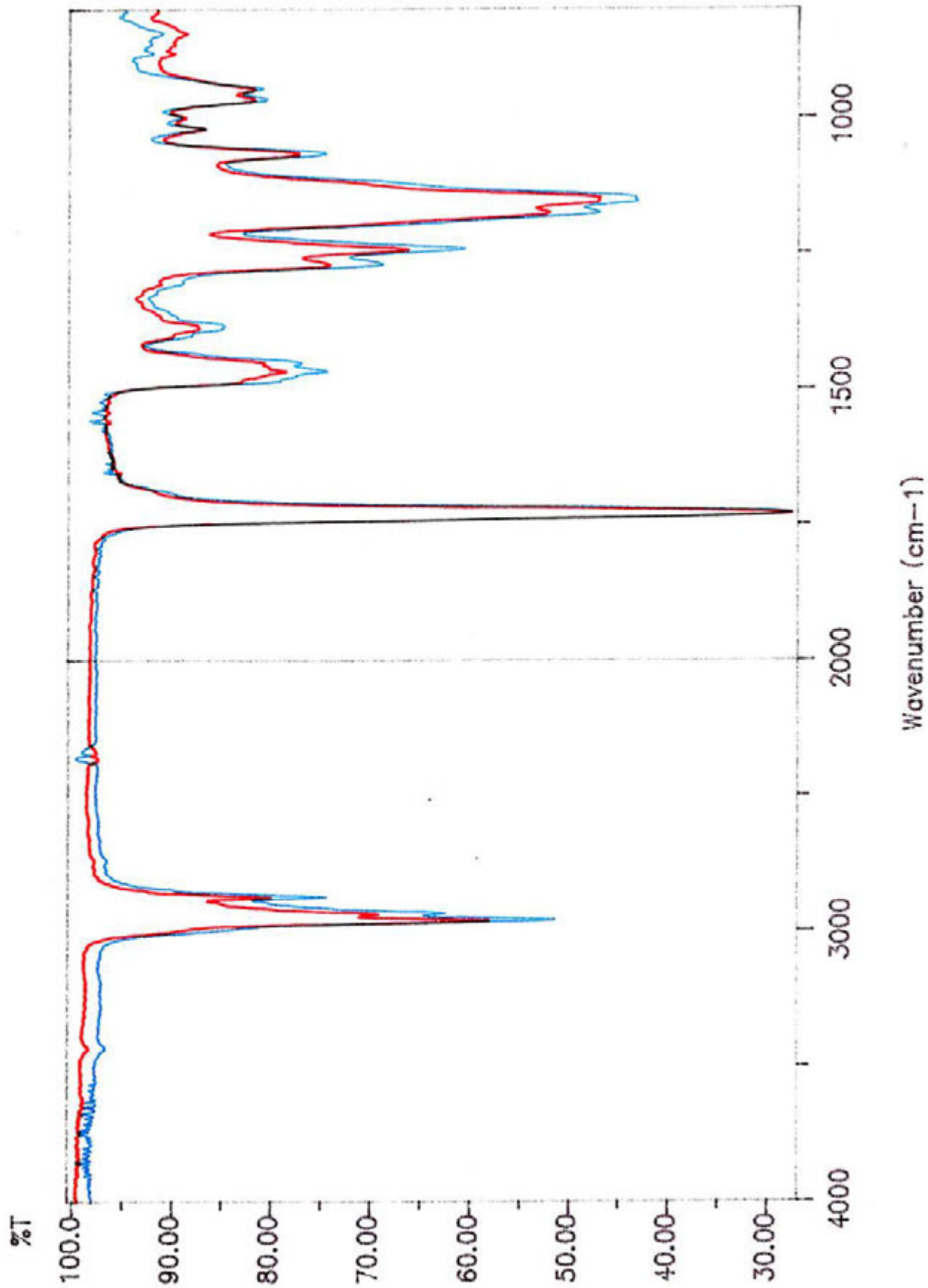

PART V. ACACIA TREES AND OTHER VEGETATION ON THE TRACKWAY

by Neville Agnew, Angelyn Bass, and Po-Ming Lin

ASSESSMENT OF DAMAGE TO THE TRACKWAY FROM ACACIA TREES

Excavation of the southern trackway revealed physical disruption of the hominid footprint tuff surface by acacia root growth. Thirty-three acacia trees had grown within the 10 x 4.5 m excavated area since 1979, 16 of which had taproots that penetrated the tuff surface. An additional five roots remaining from 1979 were also found. Three hominid prints, all located in the poorly preserved area of weathered tuff, had been damaged by roots prior to 1979: G1-28, 29, 30, and the surrounding tuff had been cracked and distorted by small acacia tree and grass roots (Leakey and Harris 1987, 491-494). Re-excavation in 1995 revealed that acacia roots had since damaged four footprints: G1-28 (for the second time), 32, and G2/3-21, 22, as well as numerous areas of the tuff surface without prints.

An inventory and location map (Fig. 6) was made to record existing dead acacia stumps and roots. The inventory registers the stump number (based on the 1993-94 survey), stump dimensions number of adventitious roots, evidence of insects or rot, and method of cutting and treatment.

According to the 1993 survey of plants growing on and near the trackway (see 1993 Report) the common species of acacia were: an unidentified acacia tentatively identified as *Acacia seyal*¹ (Photo 28) 69%; *Acacia drepanolobium* (whistling thorn), 22%, and *Acacia mellifera*, 7%. *A. drepanolobium* predominates beyond the trackway boundary. It was speculated in 1993 that seeds of the then unidentified acacia were introduced in the fill used to rebury the site in 1979. This was based on observation that the unidentified acacia species was dominant on the reburied trackway and in the spoil heap left over from the 1979 backfilling, and is found only sporadically beyond the reburial mound. Numerous acacia seeds recovered from the fill during re-excavation in 1995 confirmed this speculation (Photo 28). The recovered seeds appear to be identical to those of the purported *A. seyal* of the trackway, having an average length of 5-7 mm and a compressed shape. Following the field campaign collected seeds were planted in Arusha by Dr. Joel Bujulu, but have not germinated, probably because they are not viable.

¹ This acacia was observed in flower in February 1996 during the wet season, and its identification will be verified during the 1996 field season.

REVIEW OF PREVIOUS TREATMENT OF ACACIA TREES WITH HERBICIDE

In 1992, following partial exposure of a 3 x 3 m portion of the trackway that revealed the acacias' extensive root systems with taproots and adventitious roots penetrating the tuff, the decision was made to kill acacias growing on and adjacent to the trackway. Two broad-spectrum, bio-degradable herbicides, Roundup[®] (glyphosate) and Tordon[®] 101 (picloram plus 2,4-D) were tested at an off-site area (Test Site 3) in August 1993. Evaluation of the test site in May 1994 revealed that both herbicides were effective in killing acacias. At that time 75 trees were treated: 35 trees in the northern portion of the trackway with Tordon, and 40 trees in the southern portion with Roundup. Thereafter, in following campaigns, Roundup was used to treat an additional 90 trees on and in a zone 3-6 meters wide around the trackway.

Herbicide was applied by either infiltration or by brush; sometimes a combination. Larger trees were crosscut 10-15 cm above the ground surface; then, depending on the diameter of the tree stumps, a 3-12 mm diameter hole was drilled in the cut surface of the stump and the herbicide was applied to the hole. In instances of smaller trees, the bark below the cut was frilled with a knife and painted with herbicide; subsequently, both methods were found to be effective. These methods confined the herbicide within the root system.

1995 assessment of treated acacia stumps

All but one of the acacias uncovered on the trackway were dead. Stump #20 located on the eastern border of the 1995 excavation trench showed new growth. It was cut, drilled, and treated with Roundup. In general the dead tree stumps and roots on the trackway were desiccated. Shrinkage of individual roots had not occurred to the extent hoped for and this affected the ease with which they could be surgically removed.

Biodeterioration caused by termites, larvae of wood-boring beetles, and rotting fungi was plentiful in most of the dead stumps. Live termites collected from acacia stump #17 on the trackway were identified by Joel Bujulu as dry-wood termites *Procryptotermes* sp. (Family *Kalotermitidae*). Many of the stumps had galleries filled with frass of borer beetle larvae. Beetle larvae, as yet unidentified, were also found in treated stumps northeast of the trackway. Fungi were not identified, but were visible as whitish mycelium on the bark, especially below ground.

Five roots cut in 1979 were found: three penetrating the surface in the area of weathered tuff, and two located just outside the 1979 trench boundary (Fig. 6). All five roots had rotted. In cases where any fibrous root cortex remained, it was powdery to the touch and contained remnants of insect casings. In G1-30, all that remained of a root was a trace of the bark inside a void. In all instances where the 1979 stump or root had disintegrated the surrounding tuff was structurally stable and not in danger of collapse.

Insect activity in the treated stumps on the trackway suggests that the Roundup applied in 1993-94 had degraded. Furthermore, it was observed that insect life and vegetation were plentiful adjacent to the herbicide treated roots on the trackway and at Test Site 3, indicating that the herbicide was indeed retained within the treated root stocks and had not leached into the surrounding soil.

DISTRIBUTION AND GROWTH PATTERN OF THE TREES GROWING ON THE TRACKWAY

Acacia stumps and roots were concentrated in the northern 4 m and in the southern 3 m of the re-excavated trench. In the northern portion, where the tuff is naturally weathered, penetration of the footprint tuff surface from roots was widespread (Fig. 6). Fourteen of 16 penetrating taproots were located there. The diameter of the roots in the north was substantially larger than those in the south: the average root diameter at the point of tuff penetration was 2.8-3.0 cm, the largest diameter being 7.1 cm (stump #21) and the smallest being 1.9 cm (stump #20). Large diameter taproots tended to pierce the tuff vertically, destroying the tuff in direct contact, and causing only minor disruption to the surrounding tuff. Adventitious roots caused extensive damage to the tuff by growing laterally along the surface within existing cracks and fissures (Photo 19).

Acacia roots in the southern part of the trackway caused considerably less damage to the tuff than expected. In that area, where the Footprint Tuff is unweathered and well cemented with calcite and was protected by a thick mantle of overburden, and where, consequently, the best preserved footprints are located, the acacias developed adventitious roots that grew laterally above the footprint tuff surface (Photo 5). Only two acacia stumps, #13 (Photo 21) on the east border of the 1979 excavation trench, and #15 on the west, penetrated the tuff surface. Neither directly impacted the hominid tracks. The tendency for roots to grow laterally above the unweathered tuff surface could be due in part to the deeper fill found in this area. The footprint tuff surface dips an average of 7° in a southwesterly direction, and on re-excavation this section was

moist, indicating drainage on this horizon. Thus, the moisture requirements of the trees were met above the tuff surface and the unweathered tuff was not easily penetrated.

From examination of the stumps exposed on re-excavation, it seems that germination of the acacia seeds occurred at different levels in the fill. The point of germination, where stems separate from roots, can be found close to the tuff level (as in stump #27) and up to 30 cm above the tuff at ground level (as in stump #13) in the southern portion of the trackway.

TREATMENT OF STUMPS AND ROOTS ON THE TRACKWAY

Reduction or extraction of stumps and roots

Stumps and roots found on the trackway were extracted or reduced by hand with either a small flexible saw or a surgical scalpel, or mechanically with rotary mini-drill fitted with circular cutting blades or micro-router bits, as noted in Part IV. Decisions about cutting methods and extent of root removal were based on root diameter, and on how the root physically penetrated the tuff surface. In most cases, roots that penetrated vertically into the tuff were reduced to a level flush or just below the tuff surface. In a few cases, lateral penetration of the root allowed for complete removal of the root section. Description of the root cutting procedures is more fully covered in Part IV.

Preservative treatment of stumps and roots remaining on the trackway

Frequently, it was not possible to safely remove all acacia roots from the trackway. The question arose as to the eventual fate of woody material that remained *in situ*. There was ample evidence of termite activity in the stumps on the trackway that had been treated with Roundup in 1994, and in the few roots that penetrated the trackway and that had been reburied in 1979, fungal rot had badly decayed the wood. There was concern that voids resulting from decayed or infested wood could eventually slump or collapse under pressure of the reburial overburden. To slow root decay and discourage insect activity a preservative treatment was applied to all roots remaining *in situ*.

A number of chemical preservatives for wood, effective against termites and fungal rot, were considered. Factors such as toxicity and safety aspects in handling the preservative, persistence and effectiveness under conditions in the reburial mound, migration out of the treated wood, and environmental hazard were assessed. The choice

narrowed to several options: borates, arsenicals, naphthenates of copper and zinc, and polychlorinated hydrocarbons. The first is widely used and is effective but was ruled out because of its poor penetrability, unless pressure injection is used, and its water solubility. In fact, water as a carrier for wood preservatives was judged an undesirable method of application because water swells wood fibers, which quickly slows further penetration. Furthermore, the reburial environment at the site is quite moist, at least in part, and water soluble preservatives would probably leach from buried wood over time.

Arsenious oxide is highly effective against termites, but is, of course, extremely toxic, and can only practically be applied as an alkaline sodium arsenite aqueous solution. Although the tuff and soil of the site are both alkaline because of the pervasive presence of carbonate, a high pH solution is undesirable because of possible long term adverse affects should leaching into the tuff occur, and because of hydrolysis of wood cellulose and lignins by the alkaline solution. Naphthenates are insoluble in water and in acetone and isopropyl alcohol, the two solvents locally available. They were not, therefore, seriously considered further, although tested as described below.

Of the polychlorinated hydrocarbons, pentachlorophenol (PCP) was decided upon for its effectiveness and persistence. Two forms are available: the phenol itself, which is insoluble in water, but readily soluble in polar organic solvents such as acetone; and the water-soluble sodium salt. After consideration, the latter form was rejected because of the likelihood of poor penetrability and the possibility of leaching; while the former, dissolved in a mixture of acetone and isopropyl alcohol, penetrates well because of miscibility of these solvents with water, and after evaporation of the solvent it will not leach from the wood.

PCP has been the subject of numerous studies because of its potential environmental impact. It has been shown to undergo slow soil microbial degradation (for example, Pentachlorophenol—Chemistry, Pharmacology and Environmental Toxicology, ed. K. Ranga Rao, Plenum Press, 1978). In the present circumstances, and because of the very limited quantity used, with an application method that is precisely localized, and because it is not exposed to the atmosphere, its use was determined to be entirely appropriate and without environmental consequences.

PCP was imported under permission from the Tanzanian government (Ref. No. UTV/AR/K.20/11/89, June 30, 1995). Aldrich Chemical Co. supplied the PCP: Lot # MF 01907 MH, technical grade, 100g; and Lot # DN 07203 TY, pure, 100g.

The two batches of PCP (200g) were mixed and dissolved in a mixture of five liters acetone and isopropyl alcohol (1:1). The solution was applied twice to residual stumps and roots on and adjacent to the trackway, but within the area of the reburial mound, with time for absorption between applications. The solution was applied by dropping pipette to holes 2 x 15-20 mm deep drilled into the cut stumps and roots. Judicious application to the root and stump bark where exposed was also done. The total amount of PCP used on the trackway and in the reburial monitoring trench (Test Site 3) was approximately 190g. Amounts used on individual stumps are recorded in the inventory (see also report by J. Bujulu, pp 10-12).

Off-site testing

Limited testing of preservatives for wood was done external to the reburial sites in order to be able to visually assess their effectiveness on dead acacia wood over the next field season. Four acacia stumps, #75, #81, #146, and #80, treated with Roundup in 1994 to the north east of the site were treated with PCP, and its sodium salt, and with copper and zinc naphthenate, respectively.

Galleries of borer beetles were noted in several of the stumps during their preparation for treatment, and a number of live larvae were observed and photographed.

1. Stump #81, approximately 10 x12 cm in diameter, was cut 5 cm above ground level, and drilled with six 12 mm holes to a depth of 100 mm, and five 6 mm holes 50 mm deep. This stump was treated with sodium PCP (6g in 60 ml water, i.e., 10% w/v) by dropping pipette to the holes, surface of the stump, and between the bark and the wood. The external surface of the bark was not treated.
2. Stump #80, approximately 6 cm in diameter, was similarly cut and had two holes 12 x 100 mm and two 6 x 50 mm deep. Treated with 3g of zinc naphthenate in 30 ml acetone as a slurry applied as above.

3. Stump #75, approximately 10 x13 cm in diameter, was cut and drilled with the same number and size of holes as #1. Treated with 10g PCP in 100 ml acetone.
4. Stump #146, a double stump, approximately 3.5 cm and 5.5 cm in diameter, had one 12 x 100 mm central hole and three holes 6 x 60 mm deep. These two stumps have a common base and are one tree. They were treated with 1.3g copper naphthenate in 20 ml acetone as a slurry.

Upon completion of treatment the stumps were covered with polyethylene film held in place by a rubber band for a few days to limit evaporation of solvent and aid penetration (see also report by J. Bujulu, pp 4-5).

THE ROLE OF PLANTS IN ROCK DETERIORATION

In addition to acacia trees, abundant annual and perennial shrubs, weeds and grasses flourish at Site G. During the 1995 re-excavation, fine roots, often in mats, were found extensively throughout the reburial fill, and many were growing in contact with the footprint tuff surface.

The role of plants in the physical and biochemical weathering of rock types is well documented. On the macroscopic scale the wedging effect of growing plant roots along and into rock cracks has been studied (see for example, The Nature of Weathering-An Introduction, Eiju Yatsu, Sozosha, Tokyo 101, 1988, p.365); while on the microscopic scale metabolic processes in rootlets produce various organic substances, some of which cause dissolution of mineral components, thereby releasing soluble elements that are absorbed as nutrients.

While physical disruption is the more alarming manifestation of acacia root growth, more pervasive and insidious may be the role of fine roots in the conversion of the tuff into weathered clay-rich material--like that seen in the northern area of weathered tuff in the trench where weathering occurred, presumably as a consequence of only a very thin "skin" of protective soil and overburden that remained as a result of erosion of the site prior to discovery and excavation. SEM examination by Eric Doehne of unweathered calcite cemented footprint tuff (from a fallen block in the NW gully) showed root hairs penetrating the tuff and physically disrupting it.

While the relative importance of the role of plants on the one hand and chemical processes on the other on the rates of natural weathering and mineral transformation cannot be gauged at Laetoli, both are certainly important. The Laetoli tuff is rich in volcanic glass (produced by very rapid cooling). The rate of weathering in tephra in general is higher than that of volcanic rocks of the same chemical composition because of the much larger specific surface of the volcanic glass component available to react with water in the presence of oxygen (Yatsu, 1988, p.146). Thus, for now no information is available on mineralogical changes of the Laetoli tuff caused by roots other than the obvious damage of penetration and physical disruption.

IDENTIFICATION OF VEGETATION AT SITE G

This season, prior to re-excavation, samples of vegetation growing on the trackway were collected and identified by Dr. Joel Bujulu (see Appendix A). Appendix A also lists the plant species growing throughout Site G as identified by L.B. Mwasumbi in 1994. As with Mwasumbi's 1994 survey (full description in 1994 Report) the 1995 plant list may be incomplete since specimens were collected during the dry season when flowers or fruits were not present and annuals would have been dead.



APPENDIX A

VEGETATION RECORDED AT SITE G IN 1995 AND 1994

CLASSIFICATION	GROWING ON AND NEAR TRACKWAY, 1995 (Identified by J. Bujulu)	GROWING AT SITE G, 1994 (Identified by L.B Mwasumbi)
TREES		
<i>Acacia mellifera</i>	X	X
<i>A. drepanolobium</i>	X	X
<i>A. kirkii</i>		X
<i>A. seyal</i>		X
<i>A. sp</i>	X	
<i>A. tortilis</i>		X
<i>Boscia angustifolia</i>		X
<i>Commiphora africana</i>		X
<i>Rhus natalensis</i>		X
SHRUBS, HERBS & WEEDS		
<i>Abutilon angulatum</i>		X
<i>A. hirtum</i>	X	
<i>Asparagus africanus</i>	X	X
<i>Aspilia mossambicensis</i>	X	
<i>A. sp</i>		X
<i>Barleria sp.</i>		X
<i>Bidens pilosa</i>	X	
<i>Capparis fascicularis</i>		X
<i>C. sp.</i>		X
<i>Cissus quadrangularis</i>		X
<i>Conyza pyrhopappa</i>		X
<i>Crotalaria laburnifolia L</i>	X	
<i>Duosperma crenatum</i>		X
<i>Hirpicium beguinotii</i>		X
<i>Hypoestes forskalii</i>		X
<i>H. verticillaris</i>	X	

CLASSIFICATION	GROWING ON AND NEAR TRACKWAY, 1995 (Identified by J. Bujulu)	GROWING AT SITE G, 1994 (Identified by L.B Mwasumbi)
<i>Leonotis sp.</i>	X	
<i>Maytenus heterophylla</i>		X
<i>Plectranthus caninus</i>		X
<i>Solanum incanum</i>	X	
<i>S. sp.</i>		X
<i>Tagetes minuta</i>	X	X
<i>Vernonia sp.</i>		X
<i>Ximения americana</i>		
<i>Zanthoxylum chalybeum</i>		X
GRASSES		
<i>Aristida adscensionis</i>		X
<i>A. kenyensis</i>	X	
<i>Chloris gayana</i>	X	X
<i>C. sp.</i>		X
<i>Cynodon dactylon</i>	X	X
<i>Hyparrhenia cymbaria</i>	X	X
<i>Panicum maximum</i>	X	
<i>Polypogon plebeium</i>		X
<i>Seteria sphacelata</i>		X
<i>Sporobolus africanus</i>		X
<i>S. spicatus</i>		X

PART VI. DRAINAGE CONTROL AND SITE STABILIZATION

by Neville Agnew

INTRODUCTION

Site stabilization efforts in the form of drainage control systems and stabilization of the NW gully were the principal focus of activities at Laetoli in 1994 (see 1994 Report). During the 1995 season, these efforts were evaluated and additional work was undertaken based on the assessment of performance over the previous year.

CONTROL OF DRAINAGE

Two surface berms (Berms 1 and 2) were constructed on the site to the east of the trackway in 1994 (Fig. 1). The purpose, as stated in the 1994 report, was to divert surface run-off from the trackway during the wet season. Sheet flow of water from the south-east across the northern end of the trackway and into the NW gully was eroding the trackway, and the head of the gully advanced, threatening the hominid tracks at the extreme northern end of the trackway.

Evaluation of Berms 1 and 2

At the beginning of the 1995 season the berms were evaluated both to assess their effectiveness in diverting water and their ability to withstand erosional undercutting, since in order not to intervene irreversibly on the site the two berms of 1994 had been constructed on the ground surface. The berms were made from lava boulders and a weak soil cement mixture.

It was clear from some undercutting at the northern end of Berm 2 that the force of the run-off water during the preceding wet season had been considerable. The increased water flow to Drainage Channel 2 was evident from a small enlargement in size and depth of the channel, particularly at the northern end. From this it is inferred that both berms had functioned as intended and had reduced the total volume that previously debouched at the northwest gully.

Despite diversion of water away from the NW gully, examination of the flat area to the east of the northern portion of the trackway and in the gully itself, showed clear evidence of much water having continued to reach the gully from Drainage Channel 3. Ponding had occurred in the flat area; and in the NW gully itself, erosion below the upper, low retaining wall of cemented boulders across the gully was noted. The

catchment area in question is fed by Drainage Channel 3 and is conservatively estimated as 25 x 60m, or 0.15 hectare. Average per annum rainfall from figures provided by the NCAA for the nearby village of Esere is 540 mm (21.5 in.) over the period 1989-1994. Thus this catchment may yield some 750 kiloliters of runoff to the northwest gully per annum (neglecting seepage into the soil). And this amount is invariably concentrated in the rainy season from November to April.

Construction of Berm 3

It was thus deemed necessary to intervene further during the 1995 season by constructing an additional berm (Berm 3 on Fig. 1) to intercept the sheet flow of water from the south into the flat area between the existing berms and the trackway.

In considering the layout of the new berm it was clear that few options existed because of the topography of the site, and that the point of debouchment of the new berm would need to be the same as that of the two existing berms, via Drainage Channel 2 (Fig. 1). A further complication was the existence of the low-lying area mentioned above. Levels were taken and revealed the lowest point to be some 25 cm below the outlet point of the existing berms on Drainage Channel 2. Consequently, construction of the berm was required to be of sufficient height to avoid it being overwhelmed; and it was, of course, realized that ponding would result in the middle of the berm at the lowest point. This, however, was judged preferable to continued erosion of the northern end of the trackway by strong water flow. A decision will be made during the 1996 season on the problem of ponding (which was observed during the Consultative Committee's visit to the site in February 1996 after heavy rain).

Berm 3 was sited below the fault that approximately bisects the trackway, and runs northeast in a curve to Drainage Channel 2. It is approximately 24 m long and at its highest point, where it crosses Drainage Channel 1, it is 30 cm high (Photo 29). The construction method was the same as that used in 1994, though a slightly different cement mix was used in that no fine gravel was included. The wet cement was colored on the surface, as previously, with dark mineral sand gleaned from the Garusi gully to the north of the site.

As mentioned above, the functioning of the berm was observed in the early part of 1996, after heavy rain. It acted to dam water, stopping active flow towards the northwest gully. Thus, the berm is performing well. In 1996, either the depression will

be filled to grade the drainage towards the required outlet, and the berm height will have to be extended; or, alternatively, a channel will have to be cut along the line of the berm from the lowest point of the outlet. The latter option is less desirable because Footprint Tuff will need to be removed to form a channel, although Mary Leakey confirmed that there are no prints of consequence in that area. A further concern is the concentration of all the site drainage to one outlet, which can be expected to erode rapidly. At present the outlet to the Garusi gully is only a shallow one, though its depth increases rapidly to a narrow defile some 2 m deep as it enters the Garusi drainage system.

To minimize erosion of the exposed tuff at the outlet to the Garusi at the northern end of Berm 3, the edges of the tuff were banked and stabilized with stones set in a weak cement in an area (43 cm wide x 55 cm long) directly adjacent to the end of the berm. On either side of the cemented area, the edge of the tuff was reinforced with small lava stones and blocks of tuff.

Repair to Berm 2

The northern end of Berm 2 was somewhat undercut due to the flow of water during the wet season. Exposed earth was lined with cement to the base of the channel in order to prevent further undercutting, and the bottom of the drain was lined with lava boulders to break the force of water flow. Soil was placed in the channel around the boulders.

NW GULLY AND ADJACENT STABILIZATION

Stabilization of the slopes of the NW gully undertaken in 1994 was evaluated. Apart from some undercutting of the upper of the two low retaining walls across the gully by run-off water, the intervention was functioning well and in good condition. Grasses had self-seeded between the lava boulders, and these will act to further stabilize the gully. The new Berm 3 will further reduce the flow of water into the NW gully; thus repair to the low wall was not urgent and will be done in 1996.

The exposed area of trackway adjacent to the northwest gully had been covered in 1994 with Enkamat[®], black cotton soil and lava boulders as a temporary protection against natural erosion and foot traffic which, it was noticed, tended to use this area when passing across the site. This covering was partly disturbed between seasons and the Enkamat had been removed (see Part III). The area was re-covered with the same

soil, but without Enkamat, and lava boulders were again laid on the surface running to the lip of the gully.

PROTECTION AGAINST CATTLE

To protect the site from cattle, whose intrusions to Site G cause erosion and damage to exposed tuff outcrops, Maasai elders had suggested, in 1994, the construction of a thorn fence around the perimeter of the site. Construction of the fence, using small *A. drepanolobium* growing in the vicinity of Site G, was completed in 1995 (see also Part XIV). It encloses a buffer area around the trackway following the escarpment to the north, east and south of the trackway.



PART VII. PHOTOGRAPHY AND VIDEO RECORDING

by Tom Moon

INTRODUCTION

Photography at Laetoli for the 1995 campaign was planned and undertaken to complement the work of the two previous campaigns. Because of the much expanded program of re-excavation, conservation, scientific examination, and reburial, the procedures and protocols were necessarily more complete and extensive. Pre-campaign planning included the design of a crossbar and bracket for holding the camera over the trackway for vertical shots, planning for in-camp processing of the photogrammetry plates, planning for the 8x10 in. Polaroid photography, and the design of a consistent procedure for photography of the individual footprints.

Campaign photography included: the general documentation of the site, trackway and personnel; various details of the trackway, footprints, flora and fauna; an extensive 8x10 in. Polaroid flyover series for use in the conservation documentation; the exposure and processing of the 5x7 in. photogrammetric glass plates; assisting the photogrammetry portion of the project and making the 2.25 x 2.25 in. (6 x 6 cm) color transparencies for the color orthophoto mosaic; and the final photography of the individual footprints just before their reburial. Videography was also undertaken.

PHOTOGRAPHIC EQUIPMENT AND FILM

Equipment

Canon F-1N cameras were used as the main documentation tools with 24mm, 35mm, 50mm and 100mm prime lenses (see Appendix A for a full list of equipment). For assisting the photogrammetry, Hasselblad 500C/M cameras were used. One Hasselblad, used for the photogrammetry flyovers, had a prefocused and taped down 80 mm lens mounted on it for the duration of the task, while another one, used for the stereo pair photography of the individual footprints enclosed by the calibration frame, had a prefocused and taped down 40mm lens on it. Multiple exchangeable film backs were used with the Hasselblads.

The individual footprint photography was undertaken with the Canon F-1N using a 100mm macro lens, and by the Hasselblad 500 C/M using the 135mm macro lens with a helical focusing mount. A Norman 200B flash unit was employed for lighting the individual footprints, and a Minolta Flashmeter III and a Minolta Spotmeter for

setting light levels with the flash, and determining exposure settings. Color temperature for the flash pictures was set using a Minolta Color Temperature Meter II with its corresponding flash receptor. All lenses and camera bodies were overhauled and cleaned, and then tested, prior to departure to Tanzania.

The GCI provided a Cambo SCX 8x10 in. camera with a 305mm f/9 Schneider G-Claron, the Calumet Polaroid hand-cranked processor, and the 8x10 Polaroid film holders. The GCI also provided two Hi-8 video cameras, a Sony CCD-TR700 and a Sony CCD-TR500.

Film

Kodak Lumiere 100 Professional color transparency film, an E-6 process film, was used for the entire project in both the 120 format, LPP 120, as well as the 35mm format, LPP 135-36. The "P" emulsion was used because of its neutral color balance. Both film stocks were tested for color balance and effective speed prior to the campaign. The black and white negative film used was Kodak T-Max 100. The T-Max was used only in the 120 format, TMX 100. Additionally, the glass plates used in the photogrammetry were 5x7 T-Max 100 plates. 35mm Kodak Royal Gold color negative film in both 100 and 400 speed were available on site as a snapshot film for incidental photography when negatives and prints were needed. Polaroid Polacolor ER 8x10 Instant Film Type 809 was used in the flyover sequence.

12' Tripod for Photography

The tripod was fabricated in Tanzania by Hoopoe at the request of the GCI (See Appendix B). It provides a high viewpoint for a photographer (Photo 30). It also has a flat top plate drilled for mounting a tripod head, thus making the Hasselblad photography much easier. The tripod has a relatively narrow base for ease in moving it up to the trench, or other location, allowing it to be placed close to the area being photographed below, so that a nearly vertical photograph can be made. The tripod is easily moved by three people, and can be located conveniently anywhere on the site to gain height for documentation. The design and construction made for a very stable stand, while at the same time allowing the tripod to be folded and compactly stored away from the site off season. The tripod proved to be an essential piece of equipment during the campaign, and was used extensively. The only improvement would be to have a safety strap connected to the top for security in the wind gusts which were experienced.

Tripod positions were visually determined by looking through the cameras with the appropriate lenses attached. The Hasselblad images of the trackway re-excavation required slight changes of taking position from the Canon ones. This necessitated moving the tripod during the photography. The shadow of the tripod was a problem. Since the tripod was primarily used on the west side of the trench, photography had to commence early enough in the day to guarantee that the tripod and photographer didn't cast shadows into the trench itself. Shadows became a problem after 1:30 PM, so planning for a series of photographs needed to accommodate this.

Crossbar and Camera Bracket

The crossbar and bracket for holding the camera was designed to accommodate a Cambo SCX 8x10 view camera, an aluminum bracket holding either the Zeiss UMK or the Kodak DCS420 camera, and the Hasselblad (Photo 31). These cameras, with their respective counterweights, range in weight from around 25 kg. (56 lbs) for the Cambo to around 3.6 kg. (8 lbs.) for the Hasselblad. The cross bar and tripods needed to be able to carry this weight safely and stably.

The crossbar is a 12 foot long, 2 x 3 in. in cross section, rectangular aluminum tube. It has 3/8 in. holes drilled through both faces set 2 in. back from each end. These holes allow a 3/8 in. x 16 pitch (European tripod thread) bolt to secure it to the two tripod supports. The tripods selected were two Gitzo #502 tripods, each with a #526 geared center column (See Appendices C1-3).

The bracket assembly rides on the bar on two 16 mm (5/8 in.) ball bearing work rollers. Each bearing is rated to hold 34 kg. (75 lbs.). The bracket is a wrap-around design so that the bar is "captured" making the entire assembly safe from disengaging and falling. After the bracket is positioned, two DeStaco #202-U clamps with nylon cap nuts secured to the clamping ends as pads are locked down to secure the assembly flat against the crossbar. The assembly is held upright in place by the clamping pressure, and laterally by friction. The mechanism is simple and dependable. An extra bearing, replacement screws, nuts, and washers are stored with the bar in Tanzania. The bracket support plate was drilled at the bottom to accept a 1/2 x 24 in. threaded steel rod to hold a Matthews Fly-A-Way Sandbag as a counterweight. This bag (there are two stored in Tanzania) has a Velcro opening. Locally obtained rocks and sand were used to fill it and create a proper counterweight. At the top of the plate is another hole drilled

to accept a 3/8" bolt to secure a Bogen Deluxe Geared Head #3263 to it. This head can pan 360° or tilt in either, of both, of two axes while securely holding a large camera. The geared cranks allow for quick, accurate positioning and leveling.

Four people can move the crossbar and bracket while it is attached to the tripods. Two lift the entire assembly by the bar while the other two attend to the legs of the tripods, adjusting them to level. When moving the entire assembly, it is important to let the tripods hang from the crossbar while level is adjusted in order to avoid twisting and straining the 3/8" bolt juncture of bar and tripod. The bolt is hardened steel, and the platform's receiving threads are tapped into a lightweight alloy. Too much strain could easily strip the threads. Kneepads cushion the feet of the tripod legs on the tuff surface if any protrude into the trench during the leveling and height adjustment. After the crossbar is set to level (the geared head can accommodate for slightly unlevel conditions), all bolts and leg clamps are tightened finger tight. The entire crossbar can then be raised or lowered by two people simultaneously cranking both geared columns. The crossbar, bracket, and attached camera are ready for use after checking the entire assembly for stability.

Trench Canopy

A canopy was constructed to cover a frame that was large enough to enclose the entire trackway (Photos 2, 29). The translucent canopy (Matthews Artificial Silk) provided an evenly illuminated work space under it that was approximately one-and-a-half stops less light than it would have been in the direct sunlight. With the ISO 100 films, this provided a very usable f/8-11 at 1/60 sec. exposure. The long sides of the frame were covered with roll-up, open-weave material.

The canopy also provided a photographically usable color temperature of $5200^{\circ}\text{K} \pm 150^{\circ}$, which matches the nominal color balance of E-6 films. An additional benefit that the shaded area provided was a pleasant and consistent air temperature. The temperature under the canopy remained at a comfortable average of 75°F (24°C). This held the Polaroid film at a stable and optimum processing temperature, making its processing consistent. Additionally, the shade protected the work crews, sensitive materials, and equipment.

GENERAL SITE PHOTOGRAPHY

General site photography followed procedures established in the prior two campaigns. The duplication of earlier views was accomplished using photographs from the prior campaigns and additional information in the logs, such as direction of the camera as taken from a compass, and the height and distance of the camera from some known boundary.

Documenting the site conditions on the return of the Laetoli team was of primary concern the first few days. As the site was cleared, progress was recorded. New camera positions were recorded in the logs for ease in duplicating positions and camera/lens combinations used in sequential photography. The gradual re-excavation of the trenches was recorded systematically from set viewpoints, including from the 12' tripod. As the different teams rotated through the site, their work was recorded and their photographic needs were met. Various visitors to the site were documented. The trees and tree roots were inventoried *in situ* and their interface with the tuff surface was documented. The various tools used on site were documented and shown in use. The sieving of the sand was recorded. Finally, the beginning of the reburial was documented until my departure from the site on August 25, when the other team members took over the photography.

8X10 POLAROID PHOTOGRAPHY

The Polaroid photography used the crossbar and camera bracket assembly to make a complete series of "flyover" shots (Photo 30). The entire re-excavated 1979 trench was photographed to the same scale to create a mosaic overview of all of the trenches. The overview shots each covered an approximate area 85 x 108 cm (33.5 x 42.5 in.) The magnification on the Polaroid was about $M = 0.22$. A total of 30 shots covered the whole of the excavated trenches. In addition, every footprint was photographed individually, surrounded by a reference frame, for use by the conservators in making a condition record. Two different magnifications were used: $M = 0.75$, for the smaller footprints, and $M = 0.49$, for the larger footprints. A total of 29 individual footprint Polaroids were made.

The procedure for the Polaroids was as follows:

- 1 Position the crossbar at the approximate position and height (76.5", 1.94 m above the tuff measured at the center of the crossbar) to locate the 8x10 camera properly for the overviews.

- 2 Locate the first shot, positioning the camera at the approximate height and bellows extension with a measuring tape (lens-to-tuff distance 164 cm; lens-to-film plane 37 cm)
- 3 Level the camera and check the subject position and the focus through the groundglass, using, first, the tripod head positioning cranks, and then, the camera movements.
- 4 Check the focus and re-level the camera with the Polaroid film cassette resting on the back of camera. This takes into account the camera sag due to the additional weight.
- 5 Remove the cassette from the camera, and take it to the processing station. Insert the cassette into the pre-loaded processor and crank the negative-receiver sheet sandwich through. Time the processing, and peel apart the carrier sheet from the negative. Dry the print.
- 6 The flyover sequence takes 3 or 4 shots. After each photograph is approved, the camera bracket is laterally moved on the crossbar 78 cm (30.75 in.) to place the camera at the next position.
- 7 After the flyovers are completed, the tripods are lowered and re-positioned for the individual footprint photography. The bar height for these is 93 cm, measured in the center of the trackway, with a lens-to-tuff distance of 68 cm for the small frames, and 90 cm for the large frames. The individual photographs require frequent re-positioning of the entire tripod, crossbar, and camera assembly.
- 8 After these exposures, the bar is moved forward 98 cm from the crossbar position of the flyover, and the entire procedure begun again.

Each exposure required, on average, approximately 22 minutes.

The Polaroid photography was successful, in spite of the fact that the film is not really designed to work at long exposures. Polaroid Type 809 film is designed for use with electronic flash or at relatively short exposures. The slow shutter speeds of 1/2 and 1 second, necessary for adequate depth of field in our use, caused excessive reciprocity law failure. The effective film speed was reduced from ISO 80 to around ISO 20 for the second exposure, and around ISO 16 for the 1 second exposure. Massive color correcting filtration was needed, CC50R and CC15M, to achieve an adequate color balance. The manufacturer's suggested settings and filtration were subject to additional corrections to achieve a good compromise. The results were adequate for their use in notetaking.

Processing the Polaroid film in the field proved to be relatively easy. The rollers of the processor, the Calumet manual feed processor, did require constant cleaning, mainly to remove processing chemicals, but this, although time consuming, is easy. The 8x10 camera case doubled as a convenient "dustfree" drying cabinet for the prints.

PHOTOGRAMMETRY

Assistance to the photogrammetry team was provided as follows:

- design and fabrication of the plan for the crossbeam support and bracket for the cameras used in the flyover photography.
- exposure measurement and processing of the glass plates for the Zeiss UMK camera.
- providing Hasselblad cameras and lenses for making various exposures to supplement the main Zeiss UMK and Kodak DCS420 ones.
- procuring and planning for exposure and processing of Kodak T-Max 100 glass plates. Some 4x5 T-Max film was exposed and processed prior to leaving the US for Tanzania to check film speed and processing times. An exposure index of either 100 or 80 gave excellent results. The exposure of the plates was determined by using a light meter, the Minolta Spotmeter F, for reading a gray card in the plane of the tuff.

Kodak developer D-76 was chosen for processing the plates since it is a recommended developer for T-Max, and also because it comes packaged in powder form, and is, therefore, much more easily handled and transported than the primary recommendation, Kodak RT liquid developer, or the other recommendation, developer HC-110. The D-76 can be readily used as a non-replenished tank developer, while the RT liquid developer is designed for use in a replenished processing machine. Locally purchased white vinegar was used for the acetic acid stop bath, diluted, by volume, one part vinegar with two parts water (as per Haist, Grant, *Modern Photographic Processing: Vol. 1*, New York, 1979, p. 552). Kodak powdered fixer was used as the fixer, and Kodak Hypo Clearing Agent as a wash aid. On site, water was filtered for mixing the chemicals and washing. It was prefiltered in a Delta polyethylene filter that has a stainless steel metal screen integral with the spout. This mesh removed the gross particulate matter. The water was then filtered through a Whatman filter paper to remove the remainder of the dirt and other smaller particles. A 13 gallon (50 liter), polyethylene container with a spigot at the bottom was used to hold the water after filtering. The chemicals were stored in disposable photographic chemical containers during use.

The processing tent took time to set up adequately. Camp Manager, Augustine Mtemi, located a storage tent made out of heavy canvas that provided enough opacity. A tarp was placed under the tent as a floor, overlapping up the side walls. An second fly was draped over the tent body extending to the ground on each side. The perimeter, at ground level, was held securely in place with logs. Additionally, two more flies were used, one at each end to cover the door panels, and to assure a fairly dark interior. Two tables were placed inside, one to process the plates on, and another one, kept dry, to load and unload the plates holders. Flashlights were used for a worklight. Light leaks were taped over from the inside with duct tape; black gaffer's tape is more opaque than duct tape, and would make the job easier requiring a single, rather than multiple tape layers.

Processing followed Kodak guidelines. Kodak Hard Rubber Tanks for 5x7, each holding one gallon of solution, were used, one tank each for developer, stopbath, and fixer, and a fourth, for holding the plates prior to processing, and after fixing, for washing. The processing tanks were filled with only 112 ounces (3.3 liters) of the solutions to accommodate the displacement of the liquid by the plates and hangers. Temperature control was minimal, but adequate. Processing solution temperatures were adjusted to be within a few degrees of each other and the wash water. Since the ambient temperature varied so much during the days and nights that we processed, the temperatures were not the same during each processing run. The developer was adjusted to be in the 70-75° F. (22-25° C.) range and processed according to the time and temperature chart. The negatives were made for scanning and not pictorial use, so there was latitude allowable. Since the developer was not replenished, an additional 10% time was added to the developing time of each succeeding batch. This additional time, as recommended by Kodak, seemed to be a bit excessive as seen in increased density of the plates, but it was functional. Since the developer can accommodate 32-5x7 plates per gallon, two gallons of developer were mixed and used. Both the stopbath and the fixer were well within their capacities, so only one gallon each of them was used (Capacities as stated in Kodak, *Practical Processing in Black and White Photography*, Kodak Publication P-229, Rochester, 1972, pp 11, 17).

The procedure for processing was as follows:

- 1 Load the plates into the hangers, emulsion side facing "front."

- 2 Tell assistant to start the timer while simultaneously lowering the negatives into the developer.
- 3 After immersion, immediately begin lifting and replacing the hangers in the solution using alternating side tilts for the first 60 seconds of development.
- 4 For the remaining time, the timer calls out at one-minute intervals the agitation cycles. These are two complete lift and tilt cycles (total of four lifts, two tilts each side taking 15 seconds each complete cycle).
- 5 Fifteen seconds before the end of the processing time, the timer calls out. The hangers are lifted and the plates drained of excess solution. When the countdown timer signals the end of the development, the plates are lowered into the stopbath and continuously agitated for 30-60 seconds.
- 6 At the end of the stopbath, the plates are drained and then placed into the fixer for four minutes with continuous agitation.
- 7 At the end of fixing the plates are drained and placed into the holding tank. They are now removed to the outside of the tent for washing.
- 8 First, the plates, hangers, and tank are rinsed off by filling the tank with water to overflowing. The hangers are continuously agitated for four minutes. The tank is emptied and Kodak Hypo Clearing Agent is poured in. The hangers are again agitated for four minutes. After this the plates are drained and then washed in four successive, four minute washes with agitation, carefully draining away the wash water each time. After the final wash the tank is refilled with water into which eight drops of Edwal LFN wetting agent are added. The plates are gently agitated in this solution for a minute, drained, and then placed in an empty 3 gallon processing tank to dry, tilting the tank so that the plates are at an angle allowing the water to run down to the lowest corner and drip away.

This procedure was followed for all the processing runs and produced negatives of excellent gradation and tonal range. The plates were repacked into their original boxes using the spacers and cushioning materials for travel.

Additional images were made for photogrammetry using Hasselblad cameras with taped down lenses preset for focus. The flyovers and the calibration frame pictures were both made using Kodak Lumiere 100 film. The flyover pictures used a Hasselblad 500C/M with an 80mm lens. The individual footprint pictures used a

Hasselblad 500C/M camera with a 40mm lens. All exposures were determined using a gray card in the tuff plane read with the Minolta Spotmeter F set to ISO 80.

PHOTOGRAPHY OF THE INDIVIDUAL FOOTPRINTS

The photography of the trackway footprints was undertaken after the completion of the final conservation of the campaign.

The photography of each of the individual footprints was made at the same scale. That is, the largest footprint was accommodated within the camera frame, and then all the others were photographed at the same magnification. The tripod was taped securely at this camera height, and only the lens barrel was adjusted to accommodate focusing. A leg would be adjusted to accommodate very uneven tuff surfaces, as when the photography was at the south end of the trench. At all other times the tripod was left at its established height. The 35mm magnification is $M=0.07$, and the 6x6 cm is $M=0.11$.

The same lens and body combination was used throughout the photography. For the 2.25 in. (6cm) photography, a Hasselblad 500C/M body was used in conjunction with a helical focusing mount and the Hasselblad-Zeiss 135mm Makro Planar lens with a lens shade. For the 35mm photography, a Canon F-1N camera body with a motor drive and a Canon 100mm macro lens was used.

The color transparency film used for both formats was Kodak Lumiere 100 LPP film. This film has a neutral color balance, moderate speed, and high resolution. Additionally, Kodak T-Max 100 film was used in the Hasselblad format for making black and white negatives of each footprint. In all the color footprint photography, bracketed exposures were made to insure the best possible rendition.

The canopy provided an even source of fill light at an optimum color temperature. The light was $5200^{\circ}\text{K}\pm 150^{\circ}$ during the hours when the canopy illumination completely covered the trackway, between the hours of 9:30 am - 3:00 pm. The base exposure for this fill light was 1/60 sec at $f/8.5$ to 1/60 sec at $f/11.3$. The base exposure "peak" occurred when the sun was directly over the canopy. A Norman 200B flash unit was used with a Norman LH2 lamphead with a 2D reflector as the main light. This flash was adjusted to 5200°K in combination with the fill light, at a 3:1 lighting ratio, with strips of Rosco filters. The 3:1 light ratio was used to ensure that the

shadows were all "open" and that the highlights and shadows would all be in an exposure range compatible with the transparency film. The flash was placed on a small light stand approximately half-way between the longitudinal and transverse axes of the footprint aiming approximately 45° downward to the plane of the tuff. This gave an "architectural" lighting which would accommodate the varying depths, ridges, and textures of the footprints. In other words, a standard lighting geometry was established so that each and every one of the footprints was lighted in a consistent manner, and from the same angle, so that all could be viewed similarly. Each one would have the same visual characteristics as all the others.

During the Hasselblad sequence, one additional series took place, that of footprint G2/3-25 which was photographed before, at the halfway point, and at the conclusion of cleaning away the Bedacryl layer.



APPENDIX A

EQUIPMENT LIST FOR LAETOLI PROJECT, JULY-AUGUST, 1995

2 CANON F-1 BODIES.
3 CANON F-1N BODIES.
3 CANON AE MOTOR DRIVES FN.
CANON LENS FD 24mm F/2.8.
CANON LENS FD 35mm F/2.
CANON LENS FD 50mm F/1.4.
CANON LENS FD 300mm F/5.6.
CANON MACRO LENS FD 50mm F/3.5.
CANON MACRO LENS FD 100mm F/4.
CANON EXTENSION TUBE FD25.
CANON EXTENSION TUBE FD50.
GITZO TRIPOD WITH R2 HEAD AND EXTENSION ARM.
GITZO MONOPOD.
MINOLTA SPOTMETER F.
MINOLTA FLASHMETER III.
MINOLTA COLOR METER II.
MINOLTA COLOR METER II FLASH COLOR RECEPTOR.
2 VIVITAR 285HV ELECTRONIC FLASH UNITS.
FLEXFILL REFLECTOR, 52" X 28".
PHOTOFLEX REFLECTOR, 22".
PHOTOFLEX REFLECTOR, 12".
VARIOUS FILTERS AND FILTER HOLDERS.
2 SMALL TOOLBOXES WITH VARIOUS TOOLS AND ACCESSORIES.
2 SMALL LIGHT STANDS.
VARIOUS LIGHT STAND ACCESSORIES AND CLAMPS.
HASSELBLAD 500C(M) CAMERA BODY.
HASSELBLAD 500C/M CAMERA BODY.
5 HASSELBLAD A12 FILM MAGAZINES.
1 HASSELBLAD A16 FILM MAGAZINE.
HASSELBLAD 40mm F/4 LENS.
HASSELBLAD 80mm F/2.8 LENS.
HASSELBLAD 120mm F/5.6 LENS.
HASSELBLAD 135mm F/5.6 LENS.
HASSELBLAD BELLOWS.
HASSELBLAD PRISM FINDER.
HASSELBLAD FOCUSING TUBE.
HASSELBLAD EXTENSION TUBES 10 AND 21.NPC MODEL MF-1 POLAROID BACK FOR HASSELBLAD.
2 HASSELBALD PROFESSIONAL LENS SHADES.
VARIOUS CAMERA ACCESSORIES.
2 NORMAN 200B POWER PACKS.
2 NORMAN LAMPHEADS. LH2K & LH2.
2 NORMAN RECHARGERS.

APPENDIX B

THE 12' TRIPOD.

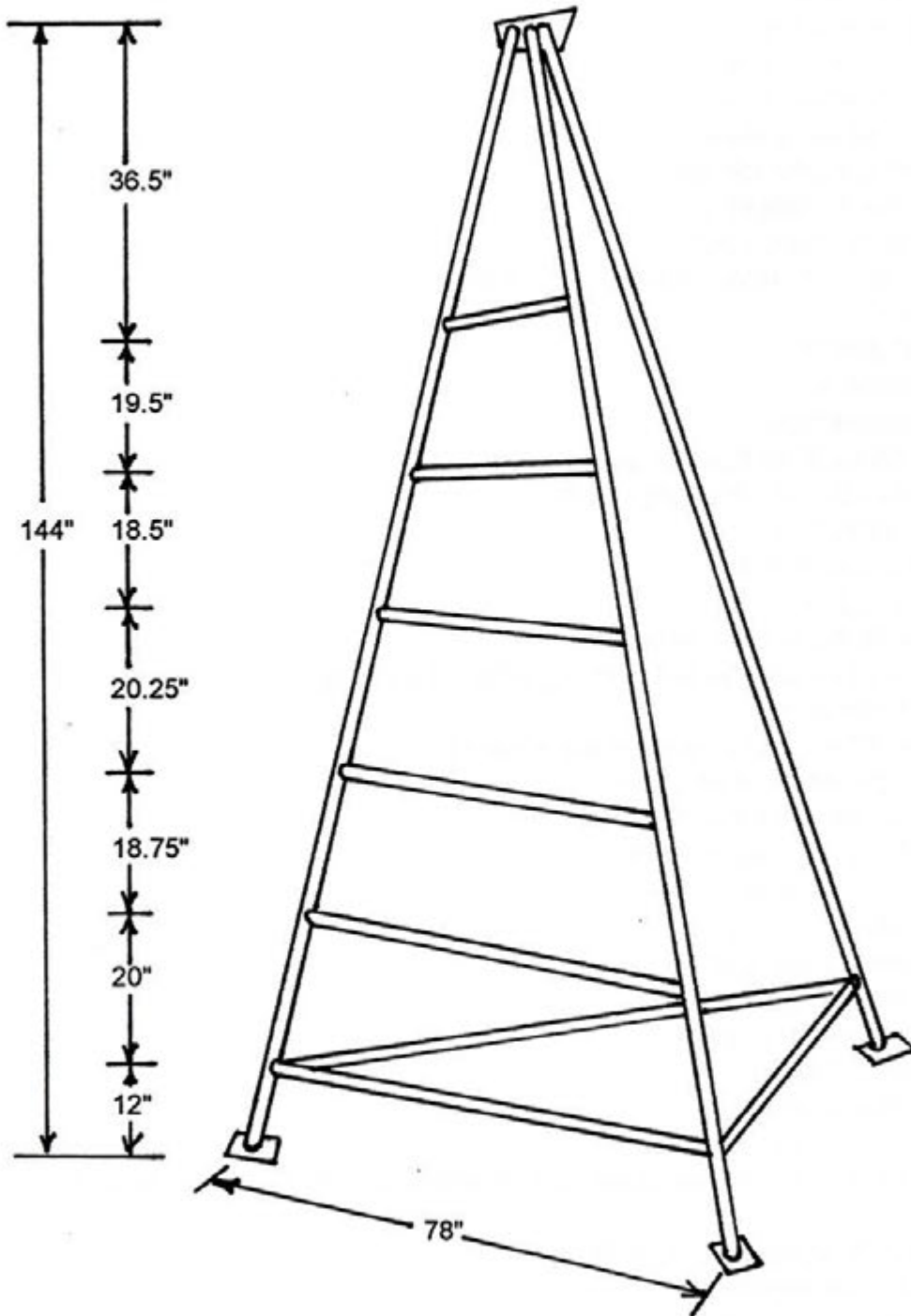

APPENDIX C-1

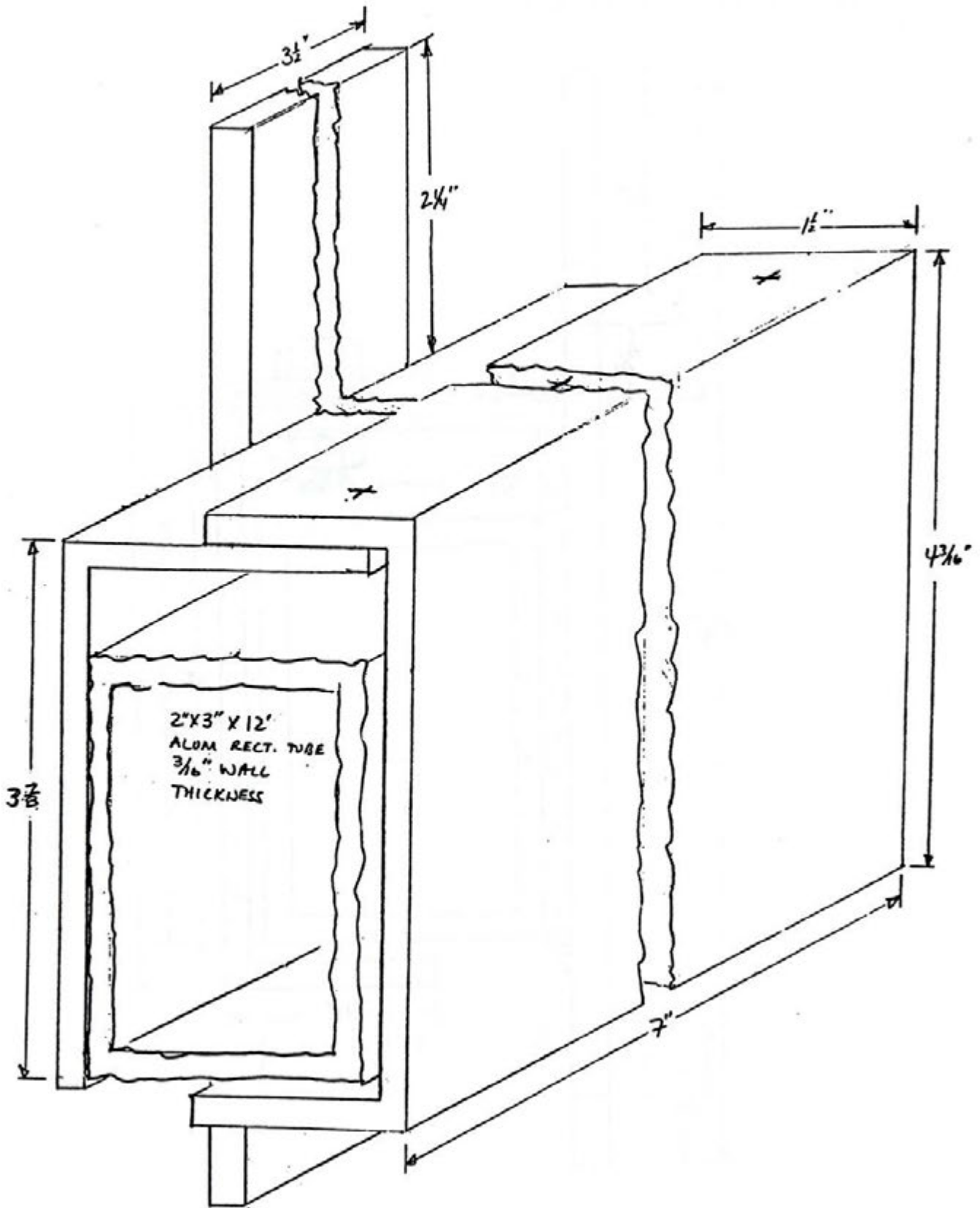

Fabrication drawing of the camera bracket, oblique view.

APPENDIX C-2

Fabrication drawing of the camera bracket, end view.

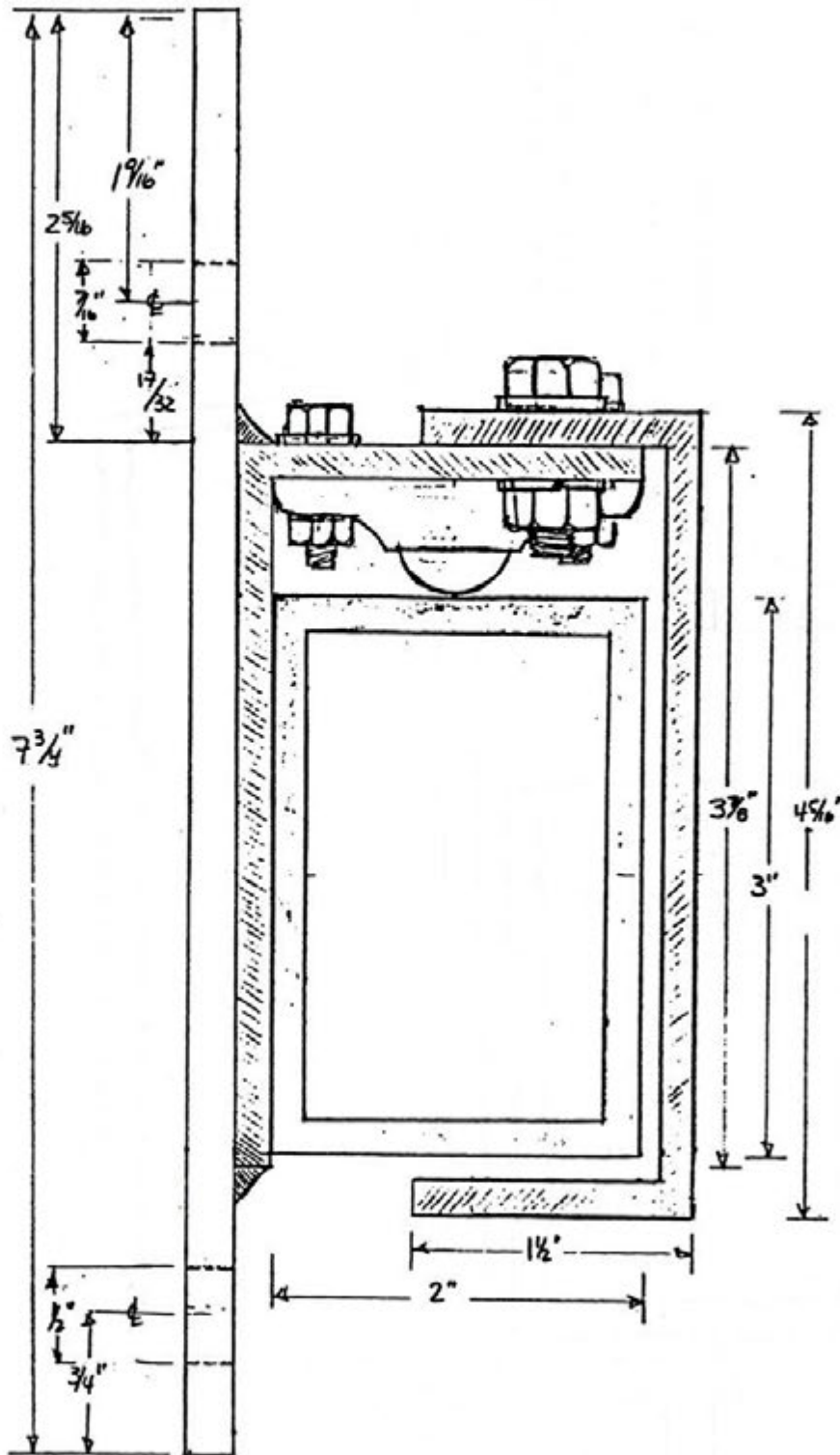

END VIEW

APPENDIX C-3

Fabrication drawing of the camera bracket, top view.

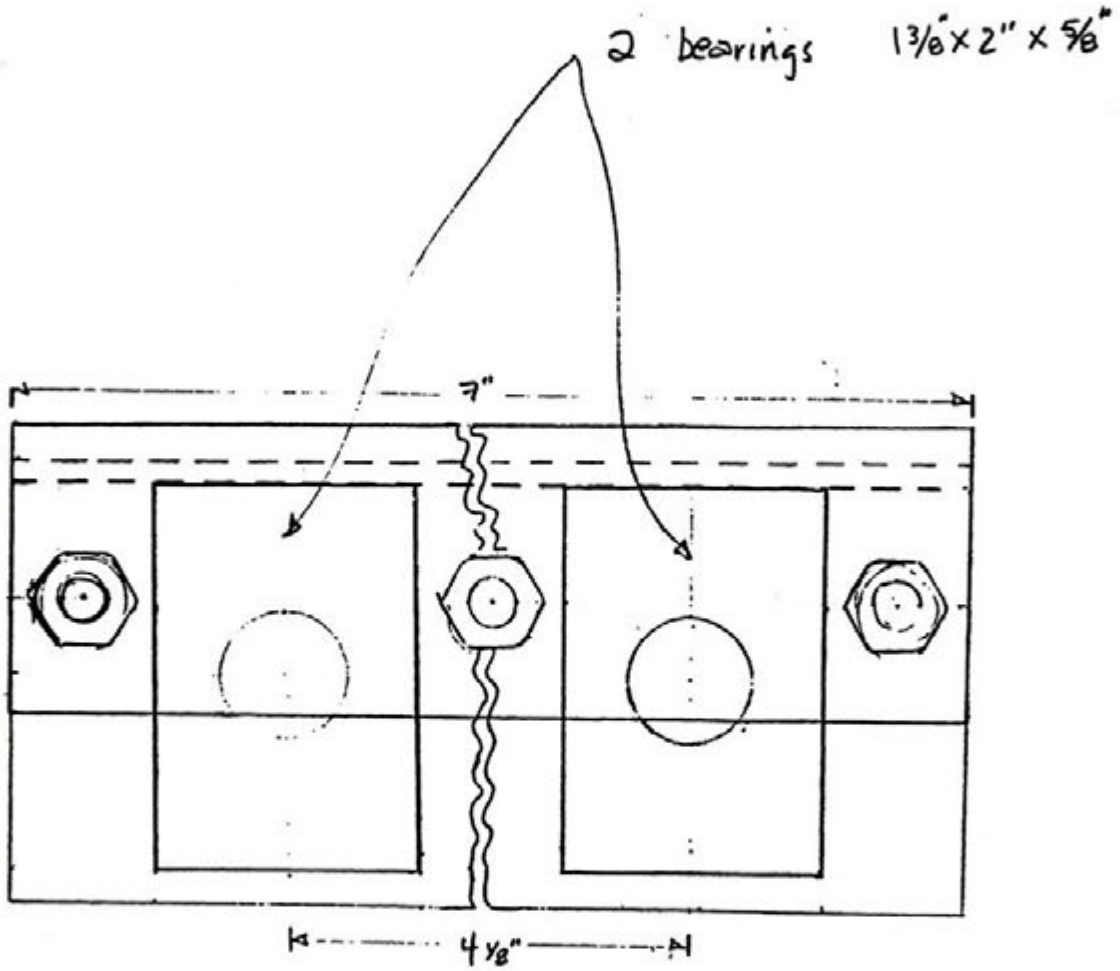

TOP VIEW SHOWING BEARING POSITION-

PART VIII. AIMS OF THE PHOTOGRAMMETRIC DOCUMENTATION

by Gaetano Palumbo

The re-excavation of the trackway at Site G for the first time after the original excavation by Mary Leakey in 1979 was a unique opportunity to record the site with a precision that could not be achieved with the technical means available to the Leakey team. A photogrammetric plan of 23 footprints in the southern trackway had been developed at the time of the original excavation, but the way photography of the footprints and mapping of the site had been performed did not allow the generation of an accurate plan. It is estimated (Salamonowicz 1983) that the precision achieved by the 1979 photogrammetric record of Laetoli site G is less than 3 cm, and that "a plot of the site at a 1:4 scale with a 5 mm contour interval is achievable" (Salamonowicz 1983:66). This comment however implies that:

1. Since 5 mm contours is the maximum achievable with the 1979 data, then the 1 mm plots generated from those data (F and published by Jones in Leakey and Harris 1987: 551-558 are an extrapolation only, and were not produced on the basis of effective measurements;
2. 1:1 scale plots cannot be produced, given the large error of the baseline data, with the 1:4 scale drawings the best obtainable result;
3. The fact that the precision is not better than 3cm means that features such as axis of the footprints, orientation and reciprocal distance of the imprints are unacceptably approximate. These features are very important for any study on locomotion and gait, and their precision is essential to this aim.

These three arguments alone were sufficient to justify the repetition of the photogrammetry of the site.

The aims of documentation were then:

1. To produce a very accurate record of the hominid trackway by using close range, sub-millimeter photogrammetry;
2. To use the data obtained to produce contour maps of the site and the individual footprints with a precision of less than 0.5 mm, and contour distances of 5 mm for the general trackway and 1 mm for the individual footprints (see Figs. 7, 14);

3. To produce orthophotographs of an extensive area of the southern trackway and the individual footprints;
4. To allow scientists and conservators to use the baseline data (contour maps and orthophotographs) for their aims, maintaining an integrated system of data collection and display;
5. To integrate the data obtained into a management system to allow manipulation, analysis, and retrieval of information derived from a variety of sources, such as condition reports, excavation records, scientific observations, etc.

The photogrammetric documentation of the site was conducted in two phases: fieldwork and post-processing of analog and digital data. The work in the field, presented by Prof. Rüther in his detailed report in Part VIII, consisted of four basic steps:

1. The preparation and survey of a series of control points in order to place the site in a local grid system, and achieve the required sub-millimeter precision
2. The photography of the southern trackway using three camera systems: photogrammetric camera (UMK) with 5x7 glass plates, transparency film in 2.25 x 2.25 in. format (Hasselblad) and digital images (Kodak DCS400) at a resolution of 1000x1500 pixels. The site was photographed from a crossbar spanning the trackway. 80% horizontal and vertical overlap among adjacent photos ensured proper coverage for the later generation of the digital terrain models.
3. Photography of each single footprint using the Hasselblad and Kodak DCS cameras from a distance of 0.6/0.7 meters. Each footprint was photographed surrounded by a special metal frame with control points which were surveyed prior to each photo session.
4. Processing in the field of the glass plates to ensure their quality, and revision of the digital files on a laptop computer.

The work in the laboratory included the creation of contour plans for the trackway and each individual footprint, using automatic and manual methods, and the generation of digital elevation models (DEM) for each of the footprints and for the entire trackway. These data were then translated into AutoCAD and ARC/Info exchange files.

The actual digital images were also processed, in order to obtain orthophotos of each footprint and of the entire trackway. The entire process involved the generation of over 30,000 files, for a final result of close to 2,000 files and 4 gigabytes of data.

All files were imported directly from a server in South Africa using FTP software. Downloading of the files was performed mostly overnight or during the weekends to take advantage of faster connection speeds. Once downloaded, files were decompressed and verified for integrity. Archival files were stored on CD-ROMs, while AutoCAD and ARC/Info exchange files were imported into those programs to create drawing files and GIS coverages. These and the orthophotos will constitute the main corpus of operable data, while the archival files are preserved for future reference.

The generation of the baseline data will also be accompanied by experiments in visualization techniques, for both presentation and scientific analysis. These experiments include surface rendering, stereo imaging, and draping of vectors onto rasters, using a variety of software packages and techniques. In this case also, the aim is to provide scientists and the wider public with data that can be further manipulated and analyzed.



PART IX. REPORT ON THE PHOTOGRAMMETRIC FIELD CAMPAIGN

by Heinz Rüther

1. INTRODUCTION

In order to produce a permanent record of the hominid trackway site at Laetoli, Tanzania, the Getty Conservation Institute contracted a team from the Department of Surveying and Geodetic Engineering at the University of Cape Town (UCT) to carry out a digital/analytical photogrammetric survey of the site. The work was carried out in three stages:

- project design (a project design document was prepared earlier)
- field work and
- post processing

The following report gives details of the field campaign, describes the data processing strategy and reports on the results to date. All relevant coordinates of survey points, photogrammetric control points and calibration frame points are provided in the report to make it possible to allow for the re-evaluation of the photogrammetric data in the future, should new technologies and advanced algorithms become available.

The photogrammetric field campaign was carried out in Laetoli from the 6th to the 18th of August, 1995. The data processing stage began immediately after the return from Tanzania and a set of results was completed in February 1996. However, further work on the images is ongoing and expected to keep photogrammetric researchers occupied for some time to come.

The UCT field team had two members:

UCT Field Team		
Heinz Rüther		project leader
Julian Smit	Ph.D. student	scientific field assistant

In Laetoli the team was joined by Dr. Gaetano Palumbo and scientific photographer Tom Moon. The assistance of these two additional team members was invaluable and without their help and advice the work could not have been completed in the time available.

The UCT data processing team was comprised of:

UCT Data Processing Team		
Heinz R��ther		project leader
Susan Binedell	Senior Technical Officer	DEM generation from UMK images on analytical plotter, Arc/Info files
Julian Smit	Ph.D. student	digital photogrammetry
Ulrike Br��ssler	MSc student	DEM generation from digital images, data management
Henty Waker	MSc student	digital ortho -image generation
Siddique Motala	MSc student	image processing

2. OBJECTIVE OF THE FIELD CAMPAIGN AND EXTENSION OF ORIGINAL WORKING AREA

It was the objective of the field campaign to acquire complete photogrammetric coverage of the 29 individual footprints in the southern trackway and extensive coverage of the surrounding tuff surface. The photography was to be executed with digital and conventional cameras. Each of the images had to contain a sufficient number of control points of sub-millimeter accuracy to enable the generation of digital terrain models with contour intervals of 5 mm and 1 mm for the trackway and the foot-prints respectively. Accuracies of individual points had to be in the order of 0.5 mm.

On inspection of the trackway it became obvious that an important part of the exposed trackway would not be covered by the photogrammetric images originally requested. This was the area containing the two hipparion trackways crossing the hominid trackway in a north-easterly direction and the small carnivore trackway crossing the hominid trackway at approximately right angles in the northern part of the exposed section. The photogrammetric survey was extended to cover the section of the exposed trackway immediately to the east of the hominid trackway. The extent of this added area is approximately 4 m by 1 m.

The additional area increased the number of required control points by 8 and the number of images by 56. In order to accommodate this additional demand on photographic material as well as surveying and photographic processing time, it was decided to omit the originally planned duplication of UMK 10 photography at a different exposure, provided the first UMK 10 results proved satisfactory. This change

of plan was adopted when the UMK 10 photography did in fact prove to be of such a high quality that no improvement could be expected from a second set of images.

3. PREPARATIONS

3.1 Form sheets, spreadsheets and computer programs

Prior to fieldwork the following documents, spreadsheets and computer programs were prepared:

- a spreadsheet to record and reduce the survey control point observations (vertical and horizontal angles)
- a spreadsheet to record and reduce the observations for the photogrammetric control points
- a least squares network adjustment program for the evaluation of the point positions of all control points
- form sheets for the recording of the photography.

Separate sheets were prepared for the UMK 10, the DCS 420 and the Hasselblad photography and form sheets were prearranged in folders to provide one sheet for each image. However, during the field work it became obvious that the information recorded was repetitive as photographic conditions remained constant during the photographic sessions. This was largely due to the very efficient shelter erected over the trackway. Recording sheets were therefore combined and more than one image was recorded on many of the sheets.

3.2 Mechanical devices

Mechanical devices build in preparation for the field work were:

- a support frame with mounts for the UMK 10 and the DCS 420 allowing for a vertical separation of 30 cm between camera lenses
- a frame with 70 retro-reflective targets (6.2.1). This frame doubled as a calibration field for the DCS and Hasselblad cameras and as a control field for the footprint photography control and survey point markers
- a horizontal camera support bar, straddling the trackway was designed and manufactured by Tom Moon (see Part VII and Photo 31).

3.3 Tests and simulations

Tests and simulation surveys carried out in preparation for the field work were:

- simulation of the footprint photography and DEM generation by photographing a footprint in a sand box using equipment and procedures as close as possible to the conditions anticipated for Laetoli. Both the photogrammetric imaging and the DEM generation proved fully satisfactory.

- least squares pre-analysis of a control point field as planned for the track. Predicted accuracies were better than 0.5 mm.
- there was some concern regarding the suitability of vertical angle measurements (as opposed to precise levelling) for the determination of control point heights with an accuracy better than 1 mm. Pre-analysis and a complete survey simulation confirmed that the required accuracies could be achieved by vertical angle measurement. This was later borne out by the results of the actual field survey.

4. ENGINEERING SURVEY AND PHOTOGRAMMETRIC SURVEY PROCEDURES

The field survey of the Laetoli hominid footprint trackway can be divided into three fieldwork components:

- the establishment of a datum (reference coordinate system) by means of survey control points
- a conventional high precision survey of photogrammetric control points on the trackway
- the acquisition of photogrammetric images

In the following, these procedures will be explained.

4.1 Establishment of a datum and description of the coordinate systems used on site.

Two co-ordinate systems were originally established, one for the archaeological survey and one for the photogrammetric survey. These two systems were integrated during the fieldwork to form a single co-ordinate system.

The two systems used were:

i - The Archaeology or A-System

The 'Archaeology system' was established during the first re-excavation of the trackway for assessment in 1993.

datum : the survey datum was defined by the 100_A/100_A point of the excavation grid.

Y_A-axis : positive to the (approximate) south

X_A-axis : positive to the (approximate) east

The north direction for the site was established by a compass reading and can therefore only be accepted as approximate.

ii - The UCT or U-System

The 'UCT-system' was used by the photogrammetric team for the control point survey as a temporary coordinate system.

datum : the system origin was chosen to be E2, one of the existing points established during the first site survey by Mary Leakey in 1978/9.

X_U -axis : positive from E2 toward the newly positioned point E1

Y_U -axis : at a right angle to the X_U axis with its positive direction across the track (in westerly direction).

The UCT system is not used in the main body of this document, but point positions are quoted in this system in some of the project documents where survey calculations are recorded.

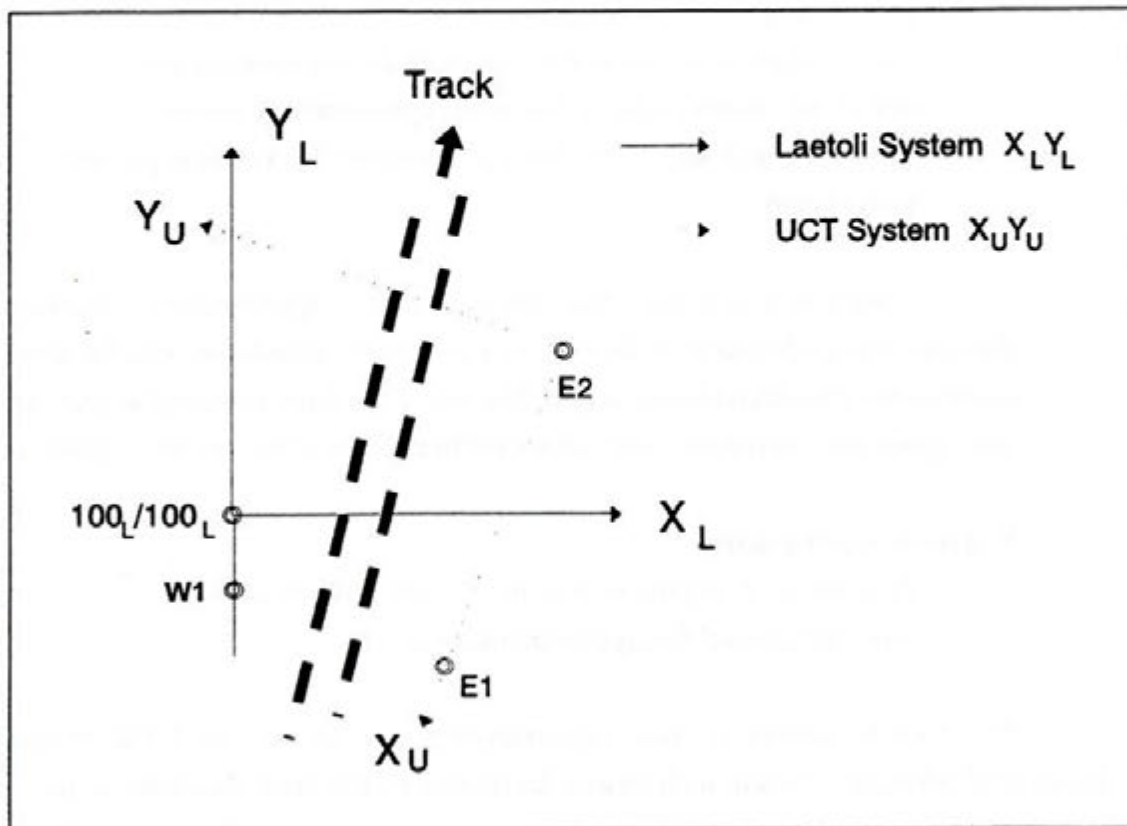

Figure A Co-ordinate systems at Laetoli

iii - The Laetoli or L-system

The two systems were integrated to form a consistent new system for both the archaeological and photogrammetric survey. The new system was chosen to be:

- convenient for CAD and other computer representations,
- similar to the UTM system,
- as close as possible to the archaeological system.

The new system will be referred to as the 'Laetoli' or L-system in this document.

The L-system is defined by:

datum :

The Laetoli system made use of the existing archaeological grid and adopted the $100_A/100_A$ point of this system as a datum, retaining its coordinate values as $100_A/100_A$.

Y_L -axis or 'northing'- axis:

The Y_L axis was chosen to coincide with the north-south grid line of the archaeological system as represented by points $100_A/100_A$ and $100_A/103_A$. For the L-system the Y-axis is positive to the north.

It must be noted again that this axis is only approximately aligned with the north-south direction as the only available north orientation was the compass orientation of the archaeological grid. The use of the term 'northing' is thus merely descriptive and convenient and not meant to indicate a 'true north' orientation.

X_L -axis or 'easting'-axis :

This axis is at a right angle to the Y_L axis, with its positive direction toward the approximate east.

The Laetoli system is thus approximately parallel to the UTM (Universal Transversal Mercator) system with its axes increasing in the same direction as the UTM axes. The north axis also coincides approximately with the track direction, i.e. northing coordinates increase in walking direction.

4.2 Method and procedure for the engineering survey of the photogrammetric control points.

4.2.1 Placing of the photogrammetric control points

The planned 42 control point markers -- metal disks with a diameter of 12 mm and a thickness of 2 mm -- were temporarily attached to the tuff surface using a removable adhesive. The markers were painted black and a self-adhesive retro-reflective disk with a diameter of 6 mm was attached to the approximate center of each disk.

The points were aligned in two rows of 17 points each on either side and approximately parallel to the hominid track. The left and right row are referred to here as row L and row R respectively. A third parallel row (row FR) of 8 targets was placed east of row R to cover the hipparion trackway. The separation between the three rows was approximately 95 cm and the distances between points in along-track direction approximately 45 cm. Targets were placed by inspection and not by precise surveying, as the tolerances for target positions were not critical, with the only condition that the points had to be visible in the photography. Nevertheless, an attempt was made to place the targets in the approximate positions as predetermined in the original control point design (see figures B and C). It was later found that no point had been placed more than 40 mm from the design positions and all points were within the field of view of the cameras as planned. The following table shows how the control points were labeled for each of the three rows.

row	control points	number of points
L-row (west row)	TL1, TL2 ... TL17	17
R-row (east row)	TR1, TR2 ... TR17	17
FR-row (east of R-row)	TFR1, TFR2 . TFR17	8
		Total: 42

Table 1 Control point layout

The final coordinate list (4.3.1-3) gives the surveyed positions of the 42 control points, together with the three survey reference points (E1, E2 and W1) and additional survey points, which had been established in previous surveys and were resurveyed by the UCT team.

4.2.2 Triangulation of survey control point triangle and data processing.

In order to determine the photogrammetric control point positions with sub-millimeter precision, three external survey control points were chosen from which horizontal and vertical angle observations were carried out using a Leica TC 1010 and a Leica TC 1000 single second theodolite. The three external control points were:

- E1 A new point was placed in the south-east corner of the 1995 excavation area, outside the exposed trackway, and marked with a center-punched brass stud in cement.
- E2 An existing point, placed during the first excavation in 1978/9, was reused. The original point, a decaying wooden peg, was replaced with a center-punched brass stud in cement.
- W1 A center-punched brass stud in cement was established adjacent to the archaeological grid point 100_A/97_A at E100/N96.96.

A full triangle observation, including all horizontal and vertical angles as well as all distances (triangulation) between the three points, was executed using data loggers for the survey. The observations were reduced in the camp in the prepared spreadsheet in accordance with standard survey methods.

Later the reduced observations were entered into a least squares survey network adjustment. The adjustment results are excellent with point position precisions better than 0.5 mm.

4.2.3 Triangulation of the photogrammetric control points

The 42 photogrammetric control points were triangulated (using vertical and horizontal angle measurement) from the three survey control points E1, E2 and W1, using a Leica T C 1010 and a Leica TC 1000 theodolite. Distance measurements were not possible as neither instruments nor prisms could be placed on the track.

The control point disks were measured by pointing at the targets in the following sequence:

1. left edge - horizontal angle
2. right edge - horizontal angle
3. far edge - vertical angle
4. close edge - vertical angle

The mean of observations 1,2 and 3,4 provided angle readings to the disk center in horizontal and vertical direction respectively. This observation approach was adopted as it was not possible to estimate and point directly at the disk center with sufficient accuracy.

Observations to most of the 42 disks were carried out from all three stations, thus providing three redundancies for each point. Four disks (TL4, TR16, TR17 and TFR5) could only be seen from two survey stations. In these cases only one redundancy was provided. However, with six control points visible on each image, the overall number of photogrammetric redundancies was so great, that sufficient reliability and accuracy was achieved by this survey design.

The observations were reduced in a second predesigned and tested spreadsheet. The same spreadsheet served to provide provisional coordinates as required for the least squares adjustment. After the completion of the least squares network adjustment, the spreadsheet was employed again for the determination of precise point heights based on the point positions evaluated in the adjustment and the vertical angle measurements to the disk centers. Again the adjustment results were excellent and precisions in the order of or better than 0.5 mm were achieved.

4.2.4 Height determination and height datum

When determining heights by vertical angle measurement to a precision better than one millimeter, the standard method of measuring instrument heights is not suitable due to its limited accuracy. To overcome this problem an approximately 3 m long wooden plank was placed in an upright position close to the site and secured with ropes and a concrete base for the duration of the campaign. A 1 m long metal scale (part of a precise tape) was firmly attached to the plank. Every time a theodolite was set up and before vertical angles were observed, a measurement to the scale was taken with the vertical angle set to $90^{\circ}0'0''$ and $270^{\circ}0'0''$ in circle left and circle right position respectively. The mean of the two scale readings was accepted as the instrument height

above scale zero.

The arbitrary datum thus established is here referred to as the H-datum. Scale readings were taken every time a theodolite was set up, thus providing precise instrument heights for all setups. The readings were repeated at regular intervals during a setup to guarantee that any accidental movement of the instrument would be noted. Inspection of the height values, as determined from the three stations E1, E2 and W1, show excellent agreement with standard deviations better than 0.5 mm, thus confirming the effectiveness of the survey design.

The site height datum was later reduced to the height of point S, a point previously determined by a surveyor and given the height of 51.72. This datum transfer guaranteed a match between existing height values and the new survey. This height system, named the S-system, is not related to mean sea level.

4.3 Point coordinates in the l/s coordinate/height system

The following tables show coordinate lists of the survey control points, the photogrammetric control points and the survey points from the previous site survey in the new Laetoli system with S-system heights (L/S-system).

4.3.1 Survey Reference Points

Name	X _l	Y _l	Height
E1	104.0741	93.4860	51.2587
E2	105.9803	103.2516	51.3988
W1	100.0000	96.9607	51.2111

Table 2 Reference points

4.3.2 Photogrammetric control points

Name	X _t	Y _t	Height
TL1	101.6094	94.2246	50.9994
TL2	101.6234	94.6771	51.0320
TL3	101.6451	95.1572	50.8720
TL4	101.6942	95.5803	50.8833
TL5	101.7401	96.0247	50.8988
TL6	101.7617	96.4889	50.9182
TL7	101.7937	96.9177	50.9348
TL8	101.8704	97.3689	50.9642
TL9	101.8857	97.8284	50.9777
TL10	101.8996	98.2702	50.9959
TL11	101.9637	98.7029	51.0187
TL12	102.0097	99.1568	51.0498
TL13	102.0588	99.6073	51.0792
TL14	102.0723	100.0537	51.1024
TL15	102.1220	100.4956	51.1143
TL16	102.1454	100.9479	51.0729
TL17	102.1922	101.4109	51.1049
TR1	102.6094	94.1382	51.0196
TR2	102.6166	94.5667	50.9350
TR3	102.6727	95.0270	50.9282
TR4	102.7062	95.4929	50.9439
TR5	102.7374	95.9384	50.9594
TR6	102.7769	96.3743	50.9783
TR7	102.8138	96.8199	50.9989
TR8	102.8483	97.2672	51.0185
TR9	102.8788	97.7109	51.0286
TR10	102.9236	98.1636	51.0470
TR11	102.9541	98.5989	51.0563
TR12	103.0042	99.0651	51.0853
TR13	103.0198	99.5064	51.1301
TR14	103.0337	99.9478	51.1240
TR15	103.0800	100.3940	51.1308
TR16	103.1161	100.8485	51.1095
TR17	103.1585	101.2939	51.1173

Name	X _L	Y _L	Height
TFR5	103.7435	95.8498	51.0459
TFR6	103.7680	96.2732	51.0536
TFR7	103.8040	96.7836	51.0767
TFR8	103.8298	97.1612	51.0831
TFR9	103.8525	97.6192	51.0944
TFR10	103.8822	98.0774	51.1058
TFR11	103.9285	98.5125	51.1117
TFR12	103.9754	98.9569	51.1247

Table 3 Control points

4.3.3 Additional points

The following list of co-ordinates contains additional surveyed points on site.

Name	X _L	Y _L	Height
Leaky nail 1	101.336	96.0195	51.175
1993 nail	100.763	99.633	51.260
Leakey nail 2	104.347	95.788	51.256
W2	97.952	102.895	50.830
N	111.275	125.778	50.787
S	98.696	86.945	51.720
D	65.965	109.508	52.452
B	125.384	147.615	52.266

Table 4 Control points

4.4 Photogrammetry Field Procedures

4.4.1 Photogrammetric data acquisition for the trackway

The photogrammetric survey of the southern trackway was done on 15 base lines separated by intervals of 45 cm, the lines corresponded to the photogrammetric control markers temporarily attached to the track surface. The survey was designed to provide complete dual stereo cover for the conventional and digital cameras. Overlap designs are shown in figures B and C. One complete stereo over is achieved with the even numbered images (pair AL2-AR2, AL4-AR4 etc.) and a second one with the uneven numbered pairs (figures D and E).

For each set of images the camera support bar was positioned over the track to allow for the camera to be centered over the relevant line of control markers, starting with the second base line. The support bar was levelled to provide a horizontal reference at an average height of 1.3m and 1.6 m for the UMK and DCS cameras respectively. Camera positions were marked on the support bar to give a 30 cm image base separation, centered over the relevant control markers. (The original intention to keep the camera at consistent elevations for all images [1.3 m for the UMK and 1.6 m for the DCS] could not be realized due to the lateral slope of the track. The overlap diagrams [figures B and C] are given for typical camera elevations of 1.3 m.) Images were then captured as follows:

4.4.1.1 Photography with the UMK Metric Camera

Black and white glass plates (TMAX, 100 ASA) were exposed at the appropriate aperture and shutter speed, as determined before each exposure. This was typically f11 and 1/60 sec. The permanently fixed 100 mm lens of the camera was focused to the set distance of 1.4 m. Images were captured 15 cm to the left and right of, as well as directly above, the mid point of the control marker pair. For the hipparion track section (control point lines 2 to 12) only left and right images were captured.

The glass plates were later developed in the "dark room" tent at camp. It was only noticed in Cape Town that glass plates AR13 and AR16 had been inadvertently mounted in the plate holders with the emulsion facing down, resulting in slightly blurred images. These images were not used for photogrammetric processing. As the entire trackway was covered twice, the neighbouring images were used for the photogrammetric mapping.

The following image numbering convention was adopted. Images of the main track are labeled with an A followed by letter L, no letter and R for left, center and right image respectively. (Right and left are again taken in track direction, i.e. left is west and right is east). The same convention is adopted for the eastern (hipparion) track section, but B is used instead of A.

The images are designed to contain 6 control points each. It is for this reason that the first image set (AL2, A2, AR2) begins in control point row two and not in row one. Each of the images AL2, A2 and AR2 then contain the six control points TL1, TR1, TL2, TR2, TL3 and TR3 etc.

Control point	Control point	Control point	Image	Image	Image	Image	Image
TL1	TR1						
TL2	TR2		AL2	A2	AR2		
TL3	TR3		AL3	A3	AR3		
TL4	TR4		AL4	A4	AR4		
TL5	TR5	TFR5	AL5	A5	AR5	BL5	BR5
TL6	TR6	TFR6	AL6	A6	AR6	BL6	BR6
TL7	TR7	TFR7	AL7	A7	AR7	BL7	BR7
TL8	TR8	TFR8	AL8	A8	AR8	BL8	BR8
TL9	TR9	TFR9	AL9	A9	AR9	BL9	BR9
TL10	TR10	TFR10	AL10	A10	AR10	BL10	BR10
TL11	TR11	TFR11	AL11	A11	AR11	BL11	BR11
TL12	TR12	TFR12	AL12	A12	AR12	BL12	BR12
TL13	TR13		AL13	A13	(AR13)		
TL14	TR14		AL14	A14	AR14		
TL15	TR15		AL15	A15	AR15		
TL16	TR16		AL16	A16	(AR16)		
TL17	TR17						

Table 5 Table of UMK images with associated control points

UMK images	row A	15 * 3	45 (43)
	row B	8 * 2	16
	Total		61 (59)

Table 6 Number of UMK images

Note: Images AR13 and AR16 are out of focus and cannot be used, as the plates were incorrectly mounted in the camera.

4.4.1.2 Photography with the DCS 420 Digital Camera

Black and white images were captured at an aperture and exposure of typically f11 and 1/250 s. A 14 mm lens was used at a fixed (taped down) and pre-calibrated focal length. As with the UMK photography, images were captured 15cm to the left and right of, as well as directly above the mid point of the control marker pair. For the hipparion imprints a full set of images, left, center and right was captured.

Oblique images were taken over the full width of the trackway with the camera handheld. All DCS images were downloaded onto the hard-disk of a notebook computer at camp.

4.4.1.3 Photography with the Hasselblad Camera

Tom Moon used color film to capture a stereo-pair of images over the hominid track imprints only (see also Part VII.) Two images were exposed in the left and two in the right positions over the middle of the relevant control marker set. Typical aperture and exposure readings were f11 and 1/60 s. An 80 mm lens was used at a set (taped down) focal length which was later calibrated by photographing the footprint control frame from multiple perspectives. Calibration parameters were determined later in a bundle adjustment calculation.

Fifteen stereo pairs of Hasselblad images were taken of the A track. All photographs were duplicated. The total number of Hasselblad images is thus $15 * 4 = 60$. The rolls of film were developed by Tom Moon in the United States.

Control	Control	Control	Image	Image	Image	Image	Image	Image	Oblique
TL1	TR1								
TL2	TR2		AL2	A2	AR2				4
TL3	TR3		AL3	A3	AR3				4
TL4	TR4		AL4	A4	AR4				7
TL5	TR5	TFR5	AL5	A5	AR5	BL5	B5	BR5	7
TL6	TR6	TFR6	AL6	A6	AR6	BL6	B6	BR6	6
TL7	TR7	TFR7	AL7	A7	AR7	BL7	B7	BR7	7
TL8	TR8	TFR8	AL8	A8	AR8	BL8	B8	BR8	5
TL9	TR9	TFR9	AL9	A9	AR9	BL9	B9	BR9	5
TL10	TR10	TFR10	AL10	A10	AR10	BL10	B10	BR10	6
TL11	TR11	TFR11	AL11	A11	AR11	BL11	B11	BR11	6
TL12	TR12	TFR12	AL12	A12	AR12	BL12	B12	BR12	7
TL13	TR13		AL13	A13	AR13				5
TL14	TR14		AL14	A14	AR14				5
TL15	TR15		AL15	A15	AR15				6
TL16	TR16		AL16	A16	AR16				
TL17	TR17								

Table 7 DCS images and associated control points

DCS Images	row A	15 * 3	45
	row B	8 * 3	24
	obliques		82
	Total		151

Table 8 Number of DCS images

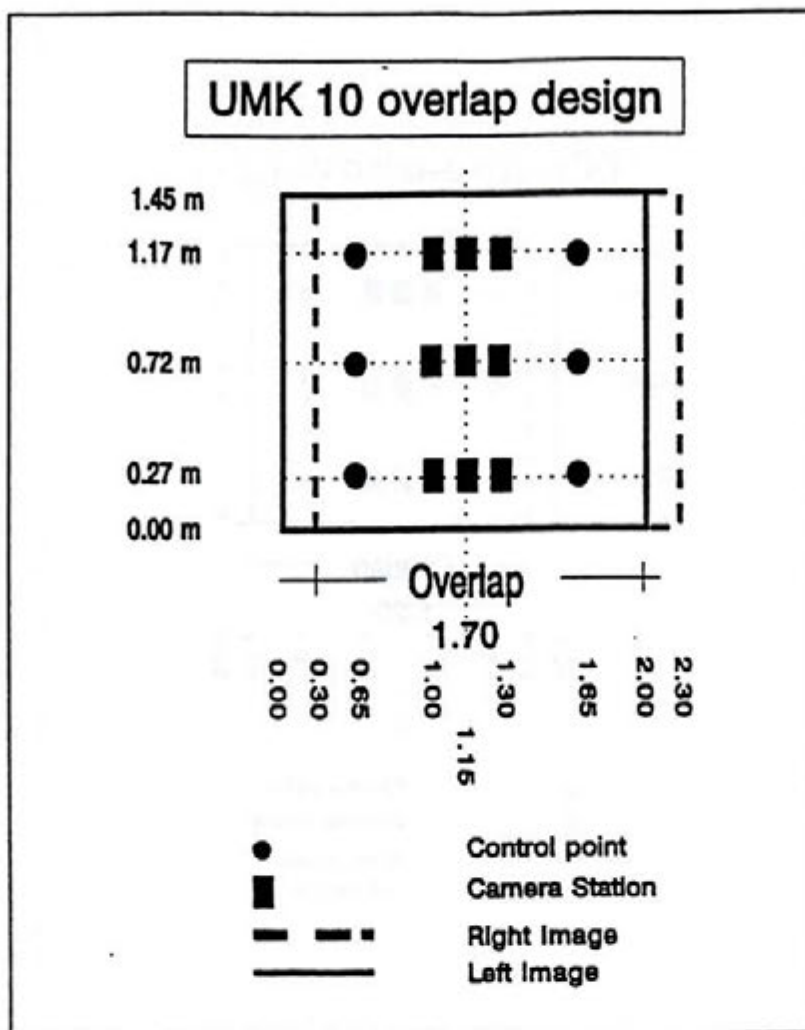

Figure B UMK 10 overlap for track

nominal focal length	100 mm
usable image area	155 mm by 110 mm
base line	0.30 m
height above surface	1.30 m
image scale	1 : 13
ground cover	2.00 m by 1.45 m
lateral overlap	1.75 m (85%) by 1.45 m
along track overlap	0.85 m (58%) for sequential set ups 0.40 m (27%) for alternating set ups

Table 9 Photogrammetric design of UMK trackway photography.

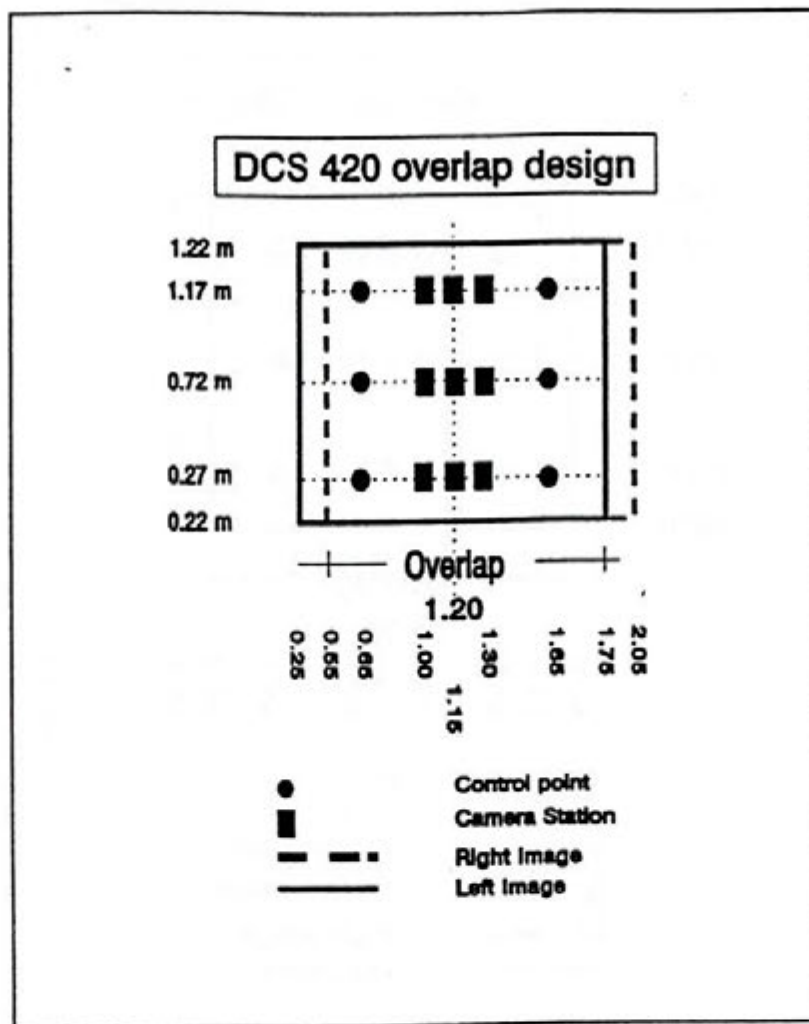

Figure C DCS 420 overlap for track at 1.6 m above ground.

nominal focal length	14.5 m m	
usable image area	13.5 mm by 9 mm	
base line	0.30 m	
height above surface	1.60 m	1.80 m
image scale	1 : 110	1 : 125
ground cover	1.50 m by 1.00 m	1.70 by 1.10
lateral overlap	1.20 m (80%) by 1.00 m	1.40 (93%) by 1.10
along track overlap	0.85 m (58%) for sequential set ups 0.40 m (27%) for alternating set ups	0.65 (60%) for sequential s.u. 0.10 (10%) for alternate s.u.

Table 10 Photogrammetric design of DCS 420 trackway photography.

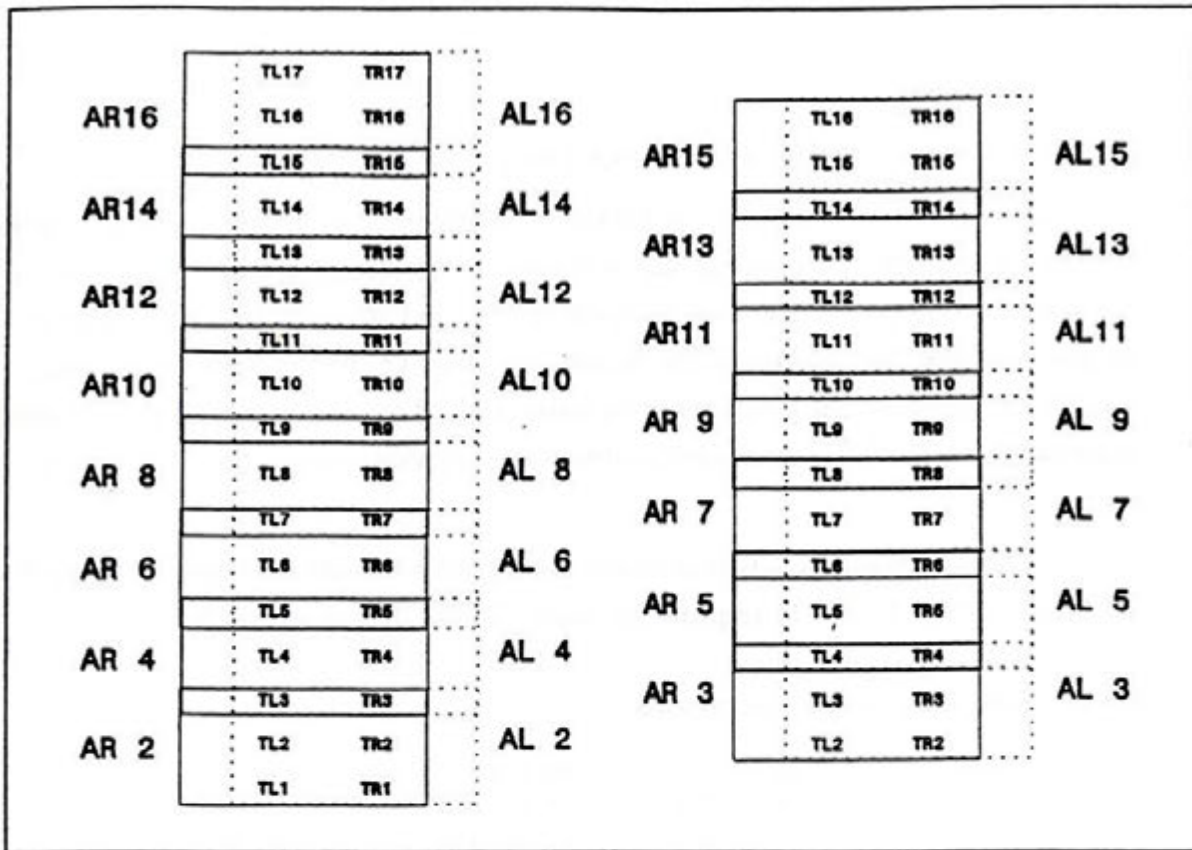

Figure D Dual stereo coverage of track with UMK photography (AR13 and AR16 not usable)

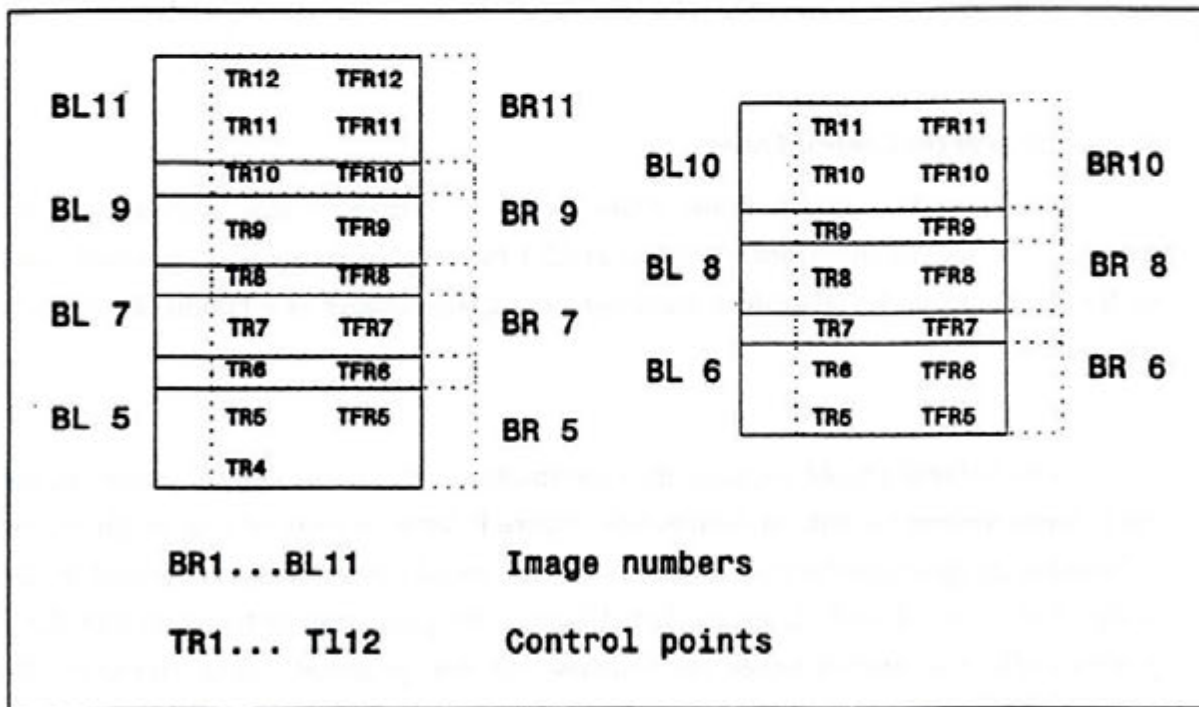

Figure E Dual stereo coverage of east track section with UMK

4.4.2 Photogrammetric data acquisition for the individual footprints

Each hominid footprint was surveyed individually to obtain a more detailed map of the imprint. This required the footprints to be photographed within a control frame, which was placed over each footprint in turn and surveyed immediately prior to the photography. The survey of the frame, or rather of three points on it, made it possible to determine the position of the frame and all its control points in the Laetoli coordinate system. This is necessary to obtain the footprint coordinates in relation to the track.

A total of 29 imprints was recorded photogrammetrically: 15 imprints in track G1: G1-25 -G1-39; 14 imprints in track G2/3: G2/3-18 -G2/3-31

The recording dates and sequence were:

13-8-95	14-8-95	16-8-95	
1 G2/3-29	8 G2/3-26	15 G1-33	22 G2/3-21
2 G2/3-30	9 G1-35	16 G2/3-20	23 G1-28
3 G1 -39	10 G2/3-25	17 G1 -27	24 G1-29
4 G2/3-28	11 G1-34	18 G2/3-19	25 G2/3-22
5 G1-37	12 G2/3-31	19 G1 -26	26 G1-30
6 G2/3-27	13 G1-38	20 G2/3-18	27 G1-31
7 G1 -36	14 G2/3-24	21 G1 -25	28 G1-32
			29 G2/3-23

4.4.3 Survey of the Control Frame

The portable control point frame with 70 retro-reflective targets and the associated transformations are explained in 6.2.1 below. The frame was surveyed prior to the fieldwork under laboratory conditions using nine images in a bundle adjustment calculation.

The following table contains the coordinates of the frame control points in the local frame system in units of millimeters. Figure F shows a copy of one of the frame calibration images with the point numbers and the coordinate axes superimposed on the image. Points 30, 31 and 32 are not listed here as the photogrammetric survey of these points yielded accuracies below the required 0.3 mm precision value. However, the remaining 67 points are more than sufficient to provide a reliable control field.

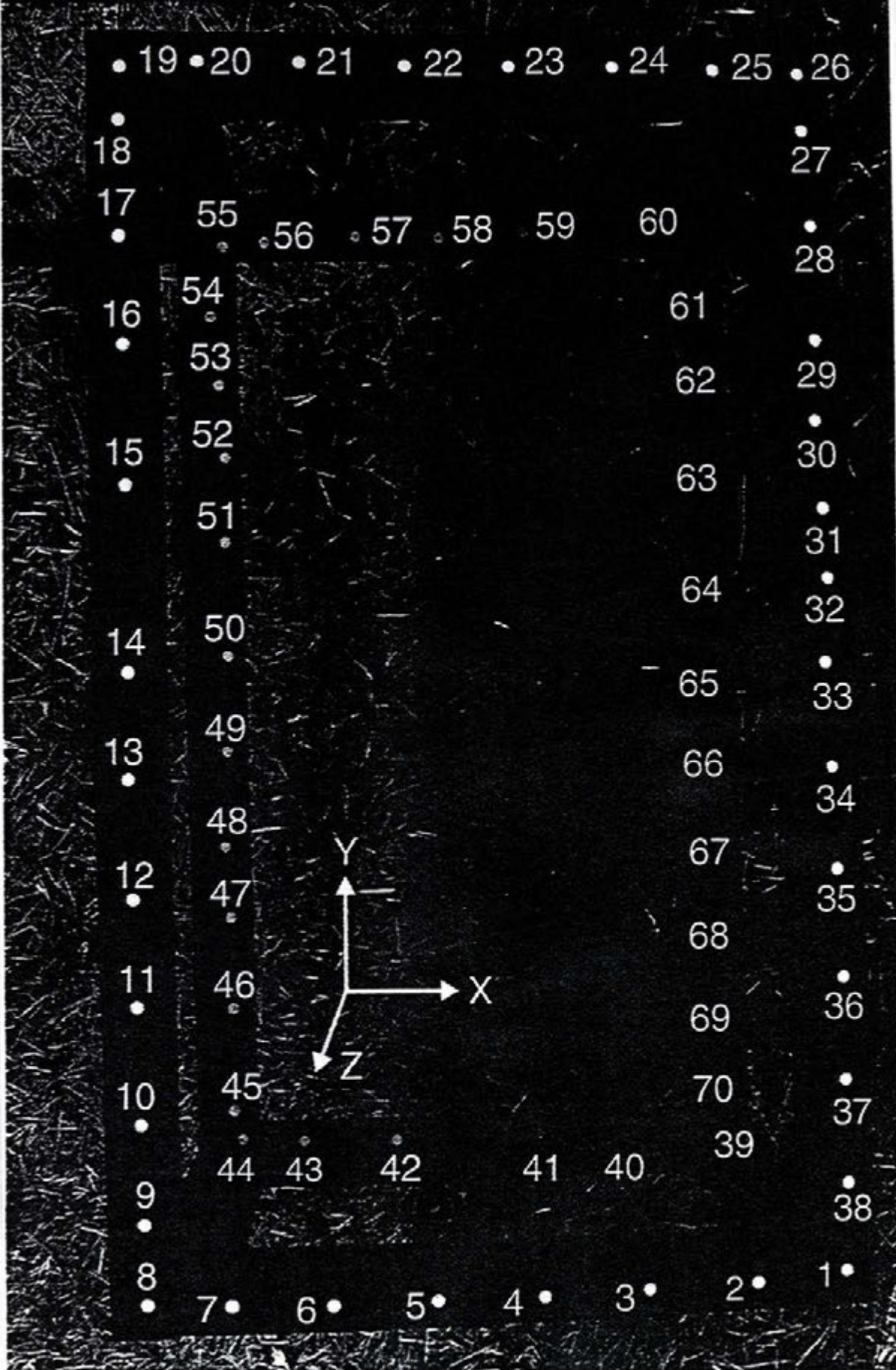

Figure F Camera calibration and control point frame

CONTROL FRAME COORDINATES

Point no.	x [mm]	y [mm]	z [mm]
1	433.65	101.90	1029.50
2	390.17	99.51	1032.09
3	338.56	100.13	1033.43
4	288.37	99.67	1034.59
5	238.20	100.61	1035.66
6	189.87	100.41	1036.61
7	143.31	101.84	1037.42
8	105.76	103.46	1038.56
9	105.62	140.37	1038.68
10	105.61	186.42	1039.10
11	105.38	239.51	1039.32
12	104.88	288.00	1039.53
13	104.36	341.58	1039.97
14	105.33	389.91	1040.25
15	105.70	474.74	1040.36
16	105.47	539.51	1040.42
17	104.02	589.79	1040.55
18	104.22	645.15	1040.26
19	104.97	670.85	1039.85
20	140.79	673.10	1038.04
21	188.82	672.46	1036.47
22	239.07	670.54	1034.77
23	289.15	670.37	1032.81
24	340.52	669.89	1030.92
25	390.77	669.04	1028.95
26	433.01	668.10	1027.57
27	433.34	639.57	1027.97
28	434.96	592.46	1028.22
29	434.10	537.50	1028.49

Point no.	x (mm)	y (mm)	z (mm)
33	431.69	386.01	1029.12
34	433.17	337.22	1029.15
35	433.98	290.07	1029.26
36	435.31	239.74	1029.27
37	435.06	192.25	1029.44
38	435.37	143.42	1029.58
39	395.03	131.07	883.72
40	350.07	127.84	880.31
41	301.53	132.53	881.60
42	219.82	132.91	883.70
43	167.87	134.53	885.26
44	133.67	137.79	890.23
45	129.27	153.79	889.55
46	130.48	210.04	889.70
47	130.74	260.01	889.84
48	128.82	299.14	889.84
49	131.12	351.47	889.96
50	132.71	404.15	889.89
51	132.69	467.46	889.92
52	133.59	514.81	889.78
53	130.93	555.68	890.00
54	126.94	594.51	890.15
55	134.29	634.57	889.88
56	157.74	637.50	886.21
57	210.27	640.36	884.18
58	258.88	639.23	882.32
59	308.32	641.93	880.66
60	370.57	638.46	878.47
61	397.63	613.86	880.87

Point no.	x (mm)	y (mm)	z (mm)
62	399.29	569.40	881.06
63	398.85	514.56	881.29
64	398.27	451.57	881.63
65	396.64	396.46	881.80
66	398.44	353.18	881.96
67	400.21	303.41	882.26
68	398.51	255.45	882.31
69	401.04	210.07	882.43
70	399.59	171.52	882.57

Table 11 Control frame coordinates

4.4.4 DCS 420 digital camera photography

Six digital black and white images of the footprint were captured with the control frame placed over each of the 29 footprints in turn. The images were taken from the six, approximately symmetrical positions shown in figure G.

Image capture was done with the camera handheld at an elevation of approximately 0.8m. Aperture and exposure values were typically in the order of f8 and 1/125 s. A 14mm lens was used and the camera was pre-calibrated at a fixed (taped down) focal length.

At the end of the photographic sequence for each footprint, a single image of the imprint was captured without the control frame in view. This was intended for use in the production of ortho-images of the imprint in the unlikely event that the frame obscured part of the imprint. Fortunately, this case did not arise and the image with the frame could be used for all imprints.

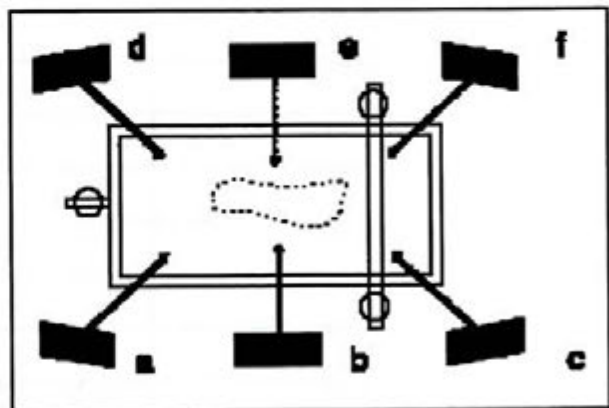

Figure G Image geometry for the DCS photography of individual footprints.

The DCS images were downloaded onto the hard-disk of a notebook computer at camp and backed up on a portable DAT-tape drive. After inspecting the digital images, it became obvious that the resolution of the DCS images (1524 by 1012pixels), although satisfactory for the automatic generation of DEMs, was less acceptable with respect to visualisation and ortho-image generation. The detail of the tuff surface is significantly better imaged on the scanned Hasselblad images and although ortho-images have been generated from the DCS images, it is planned to produce a further set of ortho-images from the scanned Hasselblad images at a later stage.

4.4.5 Hasselblad photography

Color images of each imprint were captured with the control frame placed over the imprint, using a 40 mm lens taped down at a fixed focal length. The camera was supported on a tripod for stability during exposures with typical values of f11 and 1/60s. A camera calibration was carried out by capturing multiple images of the footprint control frame from different perspectives. Calibration values were determined in a later bundle adjustment calculation. Two images were taken from the same position with the camera attached to a tripod and aligned approximately over the left edge of the control frame. This process was repeated with the camera positioned over the right edge. The images were developed by Tom Moon in the USA and proved to be of a very high quality. The total number of images, not counting repetitions in the rare cases of unsatisfactory exposure, are listed in Table 12.

	Track	Footprint
UMK 10	61	-
DCS 420	151	203
Hasselblad	60	116

Table 12 Total number of images

Throughout the UMK, DCS and Hasselblad photography of the footprints utmost care had to be taken to ensure that the frame remained unchanged for the duration of the image capture, as any change in the frame position between images would have rendered the photogrammetric process impossible.

5. PHOTOGRAPHIC PROCESSING

The UMK 10 glass plates were processed under the guidance of Tom Moon in a specially erected 'dark room' tent, consisting of a tent inside a tent. Processing proved very time consuming and the glass plates were developed in four separate sessions of 8, 22, 11 and 24 plates on the August 9, 12, 13 and 15 respectively (See Part VII for detailed description). The quality of the photographic plates proved exceptional with excellent definition on clear high resolution images.

6. PHOTOGRAMMETRIC DATA PROCESSING

The digital and conventional photographic images required a substantial amount of post processing and the work extended from October 1995 to February 1996. In brief, the following processing steps were necessary after completion of the calculation of the control point and frame coordinates. The processes differed for the track and the footprints and are described separately.

6.1 Photogrammetric processing of the trackway images

6.1.1 Mapping from conventional images of the trackway (UMK 10)

- each image pair was mounted in the analytical plotter (Adams Topocart)
- the relative and absolute orientation of the images were restituted by means of the track control points. Points TL6, TL12, TR9 and TR14 were found to be out of position on the UMK images and were not used for the mapping and must also be avoided in any future photogrammetric processing of the images. The intentional over-design of the control point network made it possible to find sufficient stable points on each image for the orientation of all models.
- contour lines and spot heights on 'peaks' and in 'valleys' were captured by the machine operator and stored in ASCII format
- Arc/Info coverages were created from the ASCII files. There were 3 files for each model, one for the contour lines, x.lin, and two for the spotheights, x.xy and x.nz. In the file names for the Arc/Info files, x defines the photogrammetric model and takes even values from 2 to 16 for the hominid track and values B5, B6, B8, B10 and B11 for the hipparion track section

ARC/INFO macros (AMLs) were produced to provide means to generate hard copy of the various covers. As a test, one model was resurveyed in the analytical plotter by capturing a dense grid of spotheights as opposed to following contours. A DEM was then generated from the spotheights and a contour map was produced using the Arc/Info TIN capability. This contour map was compared with the map produced by direct mapping of contours and no significant differences between the two

independent results could be found. A third map of the same area was later generated from the digital images by automated matching methods and again no significant differences could be detected.

6.1.2 Mapping from digital images of the trackway (DCS 420)

Contour maps of the track can also be generated using the automated approach as described in more detail later for the individual footprints. This was done for one image pair only, the image set for the first track section was mapped from the digital images to provide a comparison with the conventional mapping. As the comparison proved satisfactory, there was no need to duplicate the mapping of the track by automatic mapping techniques and the conventional method was accepted as satisfactory.

6.1.3 Generation of Arc/Info files

The ASCII files as derived on the Topocart analytical plotter were converted to Arc/Info coverages by the standard input method. Additional fields were added to the database containing the heights of the contour values as well as spotheights. This was necessary as Arc/Info does not allow feature identifiers to have decimal places. These coverages were then processed into the required output formats, which are dxf, ASCII and E00.

To produce the DEM output files from the contour and spotheight coverages a grid (Arc/Info command TOPOGRID) was produced using both coverages as input. The grid was then converted into a point coverage which in turn was used to create the DEM output files in ASCII and dxf.

6.2 Photogrammetric processing of individual footprint images

6.2.1 Control point determination

In order to map the individual footprints it was necessary to

- surround each imprint with a frame work of control points
- determine the positions of the control points in the Laetoli coordinate system

These conditions were realised by placing the portable control frame over each imprint prior to the photography and by carrying out theodolite observations of horizontal and vertical angles from the reference points to three frame points.

The positions and heights of the three points in the UCT coordinate system were then evaluated by least squares adjustment and transformed to the L/S system. The L/S system coordinates of the three points for the 29 different frame positions are attached (Appendix A). Frame points 1, 19 and 26 provided a good transformation geometry and were used in 28 cases. When photographing G1-38 the frame was inadvertently rotated through 180 degrees and points 1, 8 and 19 were observed, this error was allowed for in the computations.

Once the three control point coordinates were known in both systems, the points were used as common points in a rigid body three-dimensional similarity transformation to transform the remaining 64 frame points from the local system into the L/S system for the 29 frame positions. By this technique a field of 29 sets of 67 (1,943) virtual control points in L/S coordinates was produced around the 29 imprints. It is not practical to list the 1,943 point coordinates in this document, but all information is provided to repeat the transformations and re-establish the 1,943 points by repeating the similarity transformation.

The transformations showed average vector displacement of 0.2 mm between the three local frame coordinate values and the L-coordinates of the same three points (1,19,26) after transformation. This confirms the high precision of the fully independent photogrammetric survey of the frame and the in situ theodolite survey of the same three points in the UCT and Laetoli system.

The table below shows typical average standard deviations as derived from the transformation. These values are a measure of the average difference between the three control points as surveyed in the L/S system and the local frame coordinates after transformation into the L/S system.

	s_x [mm]	s_y [mm]	s_z [mm]	s [mm]
G1-29	0.0925	0.1398	0.0012	0.1676
G1-30	0.1051	0.1058	0.0041	0.1492
G1-31	0.1000	0.1045	0.0011	0.1447
G1-32	0.1566	0.0708	0.0064	0.1720

Table 13 Photogrammetric design of UMK trackway photography

6.2.2 Photogrammetric Digital Image Processing

A set of four Kodak DCS420 digital images out of the six taken for each footprint was used for the photogrammetric determination of the Digital Elevation Models for each footprint. The four images chosen were those captured from exposure stations above the corners of the control frame (a, c, d and f on figure G) as these images provide the best photogrammetric geometry.

6.2.2.1. Conversion of the images

All the TIFF-images downloaded from the PCMCIA of the camera had to be converted to a flat-format, as this is the format required for the in-house software used for the subsequent operations.

6.2.2.2 Exterior Orientation

The first step in the digital photogrammetric process is the determination of the camera positions and orientations in the overall track co-ordinate system, the L/S-system. For this purpose the transformed coordinates of the control frame from their arbitrary co-ordinate system into the trackway system (described above) were required. In a first image processing step, the image positions of the 67 control frame targets were located in each of the four images.

The centers of the targets on all four images were then determined by photogrammetric software and used in a bundle adjustment (both in-house software) to provide the exterior orientation parameters of the four exposure stations. For the bundle adjustments the interior orientation parameters of the camera were held fixed at pre-calibrated values, as determined in an independent camera calibration prior to the footprint photography. Accuracies achieved in the bundle adjustment can be gauged from the residuals to the image coordinates after the adjustment; some typical examples are:

	v_x [mm]	v_y [mm]
G1-31	0.0028	0.0020
G1-32	0.0043	0.0028
G1-33	0.0103	0.0073
G1-34	0.0114	0.0079

Table 14 examples for bundle adjustment accuracies

Average values for the residuals of image coordinates are in the order of 3 micron. These values reflect the agreement between independent data sets of the frame coordinates determined earlier in object space and the image coordinates of the frame points on the DCS images.

6.2.2.3 Interest points and matching.

Points of interest, i.e. points representing texture in the images of the footprints, were then located in one of the four images in a fully automated process. The location of these points involves a high pass filter of the image, which serves to enhance the high frequency components in a fairly uniform image. The high pass filtered image is then convolved with a kernel designed to extract gradient changes above a specified threshold level. Once the interest points have been determined by convolution in the x- and y- directions, they are combined (vectorized), thinned out (Förstner thinning operator) and located to subpixel accuracy with the method of preservation of the moment.

Points corresponding to the extracted points of interest in the remaining three images were then extracted. The coordinates are required to obtain the object space (xyz) coordinates for the points of interest in a subsequent space intersection program. The identification and the determination of such conjugate point positions in terms of image coordinates is referred to as image matching.

The image matching process employed for the footprints relies on a least squares solution with geometric constraints, where matching image points are determined

together with the object space coordinates of the corresponding object points. All software employed for interest point extraction, image matching and bundle adjustment was developed in-house. The results of the image matching process are lists of 3D-xyz co-ordinates in the Laetoli system representing a densely spaced distribution of points which model the footprint being mapped.

The number of points per footprint varied from about 3000 for the smaller of the G1 imprints to more than 13000 for the biggest of the G2/3 imprints. The bundle adjustment result showed image coordinate precisions of 2 micrometers, again confirming the overall high accuracies of the integrated survey operations.

6.2.2.4 Selection of the matching area and computer runs

In the first image an area surrounding the footprint had to be selected for further processing. This area is defined by a polygon and all points of interest falling into this defined polygon are chosen to be matched. Matching was the most time consuming component of the entire photogrammetric process. The table below lists the number of points found on each imprint, the type of computer used and the processing time.

The computers used for the matching routines were

486	: 33 MHz, 16 RAM
486	:100 MHz, 16 RAM
486	:100 MHz, 16 RAM notebook
Pentium	: 90 MHz, 32 RAM
Pentium	:100 MHz, 16 RAM
HP Unix Machine	

Processing times depend on the type of system used, the load on the system and the RAM available. Times given here can therefore merely be a rough guide. The number of matched points was largely a function of the size of the selected area, which had to be chosen larger for a bigger footprint or for one not clearly defined in its extend. Thus, the number of match points are no measure of detail or accuracy. The ratio of successful matches in relation to the points of interest entered into each matching routine was between 89% and 95%, an indication of very good matching result.

After the matching each footprint was checked with a program which overlays the first image of each set with a point map showing all matched points. This made it possible to check that there are no areas with poor point density for the selected imprint or its proximity.

	number of points	computer used	proc. time
G1-25	4508	486	8h
G1-26	7910	486	5h
G1-27	2771	486	4h
G1-28	9163	HP Unix	5h
G1-29	11006	486	19h
G1-30	6253	HP Unix	3h
G1-31	3421	HP Unix	7h
G1-32	5014	486	7h
G1-33	8153	486	14h
G1-34	4333	Pentium	6h
G1-35	5678	Pentium	7h
G1-36	4362	HP Unix	18h
G1-37	3858	486	17h
G1-38	4383	486	8h
G1-39	10658	486	23h
G23-18	13525	486	26h
G23-19	9186	486	19h
G23-20	9586	HP Unix	19h
G23-21	9165	HP Unix	19h
G23-22	7071	HP Unix	12h
G23-23	10524	HP Unix	14h
G23-24	11136	Pentium	16h
G23-25	8996	Pentium	13h
G23-26	10995	Pentium	14h
G23-27	8011	Pentium	12h
G23-28	12552	Pentium	23h
G23-29	8270	Pentium	14h
G23-30	12541	Pentium	8h
G23-31	7625	Pentium	8h
		Total	386h

Table 15 Matching results and processing time

6.2.2.5 Result of the photogrammetric process

The final result of the photogrammetric process is a file of object space coordinates X_L , Y_L , Z_L (height) in the L/S-System. This file, or rather the point cloud it contains, provides the basis for the DEM and subsequent products. Accuracies of generated point coordinates were derived in the least squares bundle adjustment and all points showed position and height accuracies of better than 0.5 mm and typically 0.2-0.3 mm.

6.2.3 DEM - Generation

In general it must be noted that any surface mapping or contouring, be it automated or manual, requires interpretation of the areas between recorded points. This interpretation must lead to inaccuracies and perfect presentation of the object is not possible. The various software packages available for the automated contour/surface generation rely on a range of interpolation algorithms for the 'inter-point' areas and depending on the operator's choice the result can differ notably.

Tests for the footprint modelling showed that two of the available packages, Arc/Info TIN and surfer, appeared designed for smoother terrain, while the finite element model of the HIFI software proved more sensitive to small changes in the surface. It was therefore decided to use HIFI for the surface modelling. Available was HIFI version 3.2, Height Interpolation by Finite Elements, a software package lent to the University Cape Town by the PHOTOGRAMMETRY GmbH Munich.

HIFI is a general software package for the generation of DEM from three-dimensional points and lines and for the derivation of DEM-based information. A central part of the package is a DEM data base, which is used to store and manage the input data as well as the DEM generated from that data. A variety of secondary products such as profiles, contour lines, perspective views, difference models, volume, and slope/aspect maps can be derived from the DEM. HIFI is part of the digital photogrammetry station ZEISS/PHODIS.

For the generation and representation of the DEM and the derivation of numerical and graphical output, a raster DEM was generated by interpolating

from the randomly distributed interest points to the grid intersections of a rectangular raster of raster cells, square in planimetry. The heights of the raster points were interpolated from the height values of the input data using a finite elements model. For every individual footprint one to three DEM's were calculated and afterwards contour maps with a contour space of 1.0mm and perspective views were produced. (Time per DEM: 60 min., total processing time: 29 h)

6.2.4 Generation of Arc/Info files.

The two dxf-files generated on HIFI, the contour file and the grided DEM, were imported to Arc/Info, where they were used to create the Arc /Info coverages. The coverages are listed in section 8. below. Additional fields were added to conform to the track coordinate files. The coverages were then exported in E00 format.

7. ORTHO-IMAGE GENERATION

7.1 Footprint ortho-images

Four ortho-images were produced for every footprint, two at a scale of 1:0.22725 (i.e. 1 pixel on the screen is equal to 0.22725 mm on the ground). The other two are at a scale of 1: 0.5. All four ortho-images cover exactly the same area on the ground. The ortho-images at a scale of 1:0.5 are at a suitable size for viewing on a computer screen. Typical image dimensions for a footprint at this scale are 800 x 500 pixels. However, these image dimensions are not suitable for printing purposes. A laser printer typically prints at a density of between 300 and 600 dots per inch (dpi). If an ortho-image of 800x500 pixels is printed at a density of 600dpi the image on the paper will be 34 mm x 21 mm. This is too small to be of practical use and therefore the additional set of ortho-images at a scale of 1:0.22725 was produced for printing purposes.

For every footprint, two ortho-images were produced for each of the scales. Although the two ortho-images should be almost identical, they were in fact produced from different original images. This has a number of advantages:

- i Some features that are obscured in one image might be visible in another.
- ii One image might have better lighting conditions than the other.
- iii Each ortho-image can be checked against its 'twin' for discrepancies.

7.2 The software concept

The ortho-images were produced using in-house software. The software concept is:

- i The initial dimensions of the ortho-image are determined by scaling the dimensions of the footprint DEM. This means that the ortho-image covers exactly the same area on the ground as the DEM.
- ii The xy center of the ortho-image is determined by taking the center of the DEM coverage.
- iii The ortho-image is then produced by finding the sub pixel in the original image that corresponds to a pixel in the ortho-image. This is done for every pixel in the ortho-image based on the DEM and the cameras interior and exterior orientation elements. This process is termed rectification. The external calibration of the image is obtained from the bundle adjustment described in 6 above.

The final product is an image that is true to scale, i.e. the effects of perspective are removed and true distances can be measured directly off the ortho-image. This image is saved to disk in a raw format and then converted to a TIFF graphics file format.

7.3 Interpolation techniques for the rectification

Rectification involves resampling a subpixel. Resampling requires the determination of the greyvalue of a pixel which was shifted in the rectification process. As the rectified pixel will typically not coincide with the center of a pixel, interpolation is required. A number of interpolation techniques exist to do this. Due to the relatively low resolution (when compared with a film based camera) of the digital camera the interpolation technique used plays an important role in the quality of the final ortho-image.

The interpolation techniques tested were:

- i Nearest neighbour - this produced 'blocky' and inaccurate results.
- ii Bilinear - the results of this technique did not have the pixel (block) characteristic of the nearest neighbour method, but at the larger scale pixel blocks became visible at the steep edges of the imprints.
- iii Bicubic splines - this method produced a smooth and accurate ortho-image, even at large scales.

Therefore the bicubic interpolation was employed to resample the image.

8. DIGITAL IMAGE QUALITY

The resolution (1524 by 1012 pixels over a chip area of 13.8 by 9.2 mm) proved, as mentioned earlier satisfactory for the automated DEM generation but was not acceptable with respect to definition of detail. An attempt was made to improve the visual image quality by image processing techniques and in addition to the original 354 images, two sets of the enhanced images were produced using "Image Magick" software. The first enhancement consisted of a normalisation followed by a sharpening operation with a 90% sharpening factor. The second enhancement was done by equalising the image, this enhancement emphasised edges, roots and cracks in the surface. However, none of the enhanced images were used for digital photogrammetry, as geometric distortion of the image detail might have occurred as result of the image processing operation.

9. RESULTS

The end products of the photogrammetric survey are the track and footprint DEM generated from the UMK and DCS images. In the interest of maximum flexibility the data were produced in multi-coverages, which can be combined as required, and in different output formats. The output formats are ASCII, dxf and E00. These file formats were chosen to provide maximum flexibility. The ASCII formats can be imported in most CAD, visualisation and mapping software, but data in this form will require processing before they can be displayed in any chosen form. The dxf- format does already represent a final displayable format (contours), but can only be viewed in specific software packages, for example in AutoCad. E00 is an export format specific to Arc/Info, it was chosen to provide immediate readability in Arc/Info software.

Including the image files, some 600 files were generated for the track and 930 for the footprints. The following table lists all files generated. The value in the first column gives the number of files of each type.

LIST OF ALL GENERATED FILES

Trackway files	File format	Trackway section	Description
8	dxf	Hominid	contours
8	dxf	Hominid	spotheights
5	dxf	Hipparion	contours
5	dxf	Hipparion	spotheights
8	E00	Hominid	contours
8	E00	Hominid	spotheights
5	E00	Hipparion	contours
5	E00	Hipparion	spotheights
8	ASCII	Hominid	DEM-grid
5	ASCII	Hipparion	DEM-grid
8	dxf	Hominid	DEM-grid
5	dxf	Hipparion	DEM-grid
8	dxf	Hominid	combined contours-spotheights
5	dxf	Hipparion	combined contours-spotheights
8	E00		trench outlines
1	E00		grid -intersections
1	E00		control points
8	ASCII		trench outlines
1	ASCII		grid-intersections
1	ASCII		key to trenches
1	ASCII		control points
25	AML		plotting macros
13	TIFF		UMK ortho images
Images			
151		DCS	original
151		DCS	normalised
151		DCS	equalised
12		UMK	scanned images

Individual imprints	File format	Trackway section	Description
29	dxf		contours
29	dxf		DEM-grid
29	E00		contours
29	E00		contours
29	E00		DEM-grid
29	ASCII		random point cloud
29	ASCII		DEM-grid
29	dxf		random point cloud
Images			
203	TIFF	DCS	original image
203	TIFF	DCS	normalised
203	TIFF	DCS	equalised
Ortho-images			
29	TIFF		small scale
29	TIFF		small scale
29	TIFF		large scale
29	TIFF		large scale

Table 16 Generated files

In the table above terms used are:

- contours line data for the representation of contours, labeled with contour values.
- spotheights list of individual points indicating points which cannot be represented by contours, such as peaks or depressions.
- DEM grid elevations of the track surface at a regular grid interval as derived from the grid interpolation of the contour lines (UMK plots on Topocard) or from the random points generated by the automatic matching program (DCS images).
- hominid term used here to describe the principal track area containing

the hominid trackway .

hipparion describes the area to the east of the hominid track from the hipparion tracks in the south to the carnivore track in the north.

10. CONCLUSIONS

It can be concluded that both the field work and the subsequent data processing were highly successful, with the original objectives achieved and with some unplanned additions to the project. A total of 29 imprints was recorded photogrammetrically, individually and with the surrounding track area and in digital and analog form. The recorded imprints are 14 footprints of track G1, G1-25 to G1-39, and 15 imprints in track G2/3, G2/3-18 to G2/3-31. The UMK analog images and the Hasselblad images of the track and footprints respectively proved to be of a very high quality, while the visual appearance of the digital images suffered somewhat from the limited resolution of the digital camera. Nevertheless, the digital images proved highly successful for the automated DEM generation in view of the high rate of precise DEM information extracted from the DCS images.

The data processing stage proved considerably more complex and time consuming than anticipated. The sheer volume of the data in more than 1500 files with more than a quarter of a million DEM points resulted in extreme demands in the areas of data management, data storage and computing power. The UCT team required a total of approximately one month preparation, two weeks field work and four month of post-processing to complete the data set described in this report.

Hardcopy of the data was only produced for, but it is highly recommended that hardcopy of all plots be generated by Arc/Info software (macros are provided) in the interest of information conservation. Due to time pressure the capabilities of CAD system with respect to the presentation of the data was not explored, this will be done in the near future.

Accuracies achieved for all point positions were better than 0.5 mm in position and height. The overdesign of the image cover with analog and digital images was justified and should be maintained for the survey of the second half of

the track. It is however doubtful if the large number of file duplications in ASCII, dxf and E00 formats is necessary, as the more powerful software packages are capable of reading other products formats. However, the ASCII format should be maintained as this is the format most likely to survive as the most basic data form for the future, while other formats may be replaced by new developments. With a view to long-term readability in a rapidly changing computer environment it appears also doubtful if files should be compressed in any form. Compression algorithms are likely to change and compression methods now used may no longer be available in the future.

Acknowledgements

I gratefully acknowledge the support and advise of the members of the Getty field team, especially Martha Demas, Angelyn Bass, Gaetano Palumbo and Tom Moon, whose patient assistance with the tedious photogrammetric field process proved invaluable.

Special thanks must go to the UCT team of dedicated technical staff, Ph.D. and MSc students: Susan Binedell, Ulrike Brüssler, Julian Smit and Henty Waker as well as the department's Administrative Assistant Val Atkinson and my colleague Scott Mason. The original time planned for the project more than tripled due to a variety of unforeseeable problems and at occasions the data collected appeared simply overwhelming. In spite of this all team members remained committed to the project and its objectives and spent numerous hours of extra time on the project.

I also wish to thank R.C. 'Dick' Oelofse of the Anglo American Organisation, Johannesburg, for the loan of equipment and the scanning of 12 UMK images on a high quality scanner. Furthermore, I gratefully acknowledge the support of PHOTOGRAMMTRIE GmbH München, who made the software available at a greatly reduce rate.



Positions of frame points 1, 19 and 26 for the determination of the 29 control frame positions

The table below lists the positions of points 1, 19 and 26 as required for the photogrammetry of the 29 footprints. These positions are required for the transformation of the control frame into the Laetoli system in each of the 29 cases. When photographing G1-38 the frame was inadvertently reversed and points 8,1 and 19 were observed instead of 26, 19, 1.

	point num.	x	y	height
G2/3-29	26	102.6413	95.5724	51.1832
	19	102.3149	95.5530	51.1556
	1	102.6803	95.0080	51.1758
G2/3-30	26	102.5586	95.0356	51.1686
	19	102.2312	95.0441	51.1480
	1	102.5495	94.4700	51.1571
G1-39	26	102.2064	95.2273	51.1538
	19	101.8918	95.1342	51.1507
	1	102.3719	94.6864	51.1372
G2/3-28	26	102.5043	95.9770	51.1918
	19	102.1775	95.9893	51.1653
	1	102.4890	95.4113	51.1778
G1-37	26	102.1916	96.0224	51.1763
	19	101.8651	95.9922	51.1621
	1	102.2488	95.4593	51.1688
G2/3-27	26	102.5792	96.4546	51.2156
	19	102.2514	96.4613	51.2012
	1	102.5729	95.8886	51.2047
G1-36	26	102.3469	96.4128	51.2008
	19	102.0202	96.4395	51.1833
	1	102.3056	95.8482	51.1947
G2/3-26	26	102.5232	96.8962	51.2363
	19	102.1972	96.9261	51.2128
	1	102.4770	96.3319	51.2251

		x	y	height
G1-35	26	102.1739	96.8833	51.2103
	19	101.8526	96.8181	51.1919
	1	102.2916	96.3298	51.1926
G2/3-25	26	102.6977	97.2827	51.2626
	19	102.3702	97.2998	51.2526
	1	102.6732	96.7171	51.2516
G1-34	26	102.4590	97.2732	51.2494
	19	102.1414	97.3534	51.2359
	1	102.3262	96.7229	51.2295
G2/3-31	26	102.7008	94.6474	51.1704
	19	102.3751	94.6368	51.1326
	1	102.7137	94.0888	51.2609
G1-38	8	102.4492	95.4247	51.1579
	1	102.2069	95.5664	51.1604
	19	102.2069	94.9121	51.1476
G2/3-24	26	102.6115	97.7280	51.2621
	19	102.2858	97.7636	51.2418
	1	102.5543	97.1649	51.2687
G1-33	26	102.2865	97.7552	51.2464
	19	101.9613	97.7129	51.2357
	1	102.3648	97.1947	51.2406
G2/3-20	26	102.7230	98.1672	51.2901
	19	102.3964	98.1968	51.2781
	1	102.6773	97.6033	51.2691
G1-27	26	102.4716	98.1426	51.2700
	19	102.1460	98.1780	51.2550
	1	102.4158	97.5793	51.2612
G2/3-19	26	102.6163	98.6644	51.2970
	19	102.2894	98.6399	51.2879
	1	102.6641	98.1007	51.2804
G1-26	26	102.3114	98.5156	51.2764
	19	101.9839	98.5041	51.2662
	1	102.3375	97.9506	51.2601

		x	y	height
G2/3-18	26	102.7680	99.0175	51.3142
	19	102.4401	99.0093	51.3129
	1	102.7877	98.4523	51.2939
G1-25	26	102.6323	98.7405	51.3071
	19	102.3668	98.9323	51.2906
	1	102.3059	98.2783	51.2887
G2/3-21	26	102.6951	99.5287	51.3610
	19	102.3673	99.5332	51.3557
	1	102.6937	98.9640	51.3218
G1-28	26	102.4153	99.3034	51.3276
	19	102.0894	99.3379	51.3133
	1	102.3623	98.7405	51.3030
G1-29	26	102.5420	99.5907	51.3523
	19	102.2148	99.6102	51.3419
	1	102.5141	99.0256	51.3293
G2/3-22	26	102.8961	99.9749	51.3679
	19	102.5680	99.9723	51.3705
	1	102.9056	99.4089	51.3723
G1-30	26	102.4993	99.9127	51.3715
	19	102.1750	99.9607	51.3605
	1	102.4230	99.3531	51.3331
G1-31	26	102.6526	100.2887	51.3590
	19	102.3313	100.3547	51.3596
	1	102.5438	99.7332	51.3529
G1-32	26	102.6500	100.6933	51.3566
	19	102.3413	100.8035	51.3433
	1	102.4641	100.1587	51.3650
G2/3-23	26	102.9262	101.2783	51.3561
	19	102.5983	101.2735	51.3513
	1	102.9397	100.7123	51.3573
G2/3-21	26	102.6951	99.5287	51.3610
	19	102.3673	99.5332	51.3557
	1	102.6937	98.9640	51.3218

PART X. DESCRIPTION AND INVENTORY OF TRACKWAY MOLDS AND CASTS

By M. Demas and A. Bass

INTRODUCTION

The Laetoli trackway at Site G is recorded in molds and casts taken in 1978 and 1979 from the excavated trackway. Inventory and condition surveys of the hominid molds and casts stored in the Laetoli storeroom at the Olduvai camp were undertaken by Jerry Podany, Ron Street and Angelyn Bass during the 1994 and 1995 field seasons.

During the initial inventory in 1994, LP (Laetoli Project) numbers were given to each identified mold and cast in the storeroom. These numbers have been written on the back of the molds and casts for future reference. LP numbers were given only to original 1978-79 molds or casts, and not to new molds and casts made by the Laetoli Project team in 1994 and 1995.

The majority of 1978-79 molds and casts are of single hominid footprints. Six of the molds and casts, however, represent large segments of the trackway containing multiple prints. These have additionally been designated with letters (A-E) for ease of reference (e.g. Section A) (Appendix A). Four of these sections (A-D) belong to the southern trackway, comprising 27 of the 29 hominid prints; only section E, represented by a mold and a cast, belongs to the northern trackway and comprises only 6 hominid prints. Thus of the 70 hominid prints inventoried in 1978-79, 33 are represented on cast segments of the trackway (see Appendix A).

To date, only the large segments have been remolded or cast by the Laetoli Project team. A description of these large segments follows (see Appendix B for location of sections A-D). They are also listed in the inventory (Appendix A) with a brief description of their condition.

SOUTHERN TRACKWAY

SECTION A:

This is the long 4.75 m cast of the southern trackway, comprising 21 hominid prints (from G1-39 and G2/3-31 at the southern end, through G1-25 and G2/3-18 at the northern end). To date, the following molds and casts of Section A exist:

- 1979 POLYESTER CAST

- 1994 MASTER EPOXY CAST FOR ARCHIVE (Stored at the National Museum Dar es Salaam)
- 1994 MASTER SILICONE RUBBER MOLD AND SUPPORT (Damaged 1994/5; repaired 1995)
- 1994-95 PATINATED POLYESTER CAST FOR EXHIBITION (On exhibition at the National Museum, Dar es Salaam)
- 1995 POLYESTER CAST FOR OLDUVAI EXHIBITION (From repaired 1994 mold)
- 1995 POLYESTER CAST FOR FIELD USE (Cut in 4 segments; made from repaired 1994 mold)

The original 1979 mold of Section A has not been found. Sections of molds were tentatively, but incorrectly, attributed to Section A in 1993.

SECTION B:

Section B is a 1979 mold with 10 prints, including the northernmost 4 prints of Section A (G2/3-18, 19 and G1-25, 26) and an additional 6 prints further north (G2/3-21, 22 and G1-28, 29, 30, 31). In its entirety, Section B only exists as a 1979 mold (see Section C below), whose present condition does not allow it to be re-cast.

- 1979 MOLD (SILICONE AND LATEX) AND SUPPORT SHELL

SECTION C:

Section C is a 1979 cast, presumably from the Section B mold. It has been labeled separately because it contains only 8 of the 10 prints recorded on the mold. The southernmost 2 prints (G2/3-19 and G1-26) of Section B were cut away from Section C at some point after it was cast. Since the Section B mold is no longer viable, the Section C cast is the only replicable record of 4 prints (G1-28, 29, 30, 31) of the southern trackway. G2/3-21, 22 exist as individual casts (see Appendix A).

Section C is important because it was taken at an earlier stage in the excavation of these prints; thus the prints on this section differ both from their appearance on the Section A cast and as re-excavated in 1995. While these differences make for an interesting historic document, they limit the usefulness of the Section C cast for either study or exhibition purposes.

- 1979 POLYESTER CAST (FIRST GENERATION)

- 1995 MASTER SILICONE RUBBER MOLD AND SUPPORT
- 1995 POLYESTER CAST FOR ARCHIVE
- 1995 POLYESTER CAST FOR FIELD USE

Taken together, Sections A and C record 27 of the 29 hominid prints in the southern part of the trackway; not recorded are prints G1-32 and G2/3-23 (neither on Section A nor as individual casts).

SECTION D:

This section is a mold of 6 prints (G1-35, 36, 37 and G2/3-26, 27, 28) of the southern trackway that are also recorded on Section A. The condition of this mold (lacking remnants of tuff adhered to the surface) suggests that it was taken from the Section A cast, not the trackway.

- 1979 (OR LATER) SILICONE RUBBER MOLD

NORTHERN TRACKWAY

SECTION E:

This is the only section of the northern trackway and is represented by a mold and cast segment. It records 6 prints (3 G1 prints and 3 G2/3 prints) but since there are no numbers on the cast and the cast does not correspond well with the published schematic plan of prints, the precise identification of these prints will have to await re-excavation of the northern trackway. These 6 prints appear to represent the northernmost 6 prints of the northern trackway—the first of the hominid prints that were identified and excavated in 1978.

- 1978 MASTER LATEX MOLD AND SUPPORT
- 1978 POLYESTER CAST (First generation)

- 1995 MASTER SILICONE RUBBER MOLD AND SUPPORT
- 1995 POLYESTER CAST FOR ARCHIVE
- 1995 POLYESTER CAST FOR FIELD USE AND EXHIBITION

INDIVIDUAL PRINTS

There are 27 individual molds or casts of footprints. Four of the individual G1 prints (17,19,22,24) and two of the G2/3 prints (7,9) are not otherwise represented on large sections.

- 5 SILICONE MOLDS (G1 -22, 24, 26 and G2/3 -7, 9).
- 4 LATEX MOLDS (G1 -1, 2; and G2/3 -1, 2)
- 18 POLYESTER CASTS (Unidentified print, G1 - 1, 17, 19, 22, 24 (2), 25 (2), 26, 33, 34 (2); and G2/3 - 1, 18, 19, 21, 22,)
- 3 PLASTER CASTS (G1-2, 26, and G2/3-2)

At the end of the 1995 field season, all of the molds and casts described above were stored at the Olduvai camp, with the exception of the 1995 epoxy cast and the patinated polyester cast of Section A, which are in the National Museum at Dar es Salaam.



1995 INVENTORY OF LAETOLI FOOTPRINT MOLDS AND CASTS

PRINT #	INVENTORY #	DESCRIPTION	CONDITION	COMMENTS
?	(LP-19)	polyester cast; (27.5x23cm)	fair: brittle	
G1-1	(LP-07)	latex and burlap mold w/ plaster back; (37x25cm)	poor	made in 1978
G1-1	(LP-10)	polyester cast w/ plaster back	good	made in 1978
G1-1	see Section E			
G1-17	(LP-15)	polyester cast; (28x116.5cm)	good	made in 1978
G1-19 or ?17	(LP-30)	polyester cast	good	made in 1978
G1-2	(LP-05)	latex mold w/ plaster back; (41x24cm)	poor	made in 1978
G1-2	(LP-18)	plaster cast; (32.5x22cm)	good	made in 1978
G1-2	see Section E			
G1-22	(LP-29)	silicone rubber and cloth mold w/ plaster back; also polyester cast (26.5x19cm)	good	made in 1978.
G1-24	(LP-16)	polyester cast; (25x17cm)	poor: brittle, fractured, and delaminated	made in 1978
G1-24	(LP-25)	silicone rubber and cloth mold w/ plaster back; also polyester cast (26.5x19cm)	good	made in 1978. "1-24-78" written on plaster back.
G1-25	(LP-08)	polyester and fiberglass cast w/ plaster back; (39x30cm)	good	made in 1978 or 1979
G1-25	(LP-13)	polyester cast w/ plaster back	poor: brittle, fractured, and delaminated	made in 1978 or 1979
G1-25	see Sections A, B & C			
G1-26	(LP-14)	plaster cast; (22x12.5cm)	good	made in 1978 or 1979
G1-26	(LP-26)	silicone rubber and cloth mold w/ plaster back; also polyester cast; (34.5x20cm)	fair: silicone torn in spots; remnants of tuff on the surface	made in 1978. "G1-26-78" written on plaster back
G1-26	see Sections A & B			
G1-27	see Section A			
G1-28	see Sections B & C			
G1-29	see Sections B & C			
G1-3	see Section E			
G1-30	see Sections B & C			
G1-31	see Sections B & C			
G1-33	(LP-09)	polyester cast w/ plaster back; (38x29cm)	good	made in 1979. "G1-33" written on plaster back.
G1-33	see Section A			

1995 INVENTORY OF LAETOLI FOOTPRINT MOLDS AND CASTS

PRINT #	INVENTORY #	DESCRIPTION	CONDITION	COMMENTS
G1-34	(LP-04)	polyester and fiberglass cast w/ plaster back; (42x31.5cm)	good	made in 1979. "G1-34" written on plaster back.
G1-34	(LP-23)	polyester and fiberglass cast; (44.5x29cm)	good	made in 1979
G1-34	see Section A			
G1-35	see Sections A & D			
G1-36	see Sections A & D			
G1-37	see Sections A & D			
G1-38	see Section A			
G1-39	see Section A			
G2/3-1	(LP-12)	latex and burlap mold w/ plaster back; (40x29cm)	poor: cannot cast	made in 1978
G2/3-1	(LP-40)	polyester cast w/ plaster back; (41x28cm)	good	made in 1978
G2/3-1	see Section E			
G2/3-18	(LP-24)	polyester and fiberglass cast	good	made in 1978 or 1979
G2/3-18	see Sections A, B, & C			
G2/3-19	(LP-22)	polyester and fiberglass cast; (49x38cm)	good	made in 1978 or 1979
G2/3-19	see Section A			
G2/3-19	see Section B			
G2/3-2	(LP-03)	latex and burlap mold w/ plaster back; (5.20x3.30cm)	poor: latex and plaster back adhered together	made in 1978
G2/3-2	(LP-17)	plaster cast; (39.5x25cm)	good	made in 1978. "G2-2-'78" written on plaster back
G2/3-2	see Section E			
G2/3-21	(LP-06)	polyester and fiberglass cast; (53x26.5cm)	good	made in 1979. Dark brown color (possibly from excess of catalyst in polyester).
G2/3-21	see Sections B & C			
G2/3-22	(LP-21)	polyester and fiberglass cast	good	made in 1979. Dark brown color (possibly from excess of catalyst in polyester).
G2/3-22	see Sections B & C			
G2/3-24	see Section A			
G2/3-25	see Section A			
G2/3-26	see Sections A & D			
G2/3-27	see Sections A & D			

1995 INVENTORY OF LAETOLI FOOTPRINT MOLDS AND CASTS

PRINT #	INVENTORY #	DESCRIPTION	CONDITION	COMMENTS
G2/3-28	see Sections A & D			
G2/3-29	see Section A			
G2/3-3	see Section E			
G2/3-30	see Section A			
G2/3-31	see Section A			
G2/3-7	(LP-28)	silicone rubber and cloth mold w/ plaster back; (44x22cm)	good	made in 1978
G2/3-9	(LP-27)	silicone rubber and cloth mold w/ plaster back; (36x18cm)	fair: silicone torn in spots	made in 1978
includes: G1-25, G1-26, G1-27, G1-33, G1-34, G1-35, G1-36, G1-37, G1-38, G1-39, G2/3-18, G2/3-19, G2/3-20, G2/3-24, G2/3-25, G2/3-26, G2/3-27, G2/3-28, G2/3-29, G2/3-30, G2/3-31	Section A	polyester and fiberglass cast (4.75mx1.10m)	fair: numerous areas cracked and delaminated; blisters on the surface (from preparation); large areas of unsupported gel coat on the surface.	made in 1979. 5 new molds / casts: silicone rubber mold and support (1994); master epoxy cast (1994); patinated polyester cast (1994) polyester cast (1995); polyester cast cut in four sections (1995)
includes: G1-25, G1-26, G1-28, G1-29, G1-30, G1-31, G2/3-18, G2/3-19, G2/3-21, G2/3-22	Section B (LP-32)	latex and silicone rubber mold (silicone in footprints and latex between footprints) w/ plaster back on pipe support; (2.25mx77cm)	poor: latex and silicone rubber portions separating from each other; latex is brittle and unevenly layered; silicone areas are cracked and deformed (from poor quality silicone); remnants of tuff embedded in surface.	made in 1979. Partial cast labeled Section C.
includes: G1-25, G1-28, G1-29, G1-30, G1-31, G2/3-18, G2/3-21, G2/3-22	Section C (LP-32)	polyester cast; (2.25mx77cm); cast from section B.	good: tuff particles embedded in surface; silicone from a second molding also on surface; white surface gel coat w/ slight pigmentation.	made in 1979 (earlier in the excavation than Section A prints). Cast does not include prints G1-26 and G2/3-19, which are on the mold (Section B). 3 new molds / casts: master silicone rubber mold and support (1995); 2 polyester and fiberglass casts (1995).

1995 INVENTORY OF LAETOLI FOOTPRINT MOLDS AND CASTS

PRINT #	INVENTORY #	DESCRIPTION	CONDITION	COMMENTS
includes: G1-35, G1-36, G1-37, G2/3-26, G2/3- 27, G2/3-28	Section D (LP-31)	silicone rubber mold w/ plaster back and pipe support; (1.63mx60cm)	good	made in 1979 or later. May be a second generation mold (made from the cast) since there are no signs of tuff or rootlets remaining on the surface.
includes: G1-1, G1-2, G1-3, G2/3-1, G2/3-2, G2/3-3	Section E (LP-41)	latex and burlap mold	poor: cannot cast	
includes: G1-1, G1-2, G1-3, G2/3-1, G2/3-2, G2/3-3	Section E (LP-41)	polyester cast (1.23mx70cm)	good: small holes and tears; tuff and rootlets (lifted from molding) embedded on surface; white gel coat	made in 1978. May have been remolded (traces of silicone on the surface). Dark color (may indicate too much catalyst in preparation). 3 new molds / casts: silicone rubber master mold and support (1995) and 2 polyester and fiberglass casts (1995)

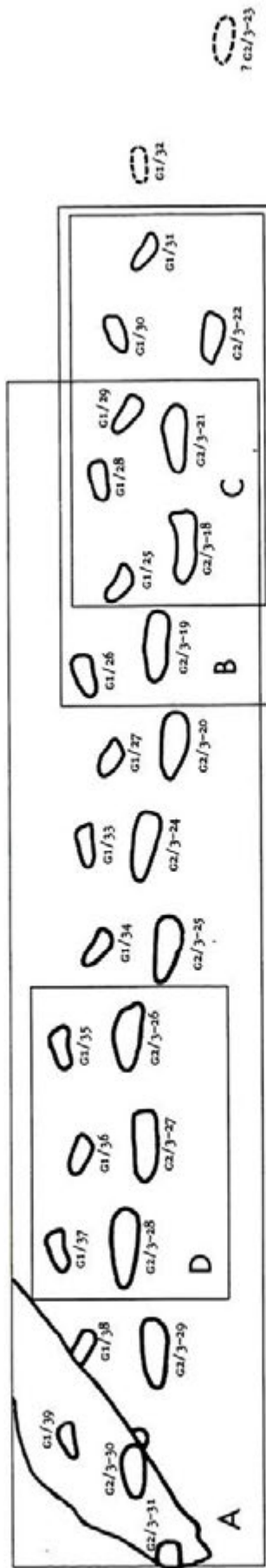

Segments of 1979 molds and casts of the southern portion of the trackway

PART XI. MOLDING AND CASTING ACTIVITIES

By Ron Street

INTRODUCTION

Molding and casting work for the Laetoli Project took place in Dar es Salaam and at the Endulen field camp from July 3-23. The molding and casting operations were undertaken by Ron Street, assisted by Jesuit Temba and Moses Lilombero of the National Museum. The 1995 activities focused on patination of a cast for exhibition purposes in Dar es Salaam and making new molds and casts of the remaining sections of the 1978-79 trackway casts stored at Olduvai. For a description of the 1978-79 cast or mold sections referred to in the text, see Part X. For previous molding and casting work see the **1994 Report**.

PATINATION OF A CAST FOR DAR ES SALAAM MUSEUM EXHIBIT

Patination of a 1994 polyester cast of Section A (the long cast of the southern portion of the trackway, Appendix B in Part X) was undertaken at the National Museum in Dar es Salaam. This cast is intended for museum exhibition in Dar es Salaam.

Layers of oil-based Ronan Japan colors and acrylic artist paints were applied to the surface of the cast to obtain a chromatic replication of the colors of the Footprint Tuff as revealed in 1979 photographs. Prior to patination of the cast in Dar es Salaam, color samples and tests were undertaken in New York and presented to the GCI for approval.

Patination Process

The 1994 cast was first cleaned with soap and water. After drying, a thin coat of base color was applied to the surface of the cast (Photo 32). The base color was made by mixing Japan colors white, raw umber and black with mineral spirits. The base color was refined by adding other colors to achieve the required shades and then applying these on top of the previous layer of color. A palette of different colors originating from the base color was applied to the surface of the casting. After the mineral spirits dried, various areas of the casting were further enhanced by using acrylic water-based paints to replicate the varied shades of grey tuff. The acrylic paints are better suited for more controlled application, but were used sparingly because they tend to become thick and obscure surface detail.

The gel coat that had been applied to the cast in 1994 was a dark grey color, which was muted by applying multiple layers of base Japan colors to the casting. Although this resulted in a good likeness to the 1978-9 photos, the actual trackway surface, as revealed in the 1995 excavation, is in fact lighter than the 1978-9 photos indicate.

TRANSPORTATION AND REPAIR OF THE SECTION A MOLD

The 1994 master mold of Section A was transported to Endulen camp from the Dar es Salaam Museum in order to make additional casts required for field work and exhibition at Olduvai Museum. Before transportation the mold was examined and found to have been damaged in the intervening year since its creation. The rubber section of the mold was torn in twelve different locations and repair had been attempted by National Museum staff. All but two of these repairs were removed at Endulen in an attempt to minimize future damage, and new repairs made to allow continued use of the mold. The tears were the result of lifting the mold by its edges, rather than rolling it or transporting it on its support shell.

Repairs to the rubber mold of Section A took place at Endulen camp. A map of the torn sections was made before new repairs were made (see Appendix A). All the repairs except tears T-1 and T-4 attempted in Dar es Salaam by the museum staff were removed. T-1 and T-4 were not removed because it was determined that removal would further damage the mold. The Dar es Salaam repairs that were removed at Endulen consisted of stapling the torn section together and back-pouring new rubber over the torn area from behind. The result was that the torn areas did not align and the new rubber flowed through the openings, making false artifacts on the mold face and creating new forms on the back of the mold that prevented it from resting properly in its shell. Fortunately, the mold had not been cleaned before this repair technique was implemented and it therefore could be removed fairly easily.

Once the Dar es Salaam repairs were removed at Endulen, the rubber was cleaned with acetone and realigned in the support shell. The torn rubber surfaces were then lightly abraded with a knife, cleaned with acetone and fitted together with new Dow H.S.II silicone rubber made in a paste form and placed between the edges of the torn areas. The torn areas were held together by placing weight on top of the mold to

secure the alignment of the rubber in place while the rubber paste cured. The repairs made at Endulen will only function to reduce further tearing. They will not restore the mold to its original state, and any new castings will reflect these changes to the surface of the mold face.

CASTING OF THE SECTION A MOLD

Using the repaired mold of Section A, a polyester cast was made for field use. The cast was made by laminating polyester resin and fiberglass. CCP corporation gel-coat 944X064 with color dispersion PC-80369 from American Colors was catalyzed with 1% MEKP (methyl ethyl ketone peroxide) for the first two coats of resin and applied to the mold surface. A back-up of structural fiberglass was laminated over this with CCP corporation GP resin 404832. The fiberglass was applied (laminated) twice. The first lamination used two coats of 3/4 oz. fiberglass with GP resin and the second application used one coat of 2 oz. fiberglass with GP resin, both catalyzed with 1% MEKP. After curing, the cast was cut into sections containing four prints each for use at the excavation site.

Additionally, a second polyester cast of Section A from the 1994 master mold was made at Endulen for the museum display at Olduvai .

EVALUATION OF OTHER 1978-79 MOLDS AND CASTS

The extant 1978-9 mold sections of the southern and northern trackway stored at Olduvai were evaluated for possible casting in polyester resin during the 1995 field season. There were two molds of significant portions of the trackway: Section B (southern trackway) and Section E (northern trackway). Both molds were found to be in such poor condition that castings of them would provide poorly detailed models at best. The mold of Section B was made of latex and silicone; silicone being used in the footprints only and latex for the remainder of the mold. The silicone rubber had torn, cracked, spalled and warped beyond practical use. Section E of the northern trackway was made entirely of latex. The latex of both Sections B and E had also deteriorated beyond use.

The 1978-79 polyester casts of Sections C and E were found to be in excellent condition. The Section C cast does not include prints G1-26 and G2/3-19, which are included on the mold of Section B (see Part X). Both castings have inclusions of tuff, pebbles and roots that indicate they may be the first casting made from a mold taken

directly off the trackway. These casts, like the longer southern trackway Section A cast, are important documents of the trackway as excavated in 1978-9. Because of their importance and their usefulness in re-excavation, study, and exhibition, both sections were re-molded during the 1995 field season. To date this provides a complete set of molds of all available 1978-9 casts of the hominid tracks from Site G, other than the individual prints inventoried at Olduvai this year.

MOLDING AND CASTING OF SECTIONS C AND E

Silicone rubber master molds were made of both 1978-9 polyester casts of Sections C and E. The technique and materials used to mold the two sections was the same as that used for the molding of the Section A southern trackway cast during the 1994 campaign (see **1994 Report**). Polyester castings of both molds were then made. Each mold was cast twice: once to produce a casting for field use during excavation and once for possible museum exhibition. The casting technique used was the same as previously described for the field casting of Section A. The only difference was that one-inch metal pipe was attached to the back of the museum casts to provide long term structural support. The technique for applying the metal supports is also described in the **1994 Report**.

INVENTORY AND STORAGE OF MOLDS AND CASTS

Completion of the inventory and assessment of molds and casts at the Olduvai storeroom, begun in 1994 by Jerry Podany, was completed by Angelyn Bass and Ron Street. The inventory is included in Part X as Appendix A.

All the molds, casts and remaining materials and tools used during the 1995 Endulen field season were stored at the Olduvai storeroom at the end of the work season.



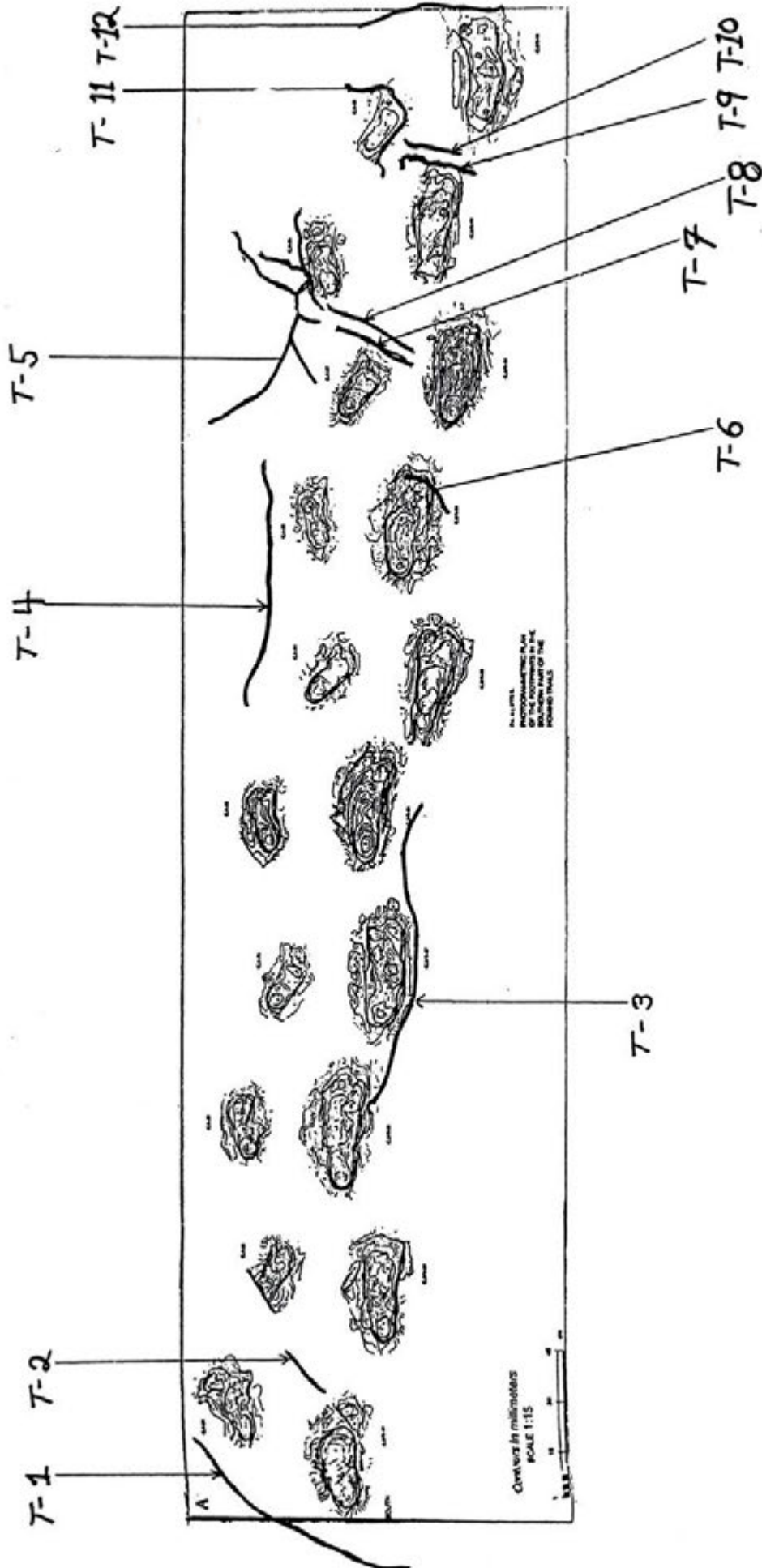

LOCATIONS OF TEARS ON SECTION A MOLD

PART XII. MINERALOGICAL AND HYDROLOGICAL STUDY

by Eric Doehne

INTRODUCTION

Questions concerning the behavior of the tuff in relation to the proposed reburial strategy for the Laetoli trackway were addressed in previous laboratory work, field work at the Laetoli site from July 16-21, 1995, and subsequent studies. Field investigations were undertaken as follows: tests of soil pH; calcium carbide meter measurements of the 1979 reburial soil and adjacent to the trackway to determine soil moisture profiles; a survey of the strike and dip of the excavated section of the trackway; and sampling and analysis of river sands considered for use in reburial. Samples of various layers of the tuff, and of the 1979 overburden material were also collected. At the GCI, tests on the river sands for their tendency to embed or penetrate the trackway tuff were undertaken, and determinations of the composition and characteristics of the final sand to be used for the 1995 reburial materials were performed. The purpose of these efforts was to characterize and determine the problems, from a mechanical and geochemical point of view, of the footprint layer and the fill to be used in reburial.

SITE OBSERVATIONS

It was clear during the excavation that the fill in the southwest part of the excavated trackway had a much higher moisture content than other areas. This is probably due to the impermeable nature of the footprint calcite-cemented layer and the resulting lack of water transport through the tuff. As water percolates through the permeable fill material it migrates downslope on the trackway surface and accumulates in the area bounded by the overlying Augite Biotite tuff at the southwest end of the trench. The accumulation of water in this southwest area provided an attractive zone for plant roots. The area of the footprint tuff near the northern end of the trench that is heavily weathered (also referred to as the "weathered tuff") exhibits polygonal cracking. The cracks appeared to open slightly after excavation, presumably due to the drying and shrinking of the clay-rich material.

The 1979 fill material generally exhibited increasing hardness with depth to the footprint layer due to the presence of a cementing material. This cemented fill material fell apart with the application of water, suggesting clay particles and soluble salts as the binder. The well preserved, calcite-cemented Footprint Tuff shows significant surface

hardness as evidenced by a lack of embedding by coarse pebbly material, except in the southern part where damp tuff allowed embedding. In contrast, the weathered tuff suffered significant embedding. The extent and distribution of the embedding is also discussed in Parts II and IV.

TESTING AND ANALYSIS

Mineralogical Composition of Tuff Samples

Appendix B presents quantitative X-ray diffraction and gravimetric analytical results on the mineralogical composition and soluble salt content of Laetoli samples.

Soil Moisture Testing

An auger was used in the field at three locations near the trackway in order to determine the subsurface distribution of moisture (see Appendix A map for locations). The holes were augered to a depth where contact with solid substratum occurred – presumably Footprint Tuff in the case of holes 1 and 2. For hole 3, stratigraphic measurements show that the trench surface of the monitoring reburial trench at Test Site 3 is at least 17 cm below the Footprint Tuff, and here no solid substrate was encountered to a depth of 66 cm. Results of the calcium carbide measurements for moisture level are summarized in Appendix C. It should be noted that the maximum reading on the carbide meter is 20% by weight, which for soils is generally considered saturated. Results of carbide meter tests of damp, 1979 reburial material sampled 10 cm above the footprint tuff surface in the SW corner of Trench 1, were 3.3 - 4.5 %. These results should be considered minimum values because of the high sand and gravel content of the 1979 reburial fill, which is not water absorbent.

pH Testing

pH was measured using narrow range indicator strips at a variety of locations: on the footprint tuff surface; in the 1979 overburden; the 1993 overburden; and on the black cotton soil. Results of 7.0-7.5 are typical pH values for the calcite-rich fill material and the footprint tuff surface. The black cotton soil was considerably more alkaline at 8.0 - 8.5 pH.

Behavior of Tuff on Wetting

Scanning electron microscopy (using the GCI's Environmental Scanning Electron Microscope or ESEM) was used to study the Laetoli tuff. A series of dynamic experiments was performed in the ESEM to determine the reaction of the two different

materials sampled from the trackway surface. Observations made in the ESEM confirm the differences in behavior observed in the field between the clay-rich weathered tuff and the calcite cemented unweathered tuff. The clay platelets in the weathered tuff exhibit expansion and contraction during wetting and drying events in the ESEM. The amount of expansion averages 10 percent over several hundred microns. Similar experiments on the unweathered tuff showed no expansion on wetting.

Sand Embedding Tests

Laboratory tests were undertaken to determine the degree of embedding of angular and rounded sand into the weathered tuff and unweathered tuff under wet and dry conditions. Small sample cubes were covered with sand and placed for six months under a stress calculated for a 1 meter-depth reburial mound. Observations under the binocular microscope were taken monthly and the degree of embedding evaluated qualitatively on a scale of 1 (no embedding) to 10 (near complete embedding). The results, summarized in Table 1, show that the type of substrate material is the most important variable, with wetness being the second most important characteristic and angularity of the particles in contact with the substrate being the least important factor.

Table 1. Relative Degree of Embedding of Fill Materials When Under Typical Load for 6 Months (scale 1-10, 10 = most embedding)

	Weathered Tuff & Angular sand	Unweathered Tuff & Angular sand	Weathered Tuff & Rounded sand	Unweathered Tuff & Rounded sand
Wet	10	4	6	3
Dry	5	2	5	1

(Angular sand from the gully adjacent to Site G; rounded sand was pure quartz sand from Unimin Corp.)

Reburial Sand

Previous evaluation of five possible river sands from Tanzania (collected by Joel Bujulu) eliminated several candidates, based on grain size, salts and angularity. Further evaluation of the Garusi River and the Kakesio river sands was undertaken to determine the composition of the layer to be used directly above the trackway surface (Layer 1 of the reburial profile). In examining the two sand types the Garusi sand was darker with more coarse grains, but more rounded than the lighter colored, more quartz rich, sub-

angular Kakesio river sand. Sufficient quantities of each were available to meet the volumetric requirements for reburial.

Sample No. 6: Kakesio River, 31 km from Endulen along the main road South-East.

Sample No. 7: Garusi River, 27 km from Endulen along the main road South-East.

Test results are given as follows (See Appendix D and Table 2):

- **Angularity** of the sands varies from subangular to subrounded. The Garusi river sand is more rounded than the Kakesio River sand, but only somewhat more, especially in the medium sand size category (Table 2).
- The **grain size distribution** for the samples varies significantly. The Garusi river sand is much coarser than the Kakesio river sand. Over half of the material (by weight) in the Garusi river sand is coarser than 1.18 mm, while the Kakesio sand contains less than 5 % over 1.18 mm (Appendix D).
- **Sorting** refers to the narrowness of the grain size distribution, with samples having wide grain size distribution (fine and coarse material together) being poorly sorted and those with narrow grain size distribution (mainly one size range present) being considered well sorted. Sorting of the Garusi sand is poor to moderate, and the Kakesio sand is moderate to well sorted (for comparison, dune sands are well sorted and flood deposits are poorly sorted).
- **Carbonate content** (based on acid-insoluble residue measurements) of the Garusi sample is high (78%) and the Kakesio sample is low (5%) (Table 2).
- The **water soluble content** of the sand samples is low; less than two weight percent in both cases. For comparison, Laetoli Tuff samples contain up to 17 weight percent soluble salts, apparently due to diagenetic reactions (Table 2).

- Analysis of **composition** of the Kakesio sand indicates variable amounts of quartz with feldspar, heavy minerals (such as tourmaline, zircon, etc.) and micas also present. The Garusi sand has a composition similar to the Laetoli tuff, which can be categorized as a volcanic limestone.

Table 2. Angularity and Sorting Results

Sample	Angularity	Sorting
#6-Kakesio	Subangular to subrounded	Moderate to Well Sorted
#7-Garusi	Subrounded to Subangular	Poor to Moderate

Carbonate and Water Soluble Content (by gravimetry)

Sample	Carbonate Content (Wt. %)	Water Soluble Content (Wt. %)
#6-Kakesio	5.0	<0.8
#7-Garusi	78	<1.9

The above results are consistent with typical sands associated with river deposits. The water soluble content of the sand samples is low, as expected for samples recently transported by water. The composition of the Kakesio sand appears to reflect the locally exposed Precambrian granitic rocks, although additional analysis is needed to confirm this determination. The composition of the Garusi river sand appears to be dominated by erosion of the Laetoli Beds.

Criteria recommended for the Laetoli reburial sand were the following: a rounded, medium to fine-grained, moderately sorted sand with significant carbonate content and low soluble salts. While none of the sand samples studied was an ideal match, the two local sands came close to fulfilling the criteria. The desirable qualities of the Kakesio river sand were its finer grain size distribution and sorting (requiring less sieving) and its light color (distinguishable from the tuff). Garusi sand contained a higher carbonate content, and more rounded shape and was poorly sorted. It was agreed that the composition of the first layer of backfill sand should be by volume 70% Garusi River sand (dark colored) and 30% Kakesio River sand (light colored), both sieved to eliminate material greater than 0.9 mm. Fines were not removed. The reburial materials are discussed in greater detail in Part XIII.

STRIKE AND DIP DETERMINATION

The footprint tuff horizon in the southern section of the trackway was determined (from data supplied by C. Cain) to have a strike of S35E and average dip of 7° in a SW direction.



Quantitative Composition of Laetoli Tuff Samples
(weight percent)

#1 Footprint Tuff Sample. Partly weathered material from between tuff layers. Sample from NW gully. Contains considerable organic material that was removed for the following analysis.

Soluble Salts ($\text{CaCl}_2 \cdot 2\text{H}_2\text{O}$; $\text{CaSO}_4 \cdot 0.5\text{H}_2\text{O}$)	Calcite (CaCO_3)	Zeolite (K, Ca-H Zeolite similar to phillipsite)	Clay (Calcium smectite)
4.5	65-70	15-20	5

#2 Calcite cemented sample of Footprint Tuff. Unweathered sample from NW gully.

Soluble Salts ($\text{CaCl}_2 \cdot 2\text{H}_2\text{O}$; $\text{CaCO}_3 \cdot 6\text{H}_2\text{O}$)	Calcite (CaCO_3)	Zeolite (K, Ca-H Zeolite similar to phillipsite)	Clay (Calcium smectite with minor kaolinite)
9-10	65-70	10-15	5

#3 Heavily weathered sample of Footprint Tuff (provided by R. Hay).

Soluble Salts ($\text{CaCl}_2 \cdot 2\text{H}_2\text{O}$; $\text{CaSO}_4 \cdot 0.5\text{H}_2\text{O}$)	Calcite (CaCO_3)	Zeolite	Clay (Calcium smectite with minor kaolinite)
16-17	65	<3	10-15

Water Content Profiles for Laetoli Tuff (Carbide Meter)

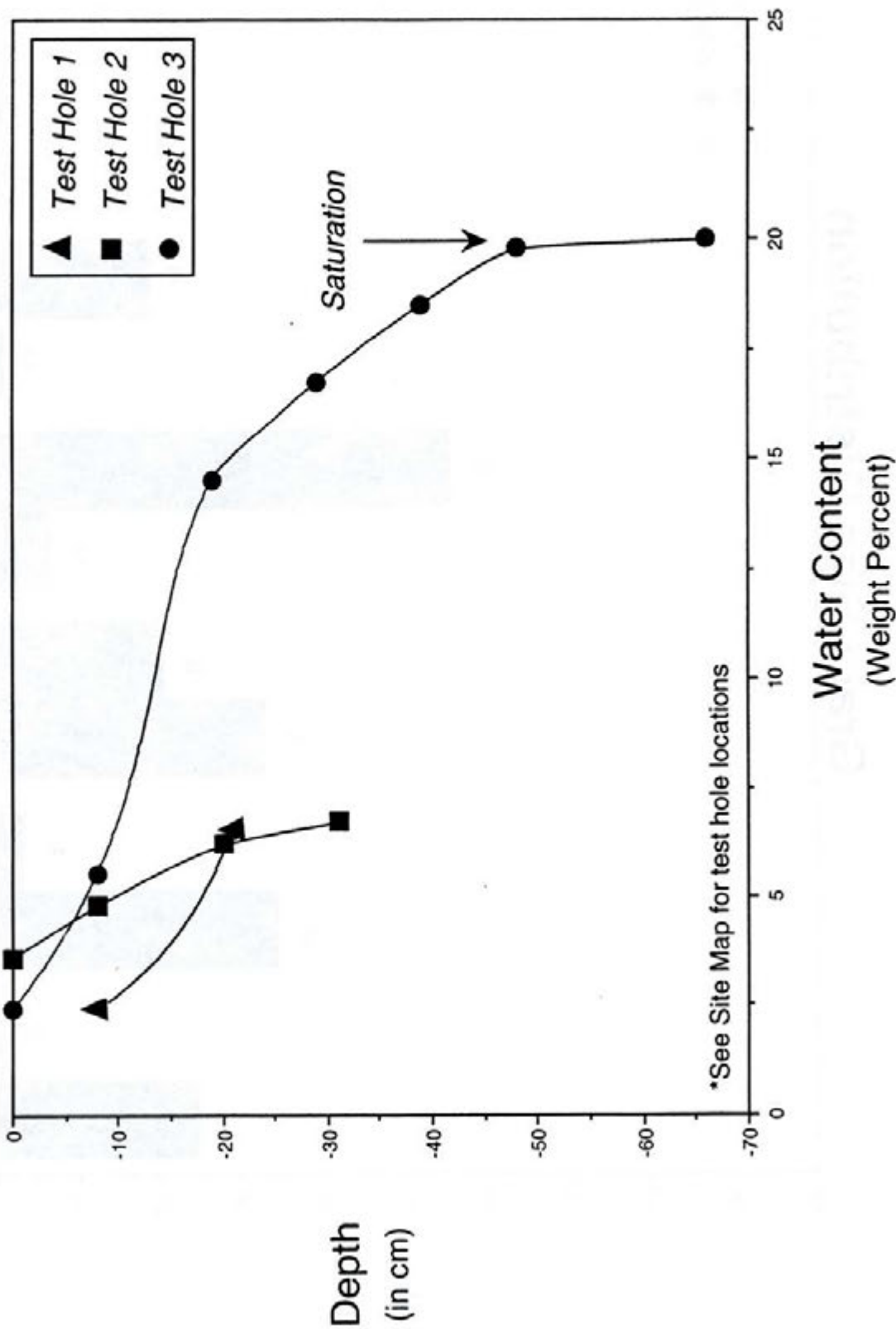

Kakesio versus Garusi River Sands: Grain Size Distribution

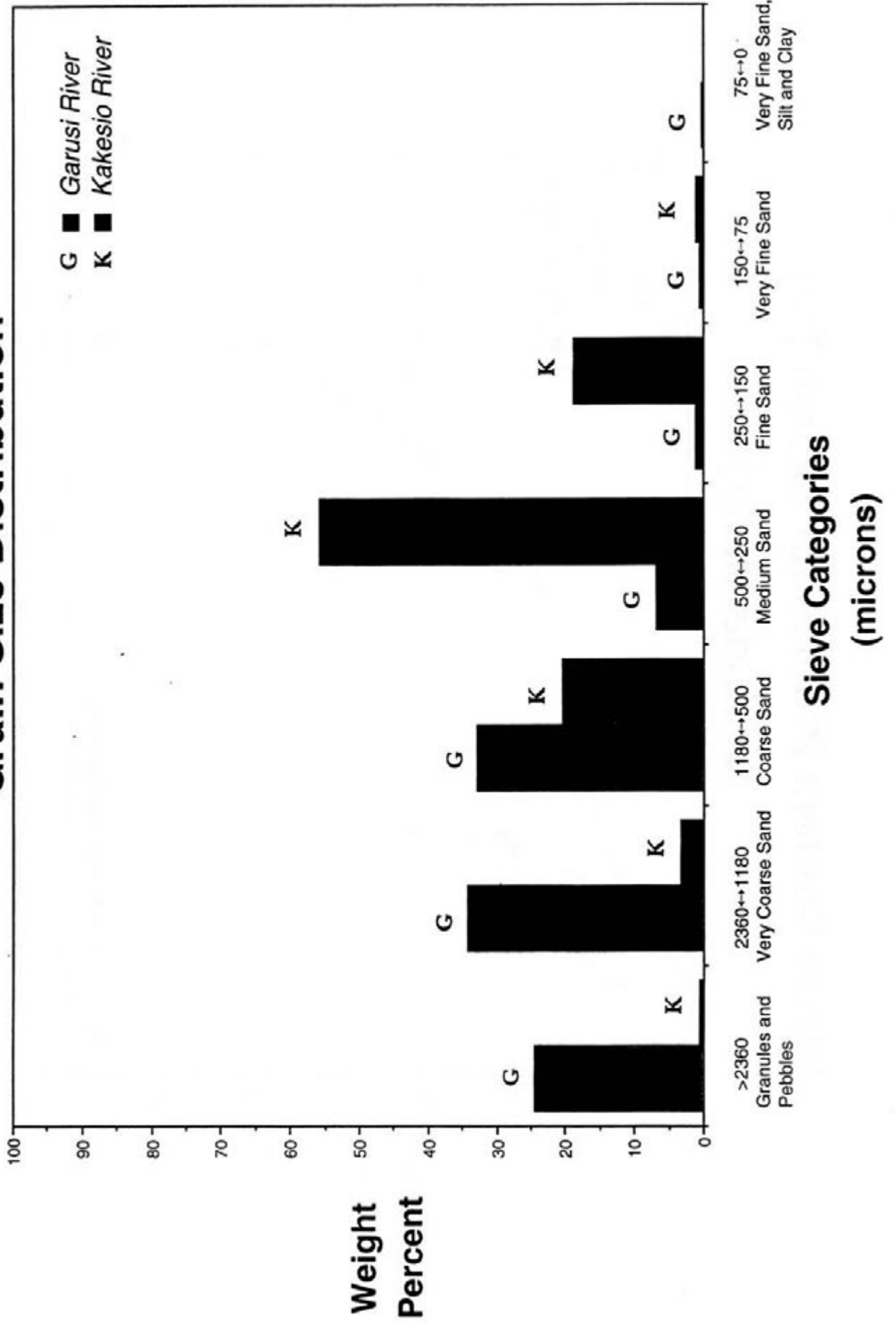

PART XIII. REBURIAL OF THE TRACKWAY AND MONITORING TRENCH

by Martha Demas, Neville Agnew and Angelyn Bass

INTRODUCTION

Reburial has been chosen as the long-term preservation measure for the trackway at Laetoli Site G. The reburial system has been designed to protect the trackway both from deterioration due to exposure and from growth of vegetation. Accompanied by routine maintenance, reburial will protect the site for the future, and is easily reversible should the decision be taken one day to open the site to public visitation or further scientific study.

Reburial of the trackway and monitoring trench (Test Site 3) took place from August 23-29. The work was supervised by Neville Agnew and Martha Demas, assisted by Angelyn Bass, Po-Ming Lin, Chet Cain, Simon Waane, Ferdinand Mizambwa, and Godfrey Olle Moita.

The reburial overburden is a composite of multiple layers of geotextile, Bio-barrier, fine granular fill, and local soil fill, mounded to a maximum height of 1m (Photo 7; Fig. 9). The function of this composite overburden is to isolate and protect the footprints from vegetation and erosion, and to maintain a stable environment at the footprint tuff surface. The mounded shape has a sufficient gradient to ensure adequate surface runoff. Extension of the composite overburden beyond each side of the excavated trackway and other mechanisms described below provide protection against lateral root migration.

SELECTION, DESCRIPTION AND PREPARATION OF REBURIAL MATERIALS

As described in Part XII, laboratory testing was conducted at the GCI to measure the tolerance of the Footprint Tuff to the overburden load and its resistance to embedding of sand under both wet and dry conditions; to determine suitable granular materials to use in the reburial; and to characterize the mineralogical and soluble salts content of the 1979 overburden. On the basis of the lab testing and field examinations it was determined that the reburial sand should be chemically stable, and consist of rounded, medium to fine grained, moderately sorted sand with significant carbonate content and low soluble salts.

Granular Fills

Several types of granular materials were considered for testing and possible use: the 1979 overburden material, five river sands from Tanzania, quartz sand, and other manufactured inert materials. After analysis and testing, two of the Tanzanian sands were selected for use in the reburial: one, a light colored sand from the Kakesio River; and the other, a dark colored sand from the Garusi River. The Garusi sand is mineralogically similar to the trackway tuff, having been derived by erosion of the Laetolil Beds. It has a high carbonate content (~40%), which will serve as a buffer against carbonic acid (from atmospheric CO₂ in rainwater). Such water percolating down through the reburial mound will become saturated with calcium carbonate and therefore be less likely to cause calcite dissolution at the footprint tuff surface. Though capillary rise of groundwater will also occur, it too will be saturated with calcium carbonate from the underlying tuff strata (see Part XII for analysis of sands).

For use in the reburial, both the Garusi and Kakesio sands were sieved through wire screens to remove large particles and organic matter. The sands were sieved dry at their source and were then transported by hired lorry and mixed on site at Laetoli.

Both sands were sieved individually through 3/16 inch (4.8 mm) wire mesh. This size screen (which passes only particles less than 4.8 mm in diameter) was chosen to eliminate *A. seyal* and *A. drepanolobium* seeds from the fill. Sand from each source was also sieved through 0.035 inch wire mesh (which passes only particles less than 0.9 mm in diameter). The fine fraction sands were mixed together and used as the first layer of sand directly covering the trackway surface.

The Garusi River sand collection area was approximately 50-100 m upstream from the intersection of the riverbed and the main road to Osinoni village, 31 km southwest of Endulen. The Kakesio River collection area was 1 km south of the Garusi River, at the intersection of the river and the main road. A total of approximately 24 m³ of coarse sand and 3 m³ of fine sand from both river beds was transported to Laetoli.

The 1979 burial fill excavated from the trackway, also Garusi River sand, was sieved for re-use. The soil was sieved through a 3/16 inch wire screen, and only sand passing through the sieve was reused in the reburial. Approximately 7 m³ of 1979 burial fill was used in the 1995 reburial, primarily in the Test Site 3 monitoring trench (4 m³).

Geosynthetic Materials

Three types of geosynthetic material were used in the reburial: Biobarrier[®], a geotextile, and Enkamat[®]. Biobarrier is a polypropylene geotextile studded with herbicide nodules that slowly release the root inhibitor *trifluralin*. *Trifluralin* is a low toxicity herbicide that is bio-degradable, is essentially water insoluble and therefore non-leaching and non-migrating, and is non-systemic, that is, it will not be absorbed by plant roots, nor kill plants whose roots contact the nodules. Biobarrier functions only to inhibit root growth in the vicinity of the fabric; the plant will not be killed, but the growth of its roots close to the fabric will be stopped. Results of an off-site test in 1993 (Test Site 3) using a layer of the Biobarrier confirmed that it blocks root growth, but does not kill vegetation; and that the released herbicide does not migrate within the soil. The Biobarrier is being used in the reburial overburden as a second line of defense against root penetration by acacias into the Footprint Tuff; the primary defense must be active site monitoring and maintenance

Typar 3401[®] geotextile is a non-woven, polypropylene fabric, light grey in color, whose tight matrix of fibers allows permeation of moisture, while acting also as a deterrent to root penetration. The permeable nature of a geotextile is essential to preventing the entrapment of moisture below, which results when using an impermeable material such as plastic. Another advantage of geotextiles is their durability in a buried environment. Testing and use of geotextiles at Laetoli in 1992, 1993 and 1994 confirmed that they caused roots, mainly weeds and grasses, to be deflected laterally where these grew in contact with the geotextile, rather than permitting them to grow vertically. There was also no evidence of insect attack or fabric deterioration.

Enkamat is a 3-dimensional, lightweight, flexible nylon matting used to control erosion of soil.

PLACEMENT OF THE REBURIAL MATERIALS

Each of the multiple layers of sand and synthetic materials was laid throughout the excavated area, covering features according to their depth. The irregular--i.e. stepped outline of the 1979 trench in the southern third of the excavated area often required tailoring the use of materials to conform with the irregularities. At the northern end of the excavated trench, a vertical separator was placed against the unexcavated portion of the mound. The separator was made of stiff plastic fencing material covered with

geotextile fabric. All fill materials were stockpiled as needed on a tarp east of the trackway trench; they were placed on the trackway by hand, using *korais* (shallow metal pans), and leveled with brushes.

The layering sequence of the reburial is as follows (Fig. 11):

Layer 1: Following conservation and documentation, the exposed trackway surface was brushed clean and then covered with a uniform 5 cm layer of fine sand from both the Kakesio and Garusi Rivers. Layer 1 was sieved to eliminate material greater than 0.9 mm (which also eliminated acacia seeds). The sands were mixed by volume 70% Garusi (dark colored) and 30% Kakesi (light colored) to achieve a sand layer visually distinct in color from the footprint tuff surface, and with a size and grain shape (predominantly subrounded to subangular) to minimize embedding into the trackway surface.

Sand was placed first in the individual footprints (Photo 33) and then to a depth of 5 cm over the trackway surface. At the southern end of the excavated trackway, Layer 1 abuts, and does not cover, the unexcavated section of Augite Biotite tuff. On the west, Layer 1 abuts the 1979 trench wall, while on the east it covers the very shallow 1979 trench wall. The function of this fine fill layer is to isolate and “cushion” the footprints, as well as to serve as a marker layer for any future re-excavation.

Geotextile: A layer of geotextile was placed over Layer 1 (Photo 34). The sheets of geotextile were placed widthwise across the trench with a 3-5 cm overlap onto the sides of the trench walls. Three sheets of geotextile, approximately 4 x 3.5 m each were needed to cover the length of the trackway; the southern piece was custom cut to fit the line of the Augite Biotite ledge and the 1979 trench walls in the southern part of the trench. Geotextile was also placed horizontally over the surface of the Augite Biotite tuff and the 1979 land surfaces (i.e. the unexcavated surfaces adjacent to the 1979 trench) in the southern third of the trench (Photo 35). In all instances, the geotextile will function as a horizon marker and separator between reburial fill layers, and in the event of any roots circumventing the Biobarrier layers above, it will serve as a final defense by deflecting growth.

Layer 2: The second layer is composed of sieved Garusi River sand, mounded over the geotextile to a height of 25 (N) -30 (S) cm at the center of the mound. The center of Layer 2 is approximately the mid-point of the 1979 trench; however on the east side the mound slopes to the 1995 trench wall, where the 1979 trench wall was very shallow. In

the southern third of the excavated trench, Layer 2 covers the Augite Biotite tuff and, very shallowly (2-3 cm), the 1979 surface on the east side only.

Biobarrier (1st layer): A layer of Biobarrier (each sheet 1.45 m wide), was laid directly over Layer 2, extending from the 1979 trench wall on the west to the 1995 wall on the east, and overlapping the vertical sides of the trench walls (Photo 35).

In the southern third of the excavated trench, a strip of Biobarrier was placed vertically along the sides of the 1979 trench walls, including in the drainage trench (see below). The placement of Biobarrier on the vertical trench walls (whether by turning up the edges of the fabric, or by separate strips of the material) is intended to protect against lateral intrusion of roots into the burial mound.

Layer 3: Layer 3, identical in composition to Layer 2, was mounded over the first layer of Biobarrier to a height of 25 (N) - 35 (S) cm at the center of the mound (Photo 35). With Layer 3 the center of the mound shifts to the west, extending from the 1995 trench wall on the east to the 1995 wall on the west. Kakesio sand was used to bulk out of the sides of the mound. Layer 3 covered all the remaining 1979 land surfaces in the southern third of the trench.

Biobarrier (2nd layer): A second layer of Biobarrier covered Layer 3, extending between the 1995 trench walls on the east and west.

Enkamat: Strips of Enkamat, 1m wide, were placed directly on top of the Biobarrier. The strips were tied together with plastic ties and pinned to the Biobarrier with wire to prevent shifting during the work. The purpose of the Enkamat was to retain the final layer of soil in two ways: by reducing slippage of the soil layer on the somewhat slick surface of the Biobarrier, and by reducing loss of soil from the surface by erosion.

Layer 4: Sieved Garusi sand was placed over the Enkamat to a uniform depth of approximately 20 cm. Layer 4 was hand-tamped into the 3-dimensional matrix of the Enkamat. The first spit of Layer 4 was the remainder of the 1979 fill, which had been sieved to obtain the finer sand used in Layers 2 and 3. The second spit was newly quarried Garusi sand, which has a wider particle size distribution since it contained all materials that passed through a 1/4 inch screen.

Layer 5: Black cotton soil, skimmed from the surface on the eastern escarpment of the site, was laid over Layer 4 and tamped down to break up clods. There are several purposes of this layer. Being a heavy, clay-rich soil it is expansive when wet and will not itself erode easily, and will function to protect Layer 4 from erosion; it will reduce water infiltration into the fill when the wet clay expands, thereby creating a more stable buried environment; it will support re-vegetation of the mound by grasses for a more natural appearance and stability of the mound against erosion; and finally, being high in carbonate content, it will provide a further chemical buffer against calcite dissolution by infiltrating rainwater.

Lava Boulder Capping: A perimeter wall of large lava boulders was first established to define the limits of the mound on the east, west, and south. A capping of medium-sized boulders was then placed over Layer 5, and chinked with small volcanic rocks and cotton soil (Photo 8). The lava boulders will provide additional protection for the trackway by serving as a physical barrier against animals and by reducing erosion of the mound.

Photo 7 shows a profile of the layers of the reburial mound from Layer 3 (bottom/south) to the boulder mounding (top/north). From east to west, the completed reburial mound is approximately 5.40-5.50 m wide, extending approximately 0.50 m beyond the 1995 trench line on the east and west.

SW CORNER DRAINAGE

As emphasized in previous sections of the report, the SW corner of the excavated trackway was very damp, a presumed result of the slope of the trackway toward the SW. The unexcavated Augite Biotite tuff at the southern end of the trackway serves to retain accumulated moisture within the SW corner of the excavated trench. There existed few options to relieve the build-up of moisture in this corner that would involve only minimal intervention (that is, no new excavation). The 1979 west trench running diagonally NW from the SW corner offered one viable solution. This feature was therefore re-excavated to provide an outlet for moisture accumulation.

The original excavation of this feature in 1979 stopped at what is presumed to represent the Upper Unit of the Footprint Tuff, which is 4.5 cm maximum above the hominid footprint surface in this corner. The 1995 re-excavation also stopped at this

Upper Unit tuff surface. The result was a trench approximately 2.20 m long and 0.55-0.60 m wide, narrowing to 0.35 m at its western end where the ground surface begins to slope down noticeably to the NW; the floor of the trench ranged from 3-4.5 cm above the footprint surface, with a slight slope to the west.

The resulting trench was not ideal for the intended purpose of draining water away from the SW corner because of the elevation of the floor of the trench above the trackway surface. However, removal of the Upper Unit tuff in order to lower the trench surface to that of the trackway was not considered a viable option since it would have exposed new footprint surface.

A drainage system was therefore designed to promote capillary rise of water from the trackway surface into the trench. A simple capillarity test was done in the field to determine whether sieved Kakesio and Garusi sands or a 30:70 by volume mixture of the two (the composition of Layer 1) would be more effective at drawing up water. The purpose of the test was to obtain information on the rate of capillary rise through the two sands, and their water holding capacity (by gravimetry) as a function of particle size fractions and sand type.

Testing was done in clear polyethylene sleeves (3 x 10 cm) sealed at one end, packed with dry sand and with pinholes in the sealed end to allow moisture ingress. Water (250 ml) was applied at the base of each of nine sleeves, filled with different sand samples and previously weighed dry. Distance of movement of water through the sand was measured after 30 minutes, and the weight of fully wetted sand was determined later. Sieved sand fractions, less than 0.9 mm in diameter (coarse and fines); less than 0.9 mm and greater than 0.09 mm (no fines); and less than 0.09 mm (fines) for each of the two sand types and the mixture of both were used. Results are tabulated in Table 1.

The rates of water migration through the two sands were comparable, but faster through the 30:70 Kakesio:Garusi mixture, which also had a higher water load, presumably because of the wider particle size distribution and better packing (i.e. poorer sorting). On the basis of these factors the 30:70 mixture was chosen as the preferred fill for the drainage trench. The sieved fraction less than 0.9 mm in diameter, which includes fines, was selected in order to provide closer packing of particles (and hence least void space) than the coarse fraction alone on the premise that this would ensure the most

stable reburial environment through intimate contact with the surface. Additionally, inclusion of fines would increase capillarity from the tuff surface into the drain and thus facilitate moisture removal.

SAND FRACTIONS (mm)	DRY WEIGHT (g)	WET WEIGHT (g)	%WEIGHT INC.	CAPILLARY RISE AFTER 30 MIN (cm)
Kakesio				
<0.9 (coarse and fines)	100.6	104.9	4.3	3.0
>0.09 <0.9 (coarse)	108.7	122.6	12.8	8.5
<0.09 (fines)	106.2	111.5	5.0	1.5
Garusi				
<0.9 (coarse and fines)	123.9	130.6	5.4	3.0
>0.09 <0.9 (coarse)	113.6	131.9	16.1	8.5
<0.09 (fines)	107.0	119.8	12.0	2.5
Kakesio and Garusi (30:70 by volume)				
<0.9 (coarse and fines)	113.3	134.5	18.7	9.0
>0.09 < 0.9 (coarse)	120.5	142.0	17.8	10.5
<0.09 (fines)	110.3	128.1	16.1	5.0

Table 1

A shallow layer of this sand (2 cm maximum at the east end to less than 1 cm at the west) was placed directly on the Upper Unit tuff in the drainage trench. A geodrain (a drain made of geosynthetic materials) was created on site, composed of a strip of 3-dimensional Enkamat material, which forms a spacer for water flow, wrapped in geotextile (Photo 34). The geodrain was placed on the sand layer, over the length of the trench and extending approximately 30 cm east of the Upper Unit tuff edge, where it rests on a slightly lower level of sand covering the footprint tuff surface. Contrary to usual practice, the Enkamat spacer was filled with sieved sand to further promote capillary rise from the lower level to the higher level of the drainage trench. Another layer of sand was placed around and above the geodrain. The first layer of geotextile in the reburial composite covered this sand and geodrain. The remainder of the drainage trench

was filled with sand and its sides lined with Biobarrier to prevent root growth into the drain.

Prior to installing the drain, an additional measure was taken to help relieve moisture build-up. Six horizontal small holes were drilled into the unexcavated Augite Biotite in the SW corner. Holes were 12 mm in diameter, averaged 10 cm in depth, and were 1-2 cm above the level of the footprint tuff surface. The holes were covered with small pieces of geotextile to prevent their being clogged with fill and held in place with the sand of Layer 1. The drilled material was found to be clayey and wet, reflecting the build-up and retention of moisture in this corner.

MONITORING REBURIAL TRENCH AT TEST SITE 3:

Test Site 3 was chosen as the location for a monitoring reburial trench. The trench replicates the method and materials used to rebury the trackway, and thus permits, at future times, re-excavation to assess conditions in the reburied environment of the trackway itself. In the context of the 1995 campaign, the reburial of the monitoring trench, which took place prior to the trackway reburial, also served as a trial run for tackling the much larger trackway reburial.

Test Site 3 is some 15 m to the east of the southern end of the trackway. The Footprint Tuff, which dips to the southwest, has eroded away in the location of the test site (Fig 1.); thus the monitoring trench is dug into the clayey stratum stratigraphically below the Footprint Tuff. Two test holes were augered to a depth of 66 cm at the site. Below about 5 cm the soil became quite moist, and carbide meter moisture measurements showed a rapid increase in water to a saturated value of 20% at a depth of 45 cm (see Part XII).

In order to excavate the monitoring trench, the 1979 spoil heap that constituted Test Site 3 was removed. The monitoring trench, 2.5 x 2.5 m, was excavated to a depth of 30-35 cm, the upper 8-15 cm representing compacted soil from the 1979 spoil heap, the lower 15-20 cm comprising the clayey stratum. The clayey stratum consisted of a lens of dark material ranging in thickness from 5-10 cm on the north, south and east trench profiles, but largely missing on the west, grading to a lighter hued and more granular material. Five live acacia trees (of the 37 that had grown in the test site mound) were left to continue growing to the north and east of the trench to monitor the

effectiveness of Biobarrier against root intrusion into the trench. The trench was divided into two replicate sections (North and South), separated by a vertically placed barrier constructed of rigid plastic fencing material wrapped in geotextile. This will allow re-excavation of half the trench (planned for 1997) with the remaining half to serve a long-term monitoring purpose.

A series of duplicate samples of different materials was prepared to provide a sensitive range of indicators of the reburial environment over the long term. Of particular interest are the survival of wood (both treated with preservative and untreated), the polypropylene geotextile used in the trackway reburial, and the effectiveness and survival of Biobarrier.

Test samples of wood (*A. seyal* and *A. drepanolobium*, stem and root), blocks of tuff, pieces of geotextile, cotton cloth, and steel nails were prepared as follows (Photo 36 shows the layout of the replicate samples in the northern and southern sections of the trench):

Wood Samples

A total of 30 dead, dry wood samples 15 cm in length, in two sets (for the north and south halves of the trench), each set numbered N or S 1-15, were gathered from the trees removed from the trackway, and from trees adjacent to it that had been treated previously with herbicide. Numbers 1-6 are *A. drepanolobium* stem; numbers 7-12 *A. seyal* stem; and 13-15 *A. seyal* root. These were set in oversize holes augered into the floor of the trench, and backfilled and tamped with the crushed and sieved material from the holes, with the cut surface of the wood remaining slightly proud of the floor.

Holes (2 x 10 mm deep) for infiltration of pentachlorophenol (PCP) wood preservative were drilled into the cut surfaces of the wood. PCP stock solution (prepared for treatment of residual roots and stumps in the trackway itself, see Part V) dissolved in acetone and isopropyl alcohol (1:1 by volume) was applied twice to samples with sufficient time between applications for absorption:

N1 and N2 : 2 x 10ml
N3 and N7 : 2 x 6ml

N8 and N9 : 2 x 2ml
N13 : 2 x 20ml

The S samples, 1-13 were likewise treated. Samples 4-6, 10-12, and 14-15, both N and S, were untreated (see also report by J. Bujulu).

It was observed that *A. drepanolobium* stem did not absorb the solution as readily as *A. seyal* stem, and that the two treated root samples of the latter (N13 and S13) were very much more absorbent than the stems.

Tuff Samples

Tuff samples, approximately 10-15 cm on edge, were collected from fallen blocks in the NW gully, and were treated with two different chemical consolidants, Stone Strengtheners OH produced by Conservare, and Silbond 40 produced by the Silbond company from a product originally developed by Akzo Chemical company. These consolidants are materials typically used for the treatment of architectural stone. Although extensive use of these materials is not intended on the trackway, the purpose here is to be able to provide long term evaluation in the buried environment in the event consolidants may be required at some future time. In addition, the water-borne acrylic emulsion Acrysol WS-24 (manufactured by Rohm and Haas Company) used in the present season's conservation work on damaged areas of the trackway was also applied to test samples of the tuff.

Duplicate samples, for the N and S sections of the trench were numbered 1-4, and prepared as follows:

N1: Acrysol WS-24, 5ml, was brushed in two applications of 2.5 ml each to the sample, with drying of several hours between applications. A very glossy surface resulted.

N2: Acrysol WS-24, diluted 1:1 with water, 5 ml was applied as above. The dry appearance was less markedly glossy than the N1 sample.

N3: Stone Strengtheners OH, 5 ml, was brushed in two applications to the surface. Very little change in appearance was noted.

N4: Silbond 40, 5 ml, was applied twice as above, with little change in appearance.

The four samples of the S series were treated in the same way, and numbered as follows:

S1 Silbond 40

S2 Stone Strengtheners OH

S3 Acrysol WS-24

S4 Acrysol WS-24, 1:1 with water

Test Block and Trench Floor Consolidation

Two additional consolidation tests were prepared by Jerry Podany. A Footprint Tuff block (recovered from the NW gully), designated "T" was prepared for consolidation and infill testing. All displacements and disruption were manufactured by wedging a chisel between the upper layer of tuff and the immediately underlying layer. Two chips were completely dislodged (area A) and re-adhered using HMG commercial B-72 adhesive. A large portion of the central section of the block (area B) was consolidated using the Acrysol WS-24 applied at full strength. After drying, a second application was made to the fractures only.

Within the disrupted area consolidated by the Acrysol two paste compositions were applied as crack infills and structural fills. In area B1 a paste made of 5g Aerosol 200 hydrophilic fumed silica with 50g of Acrysol WS-24 (pH 6.5) was applied. The paste was injected into the cracks and smoothed and dispersed with a wooden applicator stick. Below this area a roughly square section of the paste was applied to the unprepared surface. The test patch varied in thickness from 0.5 mm to 2 mm. Upon drying for one hour it became heavily cracked and 24 hours later the injections and the patch were again reapplied with additional paste.

The second paste applied in area B2 was composed of 5g Aerosil 200 hydrophilic fumed silica and 75g of Rhoplex E-330 acrylic emulsion (pH 9-9.5). The paste was applied to the fractures and undercuts as well as to a test patch in the manner described for B1. However similar shrinkage and cracking did not occur.

The last section of test block "T" was an area which was surface consolidated with one application of bottle strength Acrysol WS-24 to a prewetted surface.

Four test sections were prepared on the trench floor as follows:

1. WS-A (North): Acrysol WS-24 (diluted 1:2 with water)
2. WS-B (South): Acrysol WS-24 (diluted 1:2 with water)

WS-A and WS-B test areas were wetted with water to saturation covered with a plastic tarp and left for 30 minutes. The diluted Acrysol WS-24 was brushed on until saturation was reached. The squares were then re-covered with plastic for one hour followed by a second application. WS-A absorbed 20 cc of the solution and WS-B absorbed 10cc.

3. OH-A (North): Stone Strengthener OH (Conservare)
4. OH-B (South): Stone Strengthener OH (Conservare)

OH-A and OH-B test areas were treated with full strength Stone Strengthener OH, using a pipette until full saturation was reached (three applications five minutes apart). The squares were covered with a plastic tarp for one hour and the procedure repeated. OH-A absorbed 900 cc of solution and OH-B absorbed a total of 540 cc. The four squares were covered with plastic tarp for 24 hours.

Geotextile Sample:

Two Typar 3401 polypropylene geotextile pieces (the same material used in the reburial), per trench section, each 16 x 26 cm were laid on the floor of the trench.

Other Samples and Tests:

Two Terry cloth cotton pieces, 80 x 80 mm, were placed adjacent to the geotextile samples. The purpose was to provide a more biodegradable material than geotextile for monitoring the burial environment

Two 80mm steel nails per side were also placed in the trench to serve as indicators of corrosion effects in the reburial.

Two triangular recesses per side with sharply defined edges were cut into the floor of the trench. These are 15 cm on edge, and vary slightly in depth: numbers 1-4 are 4.0, 4.5, 5.5 and 6.0 cm deep respectively. The stratum into which the monitoring trench is excavated is different from that of the trackway (being below the Footprint Tuff). However, it is a clayey tuff akin to the heavily weathered tuff of the trackway. Here the purpose is to allow some determination of the stability of the tuff of the floor of the trench to deformation under reburial load.

Reburial of the monitoring trench

After placement of the test samples and separator barrier, the monitoring trench was buried in the same manner and with the same materials as were used on the trackway, with some minor differences. The reburial layers and any differences from the subsequent trackway reburial are noted below (see trackway reburial section above for

further description of layers). Except for Layer 1, which was newly quarried sand, all fill materials used in the monitoring trench derived from the 1979 Garusi River fill.

Layer 1: 5 cm layer of sieved sand, as per the trackway reburial. A strip of Biobarrier was also placed at this time along the vertical sides of the trench walls (Photo 37), as was done in the southern third of the trackway reburial. It should be noted, however, that Biobarrier was not placed in proximity to the footprint tuff surface in the trackway because the Biobarrier will temporarily stain materials with which it comes into contact; this was not a concern in the monitoring trench.

Geotextile: As per the trackway reburial, with no overlap on the vertical trench walls.

Layer 2: Uniform 18-20 cm layer of sieved Garusi (Photo 37).

Biobarrier (1st layer): Placed over Layer 2, overlapping onto vertical edge of trench wall. This layer of Biobarrier is only a few centimeters below the ground surface outside the trench.

Layer 3: Layer 3 was mounded to a maximum height of 35 cm; the mound was pyramidal in shape and covered the barrier separating the north and south sections.

Biobarrier (2nd layer): Placed over mounded layer 3.

Enkamat: Laid over second layer of Biobarrier and pinned to it.

Layer 4: A layer of coarsely sieved soil was laid over the Biobarrier. Layer 4 represents the final soil layer in the monitoring trench reburial.

Lava Boulders: Lava boulders were placed over Layer 4, chinked with small stones and cotton soil. Unlike the trackway burial, cotton soil was not placed as a layer below the lava boulders, but only between stones.

The test site burial mound attained a maximum height above grade of 0.85 m.

CONCLUSIONS

The reburial of the southern trackway and monitoring trench took seven days of work by twelve persons during which some 34 m³ of sieved fill was introduced onto the trackway and monitoring trench, together with the geosynthetics, and finally capped by lava boulders. The fill was moved from the staging site on the eastern escarpment to the trackway by wheelbarrows and then hand delivered using *korais* to the reburial.

The reburial design for the trackway will provide a stable environment for the footprints, one that affords protection against erosion and physical damage, and buffers the fragile surface against the destructive action of rapid wetting and drying cycles. Each element in the reburial is there for a purpose, as described in the foregoing, but especially important are the measures taken to ensure that roots from acacias do not again invade the trackway. Disturbed ground provides a fertile substrate for rapid re-vegetation, and such was the case in 1979, when it now seems certain, acacia seeds were inadvertently introduced with the reburial fill. Although re-vegetation will occur in the present reburial, and grasses will be encouraged to stabilize the soil capping, care has been taken to ensure that no acacia seeds are present. In the event that acacia seeds do find their way into the mound and germinate, the monitoring plan calls for regular inspection and removal of seedlings; the Biobarrier provides yet another level of defense.



PART XIV. SITE SECURITY AND MONITORING

by Neville Agnew and Martha Demas

INTRODUCTION

In May 1995, as a result of the disturbance to the trackway, the Antiquities Unit posted a local guard at the site. Security was augmented by the addition of a second guard during the 1995 campaign to ensure security of the exposed trackway at night. During the course of the 1995 season, a number of steps were taken to address the security needs and routine monitoring at the site for the long term. These are described below.

SITE SECURITY

At the end of the 1995 campaign, two permanent local Maasai guards were posted at the site by the Antiquities Unit. The GCI, the AU and the Ngorongoro Conservation Area Authority (NCAA) provided materials for the construction of a *boma* (traditional Maasai dwelling) near the site for their accommodation. The responsibility of the Maasai guardians has been to visit the site daily and report any disturbances or unauthorized visits to the the NCA Western Coordinator, Mr L. Mariki, stationed at Endulen village. They are also responsible for monitoring grazing of animals near the site. From the AU, Godfrey Olle Moita (based at Olduvai) was appointed principal contact for the site guards and formally monitors the site on a monthly basis, submitting reports to the AU and the GCI. This arrangement is intended as a long term security measure for the site.

SITE MONITORING AND MANAGEMENT

A provisional monitoring plan was written after the 1995 season and is the basis for routine monitoring of the site by Mr Olle Moita to inspect for vegetation, performance of drainage control measures, and disturbance.

For the long term preservation of the site, the active involvement of the NCAA is critical. On several occasions, meetings were held with NCA staff from the Research and Planning Unit and Nat Kuykendall, IUCN Technical Advisor, who were working together on the development of the General Management Plan for the Ngorongoro Conservation Area, and with Mr E. Chausi, Conservator, NCA, to discuss the needs of the Laetoli site within the framework of the management plan. Mr Mariki continues to play an important role as local liaison, facilitator and representative of the NCA.

INVOLVEMENT OF THE MAASAI COMMUNITY

In the 1994 campaign report, a description is given of a first meeting with 18 Maasai elders from the area around Laetoli to discuss with them the importance of the site and to solicit their support for its protection. In view of the site disturbance after the 1994 campaign, it was clearly necessary to follow up in 1995 with a more structured effort.

It was decided to elicit the involvement of the local *Oloiboni*, or traditional medicine man and seer, who enjoys a high reputation in the area and whose intervention, we were assured, would carry significant weight with the local population. Preliminary meetings with the *Oloiboni* were held to discuss the problems and solicit advice about the best way to proceed. Godfrey Olle Moita, Simon Waane and others established the contact and held discussions. A result of these discussions was an agreement by the *Oloiboni* to hold a traditional Maasai ceremony at the site.

The intention of the ceremony was to induct Laetoli into the heritage of the Maasai as a sacred site. While attributing added significance to the site for the local population, this, of course, does not affect its status as a protected site under the Antiquities Act. An account written by Olle Moita of the ceremony held on Sunday, August 20, 1995 is appended hereto. The day-long ceremony was attended by Deputy Principal Secretary Mrs. Malali, legal counsel to the Ministry, Mrs. Susan Mlawi, and Mr. Mamboleo, Regional Commission of Culture from Arusha, who were at that time staying at the Endulen camp. Mr. Mariki, representing the NCAA, was also present. From the villages of Esere, Endulen, and Osinoni some 68 Maasai men and 30 women attended. The executive officer of Esere (Mr Martin Osokoni) and the chairman of Endulen (Mr Augustine Pakaay Ollonyokye) spoke at the meeting, representing the villages. Mrs. Malali and Simon Waane participated in the meetings, and responded on behalf of the government.

A private, hour-long meeting of the men was held with the *Oloiboni* after sacrifice of a sheep. After this, the site was blessed and Olle Moita led the men and women in separate groups around the site while explaining the importance of the hominid footprints and the work that was being done. Permission to photograph the ceremony and meetings was given by the *Oloiboni*.

Upon the completion of the ceremony, and at the direction of the *Oloiboni*, the men from the villages started a thorn fence around the perimeter of the site to prevent cattle entering the area. Prior to the close of the season, the men returned to complete the job.

A second initiative aimed at local involvement was undertaken by Simon Waane and Godfrey Olle Moita. This was in the form of talks by Dr Waane to the schoolchildren of the villages of Esere and Osinoni about the Laetoli footprints. Additionally, steps were taken to strengthen relations with the village of Esere, to which Laetoli is geographically most proximate. Several meetings were held with the representatives of Esere, who desired a greater role in the decision-making about the site. One result has been that the permanent guards appointed by the AU are from Esere and the chairman of the village assumes a degree of responsibility for their actions.



**REPORT ON THE ROLE OF THE MASAII TRADITIONAL RELIGIOUS LEADER (OLOIBONI)
IN THE PRESERVATION OF THE LAETOLI FOOTPRINTS IN THE 1995 CAMPAIGN
by Godfrey K. Olle Moita, Antiquities Unit, Olduvai Gorge**

INTRODUCTION:

History has always been important to both the literate and illiterate. Historians are inquisitive and persistent in their search for more historical knowledge. Nature still preserves a non-discovered history for archaeologists. Sites such as Laetoli and Olduvai Gorge preserve much for us and continue to attract the attention of archaeologists who draw splendid information from them.

In a cooperative program, the Getty Conservation Institute (GCI) of California in the USA, and the Antiquities Unit (AU) of Tanzania have been working to research, guard and preserve the Laetoli footprints, which were discovered 17 years ago. This research program has been effective and has involved site work for three years so far.

Oftentimes when research is being carried out, unknown people go about the place [the Laetoli site], checking and examining to see if minerals or something of great value had been excavated. The disturbance by these unknown people leads to some destruction of the place. Therefore, the GCI and the AU discussed how the place would best be guarded and preserved.

Because of unnecessary disturbance by these people, the GCI-AU team saw a need to apply Maasai traditional methods which would lead to acknowledgment and reverence of the place. Male elders (*irpayani*) were consulted. They advised that the *Oloiboni* be appointed to initiate and thereby ritualize the very place where the ancient footprints were.

The villagers around the Laetoli area came together in ritual performance. The villagers were educated as to the importance of the place, the need for its preservation and reverence, and reasons for it being guarded.

HOW THE LAETOLI FOOTPRINT SITE WAS MADE SACRED

Although it is not easy to see the Maasai people as a religious people, they are, in fact, religious, and believe in one Supreme Spiritual Being. Their prayers are generally said in groups, performed collectively and conducted by elected elders, who are thought to have positive moral qualities.

Prior to the ceremony, Mr Birikaa Ole Kereto, a religious leader and seer (*Oloiboni*), was consulted and gave guidance on how the rituals should be performed, selection of participants, when the place would be made holy and other essential things which were required. The footprint area was first viewed, then officially announced as holy through verbal communication from one person to another. By appointing himself, the *Loiboni* showed love, courage and blessings. The delegates, who were appointed by the elders, were commissioned to spread the news from one village to another. A day was set so that many people within the villages and their neighbors could come to participate in the performance of the rituals. The *Oloiboni* offered a ram (castrated) in order to represent love, peace and unity to the male group. A sheep is given for sacrifice because it is normally thought pure and clean due to its characteristic of being obedient, calm and undisturbed. It was selected from the herd, and chosen for its light brown color.

The ram was taken to the place near to the footprint site and before it was suffocated, the *Oloiboni* gave it traditional powdered medicine (*indasimi*) passing it through the nostrils so that it sneezed out hard luck, and bad contacts from and within the place. By this process the ram became a 'scapesheep' that took away the evils of the people and of the place. The *Oloiboni* did this four times. The ram was placed to face East and after the medicine was put into its nostrils, the *Oloiboni* put the same *indasimi* to its mouth four times. It was then suffocated. It was skinned, its blood was drained from it, and the meat was roasted. Special sticks were chosen for roasting meat. These sticks were from thornless trees, *oseki* (*Cordia ovalis*) and *ormisigiyo*, both being fruit-bearing. The fire was made within a man-made hole and sticks were erected and placed both horizontally and vertically to form a four-legged table over the fire and the meat was laid on it. The chewing cuds were taken from the rumen and squeezed, their fluid mixed with some water, honey, milk and fat from roasted meat of the same ram. The combination was put into four or eight gourds capped by grass.

Eight elders, morally good, socially wealthy and married, having a great number of children of both sexes, went to the site of the footprints, blessing it with their holy prayers. They circled the site a number of times spraying the stuff from the calabash and uttering prayers of blessing.

In this way the collective decision was made so as to make the people of the region revere the site, respect its history and guard it so it remains pure. Since the Loiboni is respected and positively feared, whoever hears of this blessed place will extend news to respect and guard it. The young ones will assign themselves to seasonally visit the site and check to see that there is no vandalism.

The Maasai elders' decision brought about tribal unity and respect for what archaeologists, geologists, historians, ecologists, environmentalists, and conservationists do. The search for, and guarding of the possible origins of humankind was meant to transcend national borders to bring international awareness that sites like Laetoli and Olduvai Gorge continue to provide clues on humankind's evolution.

Afterwards, beer and soft drinks were drunk and the meat of two slaughtered goats was shared by all. Cattle herders were told to keep their herds away from this holy place, from that day of initiation onwards. A thorn fence was put around the site so as to prevent wild and domestic animals from entering the site.

PART XV. CONCLUDING REMARKS

by Martha Demas and Neville Agnew

The 1995 Laetoli campaign was successful in achieving its objectives. Excavation of 8.50 m of the southern trackway allowed conservation and documentation to be undertaken and revealed features associated with the 1979 excavation, which were recorded and mapped.

The principal and immediate threat to the trackway from the growth of acacia trees in the 1979 burial mound was eliminated and damage caused by invasive root growth into the tuff was treated. Damage was found primarily in the area of weathered tuff where in 1979 six poorly preserved hominid prints with little or no morphology were excavated, and to peripheral areas of the trackway surface. Damage to two prints was also apparently inflicted by probing of the trackway burial mound with a spear during (or after) disturbance to the site in May 1994. The presence of a layer of synthetic resin in the hominid and hipparion impressions, together with embedding of coarse sand in the trackway surface at the southern end, where it was found to be wet, have diminished the legibility of fine, sharp detail on some of the otherwise excellently preserved prints, as judged by comparison with photographs and casts from 1979.

Conservation interventions to address these problems were minimal and took the form of removal or reduction of stumps and roots, localized consolidation of the tuff and re-adherence of detached fragments, and removal of the resin layer from two prints. These interventions, however, comprise only one part of the conservation program for the trackway. The implementation of site stabilization measures, scientific documentation and condition recording strategies, enhanced security, public awareness initiatives, and reburial constitute equally significant components of a comprehensive approach to the long-term preservation of the site.

Thus, further measures were taken to address the threat to Site G from surface water erosion which has been undercutting the trackway tuff at the NW gully. Previous site stabilization from 1994 was evaluated and augmented by the addition of a new berm to divert water flow away from the trackway.

Ensuring high-quality documentation of the hominid prints for use in scientific study and assessment of condition is an important aim of the conservation program. To this end still photography in 35mm and 2.25 x 2.25 inch formats, and a photogrammetric survey of a large area of the trackway and each of the hominid prints were undertaken. The original casts of the trackway remain the most accurate three-dimensional record of the footprints as excavated in 1979. For this reason making new master molds and additional casts from 1978-79 casts at Olduvai continued.

Reburial of the trackway is the primary conservation intervention for the long-term protection and preservation of the trackway *in situ*. The 1979 reburial preserved the footprints; were it not for this far-sighted action the trackway would not have survived. The re-vegetation of the burial mound by acacia trees and the lack of regular monitoring to assess the condition of the site necessitated the present conservation project. Design of the 1995 reburial, therefore, incorporates geosynthetic materials with the specific functions of prevention of root intrusion and erosion of the mound in the future. The reburial is replicated near the trackway on a small scale to allow future re-excavation for assessment without the need to disturb the trackway.

Under separate permit from the Antiquities Unit, a restudy of the trackway was undertaken. Working together over a period of ten days, the three-member team addressed outstanding questions relating to geology, morphology and gait of the hominid footprints.

The Laetoli Consultative Committee met in Dar es Salaam in early 1995 to review and provide input to the proposed conservation program and to advise on the scientific restudy. During these meetings, emphasis was given to the perceived need for education and information for the local population on the significance of the site and the work being done, and to the long-term protection of the site on completion of the field work. This led to the implementation of permanent security measures and development of a provisional monitoring program, talks to local school children, and a traditional Maasai ceremony to make the trackway at Site G a place of special significance for the local community.

The combined GCI-AU team received the continued support of the Tanzanian government through the Ministry of Education and Culture primarily, and other ministries and agencies also facilitated the work of the project. The Ngorongoro

Conservation Area Authority staff have assisted and supported the project since its inception in 1993, and their continued efforts and willingness to engage in dialogue about the best way to protect the site in the long term, and to commit personnel and resources to this end are greatly appreciated. Representatives from the villages of Endulen and Esere have likewise continued to express interest in the project and have welcomed the team and facilitated their work in many ways.

From the outset, Mary Leakey has expressed support for the aims of the project. Her advice and encouragement before and during the 1995 field season were critical to its success. Two of the original excavators of the trackway, Tim White and Peter Jones, have generously put their knowledge and original documentation at the disposal of the team. John Harris, co-author of the Laetoli monograph, and John Reader, photographer of the 1978 and 1979 seasons, have also assisted in providing documentation, as has Richard Hay, who provided samples of tuff for analysis.

In 1996 the remainder of the trackway will be completed according to the same procedures established and implemented in 1995.



PART XVI. LAETOLI PROJECT BIBLIOGRAPHY

(June 1996)

compiled by Linda Kincheloe

- Agnew, Neville, Martha Demas, and Mary D. Leakey.** "The Laetoli footprints" (letter). *Science* 271 (22 March 1996): 1651-1652.
- Alexander, R. McN.** "Stride length and speed for adults, children, and fossil hominids." *American Journal of Physical Anthropology* 63 (1984): 23-27.
- Anderson, I.** "Who made the Laetoli footprints?" *New Scientist* 98, no. 1357 (1983): 373.
- Andrews, P. J.** "Palaeoecology of Laetoli." *Journal of Human Evolution* 18 (1989): 173-181.
- Behrensmeyer, Anna K.; and H. B. S. Cooke.** "Paleoenvironments, stratigraphy, and taphonomy in the African Pliocene and early Pleistocene." *Ancestors: The Hard Evidence*. Alan R. Liss, 1985: 60-62.
- Behrensmeyer, Anna K., and L. F. La Porte.** "Footprints of a Pleistocene hominid in northern Kenya." *Nature* 289 (15 January 1981): 167-169.
- Bowen, Robert N.** "On the track of man." *The Explorer* 21, no. 3 (September 1979): 4-11.
- Bower, Bruce.** "A walk back through evolution." *Science News* 135, no. 16 (22 April 1989): 251.
- Charteris, J., J. C. Wall, and J. W. Nottrodt.** "Functional reconstruction of gait from the Pliocene hominid footprints at Laetoli, northern Tanzania." *Nature* 290, no. 5806 (1981): 496-498.
- _____. "Pliocene hominid gait: new interpretations based on available footprint data from Laetoli." *American Journal of Physical Anthropology* 58 (1982): 133-144.
- Clarke, Ronald J.** "Early hominid footprints from Tanzania." *South African Journal of Science* 75 (April 1979): 148-149.
- Day, Michael H.** "Hominid locomotion: from Taung to the Laetoli footprints." In *Hominid Evolution: Past, Present and Future*, edited by Phillip V. Tobias. New York: Alan R. Liss, 1985: 115-127.
- _____. "The Laetoli remains." In *Guide to Fossil Man*, 4th ed. Chicago: The University of Chicago Press, 1986: 182-194.
- Day, Michael H., and E. H. Wickens.** "Laetoli Pliocene hominid footprints and bipedalism." *Nature* 286, no. 5771 (1980): 385-387.
- Deloison, Yvette.** "Empreintes de pas à Laetoli (Tanzanie). Leur apport à une meilleure connaissance de la locomotion des Hominidés fossiles." *Comptes Rendus de l'Académie des Sciences Serie II: Mécanique Physique Chimie Sciences de l'Univers Sciences de la Terre* 315, no. 1 (2 July 1992): 103-109.

- Demas, Martha, N. Agnew, S. Waane, J. Podany, A. Bass and D. Kamamba.** *Preservation of the Laetoli Hominid Trackway in Tanzania* (forthcoming in proceedings of the IIC 16th International Congress, Copenhagen, August 1996).
- Drake, R. E., and G. H. Curtis.** "Radioisotope dating of the Laetoli Beds, the Hadar Formation, and the Koobi Fora - Shungura Formations." *American Journal of Physical Anthropology* 50, no. 3 (1979): 433-434.
- Fiebel, C.S., N. Agnew, B. Latimer, M. Demas, F. Marshall, S.A.C. Waane, and P. Schmid.** "The Laetoli Hominid Footprints -- A Preliminary Report on the Conservation and Scientific Restudy." *Evolutionary Anthropology* 4, no. 5 (1996): 149-154.
- The Getty Conservation Institute.** *Laetoli Project: Project Profile.*, July 1993: 15 + attachments, figs., plates. (Unpublished report).
- The Getty Conservation Institute.** *Laetoli Project: Conservation of the Hominid Trackway Site at Laetoli, Tanzania. Report on the 1993 Field Season (August 2 - August 7, 1993)*, October 1993: 54 + attachments, figs., plates. (Unpublished report).
- The Getty Conservation Institute.** *Laetoli Project: Conservation of the Hominid Trackway Site at Laetoli, Tanzania. Report on the 1994 Field Season (May 23-28, 1994 and August 6-25, 1994)*, February 1995: 33 + attachments, figs., plates. (Unpublished report).
- The Getty Conservation Institute.** *Laetoli Project: Conservation of the Hominid Trackway at Laetoli, Site G, Tanzania. 1995 Campaign Overview*, June 1995: 14 + plates, figs. (Unpublished report).
- Harris, J. M.** "Age and paleoecology of the upper Laetoli Beds, Laetoli, Tanzania." In *Ancestors: The Hard Evidence*, edited by E. Delson. New York: Alan R. Liss, 1985: 76-81.
- _____. "Summary." *Laetoli: A Pliocene Site in Northern Tanzania*, edited by M. D. Leakey; and J. M. Harris. Oxford: Clarendon Press, 1987: 524-531.
- Hay, Richard L.** "Mililitite-carbonatite tuffs in the Laetoli Beds of Tanzania." *Contributions to Mineralogy and Petrology* 67 (1978): 357-367.
- _____. "Paleoenvironment of the Laetoli Beds." *American Journal of Physical Anthropology* 50, no. 3 (1979): 448.
- _____. "Paleoenvironment of the Laetoli Beds, northern Tanzania." In *Hominid Sites: Their Geologic Settings*, edited by George Jr Rapp; and Carl F. Vondra. Boulder, Co.: Westview Press, 1981: 7-24.
- _____. "Geology, dating, and palynology: geology of the Laetoli area." In *Laetoli: A Pliocene Site in Northern Tanzania*, edited by M. D. Leakey; and J. M. Harris. Oxford: Oxford Science Publishers, 1987: 23-47.
- Hay, Richard L., and Mary D. Leakey.** "The fossil footprints of Laetoli." *Scientific American* 246, no. 2 (February 1982): 50-57.
- Hill, Andrew.** "Appendix B: Damage to some fossil bones from Laetoli." *Laetoli: A Pliocene Site in Northern Tanzania*, edited by Mary D. Leakey; and John M. Harris. Oxford: Clarendon Press, 1987: 543-545.

- Holloway, Marguerite.** "Profile: Mary Leakey: unearthing history." *Scientific American* (October 1994): 37-38.
- Johanson, Donald C.; and Maitland A. Edey.** "Koobi Fora and Laetoli: arguments over dates and footprints." In *Lucy: The Beginnings of Humankind*. New York: Simon and Schuster, 1981: 236-252.
- Johanson, Donald C.; and James Shreeve.** "The primitive wonder." In *Lucy's Child: The Discovery of a Human Ancestor*. New York: William Morrow, 1989: 184-209.
- Jones, Peter.** "Appendix D: Recording the hominid footprints." In *Laetoli: A Pliocene Site in Northern Tanzania*, edited by M. D. Leakey; and J. M. Harris. Oxford: Clarendon Press, 1987: 551-558.
- Leakey, Mary.** "Pliocene footprints at Laetolil, Northern Tanzania." *Antiquity* 52, no. 205 (1978): 133.
- _____. "Footprints in the ashes of time." *National Geographic* 155, no. 4 (April 1979): 446-457.
- _____. "Tracks and tools." *Philosophical Transactions of the Royal Society, London, B* 292 (1981): 95-102.
- _____. "The Laetoli years." In *Disclosing the Past*. Garden City, NY: Doubleday, 1984: 168-184.
- _____. "The hominid footprints: introduction." *Laetoli: A Pliocene Site in Northern Tanzania*, edited by M. D. Leakey; and J. M. Harris. Oxford: Clarendon Press, 1987: 490-496.
- _____. "Introduction." *Laetoli: A Pliocene Site in Northern Tanzania*, edited by M. D. Leakey; and J. M. Harris. Oxford: Clarendon Press, 1987: 1-22.
- _____. "The Laetoli hominid remains." *Laetoli: A Pliocene Site in Northern Tanzania*, edited by M. D. Leakey; and J. M. Harris. Oxford: Clarendon Press, 1987: 108-117.
- Leakey, Mary; and John M. Harris.** *Laetoli: A Pliocene Site in Northern Tanzania*. Oxford: Clarendon Press, 1987: 561 p.
- Leakey, Mary, and Richard Hay.** "Pliocene footprints in the Laetolil Beds at Laetoli, northern Tanzania." *Nature* 278 (1979): 317-323.
- Leakey, Mary, Richard Hay, G. H. Curtis, R. E. Drake, M. K. Jackes, and T. D. White.** "Fossil hominids from the Laetolil beds." *Nature* 262, no. 5568 (1976): 460-466.
- Leakey, Mary; Richard Hay; G. H. Curtis; R. E. Drake; M. K. Jackes; and T. D. White.** "Fossil hominids from the Laetolil Beds, Tanzania." In *Geological Background to Fossil Man: Recent Research in the Gregory Rift Valley, East Africa*, edited by Walter W. Bishop. Edinburgh: Scottish Academic Press, 1978: 157-170.
- Lewin, Roger.** "Footsteps of the earliest ape-man." In *In the Age of Mankind: A Smithsonian Book of Human Evolution*. Washington, DC: Smithsonian Books, 1988: 50-68.

- Lovejoy, C. Owen.** *The Laetoli Footprints: A Review of Their Scientific Status in 1995*, 1 March 1995: 33 p. (Getty Conservation Institute, unpublished report).
- Ndessokia, Prosper Ndesso Sabini.** "Management plan for the Laetoli area" in *The Mammalian Fauna and Archaeology of the Ndolanya and Olpiro Beds, Laetoli, Tanzania*. Ph.D. diss., University of California, 1990: 161-166, 172-173.
- Raynal, J.** "Appendix A: List of plants collected by J Raynal from the Laetoli-Olduvai-Ngorongoro-Mt. Meru region of Tanzania." In *Laetoli: A Pliocene Site in Northern Tanzania*, edited by M. D. Leakey; and J. M. Harris. Oxford: Clarendon Press, 1987: 533-542.
- Reader, John.** "Footprints." In *Missing Links: The Hunt for Earliest Man*. London: Penguin, 1988: 218-228.
- Reynolds, Thomas R.** "Stride length and its determinants in humans, early hominids, primates, and mammals." *American Journal of Physical Anthropology* 72 (1987): 101-115.
- Robbins, Louise M.** "The hominid footprints: hominid footprints from Site G." *Laetoli: A Pliocene Site in Northern Tanzania*, edited by M. D. Leakey; and J. M. Harris. Oxford: Clarendon Press, 1987: 497-502.
- Rüther, Heinz.** *Project Design and Work Plan for the Photogrammetric Documentation of the Laetoli Footprint Site in Tanzania*, May 1995: 38 p. (Getty Conservation Institute, unpublished report).
- Salamonowicz, Paul Howard.** *Non-Metric Phototriangulation of the Laetoli Site Footprints*. M.A. thesis, Virginia Polytechnic Institute and State University, 1983: 93 p.
- Spoor, Fred, Bernard Wood, and Frans Zonneveld.** "Implications of early hominid labyrinthine morphology for evolution of human bipedal locomotion." *Nature* 369 (23 June 1994): 645-648.
- Stern, Jack T., Jr, and Randall L. Susman.** "The locomotor anatomy of *Australopithecus afarensis*." *American Journal of Physical Anthropology* 60 (1983): 279-317.
- Suwa, Gen.** "Could *Australopithecus afarensis* have made the Laetoli footprints?" *American Journal of Physical Anthropology* 63, no. 2 (1984): 224-225.
- Tattersall, Ian.** "Hadar, Lucy and Laetoli." In *The Fossil Trail: How We Know What We Think We Know about Human Evolution*. New York; Oxford: Oxford University Press, 1995: 141-158.
- Tuttle, Russel H.** "Ape footprints and Laetoli impressions: a response to the SUNY claims." In *Hominid Evolution: Past, Present and Future*, edited by Phillip V. Tobias. New York: Alan R. Liss, 1985: 129-133.
- Tuttle, Russell H.** "Bear facts and Laetoli impressions." *American Journal of Physical Anthropology* 63, no. 2 (1984): 230.
- _____. "The hominid footprints: kinesiological inferences and evolutionary implications from Laetoli bipedal trails G-1, G-2/3, and A." *Laetoli: A Pliocene Site in Northern Tanzania*, edited by M. D. Leakey; and J. M. Harris. Oxford: Clarendon Press, 1987: 503-523.

- _____. "The pitted pattern of Laetoli feet: who or what walked on the ancient African plain?" *Natural History* 99, no. 3 (1990): 60-65.
- Tuttle, Russell H., D. M. Webb, and M. Baksh.** "Laetoli toes and *Australopithecus afarensis*." *Human Evolution* 6, no. 3 (1991): 193-200.
- Tuttle, Russell H.; David M. Webb; and Nicole I. Tuttle.** "Laetoli footprint trails and the evolution of hominid bipedalism." In *Origine(s) de la Bipédie chez les Hominidés. Colloque International de la Fondation Singer-Polignac, Paris, 5-8 June 1990*, edited by Yves Coppens; and Brigitte Senut. Paris: Éditions du Centre National de la Recherche Scientifique, 1991: 187-198.
- Tuttle, Russell H., D. Webb, E. Weidl, and M. Baksh.** "Further progress on the Laetoli trails." *Journal of Archaeological Science* 17 (1990): 347-362.
- Weyl, N.** "Notes on Laetoli finds and pre-hominid radiation." *Mankind Quarterly* 18, no. 1 (1977): 71-73.
- White, Tim D.** "New fossil hominids from Laetoli, Tanzania." *American Journal of Physical Anthropology* 46 (1977): 197-230.
- _____. "Fossil hominids from the Laetoli beds, Tanzania." *American Journal of Physical Anthropology* 50, no. 3 (1979): 492.
- _____. "Additional fossil hominids from Laetoli, Tanzania: 1976-1979 specimens." *American Journal of Physical Anthropology* 53 (1980): 487-504.
- _____. "Evolutionary implications of Pliocene hominid footprints." *Science* 208, no. 4440 (1980): 175-176.
- White, Tim D., and Gen Suwa.** "Hominid footprints at Laetoli: facts and interpretations." *American Journal of Physical Anthropology* 72 (1987): 485-514.



OTHER REPORTS

LAETOLI PROJECT

Conservation of the Hominid trackway at Laetoli,
Endulen, Tanzania.

A SUMMARY REPORT ON THE
JULY - AUGUST, 1995 FIELD TRIP

BY

DR. JOEL BUJULU

P. O. BOX 7333

ARUSHA

TANZANIA

LAETOLI PROJECT

FIELD REPORT - 1995 *

The Laetoli Project is a collaborative undertaking between the Antiquities Unit of the Ministry of Education and Culture, Tanzania Government and the Getty Conservation Institute (GCI) based in Los Angeles, California, USA as a programme of the J. Paul Getty Trust.

Its main objective is to protect and conserve the hominid trackway at site G., to develop a monitoring programme for the long-term preservation of the site and to create museum exhibits for education and public awareness in Tanzania about the importance of the Laetoli site.

Laetoli, with both hominid (human-like) footprints and faunal tracks has immense scientific value for the study of human evolution. The footprints which are imprinted in volcanic ash, turned into a soft stone (volcanic tuff), are a unique evidence of bipedalism in hominids 3.5 million years ago.

The project was divided into four phases two of which were completed and reports were written by the end of 1994. Phase three to run for two years (1995 and 1996) will cover re-excavation of the trackway, conservation treatment, documentation of the hominid prints by photogrammetry, scientific re-study, reburial of the trackway to ensure long-term protection and to make additional molds and casts from the 1979 mother mold.

* Photos in this report were not available at time of printing. Alternate photo references have been added where possible.

THE FIELD CAMPAIGN

The 1995 field campaigns were undertaken between July and August. Main objectives for this season were as follows:-

1. to re-excavate 9 - 10m of the Southern part of the trackway to allow conservation, documentation and scientific re-study;
2. to conserve the footprint tuff through:-
 - stabilization of loose tuff,
 - surgically removal or reduction of root segments,
 - injection of suitable preservatives into root segments that cannot safely be removed and
 - infilling of voids left by removal of segments;
3. to carry out all documentation activities of the trackway as a whole, individual footprints and all immediate environments using various modern cameras for video films, colour black/white prints, colour slides etc. and to make surveys in order to produce a 5 mm digital elevation model (DEM) contour map of the trackway;
4. to make more molds and casts for various purposes;
5. to undertake a scientific re-study of the exposed portion of the trackway so as to improve knowledge on human evolution and
6. to rebury the trackway in the best way possible in order to achieve long-term protection against deterioration due to exposure and growth of long-rooted vegetation.

All these activities were conducted by many scientists either individually or in groups according to fields of specialization. Reports will be written by those individuals and groups and a combined report will ultimately be produced by GCI. It is not necessary therefore to produce a list of participants in this short summary report which is mainly centred at vegetation control and dry root preservation.

PRESERVATION OF REMNANT ROOTS AT LAETOLI TRACKWAY

Since it was proved beyond reasonable doubts that the most destructive element to the Laetoli hominid trackway was roots of acacia trees growing into the footprint tuff (Photo No. 5) the 1994 field campaign, among other activities, was also involved in killing all acacia trees growing directly on the trackway and within about three metres surrounding the site.

Using a common bio-degradable herbicide Roundup (glyphosate 48) all trees were treated in 1994 and subsequently died. Roots which had penetrated through the footprints were to be carefully removed but since not all could come out of the tuff, the remnants were to be preserved from termites and rotting fungi. Void spaces thus created by eaten-up roots could eventually collapse due to pressure exerted by sand, boulders and others hence damaging the footprints.

After reburial, the Laetoli trackway is not expected to be re-excavated for a number of years and it would be difficult to monitor what might happen to the preserved root remnants in future. To achieve that it was therefore agreed that Test Site 3 act as a dummy trackway, and some already killed stumps to the east of the trackway all be treated with the same preservatives. Roots of the treated stumps, pieces of roots and stems buried in Test Site 3 will be observed in 1996 and regularly thereafter to assess physical changes if any and then equate these changes to the preserved roots in the trackway; leading to timely remedial measures.

1. TREATMENT OF DEAD STUMPS TO THE EAST OF TRACKWAY

Five stumps killed in June 1994 to the north-eastern part of the trackway were selected for treatment with preservatives. They were all cut short about 2 cm from the ground using a sharp manual saw. All five were very dry and some contained termite tunnels. Beetle grubs were also found in some of the tunnels. Cut off stump pieces had several holes in them made by beetles and other borers; a clear indication that Roundup had degraded sufficiently to allow insect activity (Photo →).

(i) Stump No 1

A large stump with five (5) large drilled holes each 10 cm deep, 1.2 cm diameter and four (4) small holes of 5 cm wide, 0.6 cm diameter. This stump was treated with Pentachlorophenol Sodium salt hydrate 90% (PCP) at the rate of 61 cc of 10% W/V. The preservative was pipetted into all 9 holes and the surface was well painted. The tops were then covered with polythene to prevent evaporation of the preservative (Photo No. -).

(ii) Stump No. 2

A relatively small stump with two large and two small holes. Hole sizes were the same in all stumps as given above. This stump was treated with Zinc naphenate at 3g in 30 cc of acetone. Methods of application as in stump No. 1.

(ii) Stump No. 3

A large stump with six large and five small holes. Treated with 100 cc of 10% W/V Sodium Salt (PCP) in the same manner.

(iii) Stump No. 4 and 5

One big and one small stump originally on one stem all with nine holes. Both were treated with Cupric naphenate. 1.2 g in 20 cc of acetone.

2. TREATMENTS AT TEST SITE 3

At Test Site 3 PCP at 3.8% W/V was selected as the only preservative to be used. This was because PCP at 3.8% W/V was agreed as the most suitable for treating root remnants at the trackway.

- (i) Stem pieces of *Acacia drepanolobium*
- (ii) Stem pieces of *A. mellifera* (trackway)
- (iii) Root pieces of wood originally growing on the trackway (*A. mellifera*).

All pieces were dry. The site was divided into two halves, north and south (N & S). In each half fifteen (15) holes were dug to hold 15 pieces of stems and roots at a spacing of 25 cm apart. All holes were of the same width and depth.

TREATMENT PLAN AT TEST SITE 3

	<u>South</u>		<u>North</u>			
	S12	S6	N6	N12		
	S11	S5	N5	N11		
	S10	S4	N4	N10	N15	
S15	S9	S3	N3	N9		
S14	S8	S2	N2	N8		
S13	S7	S1	N1	N7	N13	N14

S1 to S6 and N1 to N6 were stem pieces of *A. drepanolobium*
S7 to S12 and N7 to N12 were stem pieces of *A. mellifera*
(trackway)

S13 to S15 and N13 to N15 were Root pieces originally
growing on the trackway (*A. mellifera*)

Pieces of the said samples were cut using a hand saw. They were
of equal length but different in size (Photo -, Table 1). At
one end of each piece of a hole was drilled for holding the
preservative so that it could sip slowly into the sample and
not the surrounding soil/tuff.

Preservative

Pure PCP - 90 g
Technical PCP - 100 g
Aceton - 2.5 l
Isopropyl alcohol - 2.5 l

The 190 g of PCP were dissolved in Aceton and Isopropyl alcohol
by shaking the mixture vigorously to produce a solution of
3.8% PCP w/v.

Pieces of stems and roots

All pieces were marked either N or S to indicate the Test Site
side which it was irrected (N for northern and S for southern
sides respectively). They were then numbered 1 to 15 and their
diameter (D) in cm measured (Table 1).

Table 1: Sample sizes and amount of PCP applied to them

STEM/ROOT NUMBER	DIAMETER IN CM	PCP IN ML 1ST APPL.	2ND APPL.
S1	4.0	10 ml	10 ml
S2	3.5	10	10
S3	3.5	6	6
S4	3.5	NIL	NIL
S5	4.1	NIL	NIL
S6	3.5	NIL	NIL
S7	3.5	6	6
S8	2.5	2	2
S9	3.5	2	2
S10	4.0	NIL	NIL
S11	3.5	NIL	NIL
S12	3.5	NIL	NIL
S13	8.0	20	20
S14	7.5	NIL	NIL
S15	6.0	NIL	NIL
N1	4.5	10	10
N2	4.5	10	10
N3	4.0	6	6
N4	4.0	NIL	NIL
N5	3.5	NIL	NIL
N6	4.0	NIL	NIL
N7	4.5	6	6
N8	4.0	2	2
N9	4.0	2	2
N10	3.5	NIL	NIL
N11	3.0	NIL	NIL
N12	4.5	NIL	NIL
N13	4.5	20	20
N14	6.0	NIL	NIL
N15	3.5	NIL	NIL

Treatment:

After being marked, the samples were firmly placed in their respective holes (Photo No. 36). The preservative, PCP 3.8% W/V was pipetted into the holes on the same day but in two applications after an interval to allow the first doze to seep into the wood (Table 1).

Reburial:

Although a detailed report on methods of reburial will come from the GCI staff, Test Site 3 was reburied with the following layers:- (Also see Photo No. 7)

- 1st Layer - Fine sieved sand from Garusi and Kakesio Rivers well mixed; 5 cm high.
- 2nd layer - A geotextile without herbiced nodules - TYPAR 3401.
- 3rd layer - Sieved sand from Garusi River.
- 4th layer - A bio-barrier with nodules of a root in hibitor triflualin. This is a low toxicity herbicide, biodegradable, insoluble in water, non-leaching, non-migrating and non-systemic.
- 5th layer - Garusi river sand.
- 6th layer - Bio-barrier and Enkamat (a flexible nylon mesh)
- 7th layer - Garusi River sand.
- 8th layer - Boulders with black soil.

3. TREATMENT OF ROOT REMNANTS AT THE SOUTHOURN HALF
OF THE TRACKWAY:

After carefully cutting off all roots and surgically removing the rest of removable remnants from the tuff, quite many root parts that could not be removed without damaging footprint tuff were still numerous and had to be preserved against termites and fungi. All of them were mapped and then numbered as far as possible following the original numbering given to mother trees before being killed. Roots remnants whose original numbers could not be traced due to one reason or the other were given 'letter' identities (Table 2).

The preservative, PCP 3.8% W/V as applied at Test Site 3 was pipetted into holes or carefully smeared on the entire surface of the root remnant and the amount for each was then recorded (Photo No. -). Quantities of PCP applied to each root and short notes concerning the root are given in Table No. 2.

Table 2: Roots and amount of PCP preservative applied to them on 21st and 22nd August, 1995

<u>Root No.</u>	<u>Notes</u>	<u>P C P in ml.</u>	
		<u>21st Aug.</u>	<u>22nd Aug.</u>
27	In drilled holes and cut surface	60	50
27	Exposed continuation of the same root	10	30
27.1	Rootlet on the eastern side	8	10
27.2		10	6
27.3		10	6
27.4		10	6
27.5		10	6
27.6		10	6
B	At western side	6	6
C	East of No. 27	15	20
10	In a hole and surface	6	2
18	In a hole which had a termite tunnel (Photo No. -)	10	4
19	In three holes	50	34
21	Three roots	50	10
24	Treated once on 28/8/95	-	6
D	A small root north of No. 21	6	8
E	Horizontal west of No. 21	2	2
F	Two small roots east of No. 21 - surface treatment	2	10
82	With two holes	10	6
154	One hole - had a termite tunnel	20	10
H		20	4
83		6	4
I	North of GI - 30	6	4
J	Roots through GI - 28 and G2/3-21	24	16
13	Consolidated and treated on 22nd only	-	6 + 6
K		6	6
L	Two holes and 8 rootlets (in holes and stem surface)	32	30
M		10	6
N	Lateral root with a hole	6	6
O	Two roots from outside of trench (each 6 ml.)	12	12

<u>Root No.</u>	<u>Notes</u>	<u>P C P in ml.</u>	
		<u>21st Aug.</u>	<u>22nd Aug.</u>
9	Two roots; the lower with fresh termite tunnels and the upper normal	-	12 + 6
4	One hole with termite tunnel	8	10
3	One central hole and 7 small	40	28
2	Two parts; lower and upper (small) (20 + 6 ml.)	26	28
1	One central hole and 4 small	20	12
Q	Three roots along the southern wall	12	12
8	One central hole and 4 small - very damaged by termites	50	32
16	One central hole 4 small	16	12
R	Three roots from western end	12	8
15	Five roots from western side	34	20
17	A root heavily damaged by termites	80	40
S	Three roots	18	20
23	Two roots one with 4 holes	34	10

Reburial of the Trackway

Reburial of the trackway will also be reported in details by the GCI staff, however the layers of reburial materials were as follows:- (Also see Photo No. 7)

1st layer (on footprints) fine sieved sand for 5 cm
(Garusi + Kakesio)

2nd layer - Geotextile

3rd layer - 25 cm of Garusi sand

4th layer - Bio-barrier

5th layer - 25 cm of Garusi sand

6th layer - Bio-barrier

7th layer - Garusi and Kakesio coarse sand

8th layer - Bio-barrier and Enkamat

9th layer - Black soil and lava boulders

NB: All used sand was sieved using different wire mesh to remove seeds and other foreign unwanted bodies.

TUFF CONSOLIDANTS - (To be reported by GCI consultants)

1. Acrysol WS - 24
Conservation Materials Ltd, 1275 Kleppe lane No. 10,
Box 2884, Sparks, Nevada, UAS, 89431
2. Conser Vare
OH stone strengthener $\text{Si}(\text{OC}_2\text{H}_5)_4$
Pro Soco Inc. P. O. Box 1578 KCKS
66117 stone Mts. USA
3. Sil Bond 40
Ethyl Polysilicate
Akzo Chemical Inco., Chicago IL 60606

WOOD PRESERVATIVES

1. Pentachlorophenol, Sodium salt hydrate, 90%
(123333 - 54 - 0) F.W. 288.35
 $\text{C}_6\text{Cl}_5\text{ONa} \times \text{H}_2\text{O}$
2. Pentachlorophenol, Tech., 86%
(87 - 86 - 5) $\text{C}_6\text{Cl}_5\text{OH}$ FW 26634 d 1.979

Manufacturer

Aldrich Chemical Co. Inc.
Milwaukee WI 53233, USA

3. Zinc Naphenate
(13767 - 32 - 31) MW 225.3

Manufacturer

K & K Laboratories, Division of ICN
Biomedicals Inc., Cleveland, Ohio 44128, USA

4. Cupric Naphthenate
ICN Biomedicals Inc., 1263 South Chillicothe Road,
Aurora Ohio 44202

SAMPLE IDENTIFICATION

A: VEGETATION

- Sample No. 1: At Trench No. 1 centre 07.05 Laetoli - Roots of
Solanum sp and Cynodon sp.
- Sample No. 2: Insect cocoons
- Sample No. 3: Bidens pilosa L (Compositae)
- Sample No. 4: Aspilia mossambicensis (Oliv) Willd
- Sample No. 5: Hypoestes vertiallans (R. Br.) Roem & Schult
(Acanthaceae)
- Sample No. 6: Crotolaria laburnifolia L (Papilionaceae)
- Sample No. 7: Punicum Cc.f. maximum (Gramineae)
- Sample No. 8: Asparagus africanus Lam (Liliaceae)
- Sample No. 9: Tagetes minuta L (Compositae)
- Sample No. 10: Chloris gayana Kunth (Gramineae)
- Sample No. 11: Abutilon hirtum (Lam) Sweet (Malvaceae)
- Sample No. 12: Hyperrhenia symbaria (Gramineae)
- Sample No. 13: Leonotis sp. (Labiatae)
Vigna sp. c.f vexillata (Papilionaceae)

B: SEEDS

Seed samples - The seeds collected from deep spots in the reburial sand at the trackway were planted in July, 1995 in the laboratory at TPRI. By the time this report was being compiled in September these seeds had not germinated. It was therefore concluded that they had stayed in the soil far too long to be viable. However, they were of *Acacia* sp.

C: TERMITES

- (a) Termites collected from Isilale Artam - (about 20 km. from Laetoli towards Olduvai)

These termites were collected from mounds in June 1995

Order: Isoptera

Family: Termitidae

Sub family: Termitinae

- (b) Termites collected from the Laetoli trackway (Stump No 17)

Order: Isoptera

Family: Kalotermitidae

Genus: Procryptotermes sp.

These are known as dry wood termites.

LAETOLI PROJECT 1995

A SUMMARY REPORT ON MOLDING AND CASTING TECHNIQUES

PREPARED BY:
JESUIT TEMBA AND MOSES LILOMBERO
NATIONAL MUSEUMS OF TANZANIA
P.O. BOX 511
SHAABAN ROBERT STREET
DAR ES SALAAM
TANZANIA

CONTENTS

- 1. INTRODUCTION

- 11. PATINATION OF A POLYESTER CAST

- 111. CASTING AND MOLDING ACTIVITIES
 - 1. PREPARATION OF POLYESTER CAST FOR FIELD WORK
USING 1994 MOLD MADE FROM 1979 CAST

 - 11. PREPARATION OF MOLDS AND CASTS FROM SECTION 'A'
AND 'C' OF THE SOUTHERN PORTION OF THE TRACKWAY

- IV. REFERENCES

1. INTRODUCTION

This report consist a summary of activities taken on molding and casting during the year 1995 Laetoli campaign to conserve the hominid track way site at Laetoli - Tanzania.

The activities undertaken were in two main categories:-

- (a) Patination of a polyester cast of the southern portion of the trackway made in 1994 from the 1979 cast.
- (b) Casting and molding activities which took place at the camp site Enduleni.

11. PATINATION OF A POLYESTER CAST FOR MUSEUM EXHIBITION

A polyester cast made in 1994 from 1979 cast was patinated at Dar es Salaam Museum. Two Dar es Salaam Museum staff Jesuit Temba and Moses Lilombero who were trained in casting and molding techniques during 1994 Laetoli campaign, learnt practically patination techniques.

The objective of patinating 1994 polyester cast was to replicate the colour and texture of the original trackway and also to uses the cast for exhibition.

Patination process: Before patinating, the cast was cleaned to remove dirty. Next three different Japan oil-based colours were mixed together and applied to the cast by using brush. During patination process, photographs taken from the trackway saved as a guide to replicate the colour and the texture of the trackway. another coat of Japan colour was applied to the first coat by trying to replicate original colour of the trackway.

The colour was left to dry before the last coat was applied. Every one was satisfied with the colour texture obtained and therefore no more colour was applied.

111. CASTING AND MOLDING ACTIVITIES

- (i) Preparation of polyster cast for field work using 1994 mold taken from the 1979 cast.

The 1994 silcon rubber and its shell was transported to Enduleni from Dar es Salaam Museum. One polyster cast was prepared for field use.

Casting process:- A tent was erected at Endulen to accommodate casting and molding process. The silicon mold was laid to the mother shell ready for molding process. Petroleum jelly was applied to the mold to avoid mold from sticking to the cast. Polyester resin was catalyzed with 1% MEKP (Methyl Ethyl Ketone Peroxide) and applied to the mold by using brush. The same procedure was repeated for the second coat of polyester resin. Next G.P. polyester resin was catalyzed with 1% MEKP and fibre glass of about 10 x 20 cm was torn into pieces and saturated with G.P. polyester resin. The fibre mat was allowed to cure and then the cast was removed from the mold. Lastly the cast was then cut into smaller segments for field use.

- ii. Preparation of molds and casts from Section A' and C' portion of the trackway.

Two silicon mold one from section A' and another from section C' were made from existing cast (see Part X, Appendix B). After preparation of silicon mold two cast were made from section A' and C' by using the following procedure:-

Two segments of the cast section A and C were washed with water. Cardboards were used to build the walls of both cast. Next two coat of PVA (Poly Vinyl Alcohol) were applied to the casts and cardboards. The aim was to avoid rubber from sticking to the cast. Next silicon rubber was catalyzed with 8% clear catalysts-tetra ethyl silicate and thixotropic additive was added to the silicon rubber. To build up the mold, rubber was applied to the cast and cardboard. Another silicon rubber was prepared without thixotropic additive, and two coat were applied to the first coat. The fourth coat of rubber was mixed with thixotropic additive and applied to the third coat and then allowed to cure for twelve hours. Next two coats of silicon rubber with thixotropic additive was applied to the fourth coat of silicon rubber. Re-calls were made by cutting strips of silicon rubber into 3.0 x 1.2 cm pieces and setting them on un-cured coat of silicon rubber. The purpose of Re-calls was to support silicon mold to the mother shell. The last coat of silicon rubber without thixotropic additive was applied to the sixthly coat. After the last coat polyester shell was cast on top of silicon rubber.

The process started by catalysing G. P. Polyester resin with 1% methyl ketone peroxide. Fibre glass of approximately 1.5 cm diameter were laid to the polyester shell running parallel to the length of the mold and at the right angle across the width of the mold. The pipes were laminated to the shell surface using fibre glass saturated with G.P. resin. G.P resin was allowed to cure.

Next the shell were removed from both silicon molds and rubber mold were pulled from casts. After preparation of two silicon rubber from section A' and C' of the cast, two polyester casts were prepared one from section A and another from section C. The casts were prepared using the same manner to the first one.

- (iii) Preparation of polyester cast for Olduvai museum exhibition from 1994 mold.

One polyester cast was prepared for exhibition at Olduvai Museum. The cast was made from the rubber mold prepared during 1994 Laetoli Campaign. The cast prepared using the same techniques as the one made in 1994. See 1994 Laetoli project report on casting.

References:

Report on the 1994 field seasons (May 23 - 28, 1994 and August 6- 24, 1994) Summary report on molding and casting techniques by Jesuit Temba and Moses Lilombero.

MICROSTRATIGRAPHY AND TAPHONOMY OF HOMINID FOOTPRINTS AT LAETOLI
A REPORT ON THE 1995 FIELD SEASON
by Craig Feibel

Field work carried out from 14 - 21 August, 1995 at Laetoli Site G addressed several outstanding questions of a geological nature. The first was to identify elements of the stratigraphic sequence as defined by Hay (1987; Hay and Leakey, 1982) in and around the trackway. Second, the surface of the Site G trackway was examined to determine the distribution of these strata over the exposed area. The relationships between features observed in casts and photos of the trackway and the microstratigraphic components recognized on the surface were documented to aid in the interpretation of the significance of individual features. And finally, aspects of the taphonomy of the trackway were examined in order to relate elements of post-hominid modification to features of the trackway surface.

Microstratigraphy

The stratigraphic components of Tuff 7 at Laetoli were described in detail by Hay (1987), and many of these features were readily identifiable on the surface of the trackway or in nearby exposures. The best area for viewing the sequence and characteristics of Tuff 7 in the immediate vicinity of the Site G trackway is some 30 m East of the site. There a small fault has uplifted the Tuff 7 sequence by about one meter. The Lower and Upper Units of the Footprint Tuff as well as the overlying Augite Biotite Tuff are well exposed here. Within the Footprint Tuff, the individual layers described by Hay can all be recognized, and most display the characteristics he described in terms of presence or absence of footprints, raindrop impressions, erosional features, etc. The surface which the hominids walked on, termed Horizon B (Hay and Leakey, 1982; Figure 1) can be identified here as well.

The conditions of study of the trackway itself posed certain difficulties. Mary Leakey's team had already excavated most of the strata overlying the footprints at Horizon B, and there were no good natural breaks exposing the underlying sequence at the trackway. With only a two-dimensional perspective, and no possibility of a cross-sectional view, identification of individual strata was not at all straightforward. There are, however, clear distinguishing features which allowed the major strata to be identified and mapped. Of particular significance to this study are the three uppermost layers of the Lower Unit (termed here layers L12, L13 and L14), as well as the

lowermost layer of the Upper Unit (here layer U1). Over the southern portion of the trackway exposed in 1995, these four layers can be recognized with reasonable confidence.

Most of the trackway surface consists of the footprint surface, or Horizon B, the upper surface of L14. It is characterized by a burrowed fabric (see Taphonomy section below) which shows up as a somewhat chaotically ribbed surface. It typically has an apparent cream color (actually pinkish gray, 5YR 8/1), and is locally a smooth, fine-textured surface where the calcite layer is present. L13 can rarely be distinguished as a discrete layer on the trackway, and only locally so in nearby exposures, because it has typically been homogenized with L14 by intense burrowing activity. The underlying L12, however, shows up in a few places as a very distinctive gray tuff layer. It also shows a white surficial layer, which is probably a thin calcite coating. Where remnants of U1 are preserved on the trackway surface or in lagomorph prints, it is distinctly more gray than L14/L13.

The hominid footprints range in depth from 2.9 to 4.5 cm. The depression thus created would have displaced the underlying strata, with the bottom of the deepest prints at the stratigraphic level of L8 or even L7. The strata beneath each footprint would have been displaced and compacted, and it is not possible to determine how far down the effect of the hominid prints would have been recorded. A schematic diagram of the displacement and compaction of a typical hominid impression is given in Figure 2.

The layers L14 and L13 have an uncompacted (or untrodden) thickness of 9 mm according to Hay (1987). Where compacted beneath the hominid footprints their combined thickness is probably only a few millimeters. Due to the distinctive color difference of L12, and its textural difference as well, the occurrence of L12 at the trackway surface can be easily recognized.

The only place where L12 is exposed in direct association with the hominid tracks is in the rear portion of G2/3-25. Experimental wetting of this part of the track with alcohol revealed significant absorption, in contrast to the remainder of the track, reflecting the greater porosity of L12 exposed there. This appears to be the only point in the excavated tracks where L12 was exposed. Considering the very thin nature of the compacted L14/L13 in the tracks, this reflects very well on the skill of the excavators in recognizing the surface of Horizon B.

Taphonomy

Probably the most interesting new perspective on the tracks gained in the 1995 season was the extent to which burrowing and tunneling activity affected the trackway surface. Although tunnels and burrowing are apparent in photos and casts, and an extensive discussion of termite burrows in the surrounding area was prepared by Sands (1987), little had been written about such activities in direct association with the hominid prints. In fact, the entire extent of Horizon B exposed in the 1995 study area was bioturbated, with the sole exception of the compacted areas within the hominid (and other) footprints.

Two types of bioturbation were apparent (Figure 3). The most prevalent is a burrowed fabric, which seems to have homogenized L13 and L14 over most of the trackway. This trace consists of individual burrows which are sinuous, intertwined, and 2-3 mm in diameter. These burrows are not seen to branch, but the highly complex nature of the fabric may obscure such features. These burrows generally do not extend into the area of the footprints themselves, except along the margins and between the first and second digits. It appears that burrowers approaching the compacted ash associated with the prints diverged around the margin of the track, sometimes heading down between the digits, but avoiding the bottoms or sides of the prints. In a few rare cases, individual burrows appear within the prints. A second type of bioturbation is apparent in a series of surficial tunnels attached to the surface of L14. These tunnels appear to be filled with a light-colored material like L14, and are distinct from the gray tuff of U1 into which they protrude. These tunnels are relatively straight, branching occasionally, and are 3-5 mm in diameter.

The combination of protruding burrows along track margins and common surficial tunnels near the track margins has strongly affected the excavated appearance of the tracks (see Photo 18). The irregular raised rims to tracks such as G2/3-27 are due to prominent burrows/tunnels and unexcavated material of U1 between them, giving an impression of 'splash' marks around the periphery of the hominid print (Photo 15). The prevalence of raised rims due to burrowing also exaggerates the apparent depth of the individual prints.

Craig S. Feibel
Paleoenvironmental Research Laboratory
Department of Anthropology
Douglass Campus
Rutgers University
New Brunswick, NJ
08903-0270 U. S. A.

Report PRL95-3

References

- Hay, R. L. 1987. Geology of the Laetoli area. In: Leakey, M. D. and Harris, J. M. (eds.) *Laetoli: a Pliocene site in northern Tanzania*. Oxford University Press, Oxford. pp. 23-47.
- Hay, R. L. and Leakey, M. D. 1982. The fossil footprints of Laetoli. *Scientific American* 246(2): 50-57.
- Sands, W. A. 1987. Ichnocoenoses of probable termite origin from Laetoli. In: Leakey, M. D. and Harris, J. M. (eds.) *Laetoli: a Pliocene site in northern Tanzania*. Oxford Science Publications, Oxford. pp. 409-433.

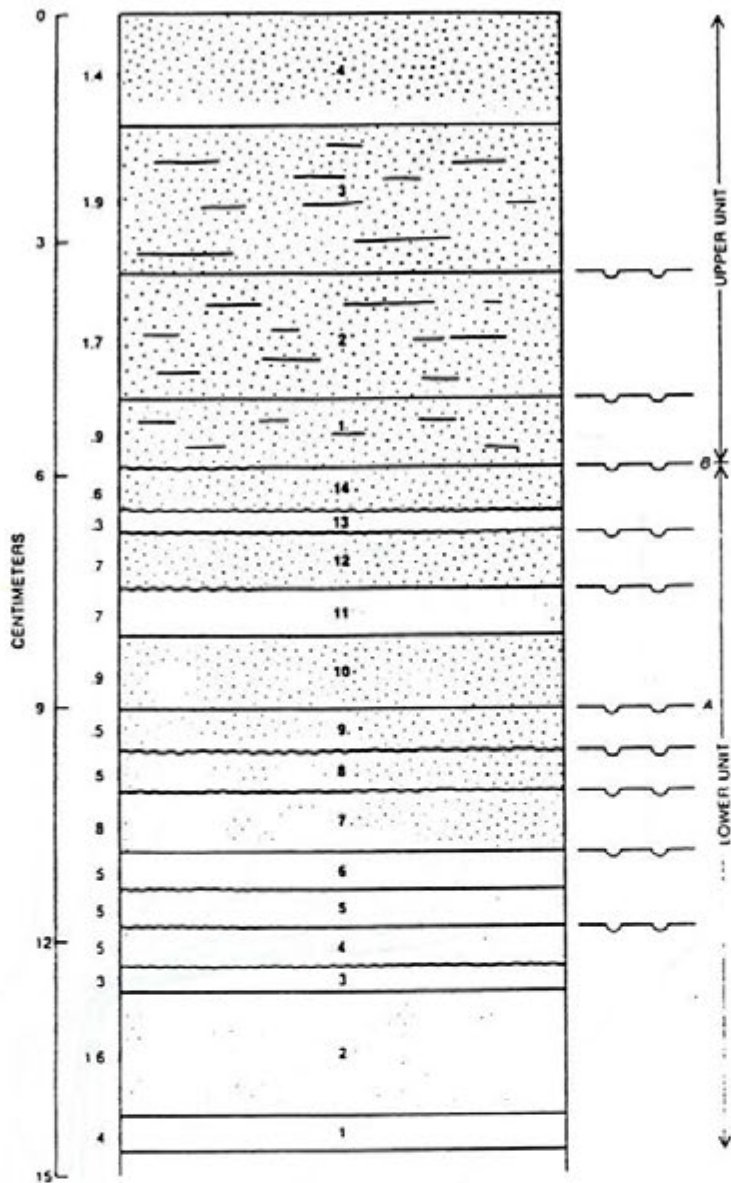

[Stippled Box] GRAIN SIZE PREDOMINANTLY 15- 4 MM [Wavy Line] FOOTPRINT HORIZON
 [Dotted Box] GRAIN SIZE PREDOMINANTLY 0.5- 5 MM [Horizontal Line] WIDESPREAD RAINPRINT HORIZON
 [Dashed Box] LAMINATION WITHIN ASH LAYERS [Wavy Line] LOCAL RAINPRINT HORIZON

FOOTPRINT TUFF is seen in section at a point where it is almost 15 centimeters thick. Of the 14 subdivisions of the lower unit eight are impregnated with tracks; the tracks are most abundant on horizons A and B. Two of the upper-unit subdivisions also bear tracks. The hominid tracks appear on horizon B. Numerals indicate the average thickness of the layers at Site A.

Figure 1. Stratigraphic terminology and characteristics of Hay.
 From: Hay, R.L. and Leakey, M.D. 1982. *The fossil footprints of Laetoli.* *Scientific American* 246 (2): 50-57.

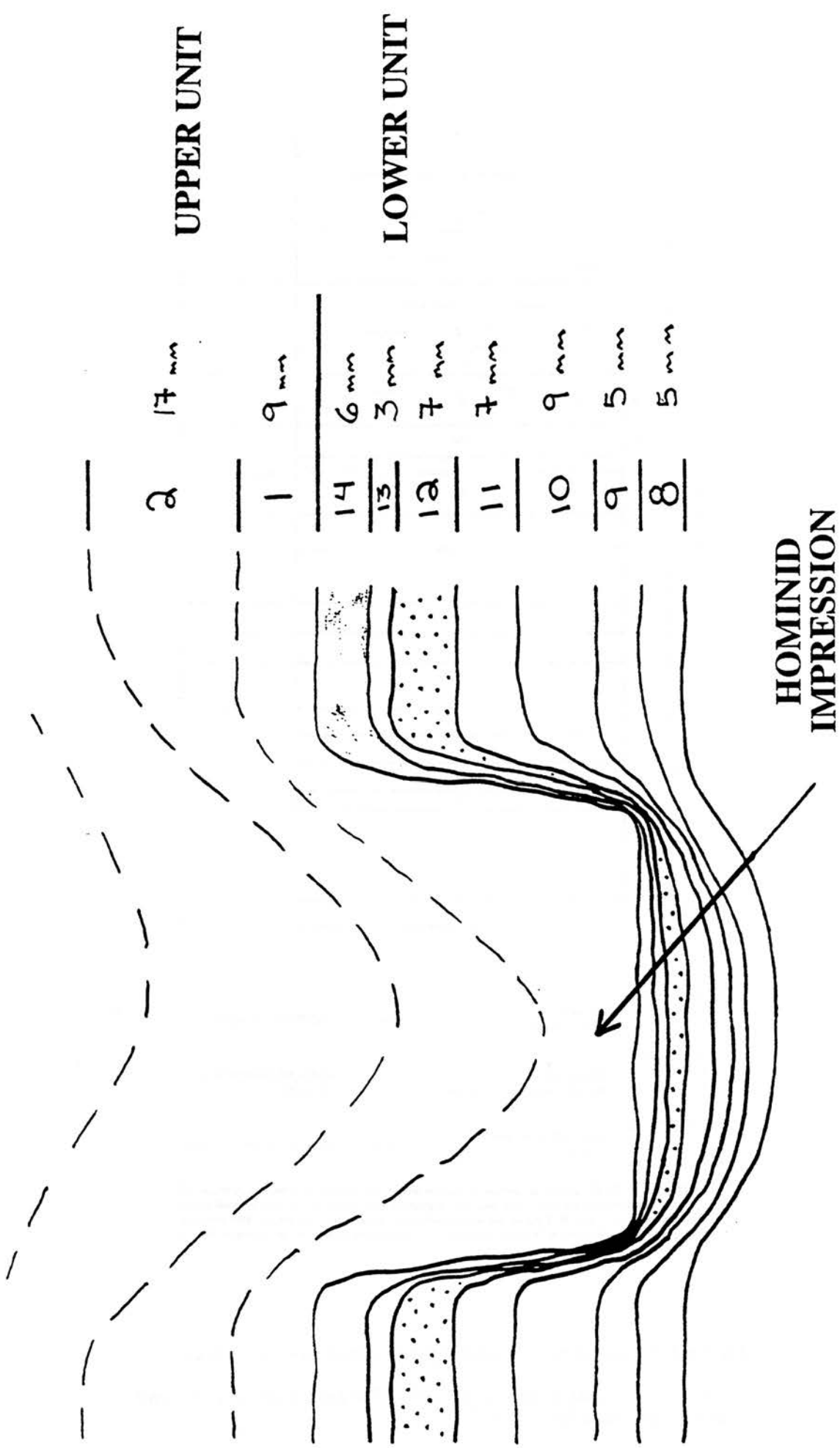

HOMINID IMPRESSION

2.9 - 4.5 cm deep

Figure 2. Diagram illustrating tephra layers involved in the formation of the hominid footprints.

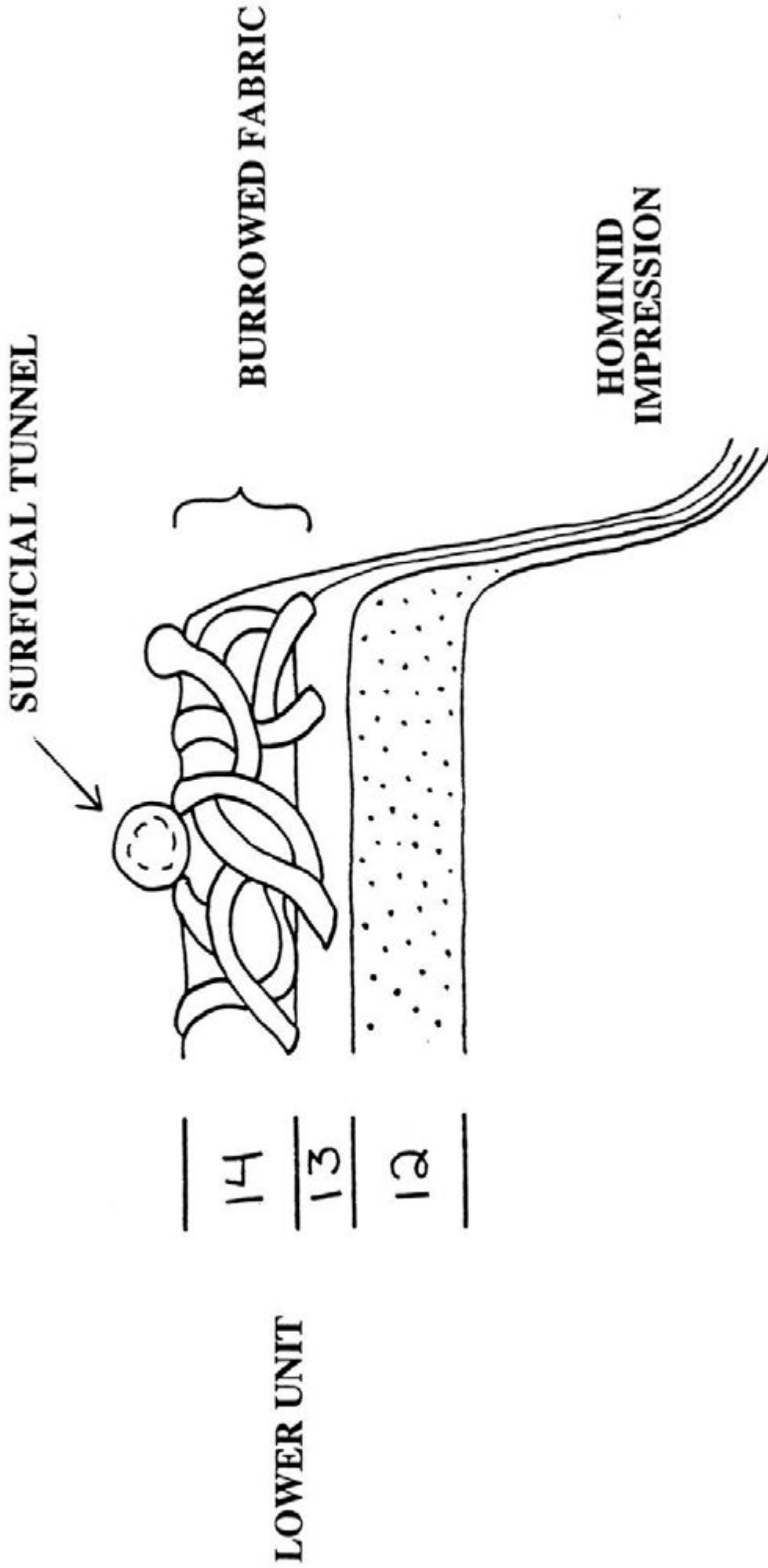

Figure 3. Diagram illustrating relationships of burrowed fabric and surficial tunnels to layers L12, L13 and L14 at the margin of a hominid print.

FUNCTIONAL INTERPRETATION OF THE LAETOLI FOOTPRINTS

The most important external force which acts on the body during progression is the force exerted on it by the ground. This force is due to the reaction to gravity and to the momentary acceleration of the body. Its magnitude can consequently be ascertained if the weight of the body and the acceleration of its centre of gravity are known.

There is considerable variation in the manner in which any individual uses his foot at different times. There is also considerable diversity in the structure of feet. The conclusions which we will reach will be based on a study of the various components acting against the ground force during walking. The relative distribution of pressure between the lateral and the medial portions of the foot is a crucial matter, not only for the functioning of the foot, but also for interpreting the fossil footprints fixed in the ash layers at Laetoli.

Ongoing experiments at Zürich

By placing a rubber mat with pyramidal projections upon an inked paper, it is possible to study the distribution of pressure in the foot of an individual walking over the rubber mat by noting the increase in area of each pyramid in contact with the ground (fig. 1).

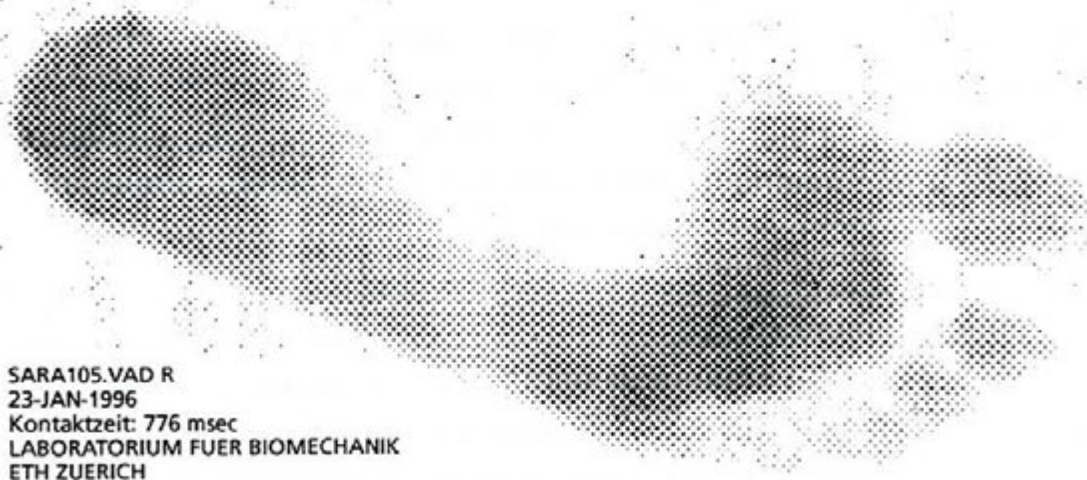

Fig.1. Footprint of a normal walking person (slightly elongated second metatarsal).

In the interpretation of the path of the force point it must be noted that the foot moves with respect to the ground, the outline of the footprint representing the total area with which the foot comes into contact during the entire step, not the outline of the footprint at any particular moment. Because of the rolling of the heel when contact is established, the heel print is longer than the area of contact when the foot is fully planted. For similar reasons, the toe prints are elongated.

In human walking, the heel first touches the ground. Initially, the pressure is very slight, the weight being still largely carried by the contralateral foot. As the weight is increasingly transferred to the foot, the pressure of the heel increases. The forward moving body causes the heel to roll forward until eventually the ball of the foot also comes into contact. As forward movement continues, the pressure transmitted by the heel decreases, that on the ball of the foot increases. Increasing pressure is exerted by the toes as the weight is released from the ball of the foot. When the heel of the contralateral foot has made contact with the ground, the weight is gradually transferred towards the great toe, resulting in decreased pressure on the part of the standing foot. The ball of this foot leaves the ground, the toes alone exerting pressure.

The point of application moves from the medial portion of the heel toward the midline of the right foot until the foot is firmly planted and then moves forward in this direction until the heel begins to rise. It then moves toward the medial border until the left foot touches the ground, after which it migrates diagonally toward the great toe.

The resultant force exerted by the ground on the body during walking is illustrated in fig. 2. Three components and the point of application of this force is shown graphically. The path which is followed by the point of application of the resultant reaction in the course of the step is usually superimposed on an outline of the footprint made by the subject on a rubber mat placed on the force plate (fig. 3).

The data obtained may also be used in a study of the movements of the body as a whole.

Odermott Sara
23-Jan-1996

SARA103.VAD R
Kontaktzeit: 664 msec

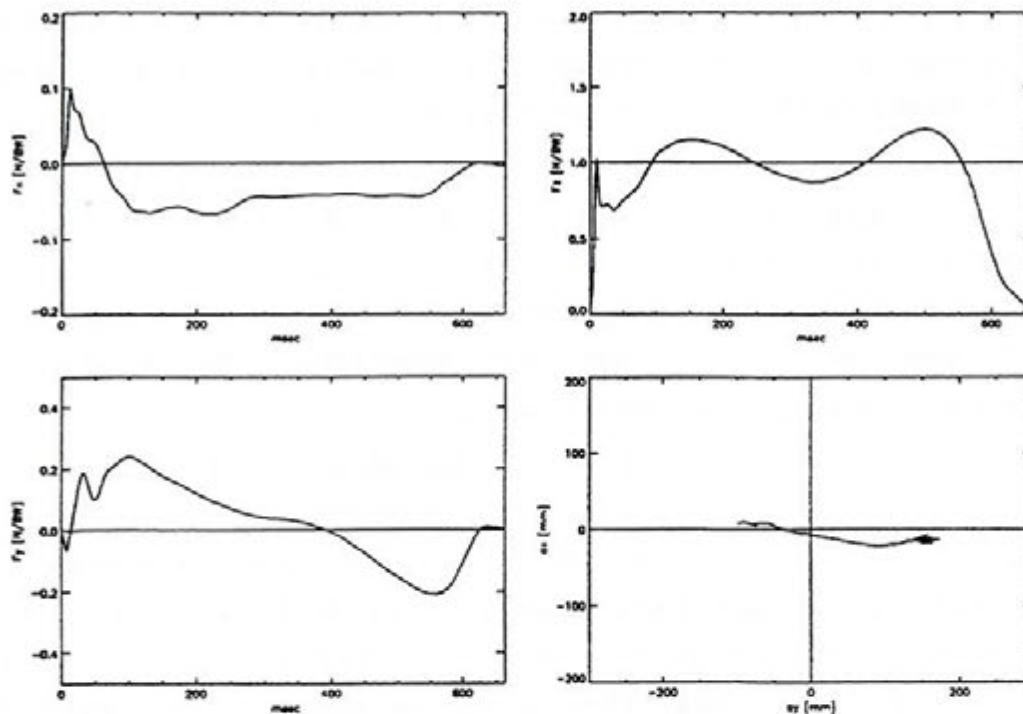

Fig.2. Force plate analysis for the print pictured in fig. 3

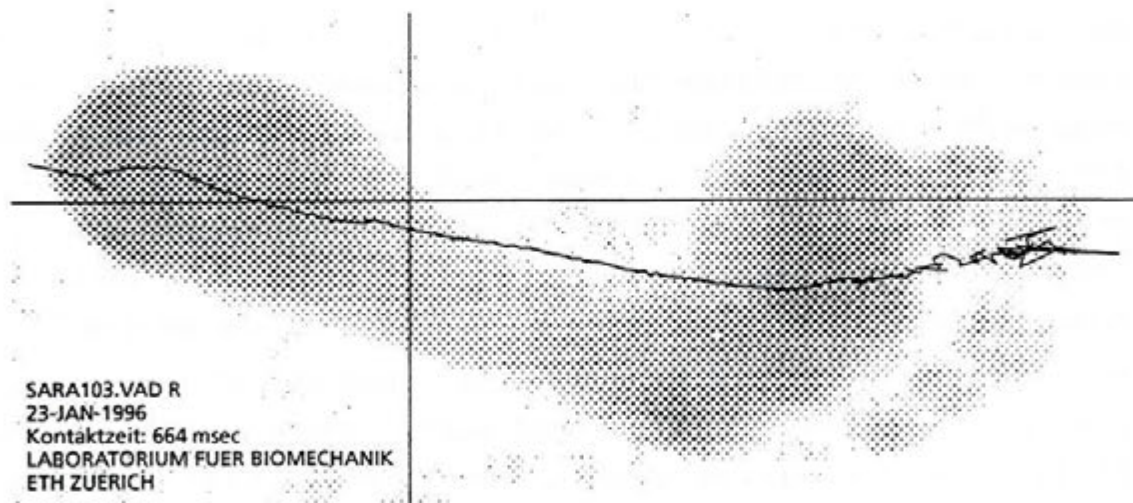

Fig.3. Course of the reaction force superimposed on the footprint

One important condition for bipedal support is the broad foot contact. Man has the possibility of using the ball of the foot for support, giving up the arboreal adaptation of his toes. This is especially important in the contraction of the calf muscles, used in walking for propelling the leg forward.

Extreme variation is to be found in the distribution of pressure in the ball of the foot.

The longitudinal arch or vault of the foot presents considerable amount of variations. When the inner arch is low, the record shows a transmission of pressure to the substratum in this region. In advanced cases of flat foot there is almost an even distribution of pressure over the foot.

The lateral portion of the longitudinal arch may be low and carry an important portion of the body pressure, without involvement of the medial arch. In this case the base of the fifth metatarsal bone may make a distinct impression on the record, and the area of the foot underlying the entire fifth metatarsal transmits notable pressure.

The transverse arch or vault is undoubtedly important in the tarsal region of the foot, but its importance in the region of the ball of the foot, at the heads of the metatarsals is considerable. The metatarsal transverse arch does not retain its dorsal curvature as the weight of the body acts on this region of the foot. When the second metatarsal is longer than the first, there is a very definite concentration of pressure at the head of the second metatarsal.

On inspection of the original footprints during the 1995 field season, we could confirm the fact that some prints show deeper impressions below the metatarsal II-V heads (Stern and Susman, 1983). This is not an uncommon condition in modern humans as White and Suwa noticed in experimental prints (White and Suwa, 1987). The major reason for this variant of weight transfer in modern humans is the placement of the foot on the ground.

With toeing out, pressure is concentrated on the lateral portion of the heel at first and when transferred to the ball of the foot is concentrated on the inner portion, frequently resulting in a concentration of pressure under the head of the first metatarsal. When the second metatarsal is longer than the first, it participates in this increased pressure (fig.3).

On the contrary, when the individual toes in, the inner border of the heel bears the greater weight, and it is transferred to the outer border of the ball of the foot. In this case the lateral toes may be the last to leave the ground.

A line joining the area bearing the greatest pressure in the heel with the area bearing the greatest pressure in the ball of the foot tends to remain parallel to the direction of progression (Elftman and Manter, 1934).

What is astonishing in the Laetoli footprints is the fact that the foot is placed in a toeing out condition, but still the impression is deepest on the lateral side of the ball.

For the moment, we try to find the mechanical reason for the differences in weight transfer. We test the hypothesis that the a difference in the rotational movements of the trunk can influence the weight transfer in the foot. In bipedal movement the fore-limb is no longer used to support against gravity or with acceleration of the body, but is primarily concerned with the rotation that the body undergoes (Elftman, 1939). The forward swing of the arm contributes angular momentum to neutralise partially that of the advancing leg of the opposite side. An analysis of the dynamics of the arm movements during walking shows that they decrease the rotation of the body as a whole about the vertical axis during the interval in which only one foot is on the ground and allow a more gradual change in the rotation of the body than would be possible without them. The arms also modify the rotation of the body about the direction of progression. The effect of the movements of the arms depends on the amplitude of their swing and on the positions through which the arms swing.

The arms do not behave as pendulums in typical walking but are subject to muscle action. The swinging of the arms is consequently not a purely incidental accompaniment of forward movement but is an integral part of the dynamics of progression.

Consequently, we analyse the weight transfer of the same person in walking normally and also in walking with different constraints on arms and trunk motion during bipedal locomotion.

Preliminary results illustrate an additional peak of the force in the Z-axis during the position of the head of the fifth metatarsal when the arms are not allowed to swing contralaterally (fig. 4a).

LABORATORIUM FUER BIOMECHANIK ETH ZUERICH

Odermatt Sara
23-Jan-1996

SARA107.VAD R
Kontaktzeit: 929 msec

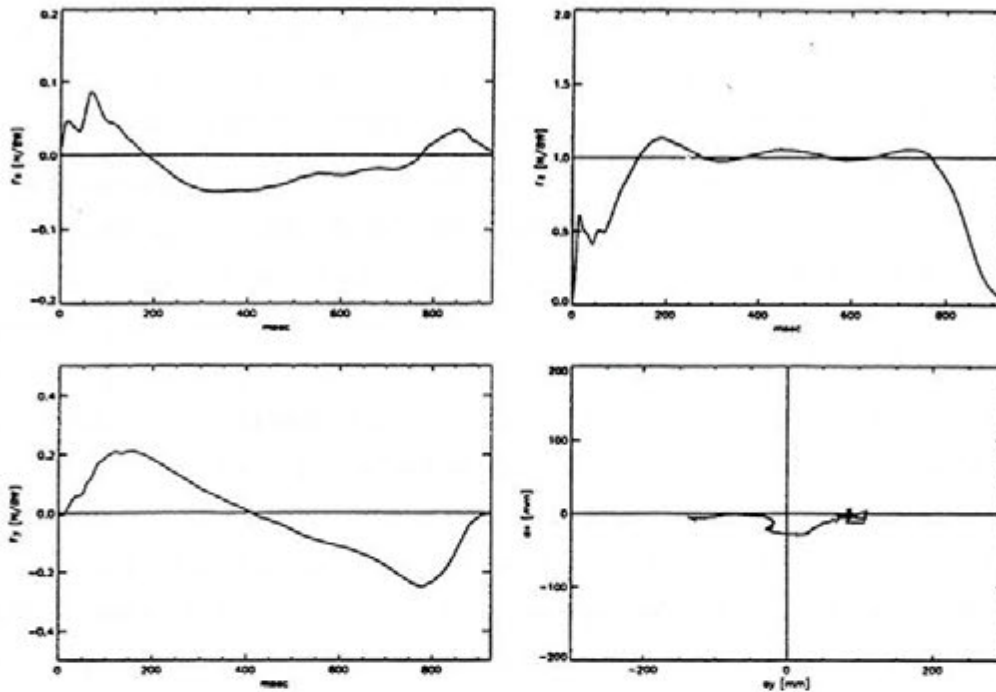

Fig.4a. Force plate analysis for a print without torsion in the trunk (additional peak in the Z-axis)

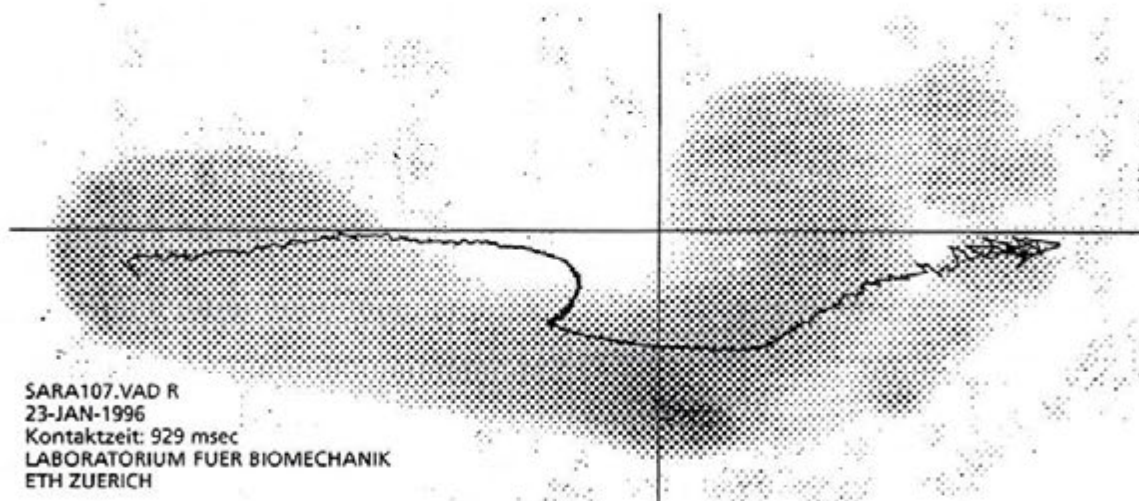

Fig.4b. Course of the reaction force superimposed on the footprint without torsion in the trunk

Our most important part will be done in the laboratory and the first results will be ready at the end of this summer.

Work to be done

Having some problems in transferring the three-dimensional information about the footprints calculated by Heinz Rüter and Julian Smit of the University of Capetown, this report cannot give interpretation of the fossil prints investigated during the 1995 field season. This will only be done after the experimental work already going on at the laboratory of biomechanics at the ETH Zürich is completed.

Our functional interpretation of the Laetoli footprints will depend on the proper description of the original fossils which will be done by C. Feibel, B. Latimer and myself. Without surveying the originals in Laetoli it is impossible to interpret the photographs and casts. This was clearly demonstrated by the recognition of the extensive effects of bioturbation. The traces of some kind of burrowing invertebrates disrupted and modified the form of the foot impression in several cases. As we could realise with the work done by Heinz Rüter and Julian Smith during a short visit in March 1996, even the interpretation of the digitised data is only possible if a clear idea based on the study of the originals precedes. For the interpretation of the three-dimensional structure representing partially the effect of weight transfer in the foot of the Laetoli hominids, a close look at the poorly documented track in the northern part of the excavation is strongly needed. Therefore we are looking forward to the field project 1996.

• Peter Schmid

References

- Elftman H (1939) The function of the arms in walking. *Human Biology* 11:529-535.
- Elftman H, and Manter JT (1934) The axis of the human foot. *Science* 80:484.
- Stern JT, and Susman RL (1983) Locomotor anatomy of *Australopithecus afarensis*. *American Journal of Physical Anthropology* 60:279-317.
- White TD, and Suwa G (1987) Hominid footprints at Laetoli: facts and interpretations. *American Journal of Physical Anthropology* 72:485-514.

**PRELIMINARY MORPHOLOGICAL ASSESSMENT
OF THE HOMINID FOOTPRINTS AT LAETOLI
A REPORT ON THE 1995 FIELD SEASON
by Bruce Latimer**

During the week of 14-21 August, 1995 the hominid trackways at Laetoli Site G (southern portion of the trackway, see accompanying reports) were examined in order to address three fundamental issues.

First, had there been any serious degradation of their individual hominid footprints in the nearly two decades since their discovery by M.D. Leakey and co-workers (see Hay & Leakey, 1982) and, if so, what effect did this have upon morphological interpretation of the prints?

Second, what important morphological features, if any, are better seen in the original footprints than in the available casts and photographs. This latter point is especially crucial in view of the fact that very few researchers have had the opportunity to examine the actual prints and there is a notable lack of agreement in published studies (e.g. Stern and Susman, 1983; White and Suwa, 1987; Tuttle et al, 1990). Moreover, careful documentation and any apparent discrepancies between the original evidence and the disseminated research materials (casts and photographs) means that future studies are less likely to make misinterpretations.

And third, from a morphological perspective, what can be learned about early hominid locomotion from these 3.5 million year old footprints?

The contemporary overall conditions of the trackways and adjacent areas are treated in the accompanying reports. The original condition of the hominid footprints as well as a preliminary view of their evolutionary significance are described by L.M. Robbins and R.H. Tuttle in Leakey and Harris (1987).

Recent examination of the exposed hominid footprints indicates that they show very little in the way of significant degradation. Although certain areas within several of the footprints do exhibit some slight polishing, perhaps owing to the compaction of the

sand used to bury the trackways, these modifications are minor and in no way disturb any important morphological details.

Perhaps the most important, if unexpected, discovery about the hominid trackways was the marked amount of bioturbation in the form of termite activity that had taken place in the area immediately adjacent to the prints. Many of the print margins have been elevated by the burrows, sometimes resulting in an exaggerated print depth. In addition, because the tunneling preferentially follows non-compacted areas, morphological features such as the space between the first and second toes may also be exaggerated. In this light, it is important to note that while the bioturbated surfaces are clearly visible on the available casts, the lack of carefully detailed and explicit descriptions may have misled some observers regarding morphology as well as substrate composition.

Overall, the hominid prints exposed during the 1995 field season are in excellent condition. From the perspective of pedal morphology, they are clear in indicating two of the primary anatomical adaptations to habitual bipedality; an adducted great toe and a longitudinal pedal arch. Both of these features occur only in hominids and are unequivocal in indicating human-like pedal anatomy. Indeed, the occurrence together of the adducted great toe and the pedal arch strongly suggests that these two structural adaptations are mechanically linked. The pedal arch can only be achieved by habitual adduction of the hallux and is an adaptation to the heightened substrate reaction forces imposed upon the hominid foot during single support phase. Dangerously high substrate reaction forces are dissipated through eccentric contraction of the plantar musculature thereby protecting the joints of the lower limb. Additional details regarding this mechanism can be found in Latimer and Lovejoy (1989).

References:

Hay, R.L. and M.D. Leakey (1982). The fossil footprints of Laetoli. *Scientific American* 246 (2): 50-57.

Stern, J.T. and R.L. Susman (1983). The locomotor anatomy of *Australopithecus afarensis*. *American Journal of Physical Anthropology* 60: 279-317.

White, T.D. and G. Suwa (1987). Hominid footprints at Laetoli: facts and interpretations. *American Journal of Physical Anthropology* 72: 485-514.

Latimer, B. and C.O. Lovejoy (1989). The calcaneus of *Australopithecus afarensis* and its implications for the evolution of bipedalism. *American Journal of Physical Anthropology* 78: 379-386.

Tuttle, R.H., D. Webb, E. Weidl, and M. Baksh (1990). Further progress on the Laetoli trails. *Journal of Archaeological Science* 17: 347-362.

PHOTOGRAPHS



1. The southern trackway as excavated in 1979. Note 1978 trench edge (center, left), 1979 east trench (center, right), and stepped edge of trench (lower right). (Photograph by John Reader.)



2. View of Site G from the south.
The white shelter canopy marks the southern trackway.

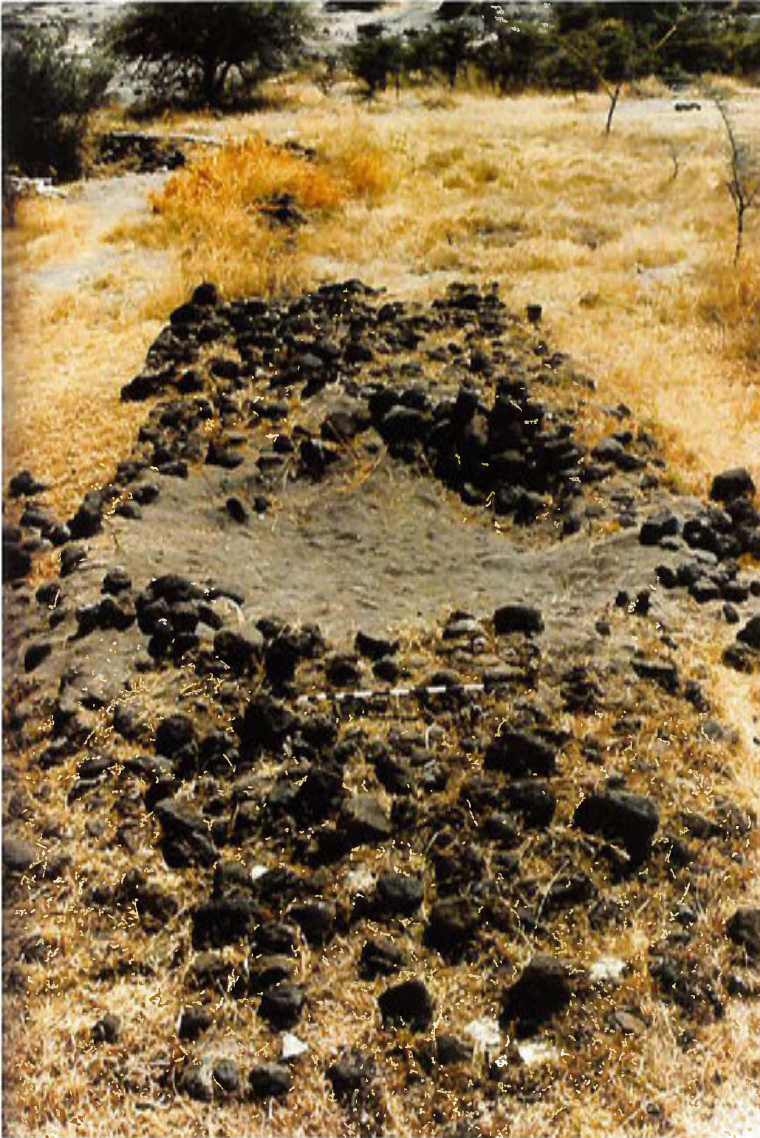

3. The southern trackway after clearing vegetation (northern trackway not yet cleared). Area of disturbance at center.



5. Southern trackway after excavation of trackway surface but before cleaning of individual prints and removal of acacia stumps. Stones blocking the southern exploratory trench and the west trench are visible.



4. Southern trackway during initial excavation of Trenches 1 (lower) and 2 (center) with baulk still in place and prior to extension of trench 0.50 m to the east. The cobble fill forming the 1979 west trench wall is beginning to appear in Trench 2; lateral acacia roots beginning to appear in Trench 1.

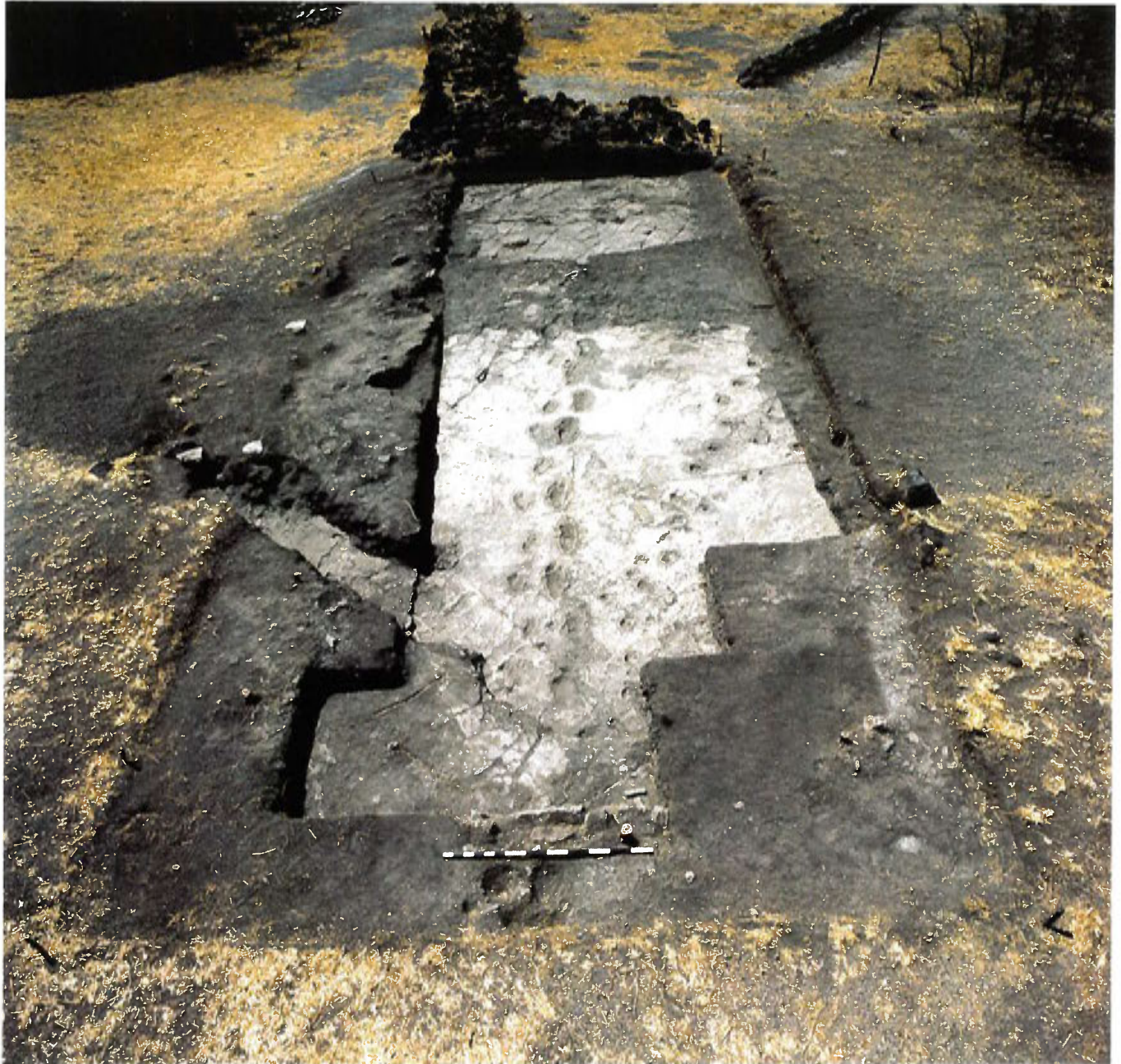

6. The southern trackway after re-excitation and conservation in 1995, from the south. Note 1979 features: Upper Unit tuff in west trench (left); Augite Biotite tuff at southernmost end of trench; southern exploratory trench with blocking stones *in situ* (near scale); and tuffaceous fill covering east land surface (lower right).



7. Profile of the layers of the reburial mound over the southern trackway. From the south (bottom of photo): Layer 3 (Kakesio sand is visible), 2nd layer of BiobARRIER, Enkamat, Layer 4, Layer 5, boulder capping.



8. Southern trackway at completion of reburial with lava boulder capping.



9. Southern trackway during excavation of the final layer of 1979 fill. Lateral roots from acacia trees in the foreground. The 1979 tuffaceous fill overlying the 1979 surface is visible in the lower right of the photo.



10. Southern trackway during excavation of the final layer of 1979 fill. In Trench 2 (lower part of photo) the footprint surface has been exposed. The 1979 cobble fill forming the west trench is visible (left center).

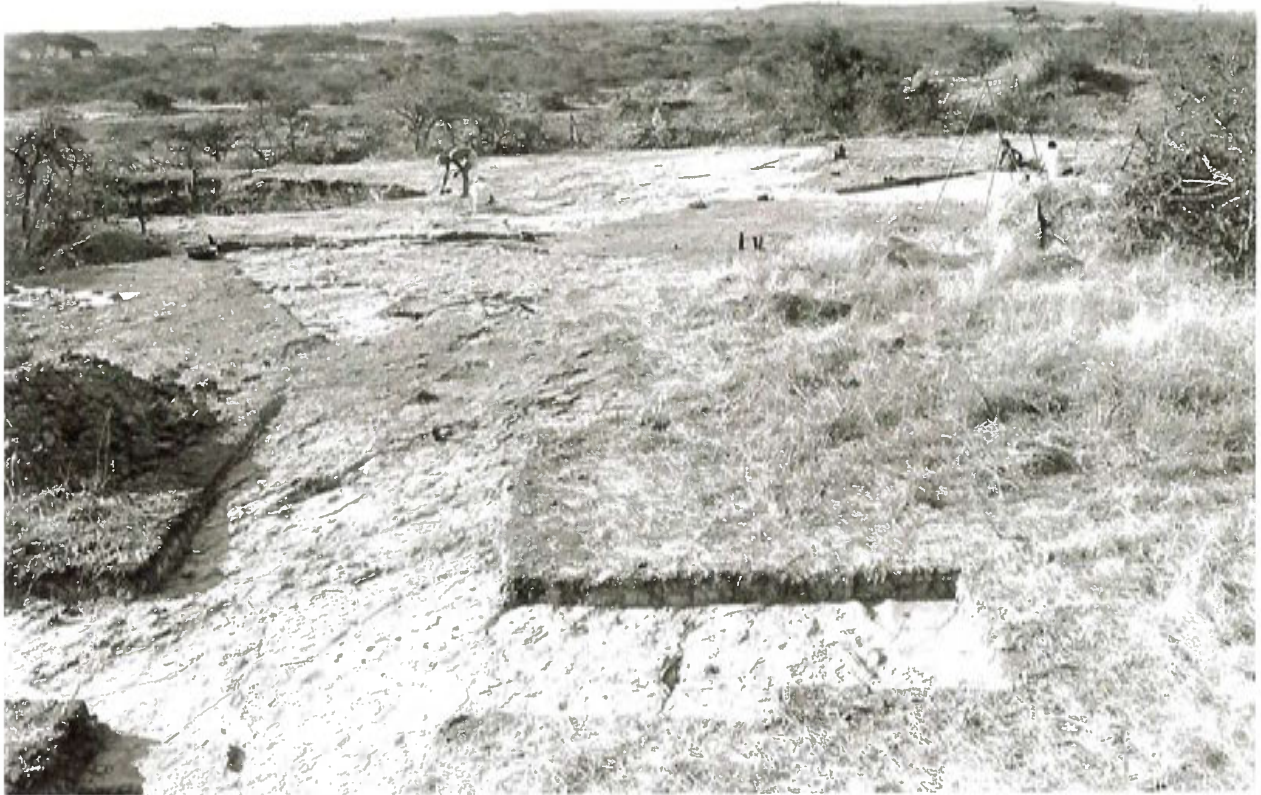

11. Excavation of the trackway in 1978. At lower right is the east extension of the trench excavated to find the continuation of the hominid trails to the south. Prints G1-25, 26, 27; G2/3-18, 19, 20 were revealed in the eastern extension trench. (Photograph by Tim White.)



12. The weathered tuff (right) and probable Lower Unit tuff below Horizon B (left) in the north half of the 1995 trench, from the west, after removal of acacia stumps and roots. 1979 cobble fill of west trench is visible in foreground.



13. Re-excavation of G2/3-18 revealed two puncture marks and absence of Bedacryl stain in the anterior portion of the print



14. Excavation of G1-26 and G2/3-27 with wooden tools (shaped tongue depressors) and small brushes. Polyester cast replicated from the 1979 cast (foreground) was used to guide the re-excavation.



15. G2/3-27 during re-excavation. Fill inside the print consisted of a range of particle sizes, from 1cm diameter pebbles to fine-grained sand. The raised edges along the perimeter of the print are fossilized termite burrows.



16. G1-26 with Bedacryl removed from the surface of Test Area A (lower center). As a result of the successful removal of the resin in the test area, Bedacryl was cleaned from the entire print and from G2/3-25 (see also Photo 17).

17. G2/3-17 with Bedacryl partially removed (below) (Note rootlets revealed beneath Bedacryl in heel). Bedacryl was then removed from the entire print (right). (see also Photo 18).



18. A section of the footprint trails showing dark Bedacryl stain in and around the footprints. Bedacryl was removed from G2/3-25, at upper right of photo, and from G1-26 (not shown).



21. Acacia stump #13 located near the eastern edge of the 1979 trench wall. Numerous lateral roots from the stump extended into trench wall, and two roots penetrated the tuff surface. This stump also marked the SE corner of the 1993 excavation trench.



22. Reattachment of disrupted tuff caused by the root penetration from stump #13.



19. Consolidation of tuff disrupted by a lateral root from stump #27, in preparation for its partial removal.



20. Acacia stump #21 at the border between the area of weathered tuff and the northern portion of the trackway. Note the abrupt transition between the weathered tuff and the Lower Unit tuff below Horizon B.



23. G2/3-21 pierced by a lateral root from acacia stump #83. Photograph taken in 1993.



24. G2/3-21 after the lateral root was cut. The root section visible on the right of the print was later fully extracted and the void infilled with Acrysol paste. The root on the left was reduced and milled.



25. Acacia stump #18, in the area of weathered tuff, being cut with a flexible fine-tooth handsaw.



26. A portion of acacia stump #18 being reduced by milling with a rotary mini-drill fitted with a micro-router bit.



27. The hominid footprints after conservation, beginning in the south (lower left) with prints G1-36 and G2/3-27 through G1-31 and G2/3-22 in the weathered tuff (upper right).

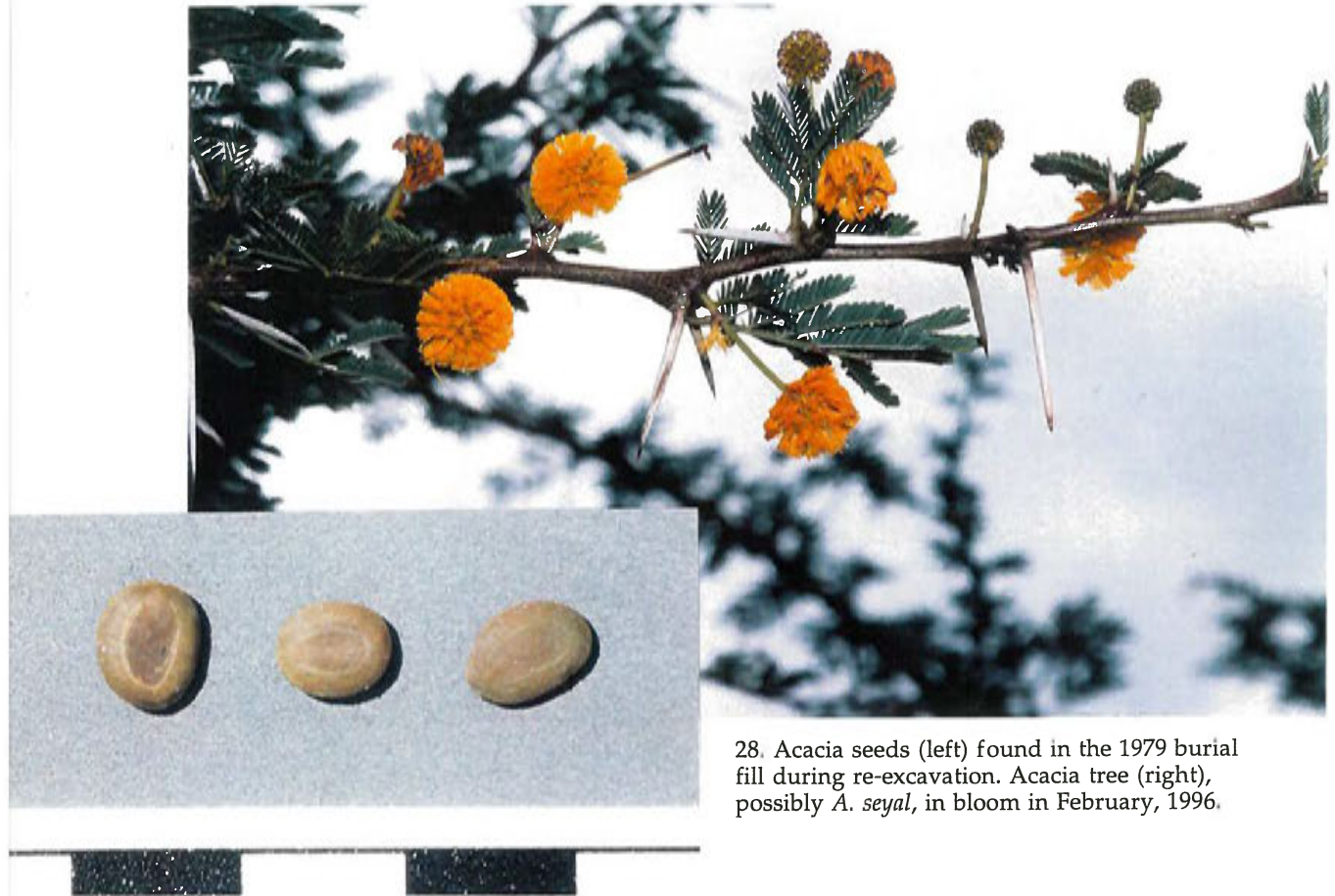

28. Acacia seeds (left) found in the 1979 burial fill during re-excavation. Acacia tree (right), possibly *A. seyal*, in bloom in February, 1996.

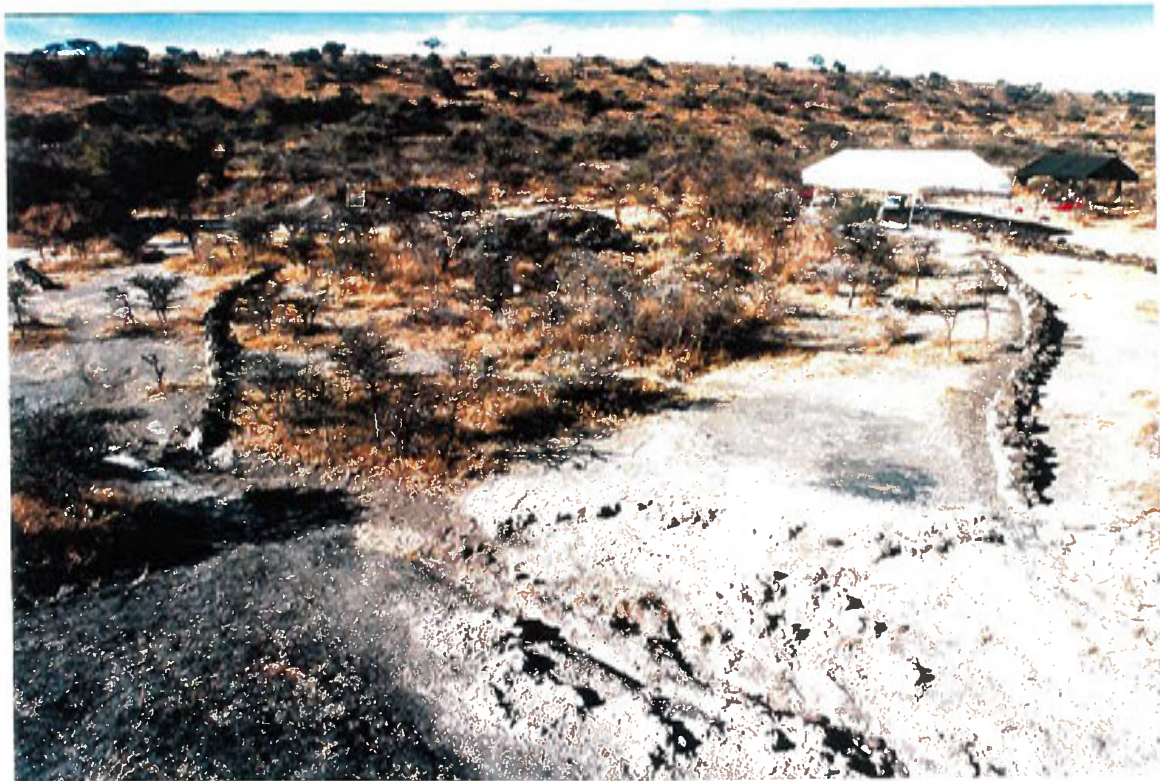

29. Berm 2 (left, center) and newly constructed Berm 3 (right, center). At lower center is the debouchment of Drainage Channel 2.

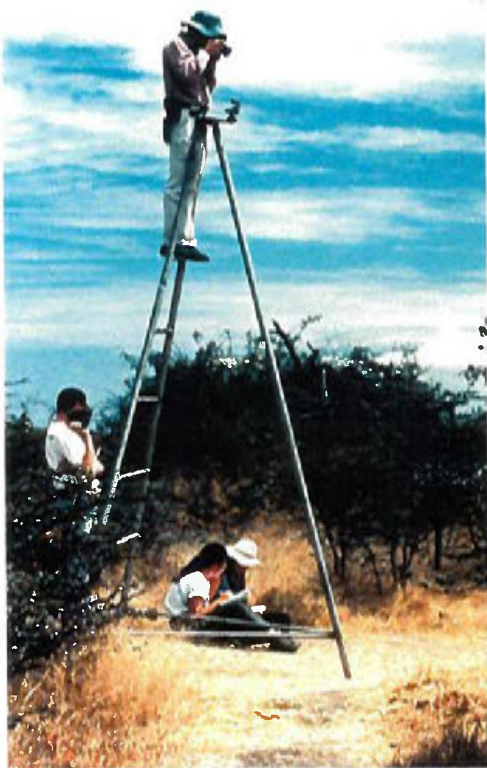

30. The 12' tripod for photography (above) and 8x10 Polaroid camera (right).

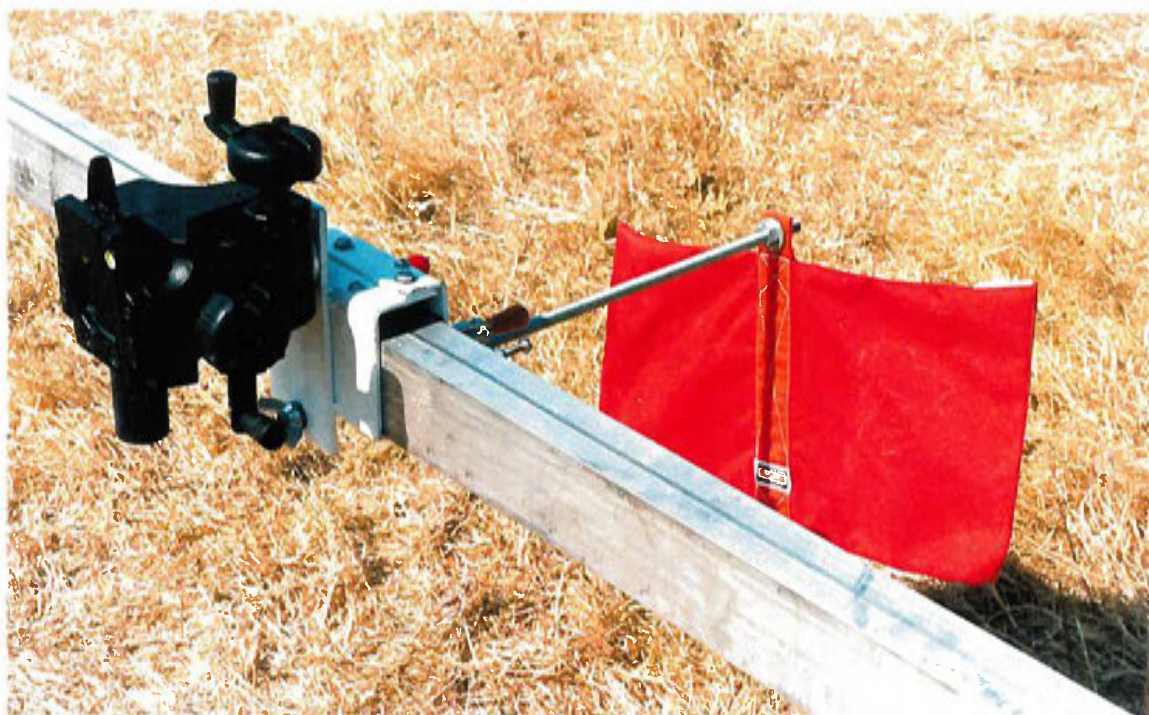

31. The crossbar and camera bracket with sandbag counterweight.



32. Jesuit Temba applying base color to the Section A cast being prepared for exhibition in Dar es Salaam.



33. Reburial: applying the first layer of sand to hominid impressions.





34. Early stage of the reburial showing Layer 1 in place, placement of geotextile above Layer 1 with small mounds of Layer 2 to hold it in place, and geodrain in the 1979 west trench.



35. Middle stages of the reburial showing upturned edges of 1st layer of Biobarrier partially covered by Layer 3. Layer 3 is in progress: the center of the mound is being established along tape line and geotextile over the 1979 land surface in foreground is not yet covered.



36. Test Site 3. Placement of duplicate test samples in the north (top) and south (bottom) sections of the reburial monitoring trench.



37. Test Site 3. Partial reburial of monitoring trench showing vertical placement of Biobarrier on trench walls, Layer 2 and separator barrier between north and south sections of the trench.

FIGURES

LAETOLI SITE G 1995

Plan of southern trackway
 showing relative positions of
 1979, 1993, and 1995 excavation trenches.

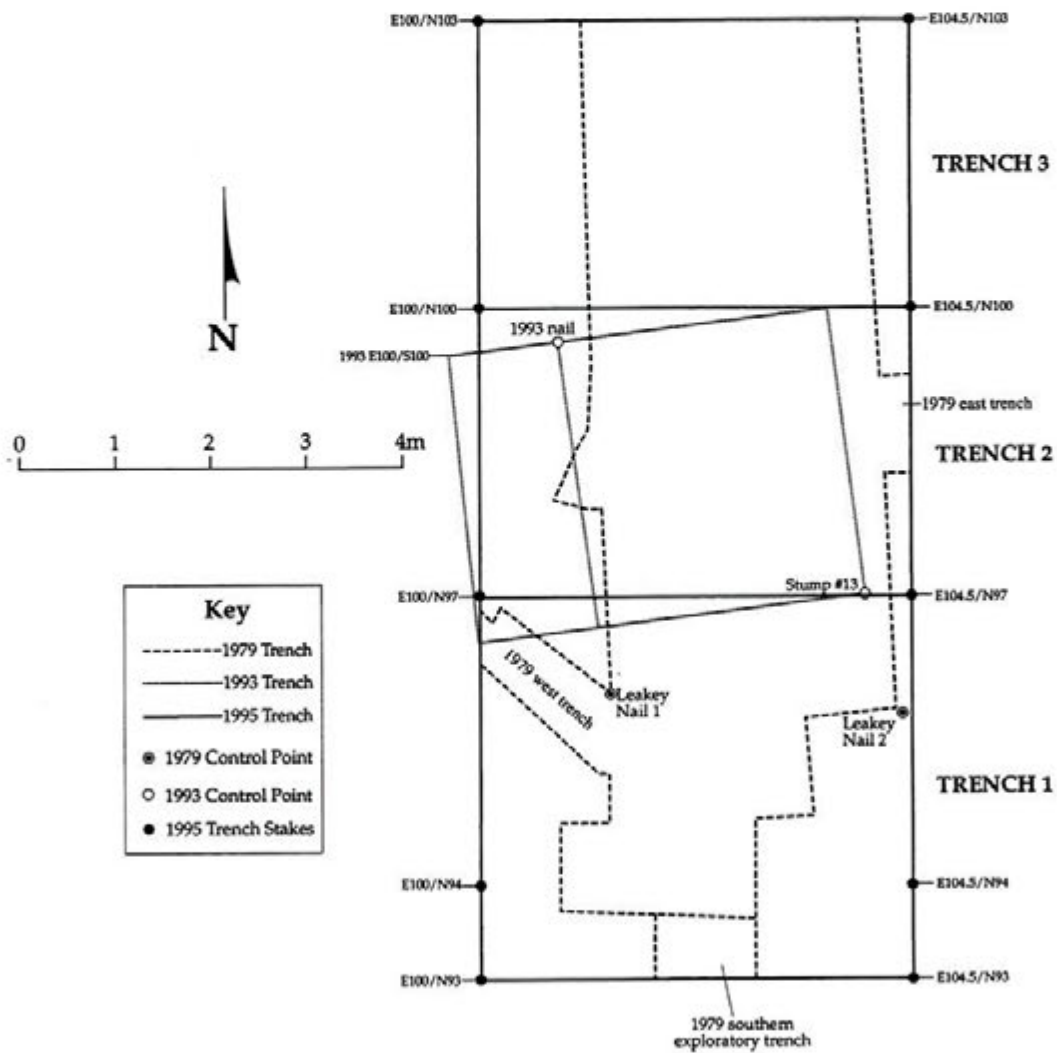

LAETOLI SITE G 1995
 Plan of southern trackway showing
 relative positions of 1979 and
 1995 excavation trenches
 and section lines (A-A', B-B', C-C', D-D').

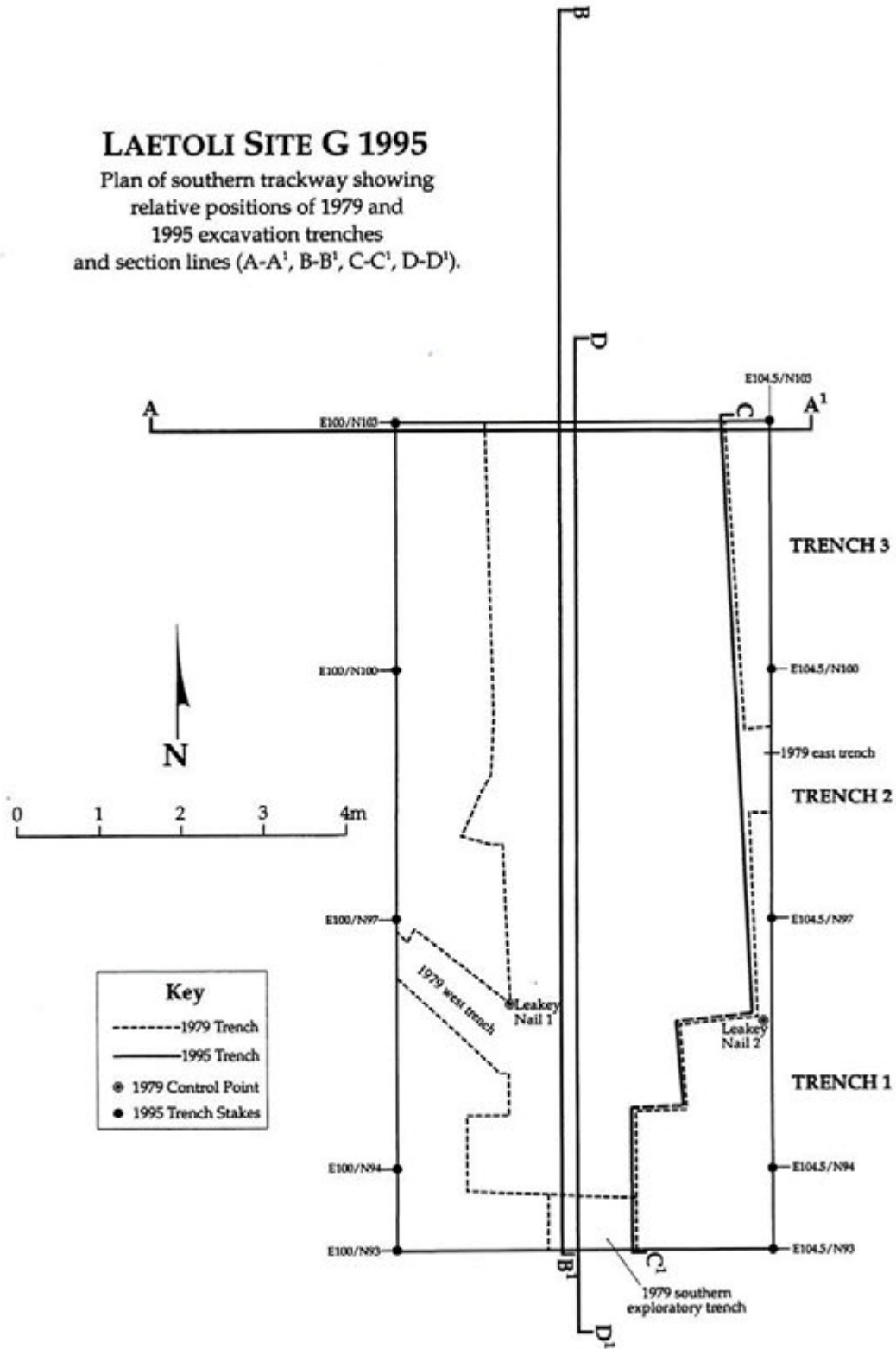
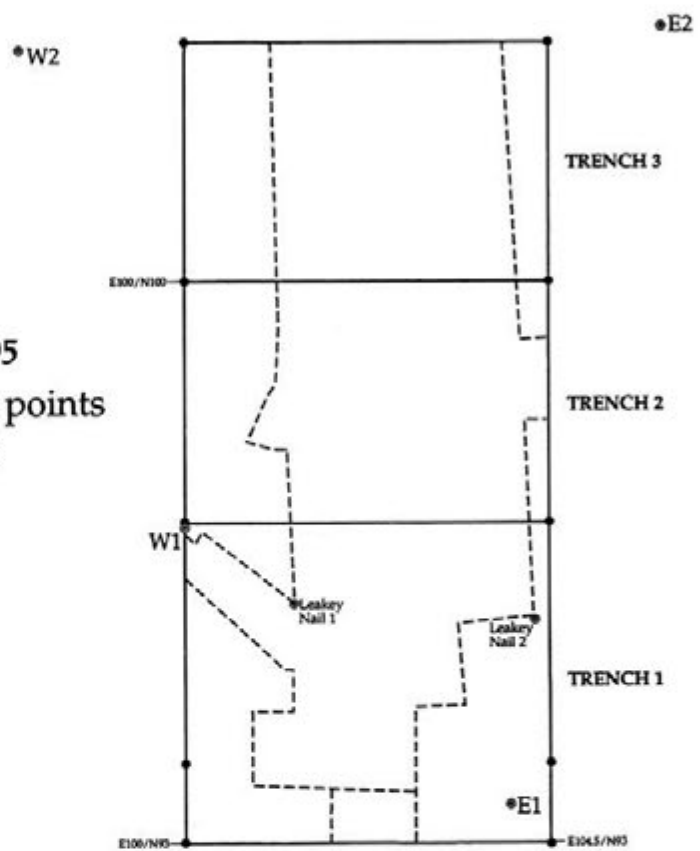

FIG. 4

LAETOLI SITE G 1995
Locations of major datum points
(E1, E2, W1, W2, S)



S*

0 1 2 3 4m

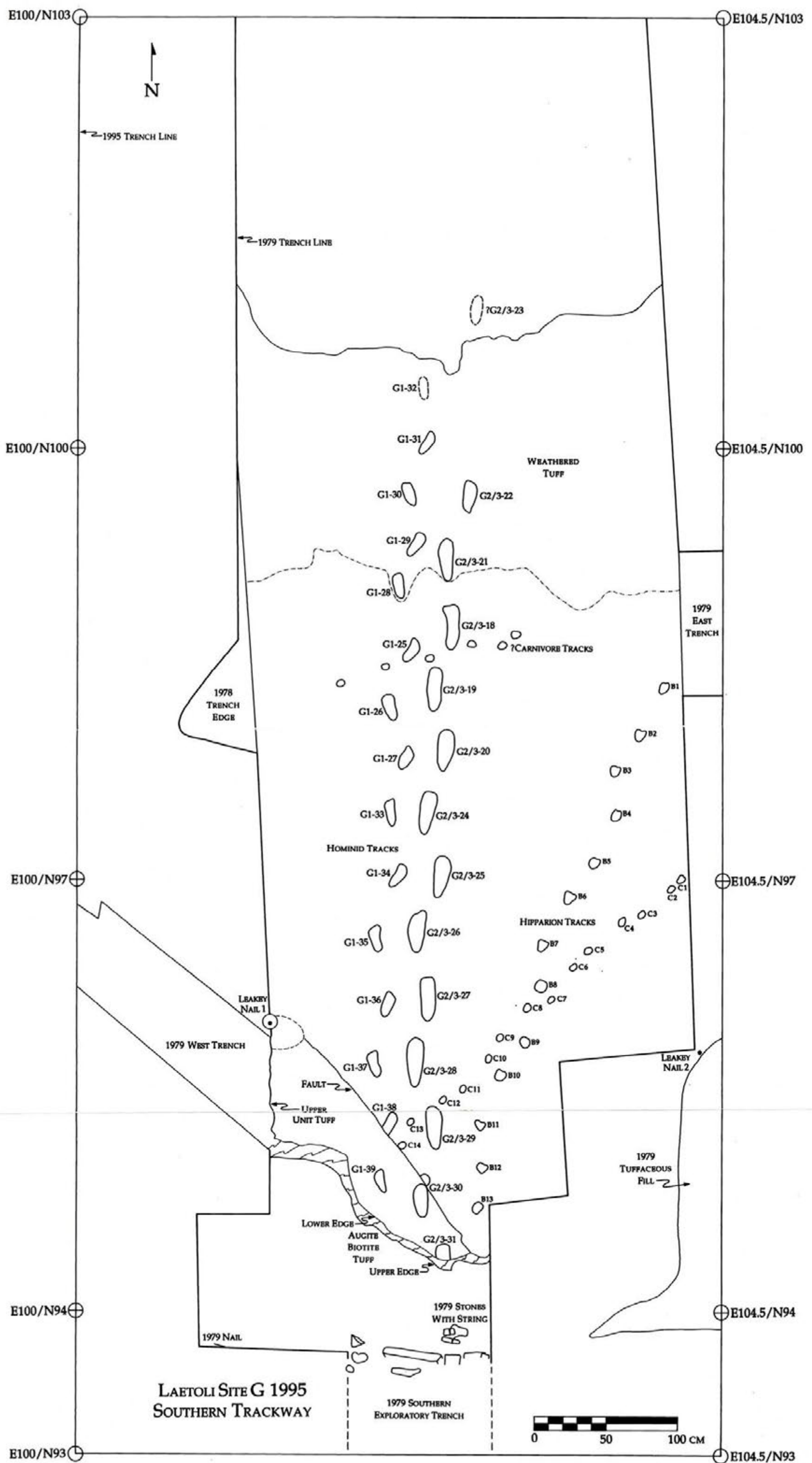

FIG. 5

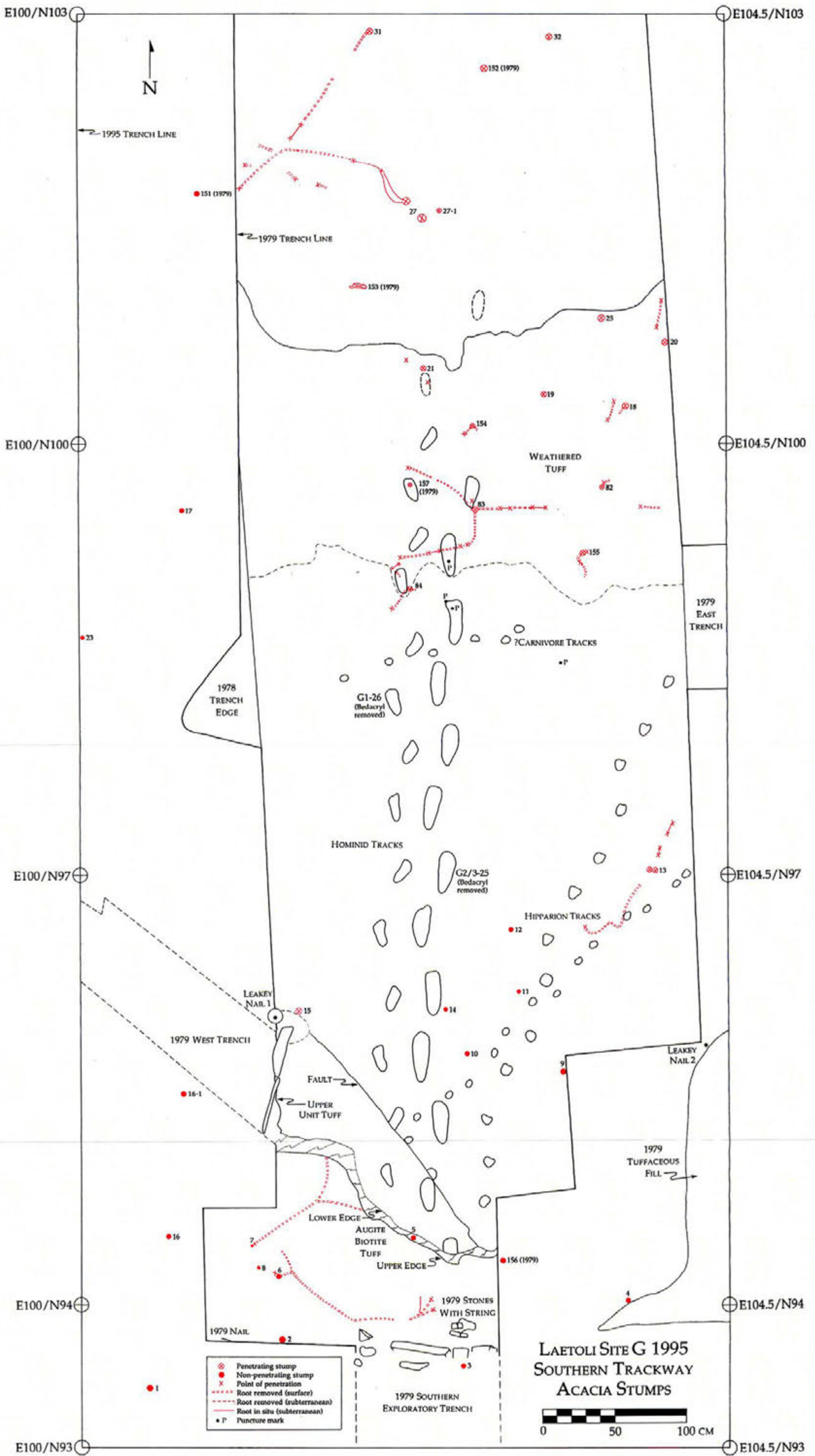

FIG. 6

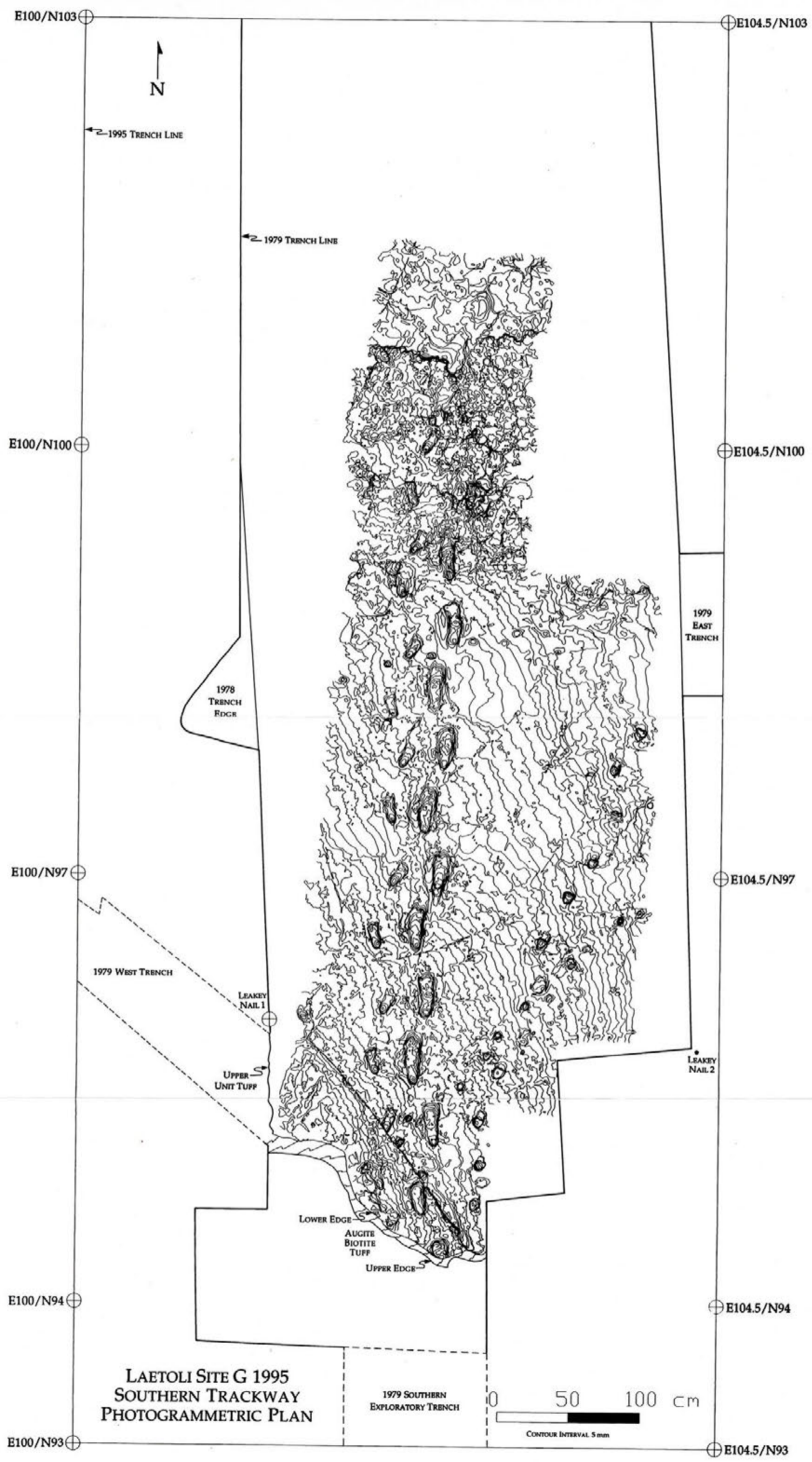
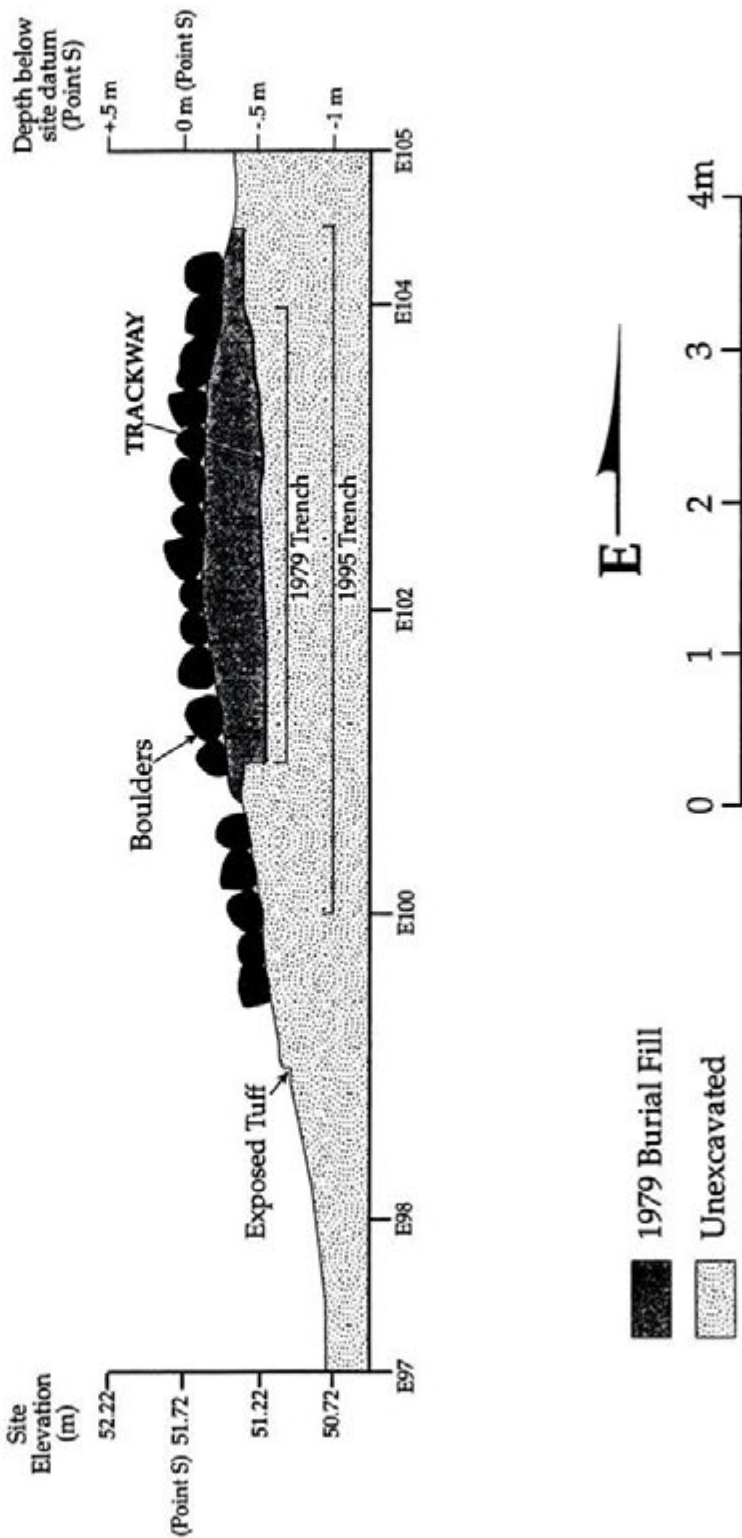

FIG. 7

LAETOLI SITE G 1995 Section A-A¹

E-W section of north wall of the 1995 trench showing the 1979 burial mound and the trackway surface.



LAETOLI SITE G 1995 Section B-B'

N-S section showing 1979 burial mound,
1995 disturbance, and re-excavated trackway surface

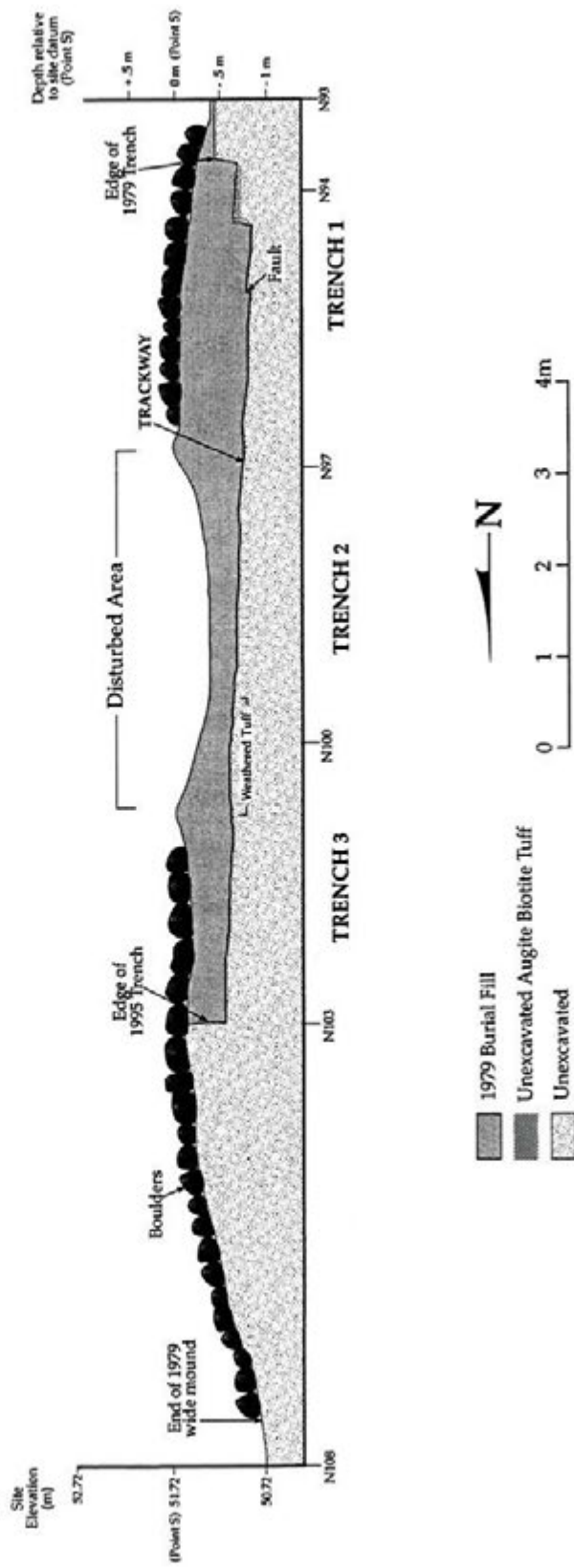

FIG. 9

LAETOLI SITE G 1995 Section C-C¹

N-S section showing the 1995 and
1979 east trench walls

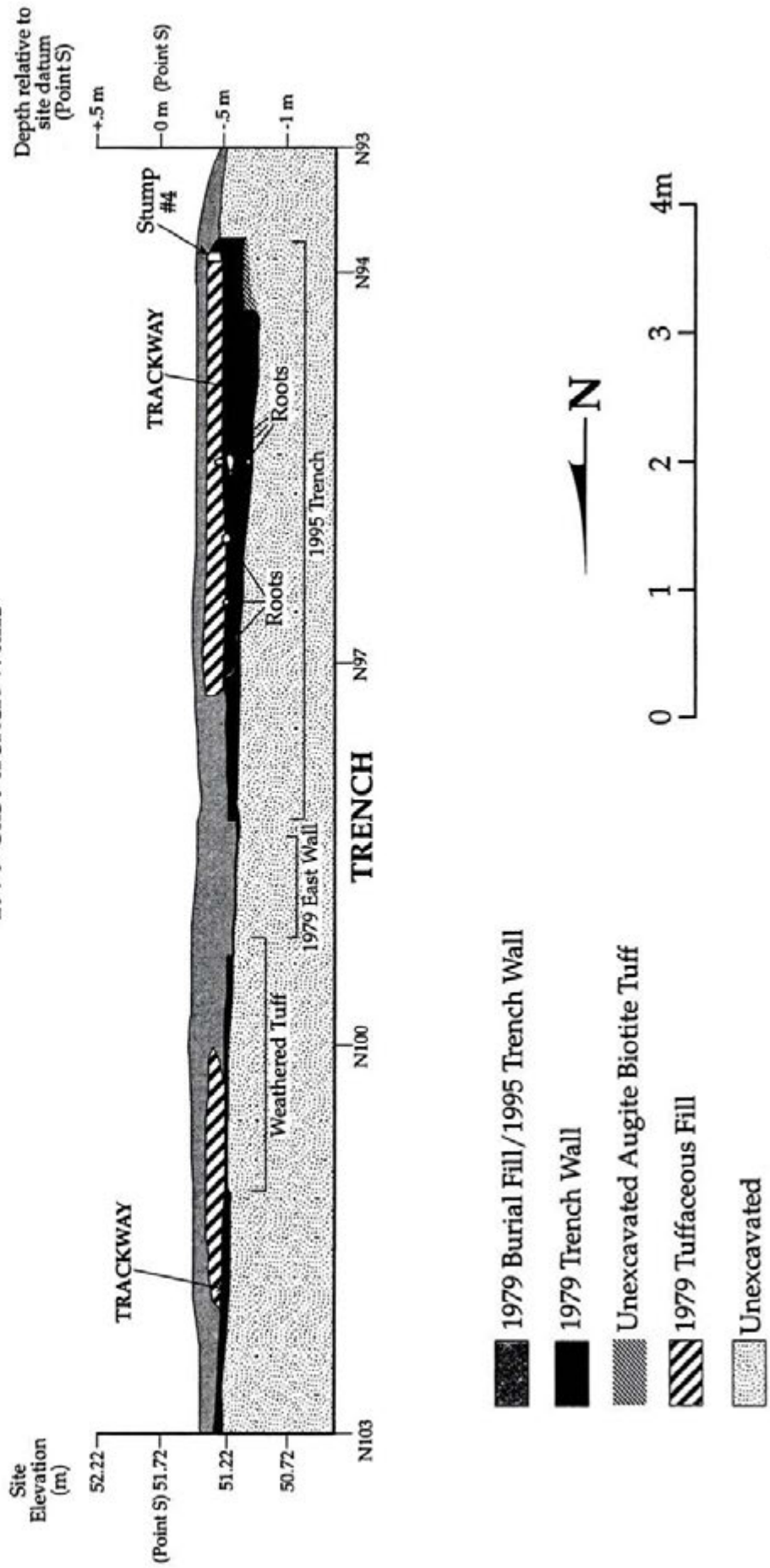

FIG. 10

LAETOLI SITE G 1995 Section D-D¹

N-S section of 1995 Reburial

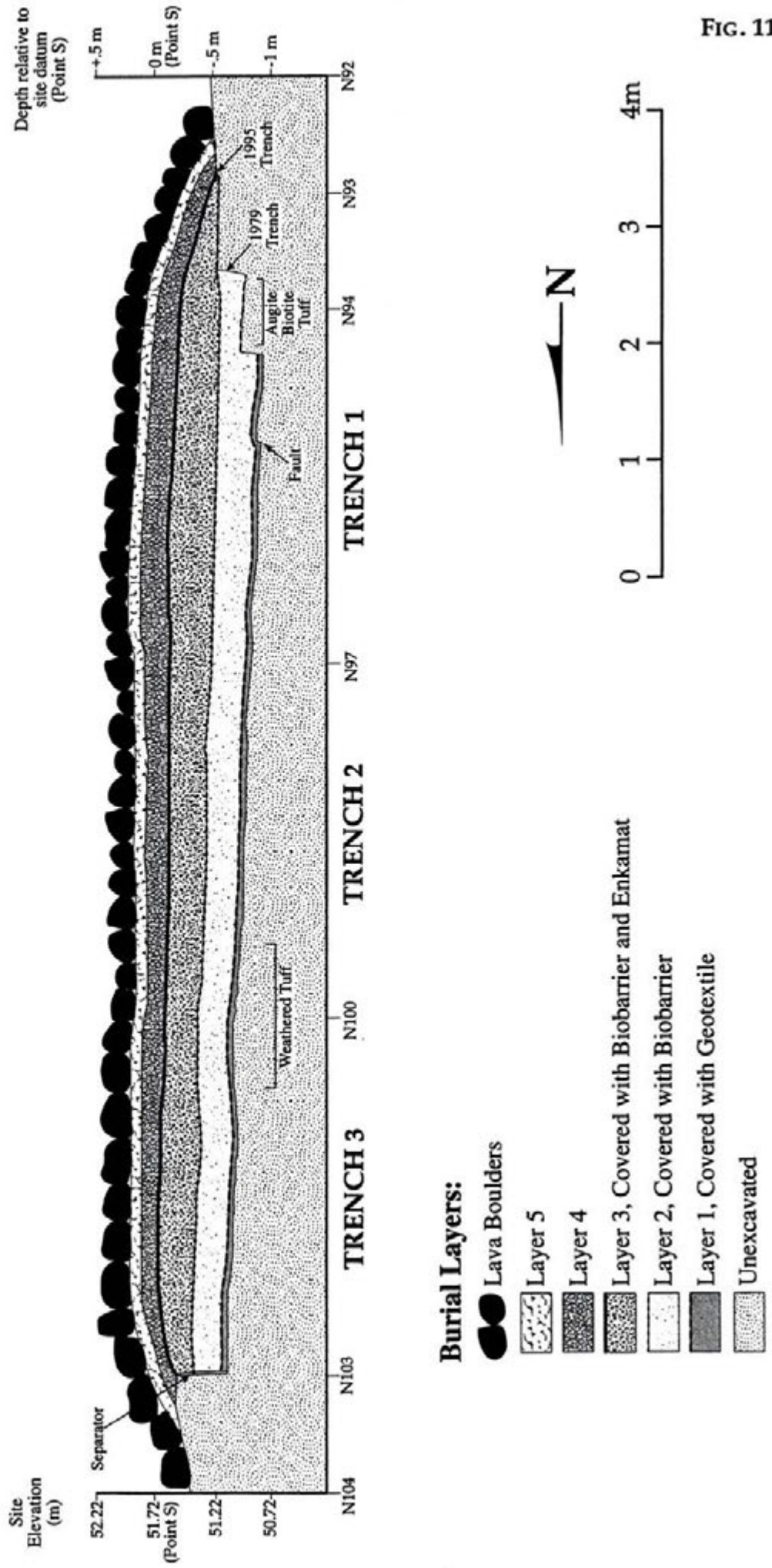

FIG. 11

HOMINID FOOTPRINTS

G-1 Trail			G-2/3 Trail		
Left	Indeterminate	Right	Left	Indeterminate	Right
1			1		2
		2			
3			3		4
		4			
	5?		5		6
	6				
	7		7		8
	8				
9			9		10
		10			
11			11		
		12			12
13					13
		14			14
15					15
	16				16
	17		17		
	18			23	
19					22
		20?	21		18
21					
		22	19		20
23					24
		24	24		25
32					26
		31	26		27
30					
		29	28		29
28					30
		25	30		31
26					
		27			
33					
		34			
35					
		36			
37					



Site G
Sequence of footprints in
Trails G-1 and G-2/3

FIG. 13.1. Schematic plan to show location of numbered footprints in hominid trails G-1 and G-2/3. Note that the numerical sequence of numbers allocated to the prints is in order of their discovery and excavation.

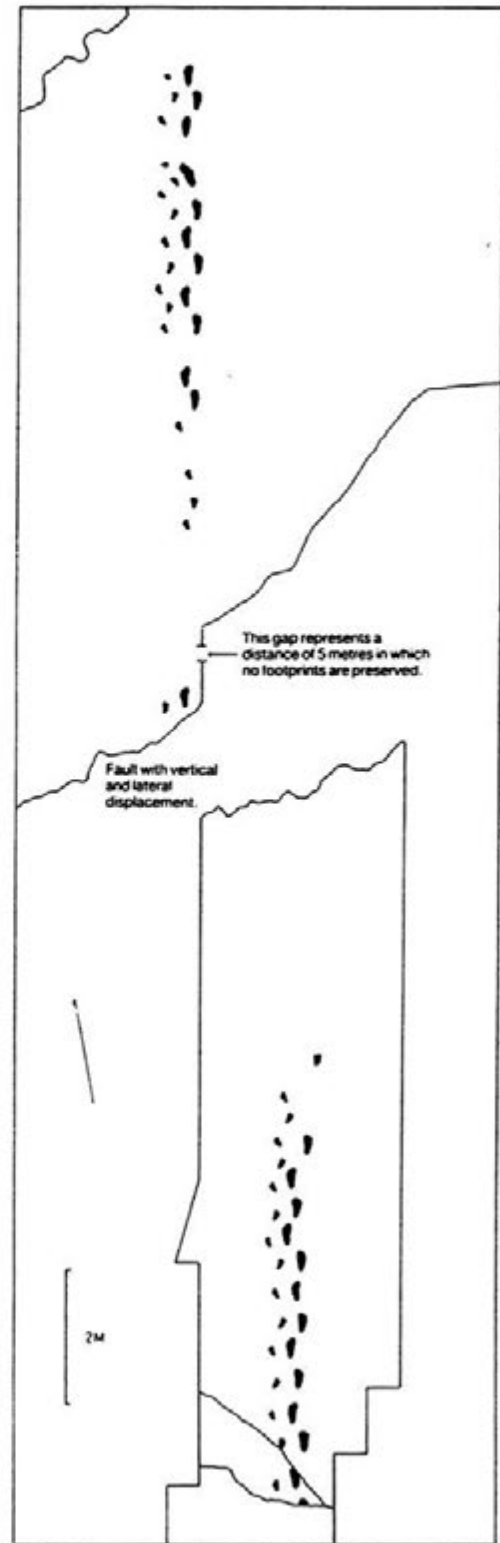
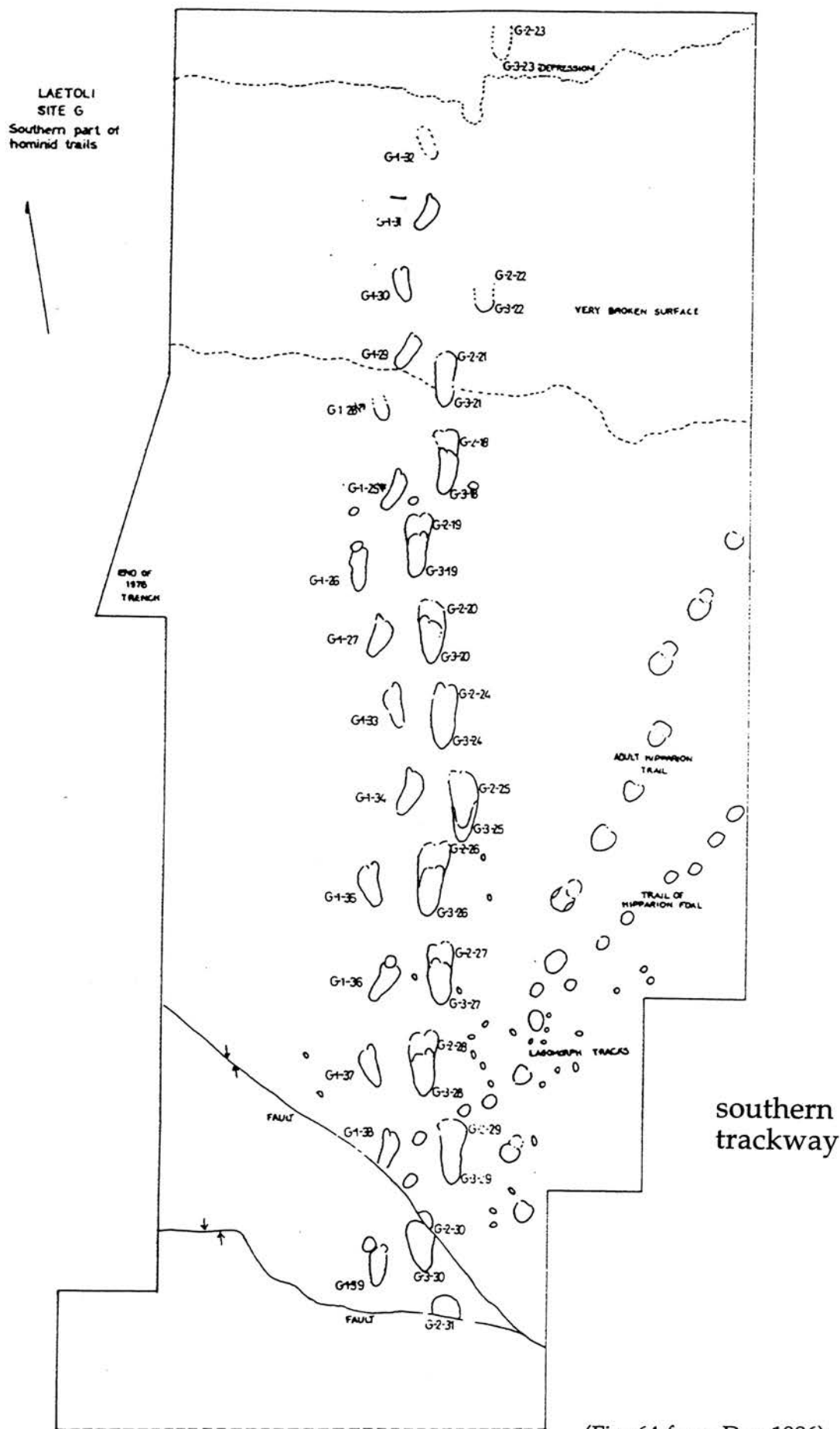

FIG. 13.2. Diagrammatic representation of the hominid trails at Site G.



(Fig. 64 from Day 1986)

FIG. 14

